

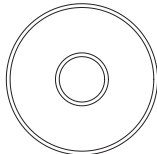
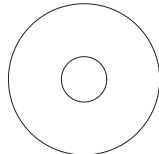
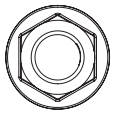
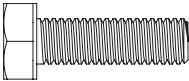
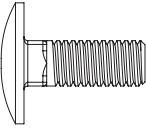

**IN8110**

**ULTI Bars - X2**

<p><b>FX4013 X4</b> (M6)</p> 	<p><b>FX4014 X4</b> (RUBBER)</p> 	<p><b>FX4016 X12</b> (M6)</p> 	<p><b>FX4026 X4</b> (M6X20)</p> 	<p><b>FX4042 X8</b> (M6X16)</p> 	<p><b>MA6018 X4</b></p> 	<p><b>MA6065 X4</b></p> 	<p><b>ME0203 X4</b></p> 
<p><b>ME0776 X2</b></p> 	<p><b>ME0777 X2</b></p> 	<p><b>AS3190 X2</b></p> 					

**TOOLS REQUIRED**

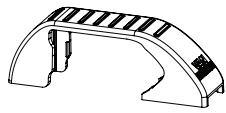
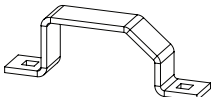
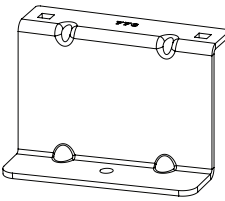
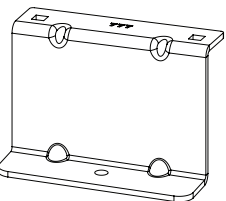
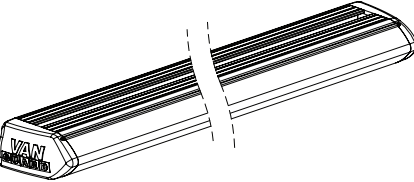
10MM X 1

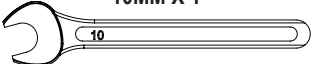

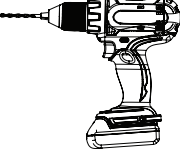

DRILL (Ø4 & Ø6) X 1



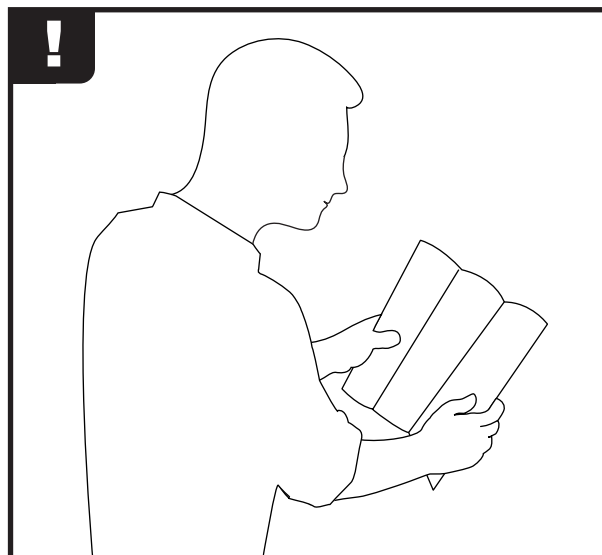

10MM X 1  
(LONG HANDELED SOCKET)





 **GB.** Maximum load per roof bar = 55kg. Maximum load is in accordance with the vehicle manufacturer's load bearing capacity (refer to the vehicle handbook). **Do not exceed this limit.**

 **FR.** Poids maximum par barre de toit = 55kg. La charge maximale doit être conforme à la capacité de charge du constructeur de véhicule (veuillez- vous référer au livret du véhicule). **Ne dépassez pas cette limite.**

 **DE.** Maximallast pro Dachträger = 55kg. Die Maximallast steht im Einklang mit der angegebenen Ladekapazität des Fahrzeugherstellers (diese finden Sie im Fahrzeughandbuch). **Die Maximallast darf nicht überschritten werden.**

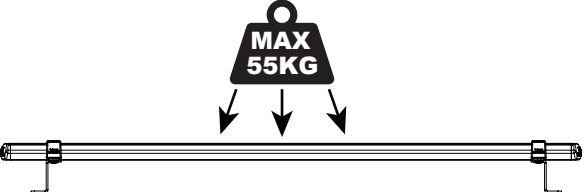
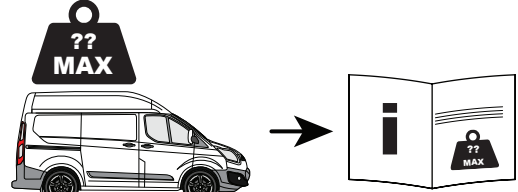
 **DK.** Maksimum last pr tagbøjle = 55kg. Maksimal lasteevne afhænger af varevognproducents angivelser i varevognens håndbog. **Overskrid ikke denne grænse.**





This FITTING INSTRUCTION is the property of VAN GUARD ACCESSORIES LTD. and must not be used for manufacturing purposes, copied nor communicated in any way to third parties without written permission from VAN GUARD ACCESSORIES LTD.  
IN8110\_B - IW - 09/01/2017

Van Guard Accessories Ltd  
Fair Oak Close, Exeter Airport Business Park,  
Exeter, Devon, EX5 2UL  
www.van-guard.co.uk

## VG308-2

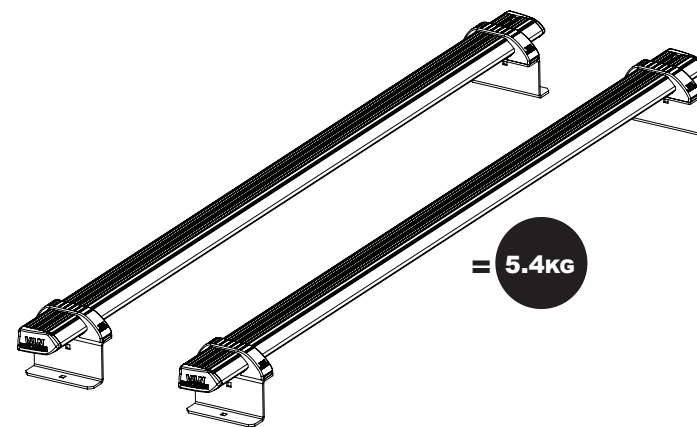
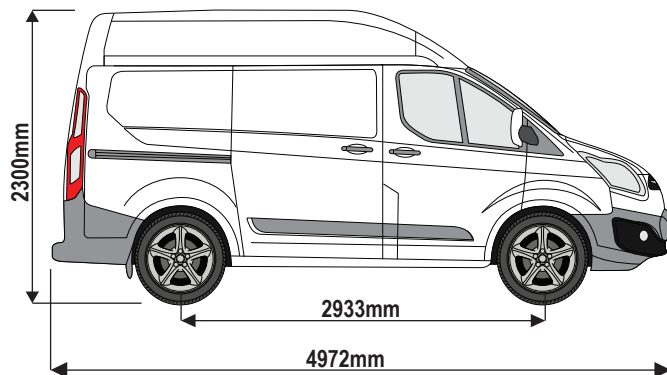
**Vehicle:**  
Ford Transit Custom: 2012 on  
**Wheel Base:** SWB (L1)  
**Roof Height:** High (H2)  
**Rear Doors:** Twin



## VG308-2

**Vehicle:**  
Ford Transit Custom: 2012 on  
**Wheel Base:** LWB (L2)  
**Roof Height:** High (H2)  
**Rear Doors:** Twin

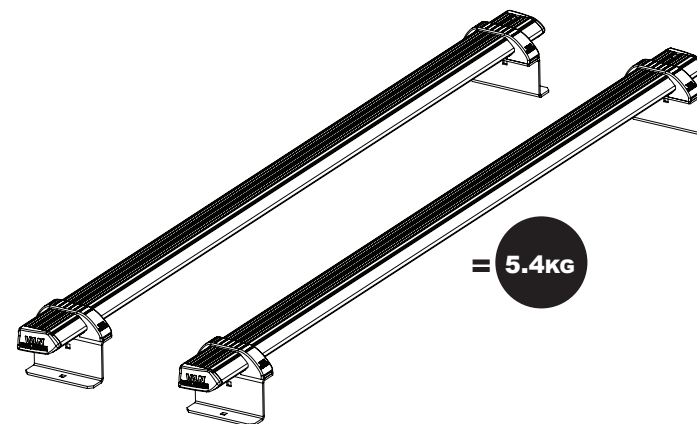
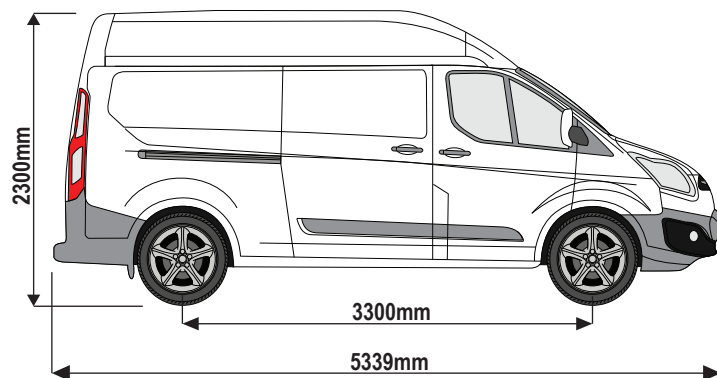

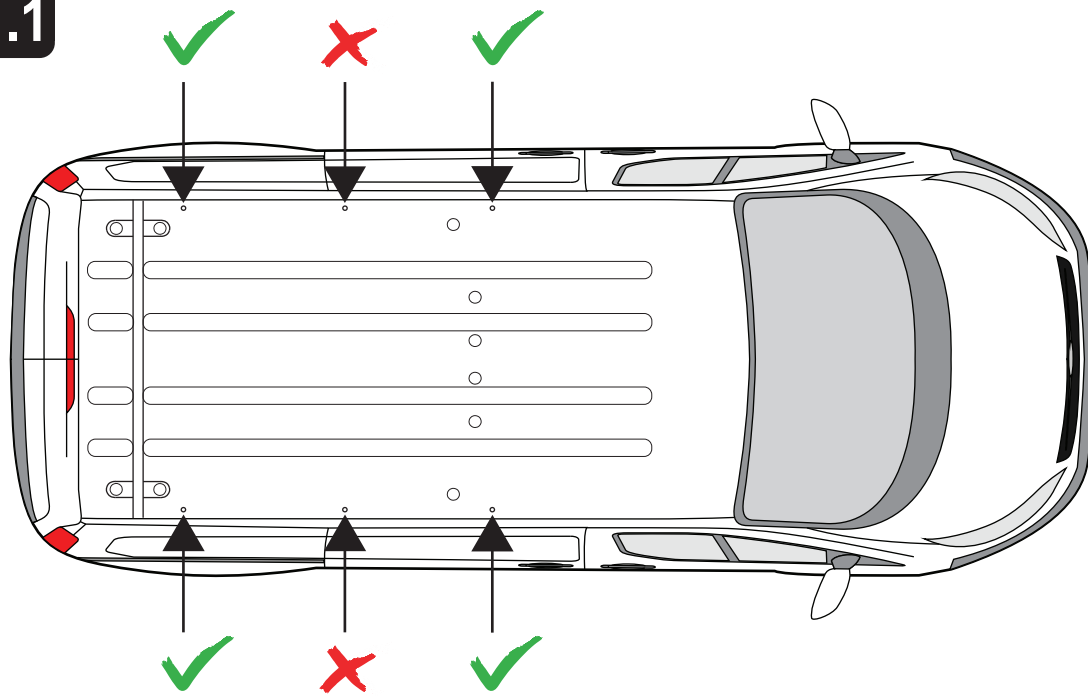
**1.1****GB**

As there are no fixing points on the vehicle it's necessary to drill the roof. The vehicles roof has 6 x dimples (3 per side), use these as positions to drill the fixing points. Please note, the roof plugs / gromits are not used to fit this product. **If your vehicle does not have these dimples please refer to IN8200.**

**FR**

Comme il n'y a pas de points de fixation sur le véhicule, il est nécessaire de forer le toit. Les véhicules Toit a 6 x fossettes (3 par côté), utilisez-les comme des positions pour forer les points de fixation. S'il vous plaît Notez que les bouchons de toit / gromits ne sont pas utilisés pour adapter ce produit. **Si votre véhicule ne Avoir ces fossettes s'il vous plaît se référer à IN8200.**

**DE**

Da keine es keine Befestigungspunkte am Fahrzeug gibt, ist es notwendig, eine Bohrung durch das Dach durchzuführen. Das Dach des Fahrzeuges hat 6 x Vertiefungen (3 pro Seite), verwenden Sie diese Positionen, um die Befestigungspunkte zu bohren. Bitte beachten Sie, dass die Dachstecker/Vertiefungen nicht verwendet werden, um das Produkt anzubringen. **Wenn Ihr Fahrzeug diese Vertiefungen nicht besitzt, folgen Sie bitte IN8200.**

**DK**

Da der ikke er originale fastgørelsespunkter på køretøjet, er det nødvendigt at bore i taget. Køretøjets tag har 6 markeringer (3 på hver side) - brug disse som borepunkter. **Hvis dit køretøj ikke har disse markeringer, henviser vi til IN8200.** Vær opmærksom på at tagets plastikpropper ikke markerer boringsposition og ikke skal bruges til at fastgøre dette produkt.

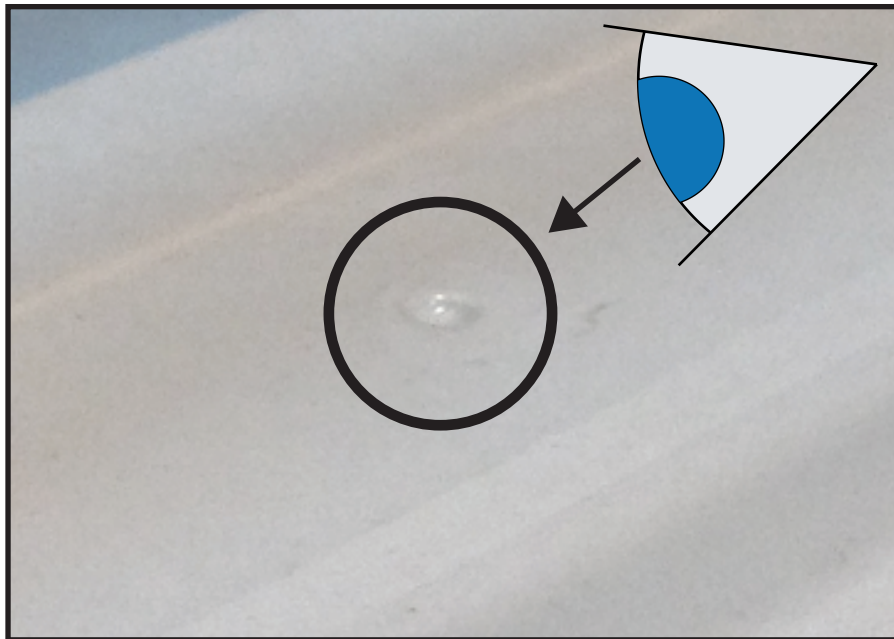
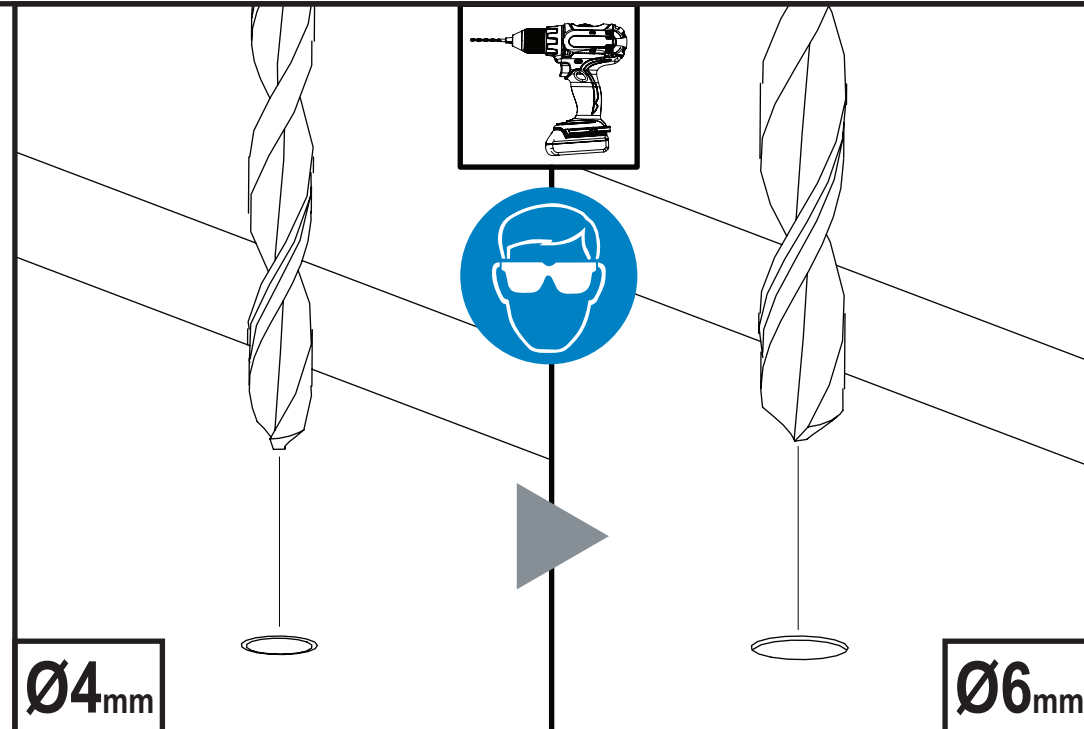
**1.2****Ø4mm****Ø6mm**

2

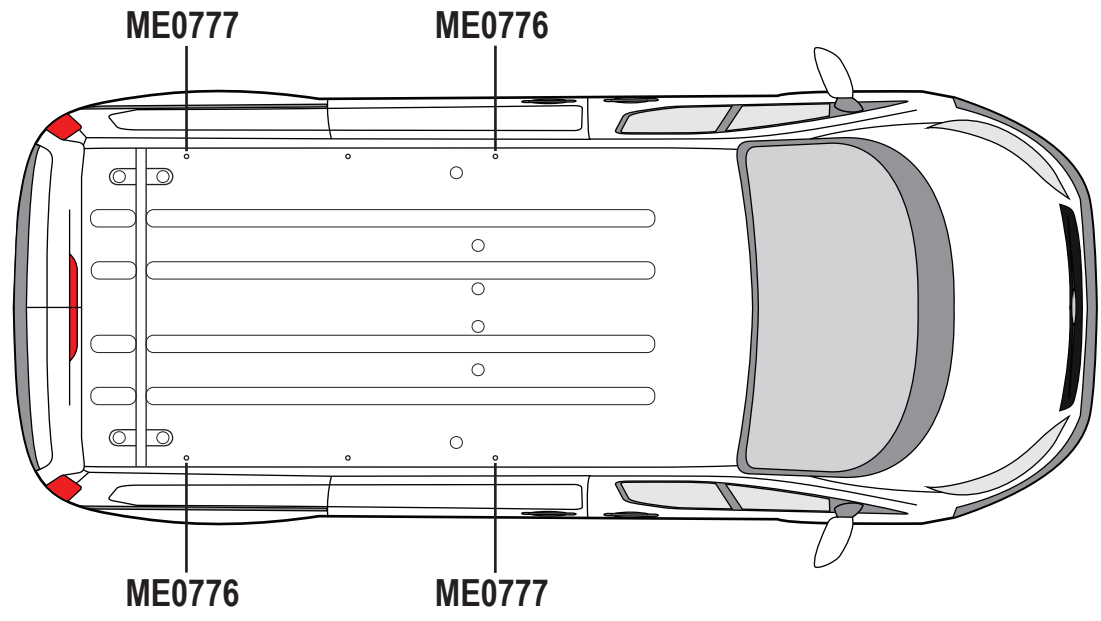

ME0776

ME0777

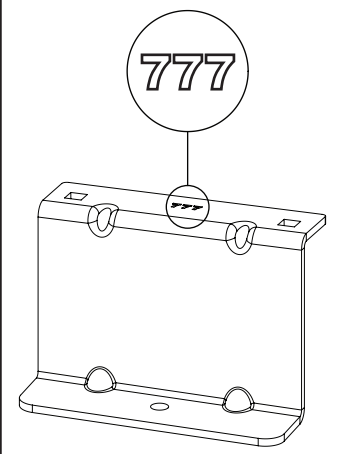
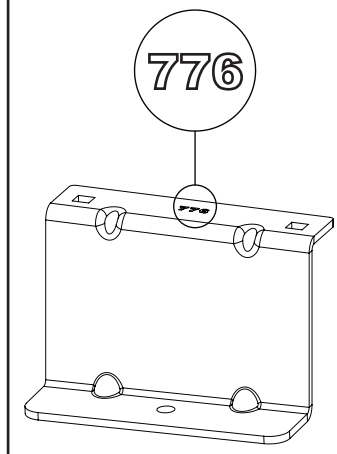

3

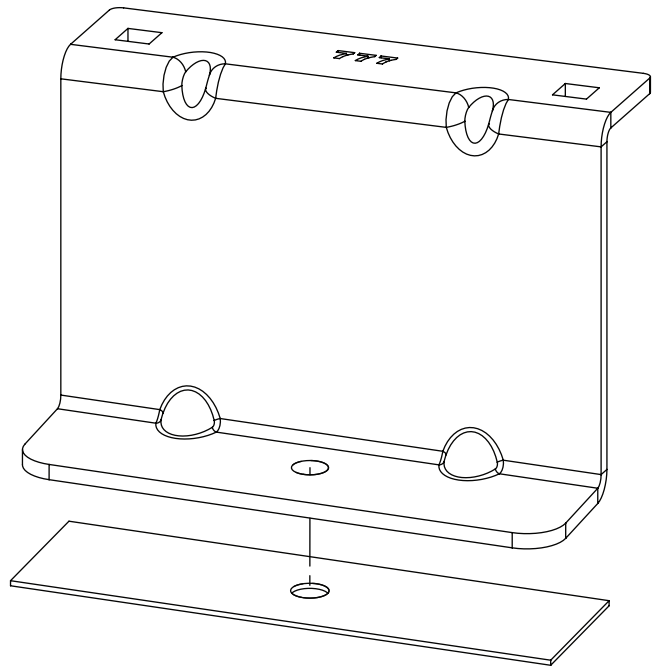

4.1

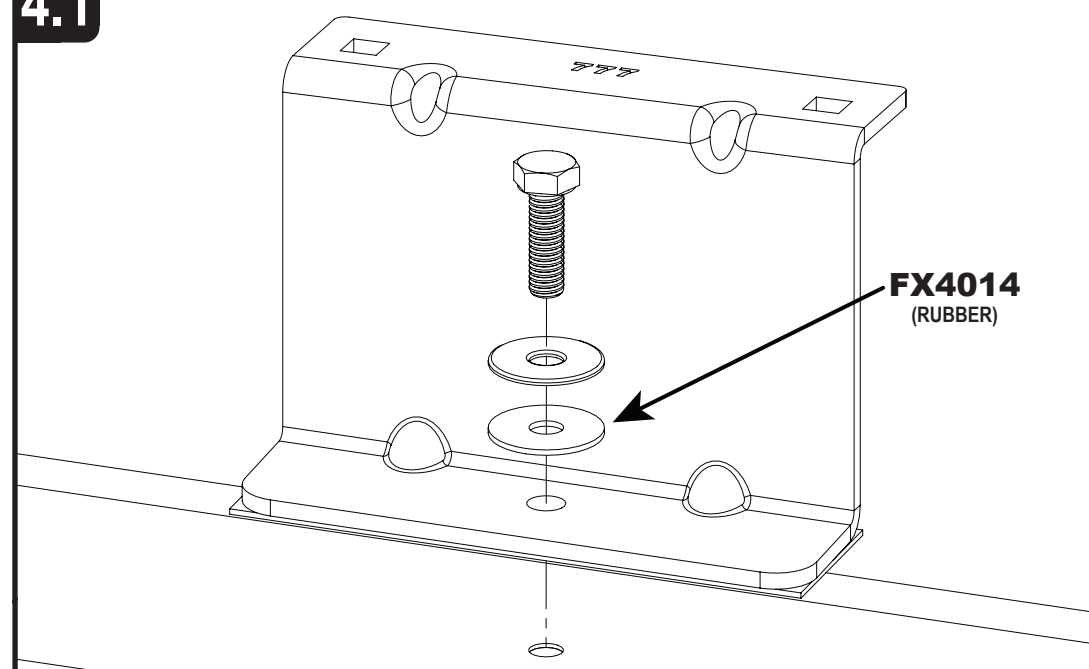

4.2

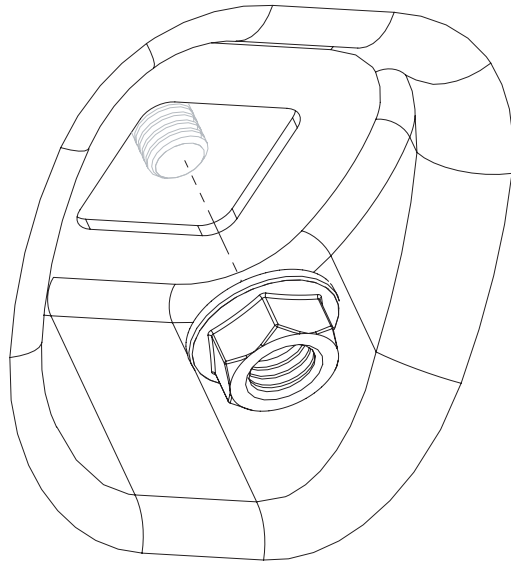

8Nm

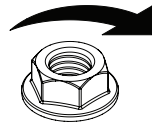

Use a long handled socket to reach the M6 flange nut.

GB



Utiliser une prise à long manche pour atteindre l'écrou de bride M6.

FR



Brug en lang håndteres sokkel at nå M6 flange møtrik.

DE



Verwenden Sie eine langgestreckte Steckdose, um die M6-Flanschmutter zu erreichen.

DK

5

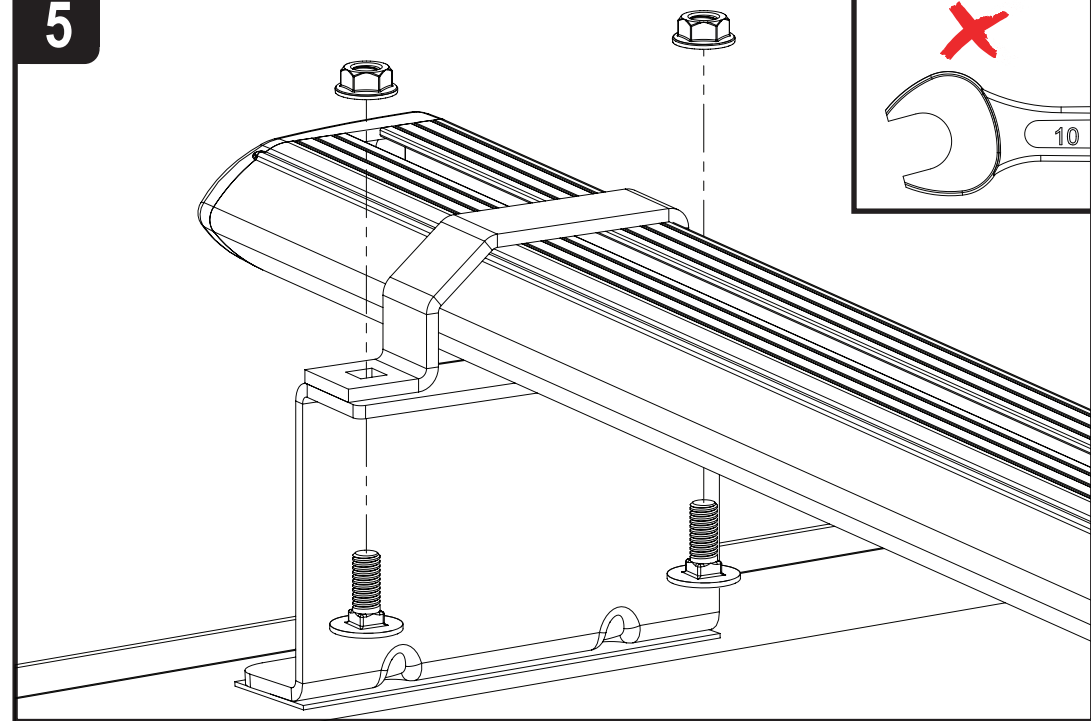

6

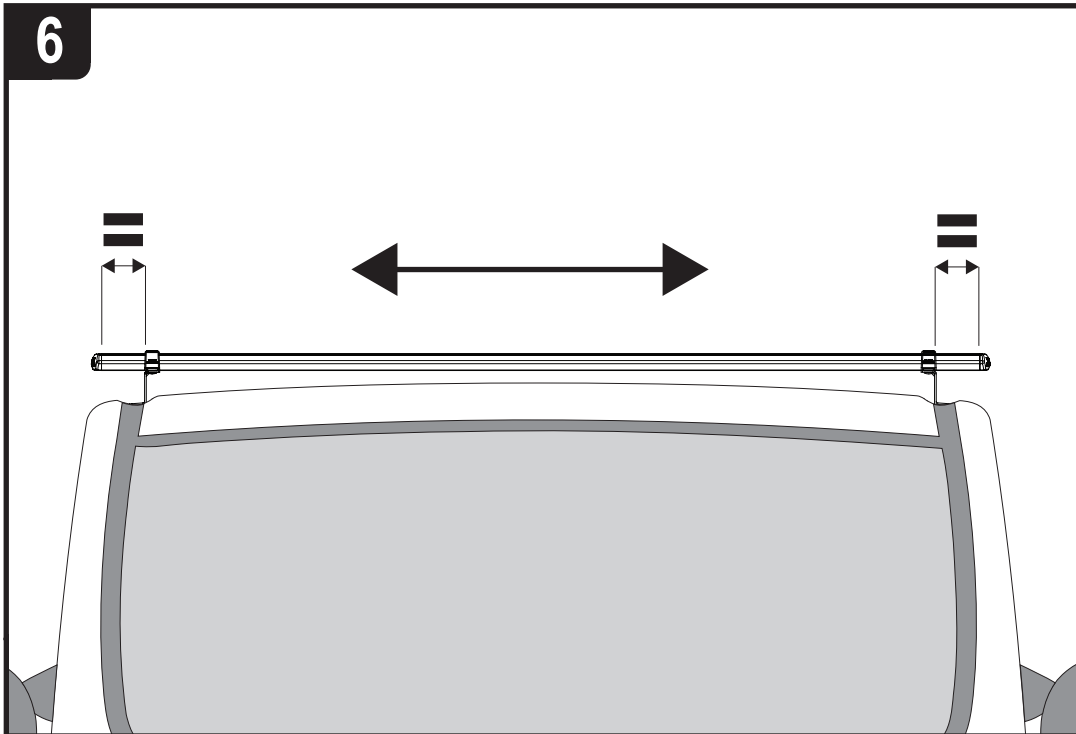

7

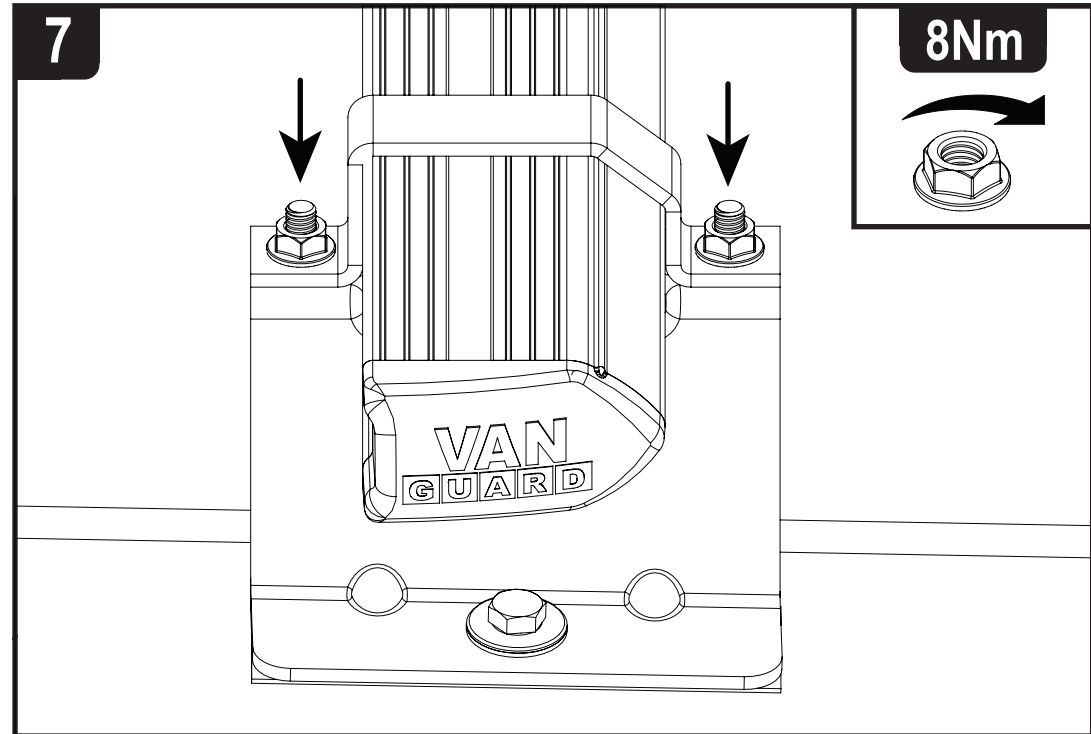

8Nm



1.

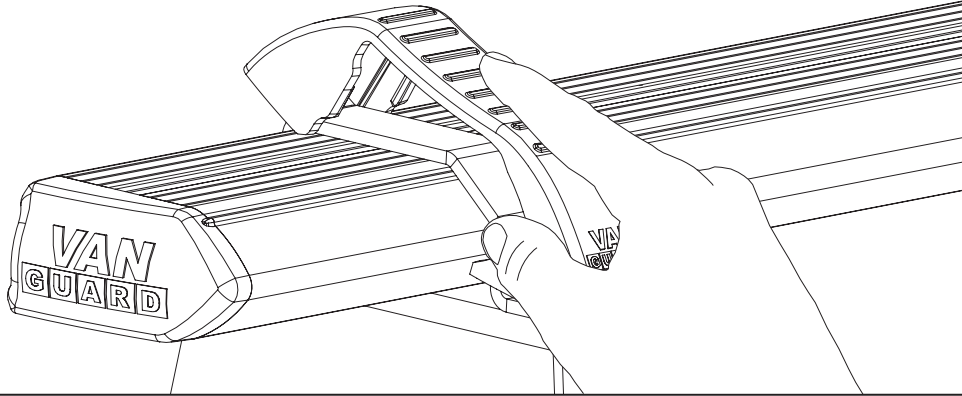

2.

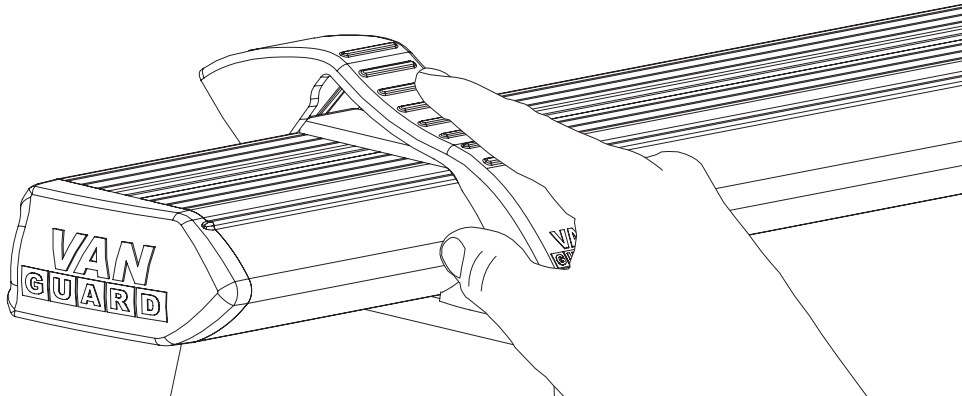

3.

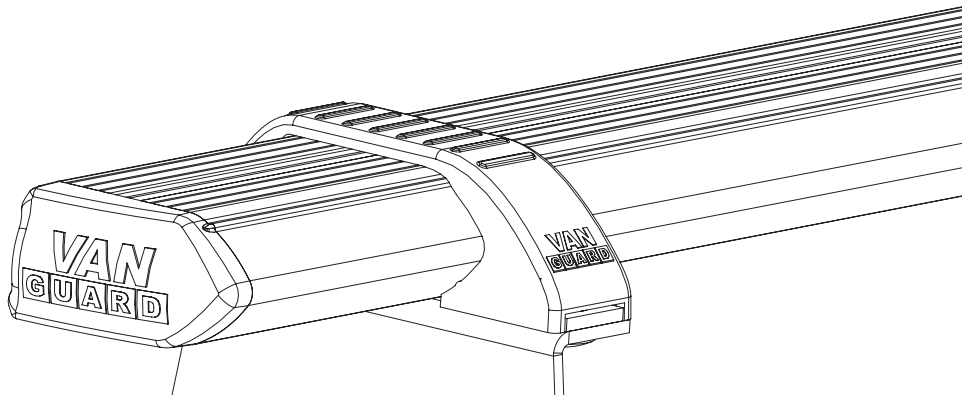

**GB**

1. Regularly inspect all fixings and parts. Any damaged or worn parts should be immediately removed from the vehicle and replaced.
2. Take care when loading and unloading goods on to and off the vehicles roof.
3. Van Guard Accessories LTD and/ or its distributors do not accept liability for:
  - Any products that have been fitted incorrectly.
  - Any products which have been fitted to the incorrect vehicle.
  - Any products that have been modified in any way or are being used for any purpose that they are unintended for.
4. It is important that the end user receives this document and that instructions are retained for future use.



**FR**

1. Inspecter régulièrement toutes les fixations et les pièces. Les pièces endommagées ou usées doivent être immédiatement retiré du véhicule et remplacé.
2. Prendre garde lors du chargement et du déchargement de marchandises vers et hors des véhicules toit.
3. Van Guard Accessoires Ltd et/ ou ses distributeurs n'accepte pas de responsabilité pour:
  - Les produits qui ont été ajustés de manière incorrecte.
  - Les produits qui ont été montés sur le véhicule incorrect.
  - Les produits qui ont été modifiés de quelque façon ou sont utilisés à toutes fins qu'ils sont involontaires.
4. Il est important que l'utilisateur final reçoit ce document et que les instructions soient conservés pour une utilisation futur.



**DE**

1. Prüfen Sie regelmäßig alle Befestigungen und Teile. Alle verschlissenen oder beschädigten Teile sollten sofort aus dem Fahrzeug ausgebaut und erneuert.
2. Vorsicht beim Be- und Entladen von Gütern auf und abseits der Fahrzeuge.
3. Van Guard Accessories LTD und/ oder seinen Händlern keine Haftung für:
  - Sämtliche Produkte, die falsch montiert worden.
  - Alle Produkte, die auf die falsche Fahrzeug.
  - Alle Produkte, die nicht in irgendeiner Weise verändert oder verwendet für jeden Zweck, sie sind unbeabsichtigt.
4. Es ist wichtig, dass der Endbenutzer erhält dieses Dokument und die Anweisungen für eine zukünftige Verwendung aufbewahrt werden.



**DK**

1. Undersøg med jævne mellemrum alle løsele og fæstninger. Beskadigede eller slidte dele bør straks fjernes fra køretøjet og repareres eller erstattet.
2. Vær meget opmærksom ved lastning og losning af varer fra varevognens tag.
3. VanGuard Accessories Ltd og/eller deres distributører accepterer ikke ansvar for:
  - Produkter der ikke er monteret korrekt som angivet i monteringsvejledning.
  - Produkter der er blevet monteret på et køretøj, de ikke er beregnede til.
  - Produkter der er blevet modificerede på nogen måde eller bliver brugt på en måde, hvortil de ikke er beregnede.
4. Det er vigtigt, at dette dokument overdrages til slutbruger af produktet og at vejledning er gemt til senere brug.