

Marine Roof
Marinedach
Toit ouvrant Marine
Marine schuifdak
Tetti per la Nautica

Operating Instructions
Bedienungsanweisung
Notice d'utilisation
Bedieningshandleiding
Istruzioni per l'uso

20 Series
20er Serie
Série 20
20 Series
20 Series



TABLE OF CONTENTS / INHALTSVERZEICHNIS / INDEX / INHOUDSOPGAVE / INDICE

English	3
Deutsch	6
Français	9
Nederlands	12
Italiano	15

1 Operation

1.1 Overview

- A: Rear rails
 B: Sliding roof
 C: Release bar
 D: Guides

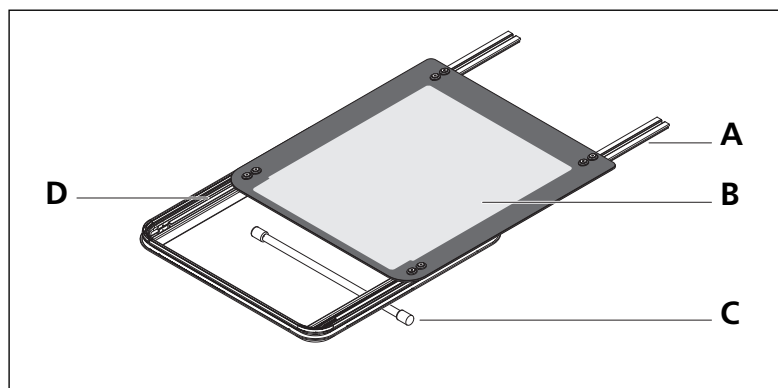
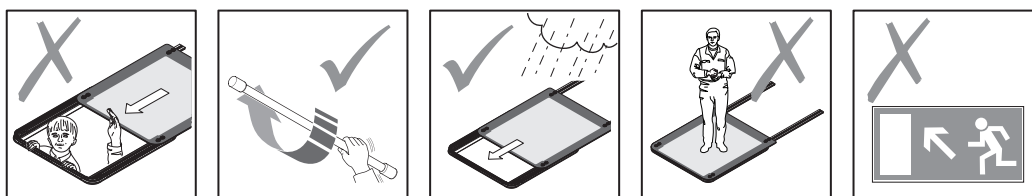

Fig. 1

1.2 Safety instructions



WARNING

- Take care not to hold any body parts, animals etc. through the roof opening when closing the roof!
- Always keep the release bar (C) in locked position, unless you want to open or close the roof.
 With the release bar unlocked, the roof can be opened from outside (burglary!) and can open or close unintentionally. This can cause injuries or leakage!
- Do not stand or walk on the roof!
- Do not use the sliding roof as escape hatch!
 Make sure that another hatch is accessible for emergencies.

1.3 Open and close the sliding roof

1. Rotate the release bar (C) to unlock the tilting and sliding mechanism
2. Pull the release bar to move the sliding roof to the desired position
3. Rotate the release bar as far as possible to lock the roof in the new position

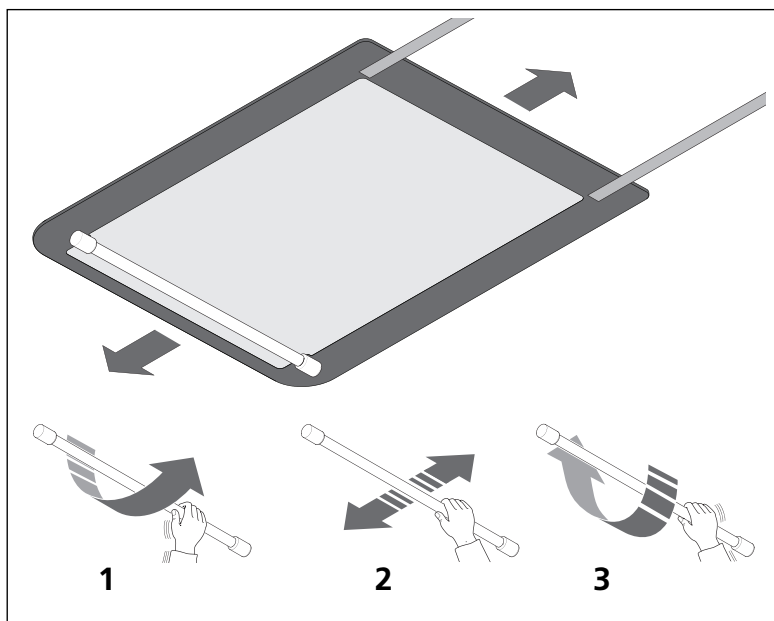

Fig. 2



NOTE

Do not to open the sliding roof if there is moisture on the panel.

2 Maintenance

- Clean the sliding roof regularly.
- Wash the roof with lukewarm water with a professional marine cleaning product. Then rinse with clean water.
- Apply a thin layer of grease (Isoflex® Topas L32) to the inside of the rear rails (A) and guides (D) to ensure smooth sliding.
- Never use:
 - Alkaline products containing sodium solutions;
 - Acid products like muriatic or those containing phosphor;
 - Steel wool, abrasives or sandpaper;
 - Cleaning products for glass containing alkaline, which can corrode aluminium.

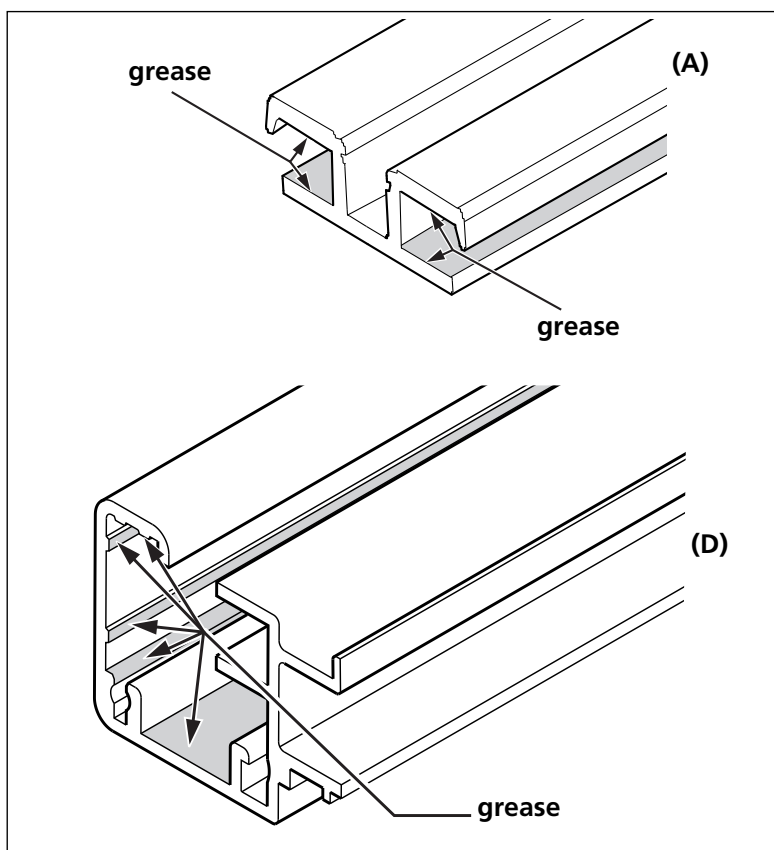

Fig. 3

3 In case of failure

- Poor opening/tilting of the roof:
 - Clean the seal with a mild detergent and open/close the roof again.
- Poor sliding of the roof:
 - Clean the inside of the rear rails (A) and guides (D)
 - Apply grease to the inside of the rear rails and guides.
See Fig. 1 and Fig. 3 and paragraph 2: "Maintenance".
- If the roof still does not move smoothly, please contact the supplier of the boat for maintenance/repair.

4 Warranty

Webasto guarantees the quality and correct operation of this sliding roof. The limited warranty covers both parts and labour and is valid for 3 years after date of first delivery of the boat.

The warranty applies only when the sliding roof has been installed by a Webasto authorized shipyard or installer and in accordance with Webasto installation instructions.

Defects and malfunction caused by incorrect handling, misuse, lack of reasonable and necessary maintenance, accident and broken panel are not covered by this warranty.

The warranty is only valid when proof of purchase can be submitted.

In multilingual versions the English language is binding.

Im Fall einer mehrsprachigen Version ist Englisch verbindlich.

Dans le cas d'une version redigee en plusieurs langues, l'anglais est alors la langue qui fait foi.

Bij een meertalige versie is de Engelse versie bindend.

Nel caso di una versione plurilingue l'inglese è vincolante.

Webasto Product International NL

Constructieweg 47

NL - 8263 BC Kampen

The Netherlands

Phone: +31 (0) 38 337 11 37

Fax: +31 (0) 38 332 51 81

E-mail: info.nl@webasto.com

Internet: www.webasto.com