

18T 4013

Ford Edge, Md. 04/2016

Trend / Titanium / Vignale

EU-pedestrian protection bar 60 mm with cross pipe 42 mm

EU-Personenschutzbügel 60 mm mit Querrohr 42 mm

Protection avant, homologuée CEE, 60 mm, traverse 42 mm

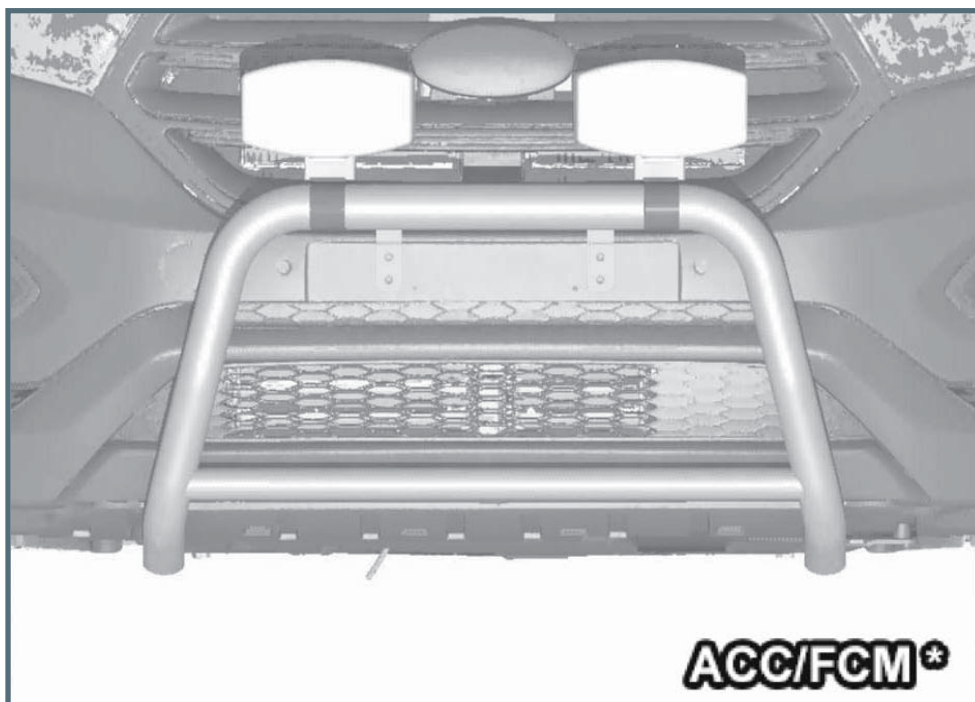

*Compatible with Automatic Cruise Control /Forward Collision Mitigation
Kompatibel mit Abstandsregeltempomat /Auffahrvermeidungs-oder warnsystem
compatible avec radar de régulation de distance/ freinage autonome d'urgence



ASSEMBLY INSTRUCTION

Montageanleitung • Instructions de montage

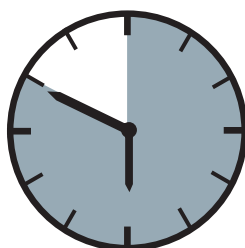

50 Minuten

Artikel-Nr:
18T4013 stainless steel
18T5013 black steel

Revision 3: 06.03.2018



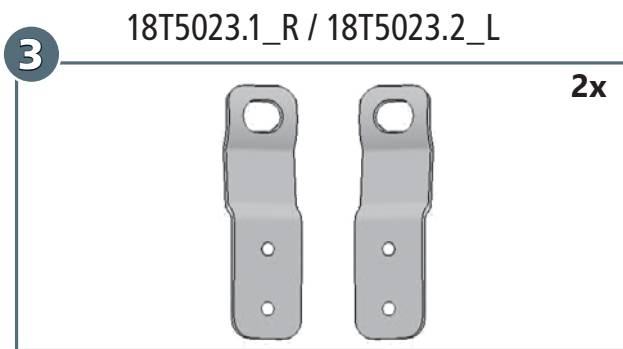
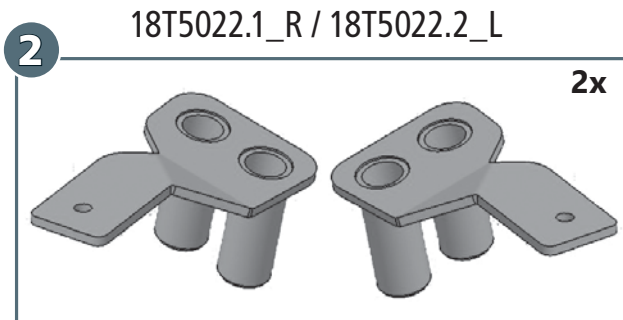
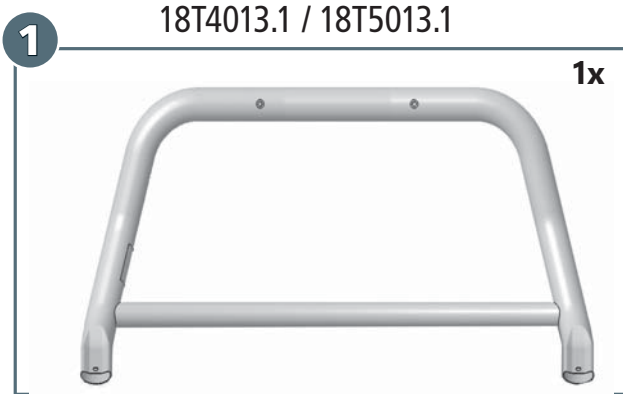
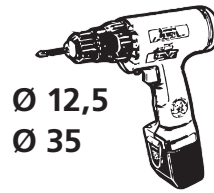
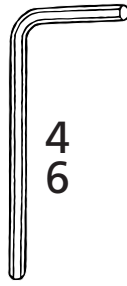
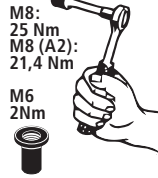
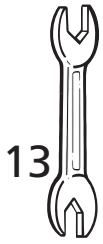

	M6x25; DIN 7991 Zn	4x
	M8x25; DIN 912 Zn	4x
	M8x25; DIN 933 A2	2x
	M8x35; DIN 933 Zn	2x
	Ø 8; DIN 127 Zn	6x
	Ø 8; DIN 127 A2	2x
	Ø 8,4; DIN 125 Zn	4x
	Ø 8,4; DIN 9021 A2	2x
	Ø 8,4; DIN 9021 Zn	2x
	Getowell M6	4x
	SW 13	2x

