

# 17X 4213

## Suzuki Vitara, Md. 04/2015

EU-pedestrian protection bar 60 mm with cross pipe 42 mm

EU-Personenschutzbügel 60 mm mit Querrohr 42 mm

Protection avant, homologuée CEE, 60 mm, traverse 42 mm



\*Compatible with Automatic Cruise Control /Forward Collision Mitigation  
Kompatibel mit Abstandsregeltempomat /Auffahrvermeidungs-oder warnsystem  
compatible avec radar de régulation de distance/ freinage autonome d'urgence

# ASSEMBLY INSTRUCTION

## Montageanleitung • Instructions de montage

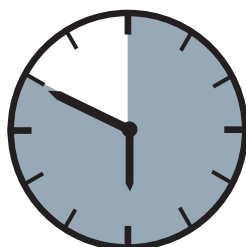

50 Minuten

### Artikel-Nr:

17X4213 stainless steel

17X5213 black steel

Revision 3: 31.03.2016

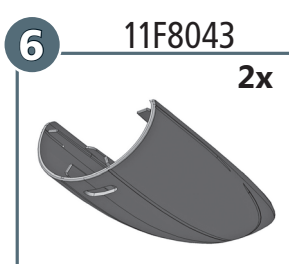
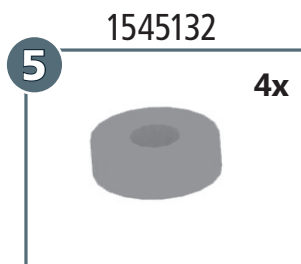
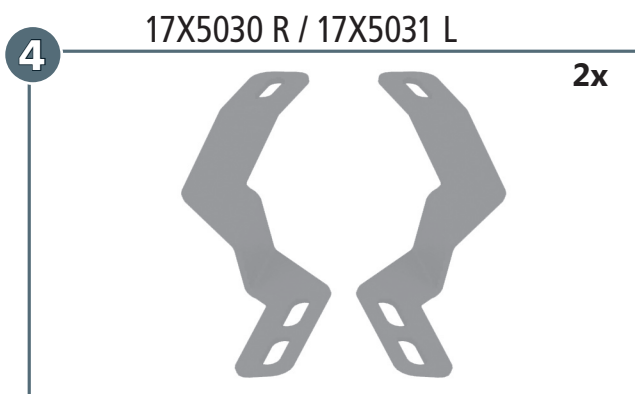
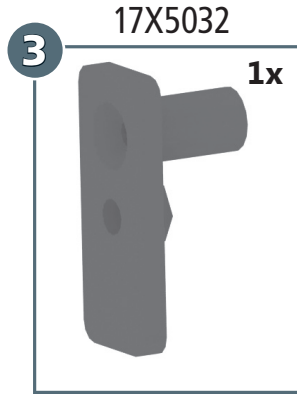
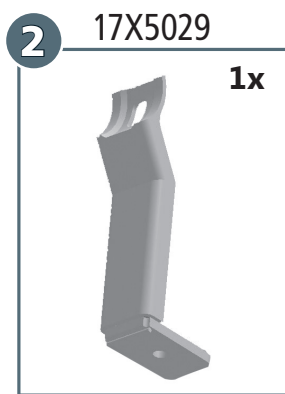
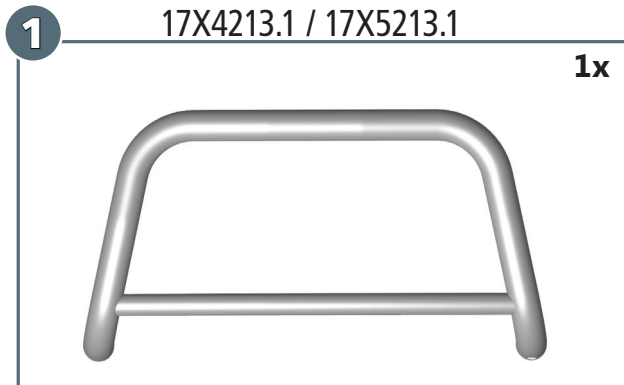
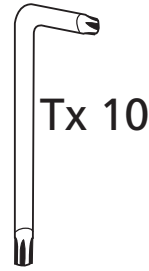
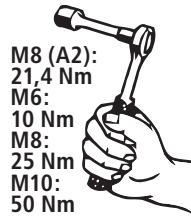

<b>a</b>		M8x40; DIN 7991 Zn	<b>1x</b>
<b>b</b>		M8x20; DIN 912 A2	<b>2x</b>
<b>c</b>		M8x30; DIN 933 Zn	<b>1x</b>
<b>d</b>		M8 x 25; DIN 933 A2	<b>1x</b>
<b>e</b>		M10 x 40 x 1.25 ; DIN 961 Zn	<b>4x</b>
<b>f</b>		Ø3,5 x 13; ähnl. DIN 7981B A2	<b>2x</b>
<b>g</b>		Ø 8; DIN 127 A2	<b>3x</b>
<b>h</b>		Ø 8; DIN 127 Zn	<b>1x</b>
<b>i</b>		Ø 10; DIN 127 Zn	<b>4x</b>
<b>j</b>		Ø 4,2; DIN 9021 A2	<b>2x</b>
<b>k</b>		Ø 8,4; DIN 9021 Zn	<b>1x</b>
<b>l</b>		Ø 8,4; DIN 125 A2	<b>2x</b>
<b>m</b>		Ø 8,4; DIN 9021 A2	<b>1x</b>
<b>n</b>		Ø 10,5; DIN 9021 Zn	<b>4x</b>

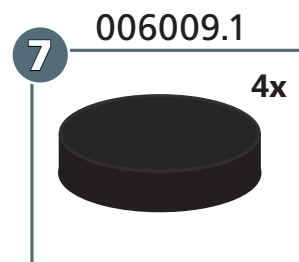

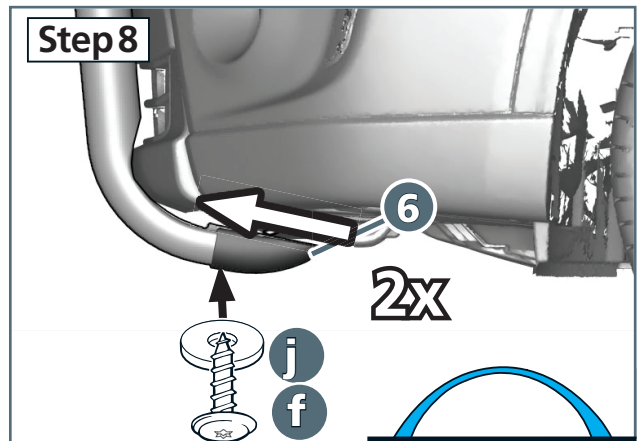
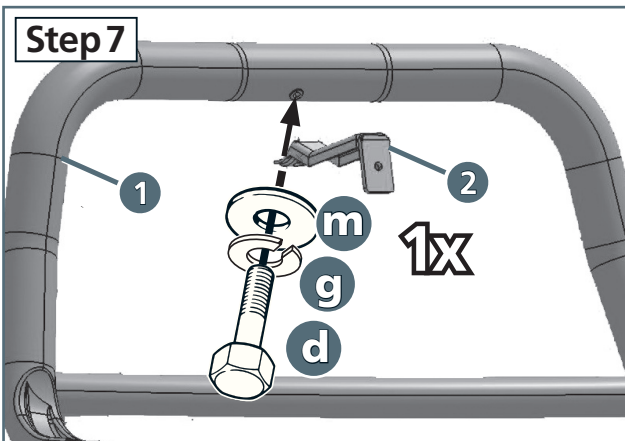
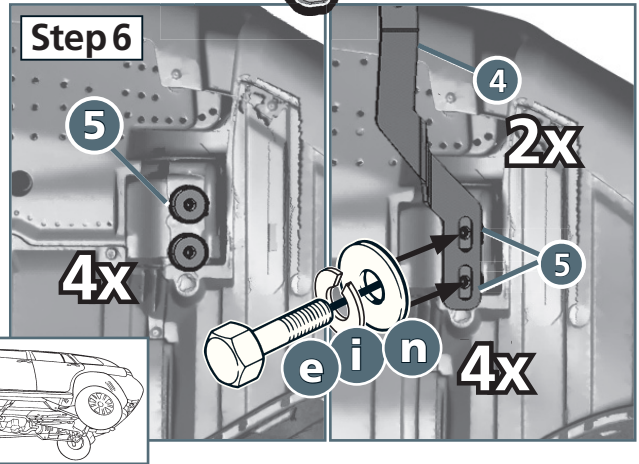
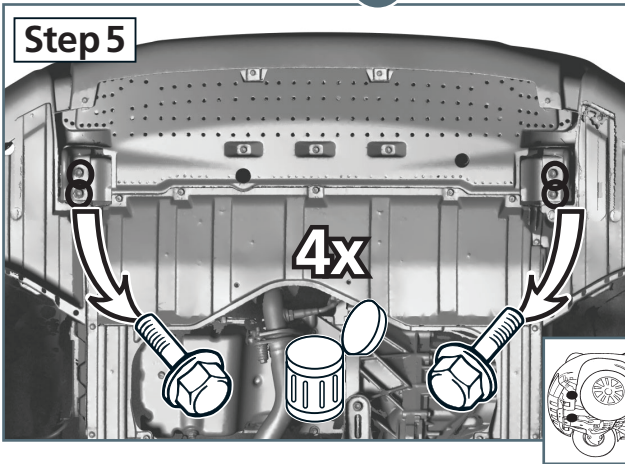
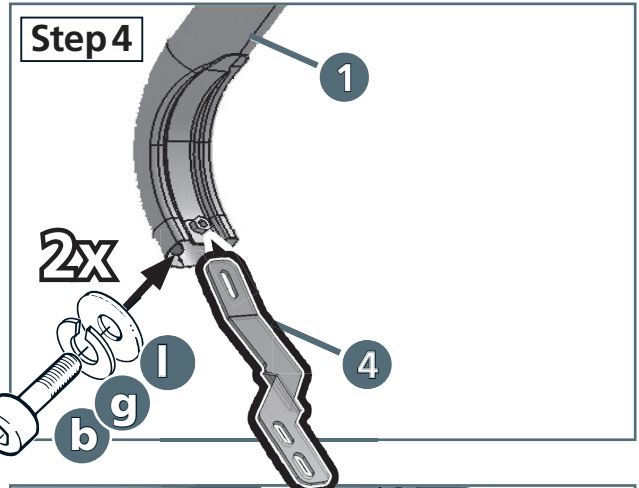
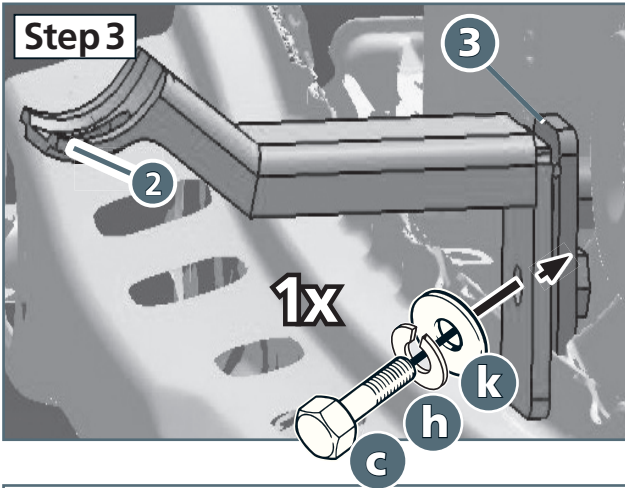
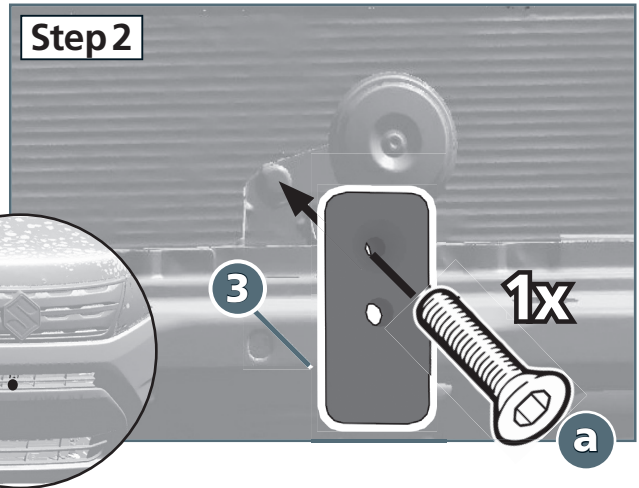
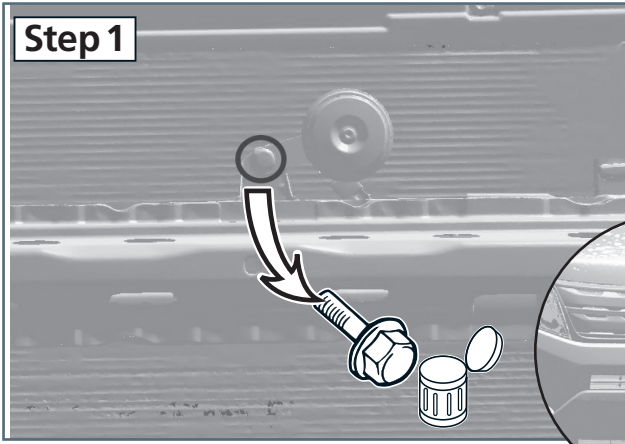



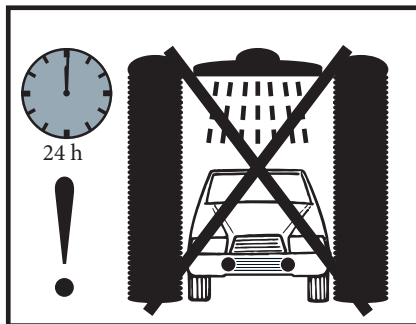
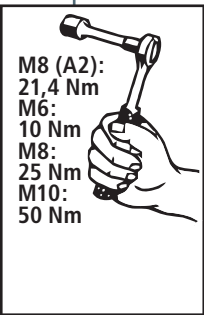
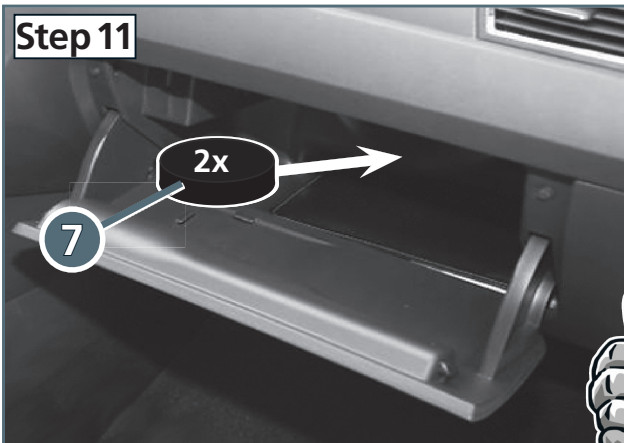
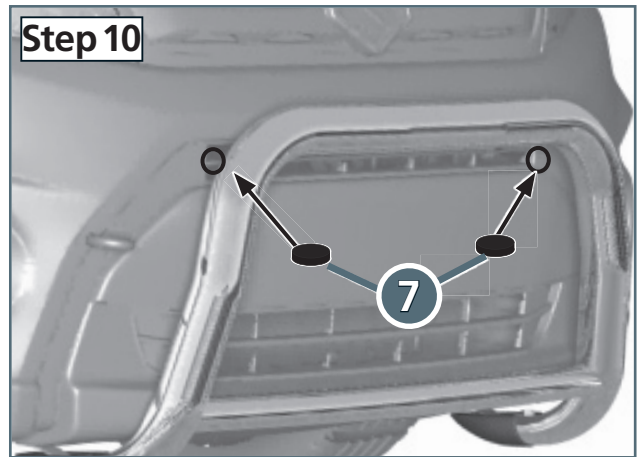
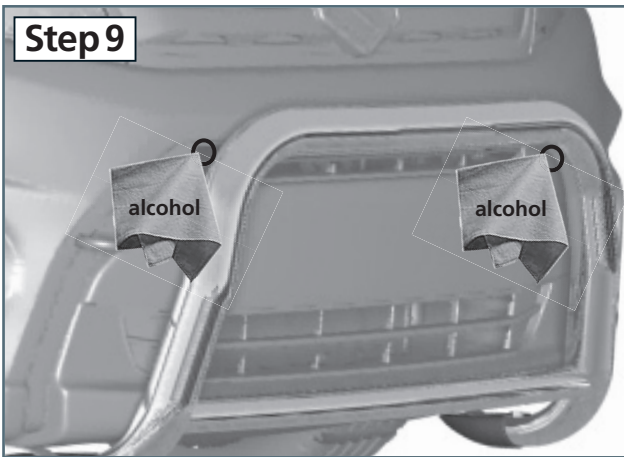

Die Funktion des PDC ist eingeschränkt  
 The function of the PDC will be restricted  
 La fonction de la pdc est limitée  
 La función de la PDC se restringirá  
 Funktio PDC on rajoitettu  
 Funkce PDC bude omezeno  
 Funksjonen til PDC vil være begrenset  
 Funktionen för PDC kommer att begränsas