

**17A
4213**

Mercedes V-Klasse Md. 05/2014

EU-pedestrian protection bar 60 mm with cross pipe 42 mm

EU-Personenschutzbügel 60 mm mit Querrohr 42 mm

Protection avant, homologuée CEE, 60 mm, traverse 42 mm



*Compatible with Automatic Cruise Control /Forward Collision Mitigation
Kompatibel mit Abstandsregeltempomat /Auffahrvermeidungs-oder warnsystem
compatible avec radar de régulation de distance/ freinage autonome d'urgence

ASSEMBLY INSTRUCTION

Montageanleitung • Instructions de montage

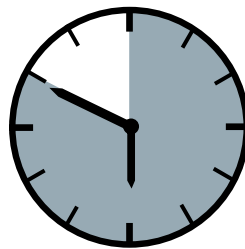

50 Minuten

Artikel-Nr:

17A4213 stainless steel

17A5213 black steel

Revision 5: 14.03.2016

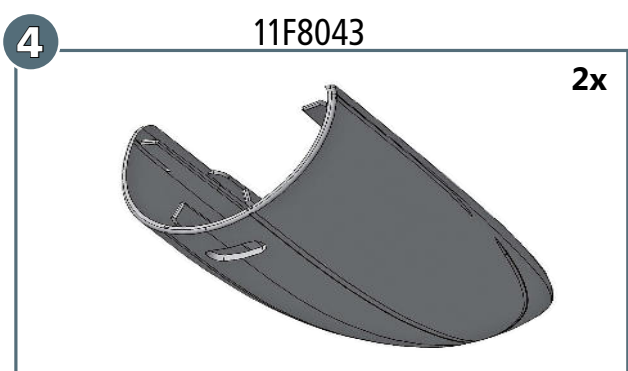
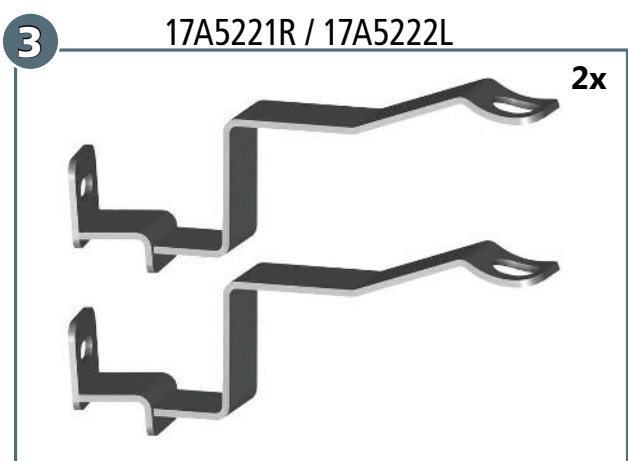
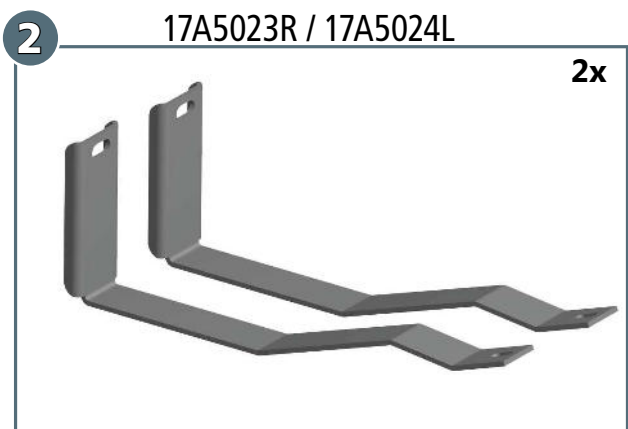
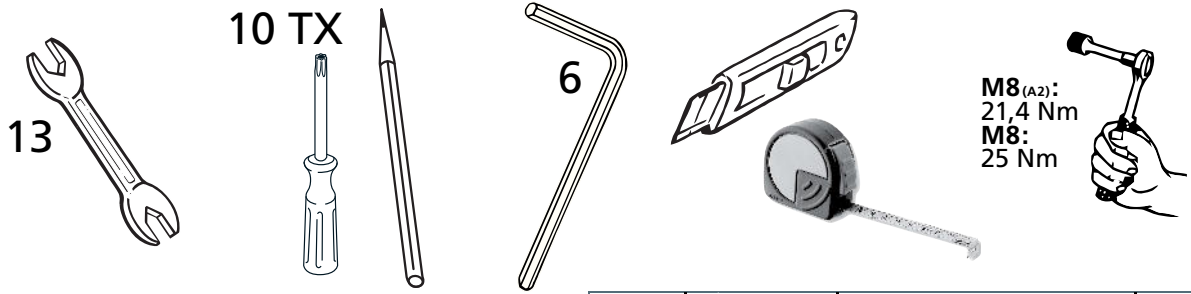

a		M8 x 25; DIN 933 Zn	2x
b		Ø 8,4; DIN 9021 Zn	6x
c		Ø 8; DIN 127 Zn	2x
d		M8; DIN 934 Zn	2x
e		M8 x 30; DIN 933 A2	2x
f		Ø 8; DIN 127 A2	4x
g		Ø 8,4; DIN 9021 A2	4x
h		SW 13	2x
i		M8 x 20; DIN 912 A2	2x
j		Ø 3,5 x 13; DIN ähnl. 7981B A2	2x
k		Ø 4,2; DIN 9021 A2	2x

