



# OWNERS/INSTALLATION MANUAL

## WhisperPower battery charger WP-BC Supreme-Pro 40 / 60 / 80 / 100A



### Professional battery charger



**TABLE OF CONTENTS**

1. General introduction	6. WhisperConnect CAN bus
2. Warranty & safety instructions	7. EC declaration of conformity
3. Operation instructions	8. Trouble shooting & fault finding
4. Installation instructions	9. Technical specification
5. Configuration settings	

### 1. GENERAL INTRODUCTION

#### 1.1 Overview

All users/operators of the WhisperPower range of heavy duty battery chargers (WP-BC Supreme-Pro) must ensure that they read this manual before operating this equipment. This manual includes essential safety & operating guidelines to ensure the safe & effective use of the WP-BC Supreme-Pro Charger. This manual also includes a 'trouble shooting & fault finding' guide to support operators in the identification & resolution of operating issues.

Copyright© 2018 WhisperPower.

All rights reserved. No part of this publication may be reproduced, distributed, or transmitted in any form or by any means, including photocopying, recording, or other electronic or mechanical methods, without the prior written permission of WhisperPower.

#### 1.2 Scope

The contents of this manual apply only to standard versions of the WP-BC Supreme-Pro Charger supplied by WhisperPower. For other models see other manuals available on our website: [www.whisperpower.com](http://www.whisperpower.com)

#### 1.3 Safety instructions & warnings

Symbols are used in this manual to identify safety instructions & warnings.

##### WARNING

The WARNING symbol identifies a risk of injury to the operator or damage to the WP-BC Supreme-Pro Charger, if the instructions & guidelines contained in this manual are not followed.



##### CAUTION!

The CAUTION symbol highlights an operating or installation procedure where the operator and/or installer must give special attention to prevent damage to the WP-BC Supreme-Pro Charger.

#### 1.4 Identification markings

The identification label includes important information for the service & maintenance of this unit. It is located on the right-hand-side of the WP-BC Supreme-Pro Charger (see figure 1).



Figure 1: Identification label



##### CAUTION!

Do not remove the identification label.

#### 1.5 Liability

WhisperPower accepts no liability for consequential damage due to use of the WP-BC Supreme-Pro Charger including those caused by possible errors in the manuals. This document describes the state of this product at the time of its publication. WhisperPower reserves the right to revise and improve its products.

## 2. WARRANTY & SAFETY INSTRUCTIONS READ AND SAVE THESE INSTRUCTIONS



##### WARNING

This chapter contains important safety and operating instructions to enable safe & effective use of the WP-BC Supreme-Pro Charger in marine, mobile & stationary applications.

#### 2.1 General

- Read this manual plus all external warnings & caution labels on the WP-BC Supreme-Pro Charger and associated battery system before operating the charger.
- Fire risk - Do not cover or obstruct the ventilation openings. Ensure the installed location of the WP-BC Supreme-Pro Charger is well ventilated.
- Electric shock risk – WP-BC Supreme-Pro Charger must only be installed & operated in an environment free from rain, snow, spray, moisture, excessive pollution, dust and condensation. Disconnect the WP-BC Supreme-Pro Charger from both AC and DC electrical system before attempting any maintenance or cleaning. Only turning off the controls will not reduce this risk.
- Do not use modify, use additional parts or spare parts not recommended or supplied by WhisperPower as this may result in a risk of fire, electric shock, or injury to persons and/or damage to equipment.
- The WP-BC Supreme-Pro Charger has been designed and tested in accordance with international standards. It is designed to be permanently connected to an AC and DC electrical system. Installation and maintenance of the WP-BC Supreme-Pro Charger may only be carried out by qualified, authorised and trained technicians or electricians, in-line with the local standards and regulations. For example, if installed in a marine application in the United States, external connections to the WP-BC Supreme-Pro Charger must comply with the United States Coast Guard Electrical Regulations (33CFR183, Sub part I).
- All wiring must be of the correct gauge for the current (ampere) rating of the installed WP-BC Supreme-Pro Charger. All wiring & electrical conditions must be in good electrical condition and inspected annually.
- Do not operate the WP-BC Supreme-Pro Charger if it has received a shock load, been dropped, or otherwise damaged in any way; it should be inspected by a qualified technician before further use.
- The WP-BC Supreme-Pro Charger must not be opened or disassembled (except for the connection compartment, see chapter 4). There are no serviceable parts inside the cabinet. Only qualified, electrician installers are authorised to open the connection compartment. The unit must only be serviced or repaired by an authorised and trained service technician. Incorrect reassembly may result in a risk of electric shock or fire.
- The WP-BC Supreme-Pro Charger must be grounded via the AC-input ground terminal using a suitable equipment grounding conductor. Grounding and all other wiring must comply with local codes and regulations.
- Creating a short circuit across, or reversing polarity of the terminals will lead to serious damage to the batteries, the WP-BC Supreme-Pro Charger and the wiring as well as accessories. Fuses will not prevent damage caused by reversed polarity and the warranty will be void.
- In case of fire, you must use fire extinguishers suitable for electrical equipment.
- This appliance can be used by children aged from 8 years and above and persons with reduced physical, sensory or mental capabilities or lack of experience and knowledge if they have been given supervision or instruction concerning use of the appliance in a safe way and understand the hazards involved.
- Children shall not play with the appliance. Cleaning and user maintenance shall not be made by children without supervision.
- Do not recharge non-rechargeable batteries.
- If the supply cord is damaged, it must be replaced by the manufacturer or its service agent or a similar qualified person in order to avoid a hazard.

#### 2.2 Risk of gas or dust explosions



**1 WARNING** – risk of explosive gases. Normal operation & charging of some battery types generates explosive gases. Working in the vicinity of these battery types (such as lead acid batteries) is dangerous. Therefore, it is important that this manual is read, and the instructions followed for the operation of this charger.

**2** To reduce the risk of a battery explosion, follow these instructions plus those from the battery manufacturer. The manufacturer recommendations for any equipment intended for use near the battery must be followed. Review cautionary marking on these products.



**3 DANGER** – Never use the WP-BC Supreme-Pro Charger in locations where there is danger of gas or dust explosion or in an area in which ignition-protected equipment is used. Ensure that the area around the battery is well ventilated during charging (refer to the battery manufacturers recommendations).

#### 2.3 Warnings regarding the use of batteries

- Do not work alone – Always ensure someone is close enough to provide assistance if required when working on a battery system.
- Ensure plentiful fresh water and soap are available nearby in case battery acid contacts skin, clothing, or eyes.
- Ensure complete eye and appropriate skin protection are worn when working on a battery system. Avoid touching eyes whilst working on or near a battery.
- In the event that battery acid contacts the skin or clothing, wash immediately with soap and water. If acid enters eye, immediately flood the eye with running cold water for at least 10 minutes and seek medical attention immediately.
- NEVER smoke or allow any other source of ignition such as a spark or flame near a battery or engine.
- Do not short circuit batteries. This can cause sparks and/or overheating that may result in an explosion or fire. Extra care is required to prevent the risk of dropping a metal tool onto a battery. Remove personal metal items such as rings, bracelets, necklaces, and watches when working with a battery. A battery can produce a short-circuit current high enough to weld a ring or similar to another piece of metal, causing a severe burn.
- Only use the WP-BC Supreme-Pro Charger for charging Lead acid, NiCad and lithium-ion batteries plus to supply consumers attached to these batteries, in permanent connected systems. Do not use the WP-BC Supreme-Pro Charger for charging dry cell batteries (commonly used with home appliances). These batteries may burst and cause injury to persons and damage to property.
- Do not charge batteries when frozen.
- To prevent damage to your batteries, do not exceed their recommended charging voltage & discharge current limits.
- Before removing a battery ensure that all accessories are turned off and remove the grounded terminal from the battery first (to prevent a spark).
- Ensure batteries are mounted securely enough to prevent them become loose during normal operation or during extreme events such as collisions. Always use suitable handling equipment for the transportation of batteries.

#### 2.4 Medical or life support applications

The WP-BC Supreme-Pro Charger is not sold for use in any medical equipment intended as a component of any life support system unless a specific written agreement authorising such use is obtained from WhisperPower. Such agreement will require the equipment manufacturer either to contract additional reliability testing of the WP-BC Supreme-Pro Charger and/or to commit to undertake such testing as a part of the manufacturing process.

In addition, the manufacturer must agree to indemnify WhisperPower against any claims arising from the use of the WP-BC Supreme-Pro Charger in the life support equipment.

#### 2.5 Warranty specifications

WhisperPower guarantees that this unit has been built according to the legally applicable standards and specifications. Any work carried out must be in accordance with the guidelines, instructions and specifications contained in this user's manual. Failure to comply may result in damage or reduced performance of the unit and the guarantee may be invalidated. The guarantee is limited to the cost of repair and/or replacement of the supplied unit. Other associated costs such as the installation labour or shipping of the defective parts are not covered by this guarantee.

#### 3. OPERATION INSTRUCTIONS

##### 3.1 Introduction

The WP-BC Supreme-Pro Charger series is a range of fully-automatic, high efficiency, battery chargers/rectifiers, developed and produced by WhisperPower. The WP-BC Supreme-Pro Charger charges batteries rapidly and safely whilst simultaneously supplying power to the connected consumers. In addition, the WP-BC Supreme-Pro Charger is secured against short circuit, overload and high temperatures in an industrial environment.



**CAUTION** – Before switching on for the first time, the equipment must be installed properly (see section 4) and the correct charging curves for the connected batteries must be set.

##### 3.2 Quick reference guide

Normal operation only involves connecting AC power and switching the device on. All functions operate automatically to maintain the connected battery in optimum condition. DC loads may also be powered on during battery charging. Information is readily available on the Liquid Crystal Display (LCD) on the front panel, in combination with the push button switches below it. Details of the advanced operation features are provided in 3.3 below.

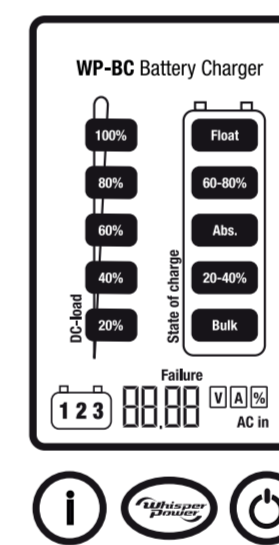

##### 3.2.1 Powering on

The battery charger is switched on by pressing and holding the power button switch on the right-hand bottom of the display for approximately 1 second with a connected grid supply. Once switched on the button will light up green and charging of connected batteries starts immediately.

##### 3.2.2 Powering off

The battery charger is switched off by pressing and holding the power button for 1 second. However, during normal operation, it is not necessary to power down. As long as the batteries remain electrically connected to the charger the charger settings remain unchanged. After 1 hour the power drain from the batteries is minimised to enable the system to be on standby for periods of time when an AC source may not be available.



##### WARNING

Switching off the WP-BC Supreme-Pro Charger does not isolate the connection to the AC source or the batteries. This means that parts of the unit remain electrically live.

#### 3.3 Functions and detailed operating modes

##### 3.3.1 Theory of operation

The battery charger is equipped with an intelligent multistage charge characteristic that delivers the optimum charge rate for the connected batteries. The three charging stages are 'Bulk', 'Absorption' and 'Float.'

During Bulk mode charging, maximum power is delivered to the battery until the battery voltage has risen to a pre-determined level or until the bulk timer has expired. Further charging is accomplished during the Absorption mode, where lower current is transferred at a relative high Absorption voltage. When charging current drops below the 'Return-Amps' level or when timed out, the Absorption mode continues for the set time duration.

Following the Absorption mode, the charger is set to Float mode charging, where the voltage level is decreased to a safe value for prolonged battery life. At pre-set intervals, the charging mode is forced to Bulk charging for a limited time, to keep batteries charged 100% and eventually equalise individual cell voltage within the battery.

When the Battery Temperature Sensor is connected, the charge voltage will be automatically adjusted for the connected batteries based on the measured temperature. In the same way, when Voltage Sense wires are connected, the voltage drop across the cables is compensated for. The above cycle applies to the main batteries connected to output 1. When slave batteries are connected to outputs 2 and/or 3, these will follow the characteristic set by the main battery but at limited output currents.

##### 3.3.2 Local Read Out Module (ROM)

The ROM is located on the Liquid Crystal Display on the front of the charger.

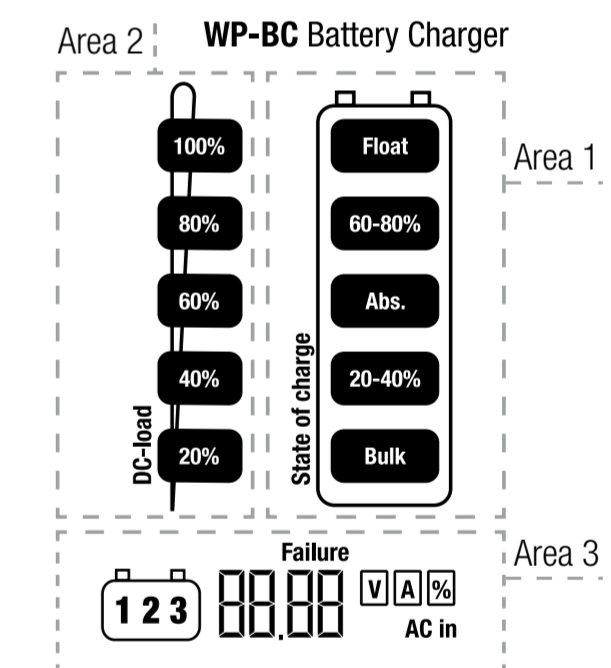

Figure 2: Front Panel

##### 3.3.2.1 Battery State Of Charge (SOC)

The right bar graph (Area 1 in fig.2) represents the actual charging state. An overview of the active segments of the charge bar during a charging cycle is illustrated in figure 3.

Heavy-duty range of battery chargers for domestic, maritime, recreational vehicle, residential or industrial use. Also suitable for use as a power supply. Wide voltage input range, from 120/230VAC (50/60Hz) with multiple DC outputs. Includes the most advanced switched mode technology to ensure compactness and low weight. Charger is in conformity with the most stringent global standards including CE, ABYC A-31 and IEC60945.





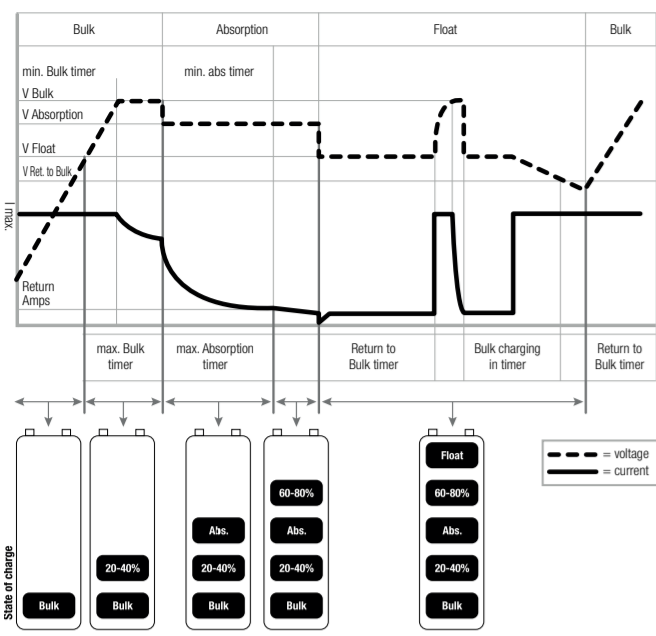

Figure 3: State of Charge bar operation during charging cycle

**NOTE:** When the charger is switched off, the segments of the charge bar represent a measured battery voltage to indicate the charge level of batteries.

### 3.3.2.2 Charger output

On the front of the WP-BC Supreme-Pro Charger, the left bar graph of the Liquid Crystal Display (Area 2 in fig.2) represents the charging current. The more segments illuminated, the higher the total charging and/or DC consumption current. A segment turns on for every 20% of consumption in relation to the specified maximum current.

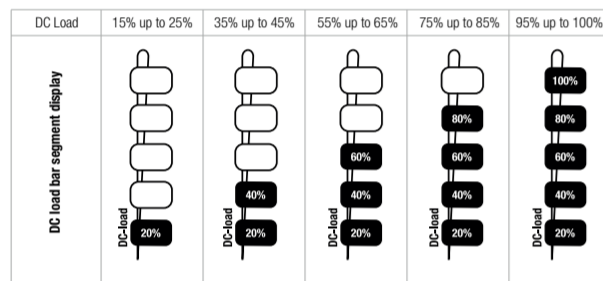

Figure 4: DC Load bar

**NOTE:** for values in between indicated columns, the respective segment flashes on and off

### 3.3.2.3 Additional read outs

Specific information that counteracts with the pushbutton switches is visible at the bottom of the LCD display (Area 3 in fig.2).

- In the centre there is a 4 digit display of voltage, current or percentage load of the selected battery bank. Also, other information e.g. software version or error number may be displayed here.
- In the top centre of Area 3, 'Failure' is highlighted whenever a fault is detected. The type of fault is shown on the 4 digit display, by showing a Fault, a Warning and/or an Error code(s) sequentially.
- On the left side, the selected battery bank is shown. The selected battery bank can be changed by pressing the 'I' button.
- On the right-hand side of Area 3, a block highlighting 'V', 'A' or '%' shows the displayed entity. Pressing button 'Select' will sequence through different entities of the selected battery bank.
- At the bottom on the right-hand side, 'AC in' is highlighted whenever a valid AC input is detected.

### 3.3.3 Push buttons

Three push buttons are located under the Liquid Crystal Display with multi-colour backlight illumination. These buttons interact with the LCD text in the bottom part of the display, as described here.

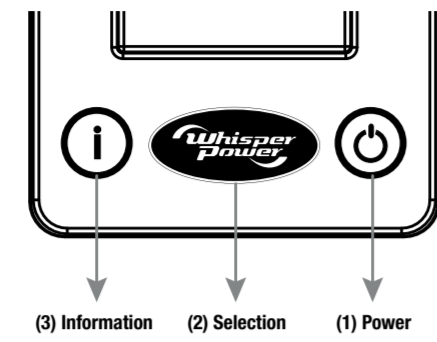

Figure 5: Pushbutton switches

#### (1) POWER ON button

Press the "POWER ON" button for 1 second to switch the 'AUTO ON' function on or off  
 Green illuminated = Charger ON (Charger is delivering power)  
 Orange flashing = Charger OFF (Charger shuts down)  
 Orange illuminated = Charger OFF (Charger off due to fault occurred, including AC fault)

**NOTE:** Besides the colour indication of the button, a marking 'AC in' appears at the right-hand bottom of the LCD display when valid AC input voltage is detected

#### (2) SOURCE SELECTION button

Press the "SELECTION" button briefly to select the voltage (V), current unit (A) or percent unit (%) in the monitoring space at the bottom of the LCD display; the selection information is indicated by a block marking around either 'V', 'A' or '%' at the right-hand bottom of the LCD display.

A second function of this button is activated when the button is pressed and held (more than 5 seconds). When done during operation, the Firmware Version of DSP, MCU and LCM are displayed sequentially by short pressing (2 seconds) this button. Pressing & holding the button again (more than 5 seconds) or waiting for 20 seconds returns the screen to the normal display.

Lastly, pushing both the "SELECTION" and "INFORMATION" buttons at the same time for 5 seconds enters another advanced function. This enables the 'USB-mode' where firmware may be updated by an installer using a preconfigured USB stick. Pushing this combination of buttons again for 5 seconds returns to normal operation.

#### (3) Additional INFORMATION Button

Press "INFORMATION" button to select the battery bank (1, 2 or 3) that you want to monitor; the selected battery bank is shown on the bottom left-hand side of the LCD display. Please note that this function remains operative when the charger is switched off.

### 3.4 Status input/output remote interface

Installing the following external hardware provides several additional functions. Please contact your installer to correctly install any of the following.

#### 3.4.1 Remote Panel

A basic or an advanced remote panel may be connected to the charger and installed in another, more convenient location. The state of charge and load bar is displayed on this panel.

#### 3.4.2 Limitation of charge current

A 1 kilo-ohm linear potentiometer or a fixed-value resistor may be connected to limit the maximum charge current. This may be required when shore grid or mains power is restricted or when the battery capacity is low. As opposed to limiting current from the front or (advanced) remote panel, the external resistance limits the output current permanently.

### 3.4.3 Temperature compensation

By installing the battery temperature sensor, the charge voltages are automatically adjusted based on the measured temperature. This can increase the battery's lifetime substantially and therefore, significantly reduce the battery replacement costs.

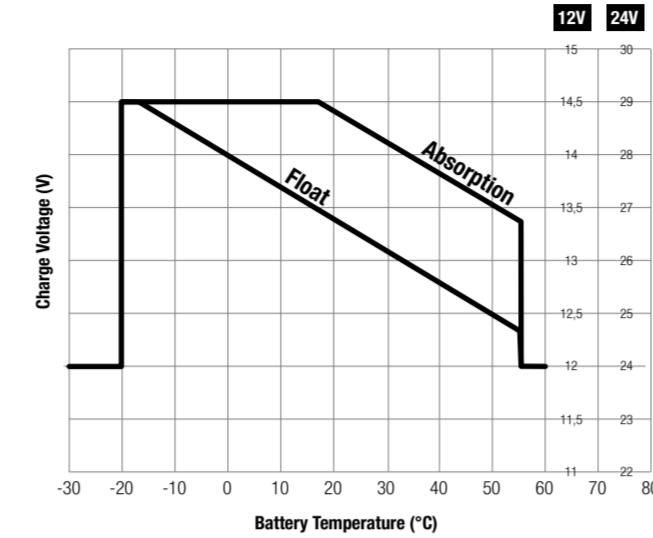

Figure 6: Temperature compensated charging

See figure 6. When the battery temperature is low, the charge voltage increases. On the other hand, when the battery temperature is high, the charge voltage is decreased. Correction is set to -5mV/°C per cell, referenced to 25°C. Adjusting the charge voltage based on measured temperature prevents damage to the batteries from overcharging and gassing.

### 3.4.4 Compensation of voltage drop

The WP-BC Supreme-Pro Charger can automatically compensate for the voltage drop occurring over the DC cables. For this purpose, the WP-BC Supreme-Pro Charger is provided with terminals for voltage sense wires. The sense wires are connected as closely as possible to the batteries in order to charge them with the correct voltage. When only the minus sense wire is connected only the losses of the minus DC cable will be compensated. Connecting both cables will give the best result, all losses will be compensated up to a maximum of 1.5V in total.

### 3.4.5 Analogue remote inputs

As well as displaying information on a remote panel, control inputs can be remotely provided by connecting switches (or potential-free contact closures) to switch the charger on or off, and/or to force the charging state into 'Forced Float' mode.

### 3.4.6 Alarm outputs

The battery charger is equipped with an integrated alarm function. The alarm output signal operates on switch on/off and on failure functions of the charger. The maximum switch current of the relay is 1A and the voltage rating is 24 VDC. Exceeding the set points will activate the alarm.

### 3.4.7 WhisperConnect CAN bus

Connecting WhisperConnect enables digital communication (CAN-Open bus) to other WhisperPower equipment or a personal computer via a common bus structure. In this way, a power management system is possible, where communication between inverters, chargers, generators and many more items of electrical equipment is automatically achieved. As well as visualising parameters, setpoints for the charger may be programmed if sufficient rights are attained.

### 3.4.8 USB port

A USB port is provided for firmware & configuration settings upgrading of the charger. Contact our service desk when new software needs to be installed.

### 3.4.9 Charging a secondary battery bank

Many installations have a main battery set and an addition smaller (cranking) battery bank with the same voltage. It is possible to maintain this second and a third battery with the two 6A Slave Charger outputs of the battery charger.

## 4. INSTALLATION INSTRUCTIONS

During installation and commissioning of the WP-BC Supreme-Pro Charger, the safety instructions are applicable at all times (see chapter 2 of this manual). Please check the contents of the package before you start with the installation. The following items are included:

- The WP-BC Supreme-Pro battery charger of correct model and type;
  - A remote panel (incl. 15 metre cable);
  - Battery temperature sensor (incl. 6 metre cable);
  - Owners and installation manual;
- If one of these items is missing, please contact your supplier.

### 4.1 Installation environment

Choosing an installation location:

- Install the WP-BC Supreme-Pro Charger in a well-ventilated room protected against rain, snow, spray, vapour, bilge, moisture and dust.
- Ambient temperature: 0 to 60°C / 32°F to 140°F; (power derating occurs above 40°C / 104 °F to decrease the internal heat sink temperature).
- Humidity: 0-95% non-condensing.
- Never use the WP-BC Supreme-Pro Charger in a location where there is a danger of gas or dust explosions.
- Ensure that there are no obstructions to the airflow through the ventilation openings. No objects should be located within a distance of 10cm / 4 inches from the WP-BC Supreme-Pro Charger.
- Mount the WP-BC Supreme-Pro Charger vertically, with the connecting cables downwards.
- Do not install the WP-BC Supreme-Pro Charger in the same compartment as the batteries.



**CAUTION:** Before making the connection between the battery charger and the system, be sure that the AC and DC system are switched off. Remove the fuses to protect yourself against unexpected powering on.

### 4.2 Mounting

- Once the location for the WP-BC Supreme-Pro Charger is known and verified, unscrew the two Torx screws securing the lid of the wiring compartment.
- Locate the dimensioning drawing of your model on this sheet and mark the two top mounting positions on the wall. Pre-drill where necessary.
- Mount the unit by fixing the top bolts.

- Note:** Mounting screws are not provided as the requirement differs per installation. Choose a flat surface and M6 bolts to fix the unit securely.
- Now locate the bottom mounting hole positions from within the wiring compartment. Pre-drill and mount using a socket wrench with a shaft length of at least 160 mm.
  - Chargers should be installed lower as 2 meters height.
  - The length of the M6 bolt is not less than 10mm.

The configuration DIP switches is required. To operate (one of) The configuration DIP switches is required. To operate (one of) the DIP-switches, remove the top front cover of the charger by unscrewing the 4 Torx screws from the front, without connecting the cable to the Interface connection board. Locate the specific numbered DIP switch and use a small size screwdriver to (de)activate it. Close the front lid and mount the 4 screws.

### 4.4 CABLING



**CAUTION!** The wire and fuse sizes stated in this manual are provided as examples only. The required wire and fuse sizes may be different due to local applicable regulations and standards.

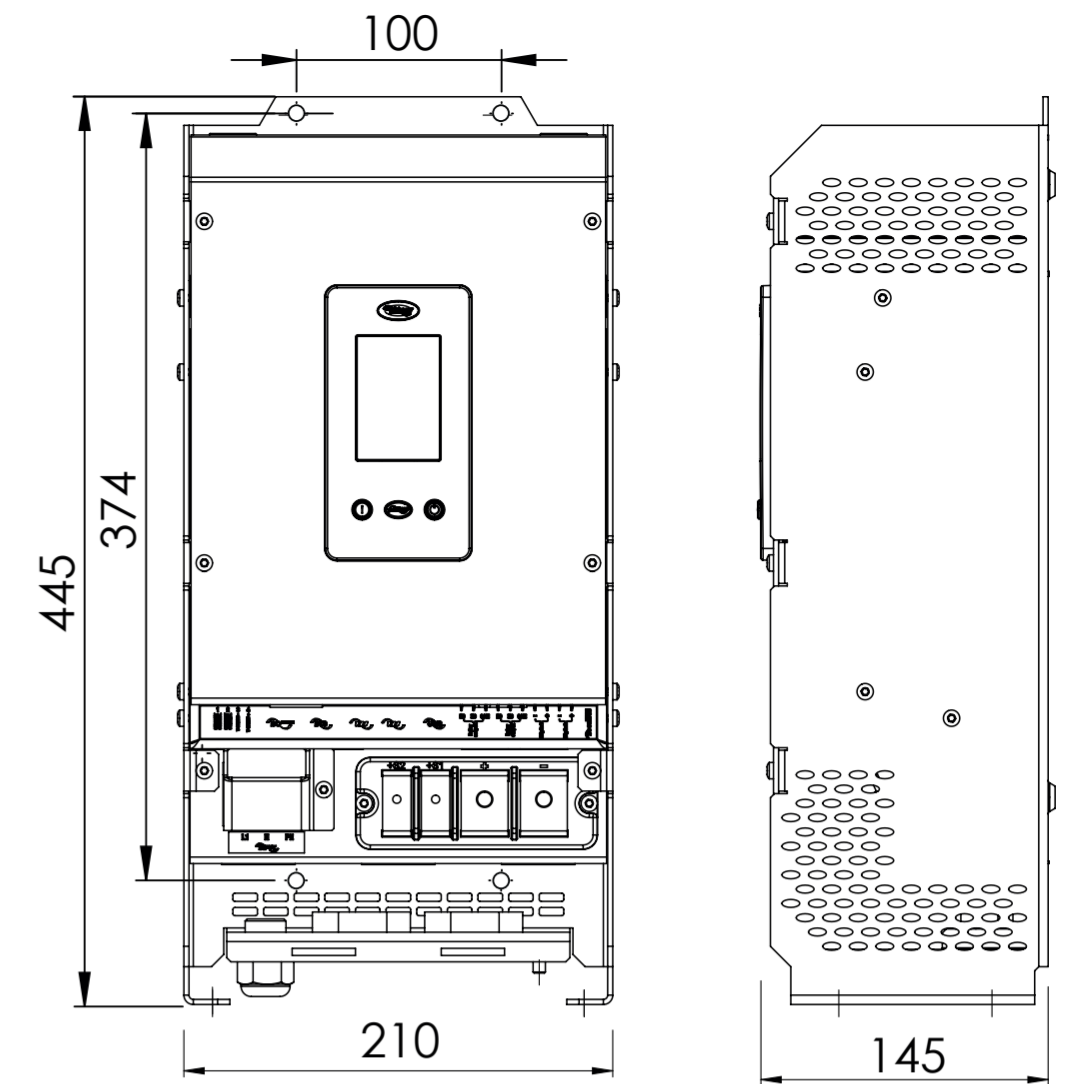

## ERROR CODES TABLE

ERROR CODE	DESCRIPTION	CHARGER OFF	"FAILURE"	RED POWER BUTTON	AUTO RESET	REMARKS
E01	Input frequency under limit	✓	✓	✓	✓	< 35Hz
E02	Input frequency above limit	✓	✓	✓	✓	> 70 Hz
E03	Input voltage under limit	✓	✓	✓	✓	< 80V
E04	Input voltage above limit	✓	✓	✓	✓	> 265V
E16	Fan Failure	✓	✓	✓	✓	
E17	Internal Under Temperature	✓	✓	✓	✓	
E18	Transformer Temperature over limit	✓	✓	✓	✓	
E19	Ambient Temperature over limit	✓	✓	✓	✓	
E20	HeatSink Temperature over limit	✓	✓	✓	✓	
E21	D2D HeatSink Temperature over limit	✓	✓	✓	✓	
E22	Battery Temperature abnormal	✓	✓	✓	✓	Output 24V / Off
E23	Bus voltage above limit	✓	✓	✓	✓	
E24	Battery 1 Voltage under limit of 20V		✓		✓	Recovers > 22V
E25	Battery 2 Voltage under limit of 20V		✓		✓	Recovers > 22V
E26	Battery 3 Voltage under limit of 20V		✓		✓	Recovers > 22V
E27	Output 1 Voltage above limit	✓	✓	✓		Resets by power off/on
E28	Output 2 Voltage above limit	✓	✓	✓		Resets by power off/on
E29	Output 3 Voltage above limit	✓	✓	✓		Resets by power off/on
E30	DIP switch 1~4 configuration error	✓	✓	✓		Recovers after only one of SW1~SW4 is set
E31	DIP switch 4 without user-defined profile	✓	✓	✓		download charger profile or DIP switch 4= off for reset
E34	Internal Communication failure	✓	✓	✓		(DSP<->-> MCU)
E35	EEPROM Failure	✓	✓	✓		(MCU Flash error)
E36	Incompatible Model Information	✓	✓	✓		internal software error
E37	Internal Communication failure		✓	✓		Output 24V / Off
E40	Digital Input 1 Active	✓	✓	✓	✓	(CHARGER OFF activated)
E50	DSP ADC sense circuit failure	✓	✓	✓		(PFC hardware ADC A2 failure)
E52	DSP ADC sense circuit failure	✓	✓	✓		(PFC hardware ADC A4 failure)
E55	DSP ADC sense circuit failure	✓	✓	✓		(DDC hardware ADC A7 failure)

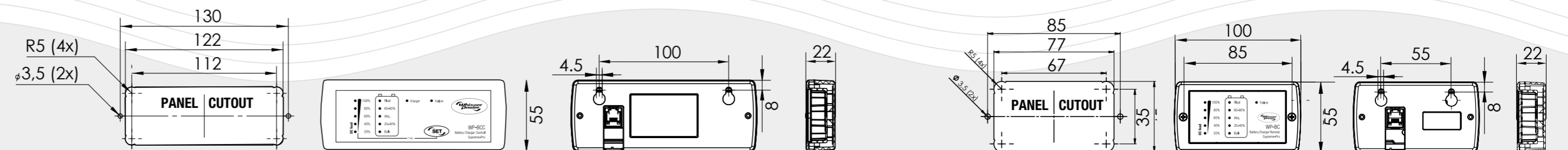



#### 4.4.1 AC wiring

Check that the voltage of your mains source or generator corresponds with the AC input voltage of the battery charger as mentioned on the type plate, see section 1.4. Using a Torx screwdriver, remove the lid covering the AC connection block. Strip the cable according to fig. 7. It is important that the green/yellow earth wire is  $\pm 1$  cm (0.4 inch) longer than the other wires. This is to reduce the risk of the ground/earth connection coming loose if the cable is accidentally pulled. Connect the green/yellow wire to PE, brown to L1 and the blue wire to the N terminal. For a safe installation the correct wire cross section must be applied. Don't use a cross section that is smaller than indicated. See the table below to select the appropriate cross section for the AC wiring (up to 6m / 20ft length):

#### AC input wire codes:

Model	Imax [A]	mm2	AWG	Conductors	EU wire code type example	US wire code type example
24/40-3	13	4	10	3	H05VV-F-3G2.5/ H05RN-F-3G2.5	THHN, THHW
24/60-3	19	4	10	3	H05VV-F-3G2.5/ H05RN-F-3G2.5	THHN, THHW
24/80-3	18	4	10	3	H05VV-F-3G4/ H05RN-F-3G4	THHN, THHW
24/100-3	22	4	10	3	H05VV-F-3G4/ H05RN-F-3G4	THHN, THHW

For cable gland, Using the cable gland is not allowed in the US. Please Do not install it in the US. For flexible cord, using the flexible cord is not allowed in the US. Please Do not install it in the US.

Connection of AC-wiring and recommended wire colours. 230V/50Hz installations

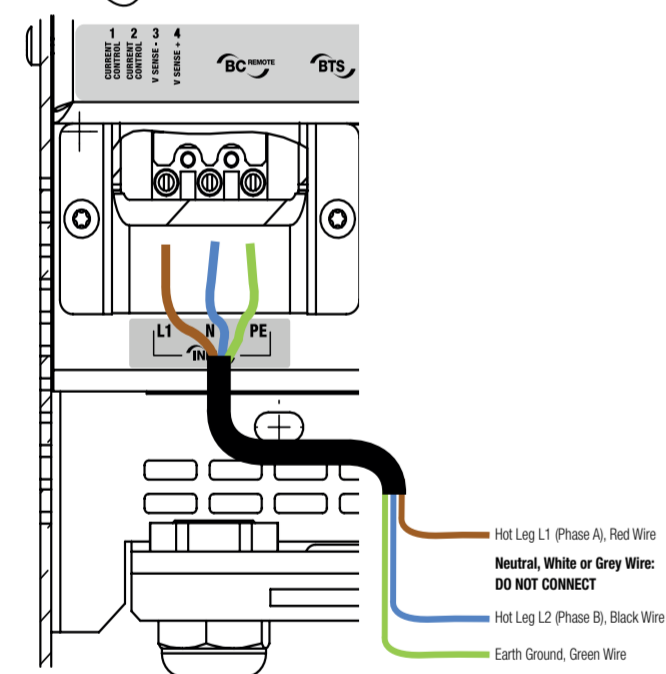
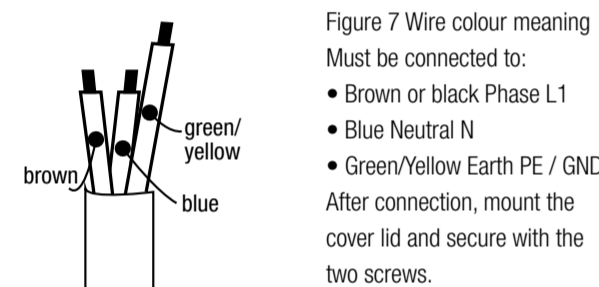

#### 4.4.2 Grounding

##### WARNING!

The ground wire only offers protection if the cabinet of the WP-BC Supreme-Pro Charger is connected to the safety ground. Connect the ground terminal (PE / GND) to the hull or the chassis.



##### CAUTION!

For safe installation it is necessary to install a Residual Current Device (earth leakage switch) in the AC input circuit of the WP-BC Supreme-Pro Charger.

#### 4.4.3 DC cables

Keep the cable connection between the charger and batteries as short as possible. If available, use coloured battery cables. If this is not possible, mark the plus and the minus cables with coloured insulating tape, e.g. red for plus and blue/black for minus.

Use the following diameters:

**Model WP-BC Supreme-Pro Charger, Length <3 m/ Length 3-6 m**

WP-BC-PRO 24/40-3, 24/60-3:  
25 mm<sup>2</sup> (AWG 3)/ 35 mm<sup>2</sup> (AWG2)

WP-BC-PRO 24/80-3, 24/100-3:  
50 mm<sup>2</sup> (AWG0)/ 70 mm<sup>2</sup> (AWG00)

Secondary battery connection (all types):  
4 mm<sup>2</sup> to 6 mm<sup>2</sup>

#### Connection of main batteries:

- 1 Pull the cables through the cable glands of the WP-BC Supreme-Pro Charger.
- 2 Crimp on the ring terminals to the cables:
  - ring M8 for 24/40-3, 24/60-3, 24/80-3 and 24/100-3.
- 3 Connect the cables to the terminals of the WP-BC Supreme-Pro Charger. Check the polarity is correct, positive on positive & negative on negative
- 4 Integrate a suitable fuse (charger fuse) in the positive cable. When using a DC distribution box with integral fuses, no additional fuse is necessary.
- 5 Cut the cables to the required length and crimp on the ring terminals. Connect the cable to the DC distribution box or batteries.



##### CAUTION!

Reversing the positive and negative battery poles will severely damage the WP-BC Supreme-Pro Charger. Undersized (cross-section too small) cables and/or loose connections can cause dangerous overheating of the cables and/or terminals. Lay the positive and negative cables next to each other to minimise the electromagnetic field around the cables. The negative cable should be connected directly to the negative post of the battery bank or the ground side of a current shunt. Do not use the hull or chassis frame as the negative conductor.

#### 4.5 Maximum charge current & battery capacity

Follow the instructions given by battery manufacturer. The minimum required battery capacity for WhisperPower gel batteries is as follows:

##### WP-BC Supreme-Pro Charger recommended battery capacities

WP-BC-PRO 24/40-3: 100Ah to 500Ah  
WP-BC-PRO 24/60-3: 150Ah to 750Ah  
WP-BC-PRO 24/80-3: 300Ah to 800Ah  
WP-BC-PRO 24/100-3: 400Ah to 1500Ah

##### Record specification of installed batteries

Battery model: AGM Power -12V 200Ah (and number of cells)  
Battery type: AGM Batteries (Absorbent-Glass-Mat Batteries)  
Battery capacity: 200Ah

#### 4.6 Battery isolation & diode splitter

If one or more main batteries or battery sets must be charged at the same time via one output, a battery isolator (combiner) should be used. This isolates the battery sets from each other to prevent one discharging the other. A consequence of the battery isolator is a typical voltage drop of 0.6 Volt. This voltage drop can be compensated in two ways:  
1 By changing DIP-switch 5 to On (Diode enable);  
2 By using the voltage sense function (see section 4.8);  
WhisperPower offers several battery isolators.



##### CAUTION!

Never use both methods. Your batteries will be overcharged and severely damaged!

For a proper installation, see also the connection diagram included with the battery isolator. Steps:

- 1 Check that the WP-BC Supreme-Pro Charger, the main supply and the DC distribution box are switched off.
- 2 Check that the DC fuses have been removed.
- 3 Connect the battery isolator(s) using cables with the same diameter as the battery cables.
- 4 Compensate the voltage drop over the battery isolator by changing the setting of dip switch 5.
- 5 Switch on the WP-BC Supreme-Pro Charger.

#### 4.7 Connecting of a secondary battery bank (6A output)

Battery charger models equipped as standard with two secondary charge outputs that can be used to give a maintenance charge to a small second battery set such as a starter or cranking battery. The maximum charge current of the second output is 6A.

- Use 4 to 6 mm<sup>2</sup> cable for connection.
- Connect the minus of the second battery to the common ground (minus) of the main battery.
- Connect the plus of the second battery to the +6A by ring M4 terminal of the WP-BC Supreme-Pro Charge, +S1 and/or +S2.
- Integrate a 10A slow acting fuse in the plus cable.

#### 4.8 Temperature sensor

The standard temperature sensor is provided with 6 m cable and a double-sided tape for easy installation. Determine the warmest place on the battery set and make it dirt and grease free. Remove the backing paper from the tape and stick the sensor on the battery. Route the cable through a cable gland and plug the modular cable into the BTS connector of the WP-BC Supreme-Pro Charger.

#### 4.9 Voltage drop compensation

To shorten the charge time substantially, the battery cable losses can be compensated by using the sense function. Use 0,75 mm<sup>2</sup>, preferably red and black wire and secure these with slow acting fuses of 2A. Connect the wires with the two upper terminals of the green connector at the left side of the cabinet. Pay careful attention to the polarity of the wires, red on +Sense(4) and black on -Sense(3). Now connect the other side of the wires: black on the minus of the battery and red on the battery side of the WP-BC Supreme-Pro Charger fuse.

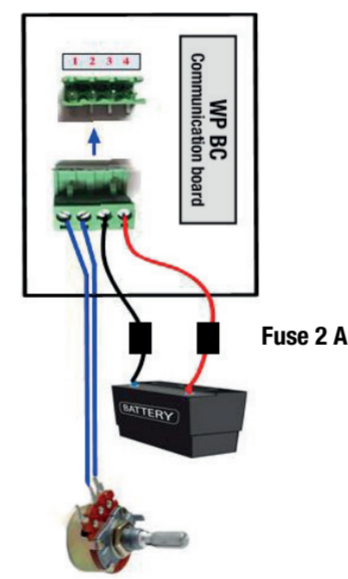

#### 4.10 Current control limitation

When permanent fixing of the maximum charge current is desired, a panel containing a linear potentiometer is required and mounted at the proper location. Use the counter-clockwise and slider contacts and wire these to connections 1 and 2 of the furthest left interface connector.

**NOTE:** The resistance value will be proportional to the percentage current output, e.g. 1k $\Omega$ = 100% and 500 $\Omega$ = 50% of rated current. A scale may therefore be provided behind the knob of the potentiometer, dividing 270 degrees into marked sections.

**NOTE:** Charger current limitation may also be set electronically e.g. BCC remote panel, but this setting is lost when power is reapplied.

#### 4.11 Status interface alarm

The battery charger is equipped with two potential free contact alarm relays. The normally-open or normally-closed contacts may be used in your system to control a generator, an appliance,

computer interface or visual indicator. Refer to 5.2 for Dip switch 6 setting that influences operation of the relays during power outage.

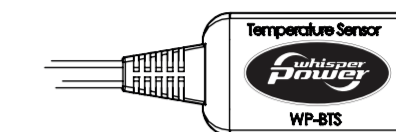
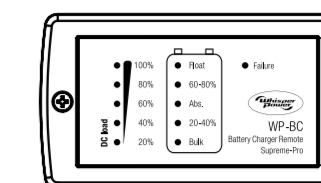
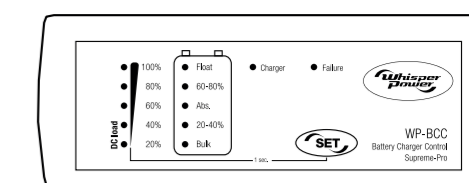
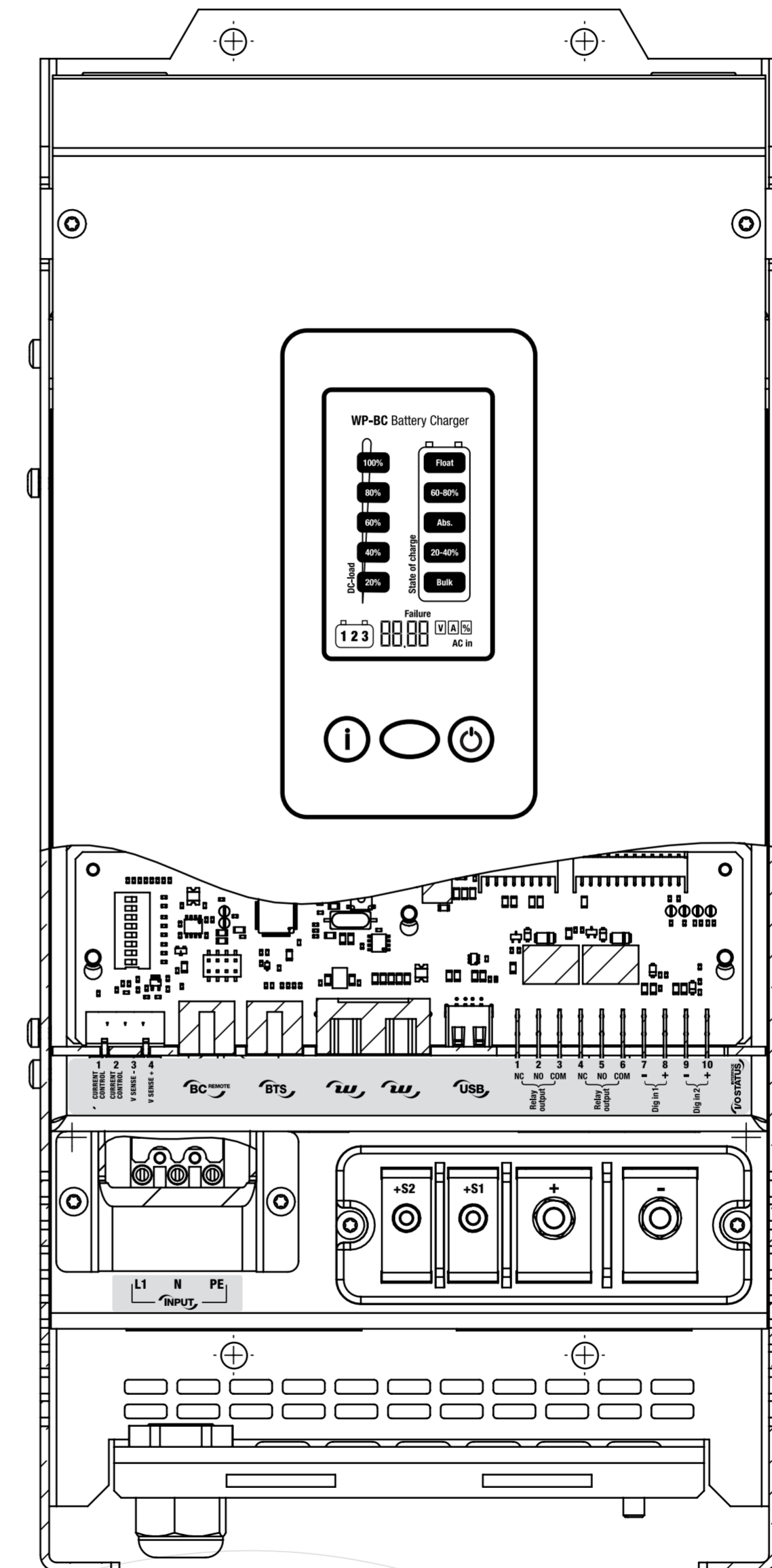
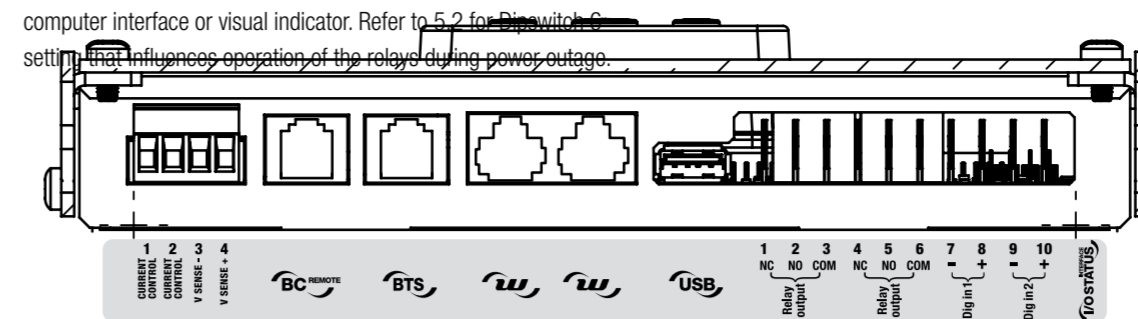

**WARNING:** Alarm relay contact ratings are designed for low current battery potentials only. Never use the relays to switch 230V AC functions.

#### 4.11.1 Relay output 1

This output reflects the ON/OFF status of the charger.

#### 4.11.2 Relay output 2

Relay 2 responds to all fault conditions that the WP-BC Supreme-Pro Charger can detect such as: AC failure, too low DC voltage, voltage sense failure, temperature sense failure.

#### 4.12 Digital Inputs

The battery charger is equipped with two digital inputs, to react to remote contact closures. Ground referenced TTL or 3V3 potentials are detected on these inputs. Please observe the polarity indicated on the marking and observe that negative (-) is at GND potential.

##### • Dig. in 1

On/off remote switch, overriding the front-panel ON switch. A closed contact (logic LO) switches the charger off.

##### • Dig. in 2

Upon applying an active LO or closed contact, the charger is switched to Forced Float constant voltage mode, regardless of the DIP switch or monitor software setting. Nominal Forced Float setting is 13.8/27.6V for 12/24V battery chargers.

#### 4.13 Connection warning

Installation work must be carried out by a licensed electrician. Before beginning with the connection of the wiring, ensure that the AC distribution as well as the DC distribution are not live.



##### CAUTION!

Short circuiting or reversing polarity may lead to serious damage to the batteries, the WP-BC SupremePro Charger, the cabling and/or the terminal connections. Fuses between the batteries and the WP-BC Supreme-Pro Charger cannot prevent damage caused by reversed polarity. The damage as a result of reverse polarity is detectable by the service department and is not covered by the warranty.

##### CAUTION!

Undersized cables and/or loose connections can cause dangerous overheating of the cables and/or terminals. Therefore, tighten all connections well, in order to limit transition resistance as far as possible. Use cables of the correct size.

**NOTE:** If the battery temperature remains within 15- 25°C, connection of the battery temperature sensor is optional.

**NOTE:** The WP-BC Supreme-Pro Charger facilitates connection of WhisperConnect CAN bus and WP-BC-PRO remote-control panels.





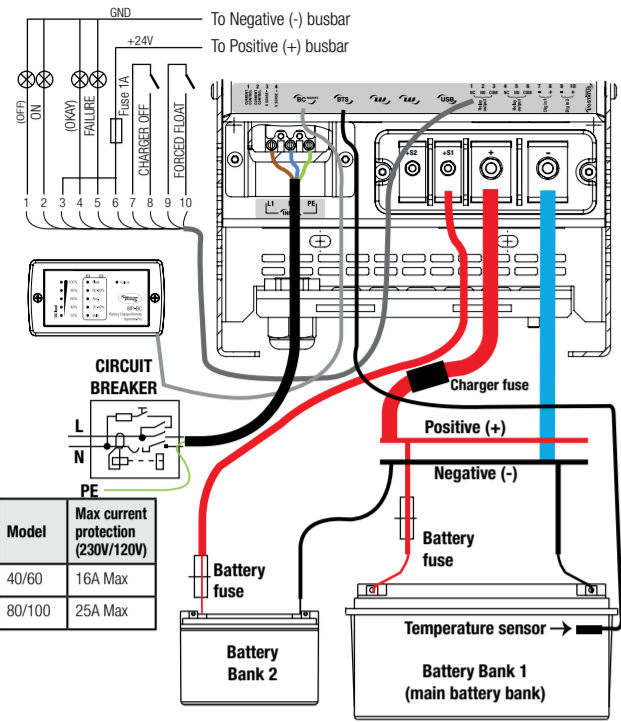

Figure 8: Installation drawing of the WP-BC Supreme-Pro Charger. This schematic is to illustrate the general placement of the WP-BC Supreme-Pro Charger in a system. It is not meant to provide detailed wiring instructions for any particular electrical installation.

Fuse table	
Model	Recommended fuse
24/40-3	ANL type 50A
24/60-3	ANL type 80A
24/80-3	ANL type 100A
24/100-3	ANL type 150A

#### 4.14 Installation requirements and tools:

- Main batteries: note type, charge voltage, individual and total capacity (Ah)
- Secondary batteries: note type, charge voltage, individual and total capacity (Ah)
- Battery fuses and fuse-holders, to be installed in positive leads
- Battery cables (obey colour codes and diameter) for main and secondary batteries
- Where appropriate, DC isolation switches with mounting requirements
- Cable shoes and appropriate crimping tool
- Torx screwdriver (TX20) for opening the charger
- Screws (not included) and tools for mounting the charger
- Mains cable (flexible 3-core, appropriate diameter) and flat screwdriver for AC connection
- Utility group with proper isolator switch or earth leakage switch
- Hex socket wrench/screwdriver (10mm and 7mm) for DC cable connections
- UTP patch cable, crimping tool and connectors for WhisperConnect and/or Alarm wiring
- Wiring diagram with connection details, to be left with client
- Firmware upgrade on USB stick (only if applicable)

#### 4.15 Commissioning after installation

If the WP-BC Supreme-Pro Charger to be installed has been used previously it is important to consider that previous users may have adjusted the settings. In if doubt, always reset the WP-BC Supreme-Pro Charger to factory settings.

##### 4.15.1 General

The factory settings of the WP-BC Supreme-Pro Charger are optimised to suit most typical installations. However, for some installations it is beneficial to adjust some settings. Several adjustments can be made. See chapter 5.

**NOTE:** The DIP-switches must be set before commissioning; all other settings can only be made after commissioning.

#### CAUTION!

Check the polarity of all wiring before commissioning: positive connected to positive (red cables), negative connected to negative (black cables). If all wiring is OK, place the DC-fuse(s) of the DC distribution box to connect the batteries to the WP-BC Supreme-Pro Charger.



#### WARNING

When placing these fuses, a spark can occur, caused by the capacitors used in the WP-BC Supreme-Pro Charger. This is particularly dangerous in places with insufficient ventilation, due to the gassing of the batteries an explosion can occur. Avoid having flammable materials close by.

Now the WP-BC Supreme-Pro Charger is ready for operation. After switching on the AC power supply the WP-BC Supreme-Pro Charger will initiate the charging process.

#### 4.15.2 WhisperConnect CAN bus (optional)

During first commissioning the WP-BC Supreme-Pro Charger will be recognized by the WhisperConnect CAN bus network automatically. The remote control panel of the WhisperConnect CAN bus network will indicate that a new device was found. Some settings can only be changed via the WhisperConnect CAN bus interface.

#### 4.16 Decommissioning

The following steps should be carried out to decommission the WP-BC Supreme-Pro Charger:

- 1 Switch the WP-BC Supreme-Pro Charger to OFF (see section 3.1.2).
- 2 Remove the DC-fuse(s) of the DC-distribution and/or disconnect the batteries.
- 3 Remove the AC-fuse(s) of the AC-input and/or disconnect the AC-mains.
- 4 Open the connection compartment of the WP-BC-PRO Charger.
- 5 Check with a suitable voltage meter that the inputs and the outputs of the WP-BC Supreme-Pro Charger are not live.
- 6 Disconnect all the wiring.
- 7 Demount the WP-BC Supreme-Pro Charger.

#### 4.17 Storage, handling and transportation

The WP-BC Supreme-Pro Charger should be stored in the original packing, in a dry and dust free environment. Always use the original packing for transportation. Contact your local WhisperPower Service Centre for further details if you want to return the apparatus for repair.

#### 4.18 Re-installation

To reinstall the WP-BC Supreme-Pro Charger, follow the instructions as described in this chapter (chapter 4).

#### 5. CONFIGURATION SETTINGS

The WP-BC Supreme-Pro Charger settings can be adjusted by means of DIP-switches.



#### CAUTION!

Invalid settings of the WP-BC Supreme-Pro Charger can cause serious damage to your batteries and/or the connected load! Adjustments of settings may be undertaken by authorised personnel only!

#### 5.1 DIP switch operation

The WP-BC Supreme-Pro Charger has eight DIP switches, see section 4.3. These switches are operated by flipping the levers to the other position, using a small screw driver.

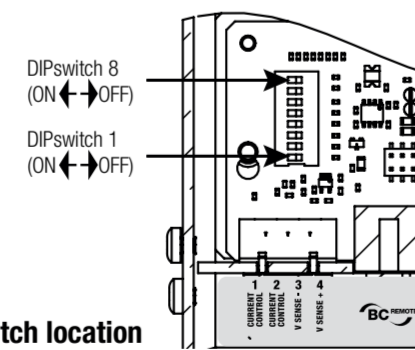

#### DIP switch location

#### 5.2 DIP switch functions

See the table at right for the functional overview of the eight DIP switches.

Dip SW	Function	Description
1	AGM/Gel mode	Contact WhisperPower for detailed voltage and timing settings
2	Traction mode	Contact WhisperPower for detailed voltage and timing settings
3	High float mode battery	Contact WhisperPower for detailed voltage and timing settings
4	User setting	Contact WhisperPower for user defined charging characteristics
5	Diode compensation mode on	Diode compensation on. Compensates the voltage drop across an externally connected diode splitter or battery isolator. Note: Either this function or sense wire connection may be used.
6	Continuous monitoring mode off	Switch ON to disable continuous monitoring, to preserve battery power. This will cause WhisperConnect, Alarms and remote panels to stop functioning during a mains failure.
7	Forced to float mode	One step charge program with fixed float voltage. (Highest priority and fixed at float voltage)
8	CAN bus termination	Switch ON for WhisperConnect bus termination at charger location

#### 5.2.1 Battery charge curves

Charge characteristic voltages are set using DIP switches 1 to 4.

- Factory setting (no DIP switch set) This is the standard setting that suits the most frequently used lead-acid batteries. Changing the charge characteristic settings to other curves must only be done after careful consideration and consulting the battery manufacturers specifications. Only one charging curve may be selected (only none or one of DIP switches 1 to 4).



**WARNING:** WhisperPower is not responsible for damage to batteries, even when factory setting is applicable.

- Gel/AGM batteries (DIP switch 1) Some gel/AGM batteries need a higher float voltage for optimal charging. Changing the float voltage can be done by setting DIP switch 1 to "ON". The float voltage will increase to 27.6V (24V charger).
- Traction setting (DIP switch 2) Setting for traction charging: +0.7V during bulk and +0.4V in absorption for 24V batteries.
- High float mode battery setting (DIP switch 3) Setting for High float mode batteries: +0.2/0.4V during bulk and 0.15/0.3V in absorption for 12/24V batteries.
- User setting (DIP switch 4) For this setting, the manufacturer shall be contacted to supply a user-defined charge characteristic. This switch shall not be set when no curve is provided.

#### 5.2.2 Option settings

- Diode setting (DIP switch 5) Setting for +0.6 V voltage compensation in case a battery isolator is used. 1 = ON; 0 = OFF
- Continuous monitor mode (DIP switch 6) WhisperConnect CAN bus, and DC-alarm stay functioning during mains failure. Remote panel stays functioning if it has its own power source.
- Force Float (DIP switch 7) For special applications a fixed charge voltage may be required. The battery charger allows you to change the three stage charge program to a single stage program by activating the function "Force Float", switching DIP switch 7 to "ON". The charge voltage will be fixed at 27.6V (24V charger). Note that the Constant Voltage charging is not temperature adjusted.
- CAN bus termination (DIP switch 8) The WhisperConnect CAN bus needs to be terminated at both sides. This is normally done using a CAN bus Terminator plug, but may optionally be implemented by setting DIP switch 8 to ON.

#### 6. WHISPERCONNECT CAN BUS

##### 6.1 What is WhisperConnect CAN bus?

All devices that are suitable for WhisperConnect CAN bus are marked by the WhisperConnect CAN bus symbol. WhisperConnect CAN bus is a fully decentralised data network for communication between the different WhisperPower system devices. It is CAN bus based which has proven itself as a reliable bus-system in automotive applications. WhisperConnect CAN bus is used as a power management system for all connected devices, such as the inverter, battery charger, generator and many more.

This enables communication between the connected devices, for instance to start the generator when the battery state of charge is low. WhisperConnect CAN bus reduces the complexity of electrical systems by using UTP patch cables. All system components are simply chained together. Therefore, each device is equipped with two WhisperConnect CAN bus data ports. As only a few WhisperConnect CAN bus cables are needed, installation and material costs are reduced significantly.

New devices can be added to the existing network easily. Consequently, the WhisperConnect CAN bus network is highly flexible for extended system configuration. WhisperPower also offers several interfaces such as the NMEA2000 interface, making even non-WhisperConnect CAN bus devices suitable to operate in the WhisperConnect CAN bus network.



#### CAUTION!

Never connect a non-WhisperConnect CAN bus device to the WhisperConnect CAN bus network directly! This will void the warranty of all WhisperConnect CAN bus connected devices.



#### 6.2 How to set up a WhisperConnect CAN bus Network

Every WhisperConnect CAN bus device is equipped with two data ports. When two or more devices are connected via these ports, a local data network called Segment on the WhisperConnect CAN bus is formed. Keep the following rules in mind: Place a terminating device on both network ends. Connections between the devices are made by standard straight UTP patch cables. For central monitoring and control, one of the WP-Touch series of remote panels is required. Contact your installer or go to [www.whisperpower.com](http://www.whisperpower.com) for details of the available panels.

#### 7. EC DECLARATION OF CONFORMITY

Manufacturer: WhisperPower BV • Address: Kelvinlaan 82 9207 JB Drachten, The Netherlands  
Hereby WhisperPower declares under our responsibility that  
**Product:** WP-BC-PRO battery charger  
**Model:** WP-BC-PRO 24/40-3 - 24/60-3, WP-BC-PRO 24/80-3 - 24/100-3 is in conformity with the provisions of the following EC directives:

#### 2014/35/EU (LVD Directive); the following harmonised standards have been applied:

EN 62368-1: 2014/A11:2017 Safety requirements of Audio/video, information and communication technology equipment  
EN 60335-1:2012+A11 General Safety requirements of Household and similar electrical appliances:  
EN 60335-2-29:2004+A2: 2010 Particular Safety requirements for battery chargers  
EN 62233:2008 Measurement methods for electromagnetic fields of household appliances and similar apparatus with regard to human exposure

#### 2014/30/EU (EMC Directive); the following harmonised standards have been applied:

EN 55032: 2015 Electromagnetic compatibility of multimedia equipment - Emission Requirements  
EN 55014-1: 2017 Emission Requirements for household appliances, electric tools and similar apparatus  
EN 61000-6-2: 2005 Generic standards - Immunity for industrial environments  
EN 61000-3-2: 2014 Limits for harmonic current emissions (equipment input current ≤ 16 A per phase)  
EN 61000-3-3: 2013 Limits - Limitation of voltage changes, voltage fluctuations and flicker in public low-voltage supply systems, for equipment with rated current ≤ 16 A per phase and not subject to conditional connection  
EN 61000-4-11: 2004 Testing and measurement techniques - Voltage dips, short interruptions and voltage variations immunity tests

#### UL

UL1236 Battery Chargers for Charging Engine- Starter Batteries

#### cUL

CSA C22.2 No. 107.2 Battery Chargers

M.B. Favot WhisperPower Product Manager  
Drachten, 13 November 2018

#### 8. TROUBLE SHOOTING & FAULT FINDING

In the case of a fault, the WP-BC Supreme-Pro Charger display shows an error code to help you find its source. If you cannot solve a problem with the aid of the fault finding table, contact your local WhisperPower Service Centre. See [www.whisperpower.com](http://www.whisperpower.com). Make sure you have a record of the article and serial number of the installed device(s) (See section 1.4).

##### 8.1 Fault finding table

FAULT	POSSIBLE CAUSE	RECOMMENDED ACTION
No output voltage and/or current	No AC-input.	Check AC wiring, check remote control panel.
	AC-input voltage too low (< 180VAC). AC input frequency out of range.	Check input voltage, check generator. Check input voltage, check generator.
Output voltage too low, charger supplies maximum current	Load that is connected to the batteries is larger than charger can supply.	Reduce load taken from the batteries.
	Batteries not 100% charged.	Measure battery voltage. After some time this will be higher.
Charge current too low	Batteries almost fully charged.	Nothing, this is normal when the battery is almost fully charged.
	High ambient temperature. Low AC input voltage. At lower AC-input voltages the charge current is reduced.	Nothing; if ambient temperature is more than 40°C the charge current is automatically reduced. Check AC-input voltage.
Batteries not fully charged	Charge current too low.	See "Charge current too low".
	Current supplied to DC load is too high.	Reduce load taken from the batteries.
	Charge time too long. Battery temperature too low. Defective or old battery.	Use a battery charger with higher capacity. Use the battery temperature sensor. Check battery and replace if necessary.
Batteries are discharged too fast	Battery capacity reduced due to wastage or sulphation, stagnation.	Charge and recharge a few times, this might help. Check battery and replace if necessary.
	Defective battery (short circuit in cell).	Check battery and replace if necessary.
Batteries are too warm, gassing	Battery temperature too high.	Use the battery temperature sensor.
	Charge voltage too high.	Check settings (see chapter 5).

#### 9. TECHNICAL SPECIFICATION

Art. nr.	WP-BC SUPREME-PRO		WP-BC SUPREME-PRO	
	24/40-3	24/60-3	24/80-3	24/100-3
60205440	60205460	60205480	60205401	
<b>GENERAL SPECIFICATIONS</b>				
Nominal input voltage	120/230V	120/230V	120/230V	120/230V
Nominal input frequency	50/60Hz	50/60Hz	50/60Hz	50/60Hz
Nominal output voltage	24V	24V	24V	24V
Total charge current	40A @ 28.8V @ 120Vac 40A @ 28.8V @ 230Vac	45A @ 28.8V @ 120Vac 60A @ 28.8V @ 230Vac	44A @ 28.8V @ 120Vac 80A @ 28.8V @ 230Vac	55A @ 28.8V @ 120Vac 100A @ 28.8V @ 230Vac
Number of battery outlets	3	3	3	3
Charge current +S1	6A, ±1A	6A, ±1A	6A, ±1A	6A, ±1A
Charge current +S2	6A, ±1A	6A, ±1A	6A, ±1A	6A, ±1A
Charge characteristic	I <sub>U</sub> Lo, automatic / 3-step for GEL/AGM/wet/lead acid batteries			
Charge voltage Bulk (25°C)	28.8V	28.8V	28.8V	28.8V
Charge voltage Absorption (25°C)	28.5V	28.5V	28.5V	28.5V
Charge voltage Float (25°C)	26.5V	26.5V	26.5V	26.5V
Forced Float (CV)	27.6V	27.6V	27.6V	27.6V
Max. Absorption time	4 hours	4 hours	4 hours	4 hours
Max. Bulk time (start @ 13.25/26.5V)	8 hours	8 hours	8 hours	8 hours
Min. Absorption time	15 min.	15 min.	15 min.	15 min.
Return-to-Bulk voltage (25°C)	25.6	25.6	25.6	25.6
Return Amps	6% of I <sub>max</sub>	6% of I <sub>max</sub>	6% of I <sub>max</sub>	6% of I <sub>max</sub>
Enclosure type & dimensions (hwxwx d in mm)	445 x 210 x 145	445 x 210 x 145	445 x 210 x 145	445 x 210 x 145
Enclosure type & dimensions (hwxwx d in inch)	17,5 x 8,2 x 5,7	17,5 x 8,2 x 5,7	17,5 x 8,2 x 5,7	17,5 x 8,2 x 5,7
Weight	6.3 kg /13.89 lbs	6.3 kg /13.89 lbs	6.6 kg /14.55 lbs	6.6 kg /14.55 lbs
Battery capacity (recommendation)	100-500Ah	150-750Ah	300-800Ah	400-1500Ah
<b>TECHNICAL SPECIFICATIONS</b>				
Power factor (cos phi)	>_ 0.97	>_ 0.97	>_ 0.97	>_ 0.97
Full load consumption (230VAC)	1400VA	2000VA	2700VA	3375VA
Temperature compensation	battery temperature sensor with 6 meter cable included			
Voltage compensation	yes, automatic	yes, automatic	yes, automatic	yes, automatic
DC consumption with connected battery	< 5 mA (DipSwitch 6 = ON)			
Display	unit has a display for charge/voltage and charge indication			
Temperature range	-25 to +60°C / -13 to 140°F, maximum temperature is 40°C at 100% output current, above 40°C-60 °C, maximum output current is 50% load at 60 °C, below 0 °C, maximum output current is 10% load.			
Cooling	vario fan and natural cooling to ensure optimized cooling			
Sound level (40% load @ 40°C)	< 55dBA @ 1 m	< 55dBA @ 1 m	< 55dBA @ 1 m	< 55dBA @ 1 m
Protection degree	IP23	IP23	IP23	IP23
Approvals	fully CE according to LVD Directive 2014/35/EU and EMC directive 2014/30/EU			

#### Assembly parts list

##### 1. Provided parts

DESCRIPTION	TYPE	ORDER CODE	
WP-BC Supreme Pro	see ID label	see ID label	
WP-BC Remote Control	RS232 on RJ11	61112307	with 6m cable
WP - Battery Temperature Sensor	BTS	60201202	with 6m cable

##### 2. Optional parts (accessories)

DESCRIPTION	TYPE	ORDER CODE	
WP-BCC Battery Charger Control Remote Panel	RS232 on RJ11	61112301	
WP Touch Panel Screen full color 5 Inch		40280100	
WP Touch Panel Screen full color 7 Inch		40280101	
WP Touch Panel Screen full color 9,7 (10) Inch		40280102	
WhisperConnect RJ45 CAN Terminator		40290350	