

DATASHEET	
INPUT VOLTAGE	12-24Vdc
POWER RATING	44,7 W
MAX INPUT CURRENT	3,8 A (12V) - 1,75 A (24V)
VOLUME	30 L
REFRIGERANT	R600a
CHARGE	14g
CLIMATIC CLASS	T
WEIGHT	14 kg

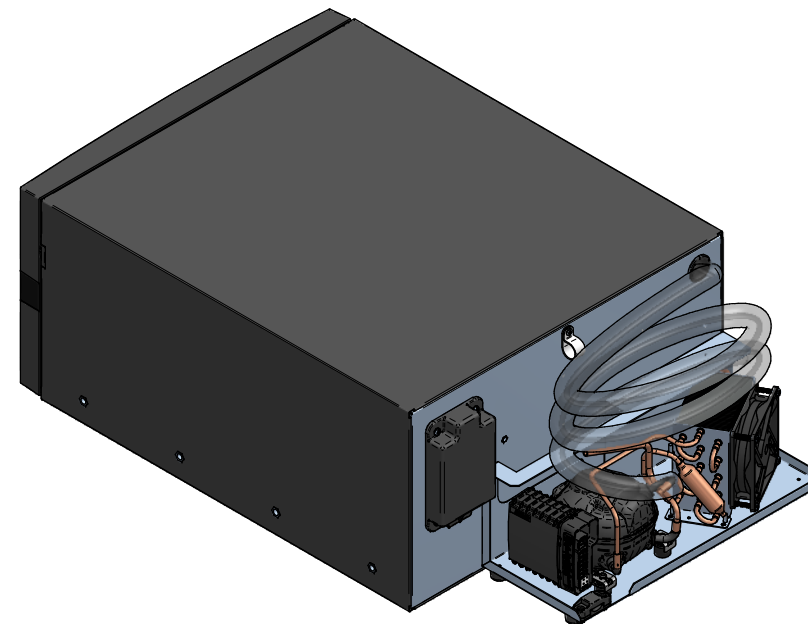
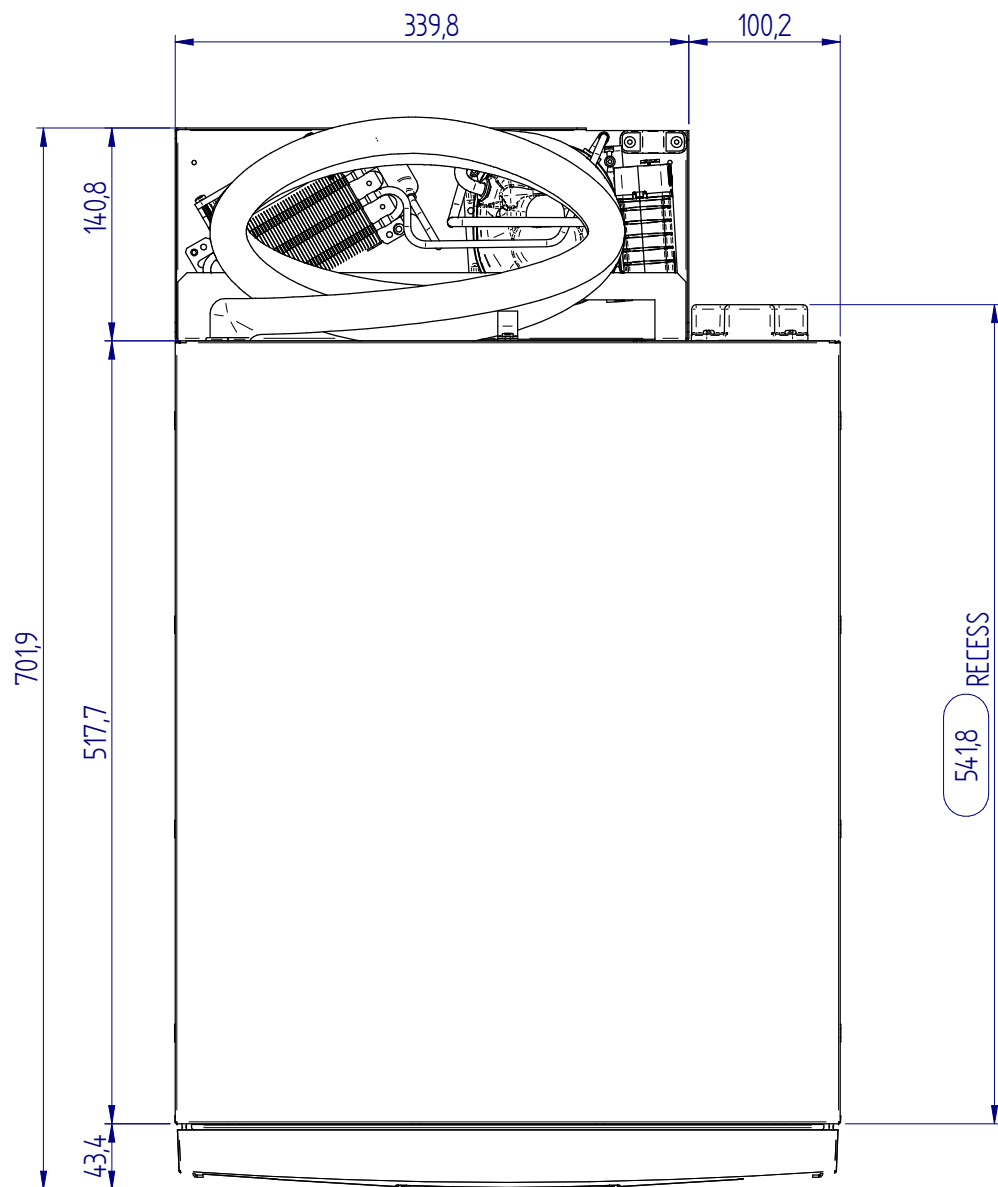

CONDENSING UNIT
(remotable up to 1,5m)

RIPRODUZIONE E/O DIFFUSIONE VIETATA	REV.	DATA	DESCRIZIONE REVISIONE				DISEGNATO	APPROVATO	VITRIFRIGO COOLAND BEYOND				
	DISEGNATO	RICCI A.	APPROVATO	COTI C.	DATA	24/07/2025	SCALA	15		PESO	14 kg	TOLLERANZE GENERALI	
	MATERIALE	UNI EN ISO 22768 - mK TUBAZIONI: ±1mm CAVI: -2mm; +10mm											
	RIVESTIMENTO SUPERFICIALE	-											
	DENOMINAZIONE	D30A DC NERO BDN-R6 *FRY*							TAV.	1 Di 2		0402-0409	

14	9601R0273.K	R-TASTIERA A MEMBRANA D20/30(KPT)+ SEDE
13	9601-0026	TASTIERA A MEMBRANA D20A/D30A
12	9210-0701	BASE MOTORE UNITA' REMOTA SLIM90
11	7901-0016	SCHEDA ELETTR. CONTROLLO SERIE VF/TL
10	7102-0041	VENT.ASS.12V COSTECH D09A04LWSZQ19
9	7054-0016	CENTRALINA SECOP BDN50K 12/24V
8	7000-0496	COMPR. SECOP BDN50K R600A 12/24V
7	5000-0119	CASSA COIBENTATA D30A *FRY*
6	4999-0055	COPPIA GUIDA SHD48400 45X400 ZN - 45KG
5	4901-0194	SEDE TASTIERA A MEMBRANA D20/30A MAR NEW
4	4901-0083	FRONTALE COMPLETO D20/30A
3	4901-0076	COPERCHIO SCHEDA ELETTRONICA D20/30A
2	4901-0074	CASSETTO D30A
1	4100-0527	COND. 14T 5T-3R-PACCO 95-PA=2,1 *CH*
N°	Codice	Descrizione

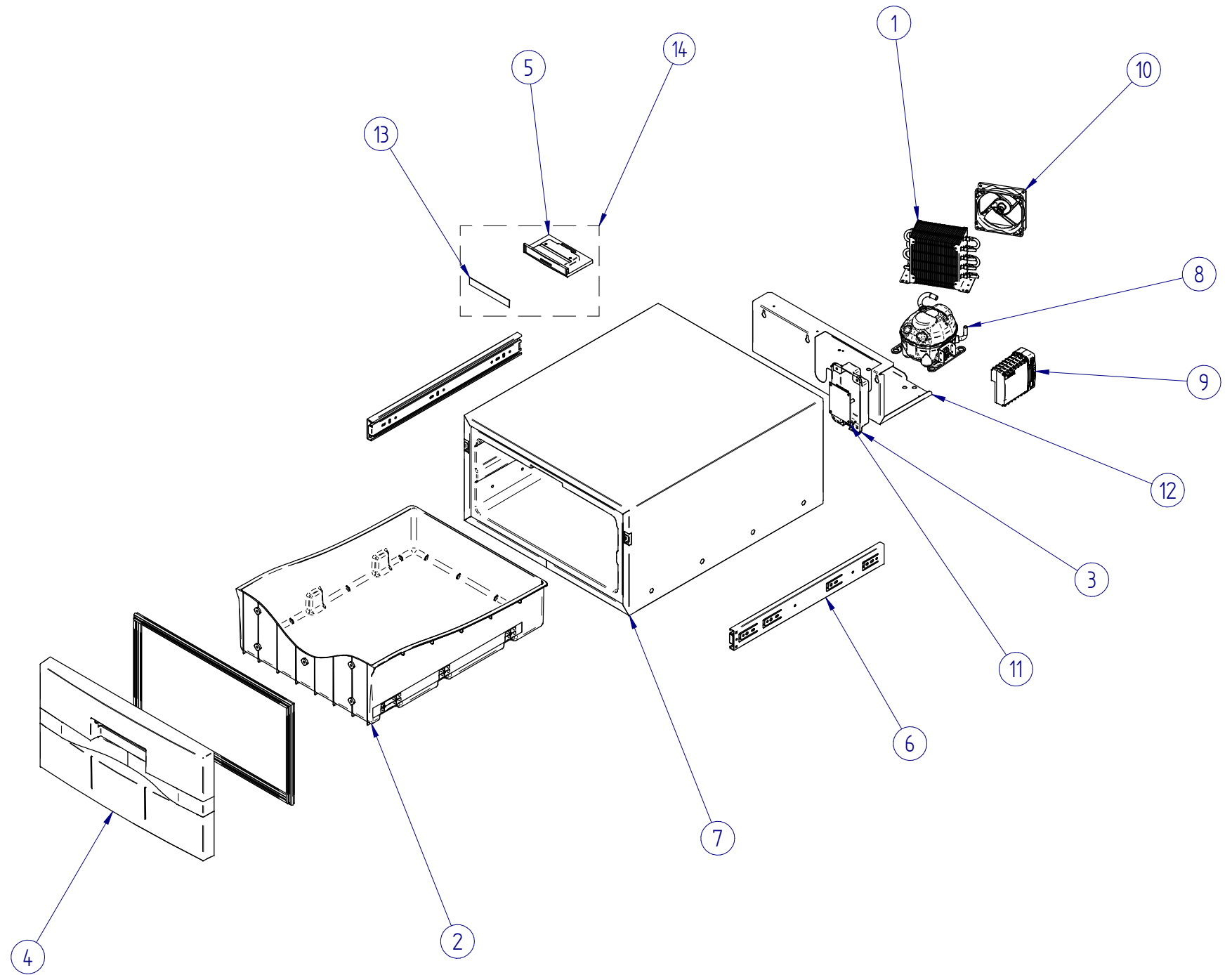

RIPRODUZIONE E/O DIFFUSIONE VIETATA	REV.	DATA	DESCRIZIONE REVISIONE				DISEGNATO	APPROVATO	VITRIFRIGO COOL AND BEYOND
	DISEGNATO	APPROVATO	DATA	SCALA	PESO	TOLLERANZE GENERALI		A3	
	MATERIALE					UNI EN ISO 22768 - mK			
	RIVESTIMENTO SUPERFICIALE	-				TUBAZIONI: ±1mm			
	DENOMINAZIONE	D30A DC NERO BDN-R6 *FRY*					TAV.	0402-0409	
						2 di 2			