

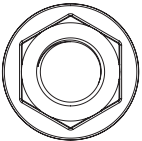

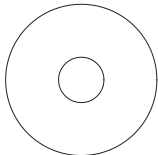

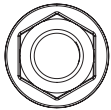
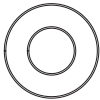
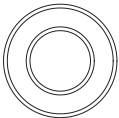
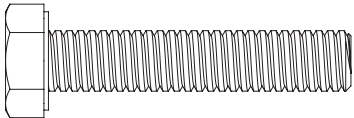
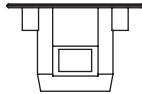
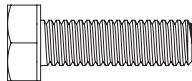
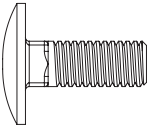

## IN8099

## ULTI Bars - X2

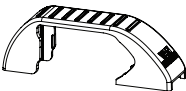
<b>FX4011 X8</b> (M8)	<b>FX4014 X8</b> (RUBBER)	<b>FX4016 X8</b> (M6)	<b>FX4017 X8</b> (M6)	<b>FX4020 X8</b> (M8)	<b>FX4024 X8</b> (M8X40)	<b>FX4025 X8</b> (M6)	<b>FX4026 X8</b> (M6X20)	<b>FX4042 X8</b> (M6)
								
<b>MA6021 X8</b>	<b>MA6065 X4</b>	<b>ME0064 X2</b>	<b>ME0065 X1</b>	<b>ME0066 X1</b>	<b>ME0203 X4</b>	<b>ME0759 X4</b>	<b>AS3192 X2</b>	
								

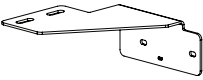
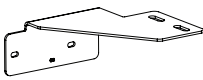
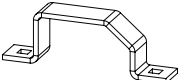
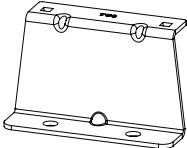
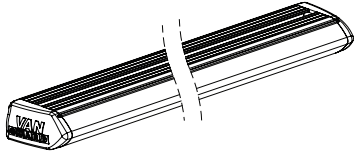
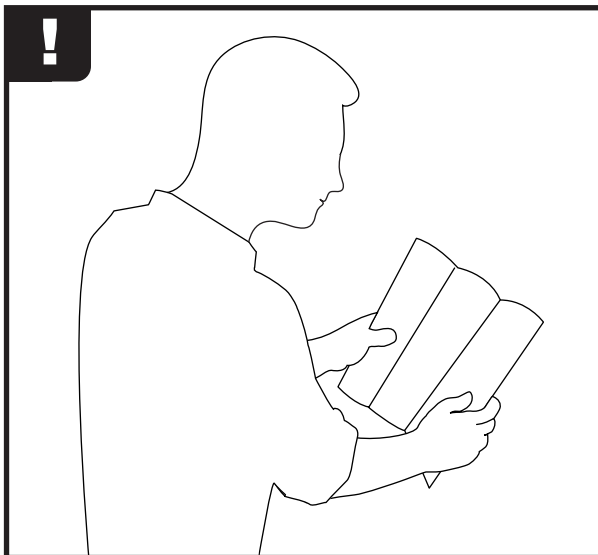
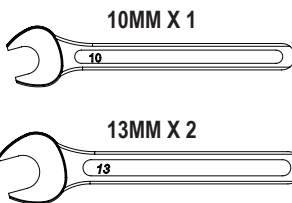
### TOOLS REQUIRED



 **GB.** Maximum load per roof bar = 55kg. Maximum load is in accordance with the vehicle manufacturer's load bearing capacity (refer to the vehicle handbook). **Do not exceed this limit.**

 **FR.** Poids maximum par barre de toit = 55kg. La charge maximale doit être conforme à la capacité de charge du constructeur de véhicule (veuillez- vous référer au livret du véhicule). **Ne dépassez pas cette limite.**

 **DE.** Maximallast pro Dachträger = 55kg. Die Maximallast steht im Einklang mit der angegebenen Ladekapazität des Fahrzeugherstellers (diese finden Sie im Fahrzeughandbuch). **Die Maximallast darf nicht überschritten werden.**

 **DK.** Maksimum last pr tagbøjle = 55kg. Maksimal lasteevne afhænger af varevognproducents angivelser i varevognens håndbog. **Overskrid ikke denne grænse.**

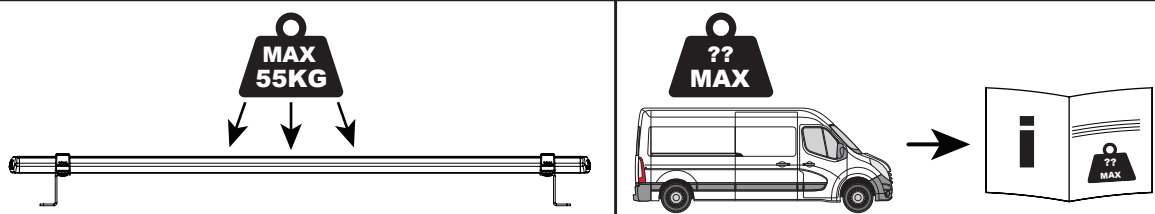

This FITTING INSTRUCTION is the property of VAN GUARD ACCESSORIES LTD. and must not be used for manufacturing purposes, copied nor communicated in any way to third parties without written permission from VAN GUARD ACCESSORIES LTD.  
IN8099\_C - 06/11/2017

Van Guard Accessories Ltd  
Fair Oak Close, Exeter Airport Business Park,  
Exeter, Devon, EX5 2UL  
www.van-guard.co.uk

## VG286-2

### Vehicle:

Renault Master: 2010 on  
Nissan NV400: 2010 on  
Vauxhall Movano: 2010 on

**Wheel Base:** SWB (L1)

**Roof Height:** Low (H1)

**Rear Doors:** Twin

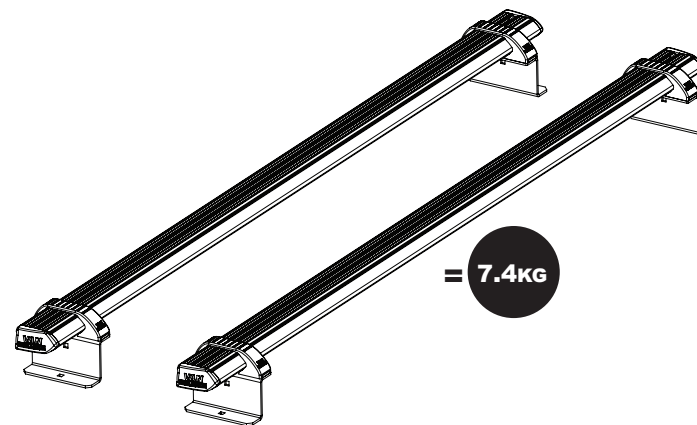
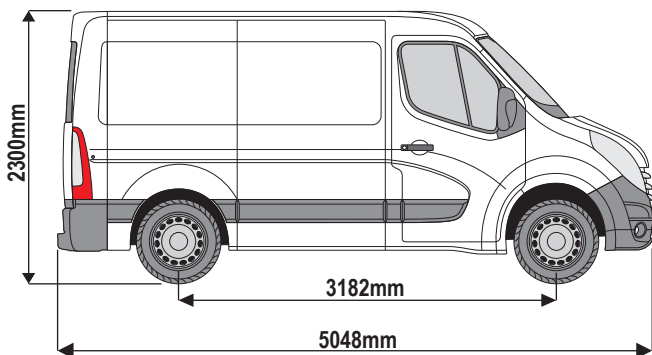

## VG286-2

### Vehicle:

Renault Master: 2010 on  
Nissan NV400: 2010 on  
Vauxhall Movano: 2010 on

**Wheel Base:** SWB (L1)

**Roof Height:** Medium (H2)

**Rear Doors:** Twin

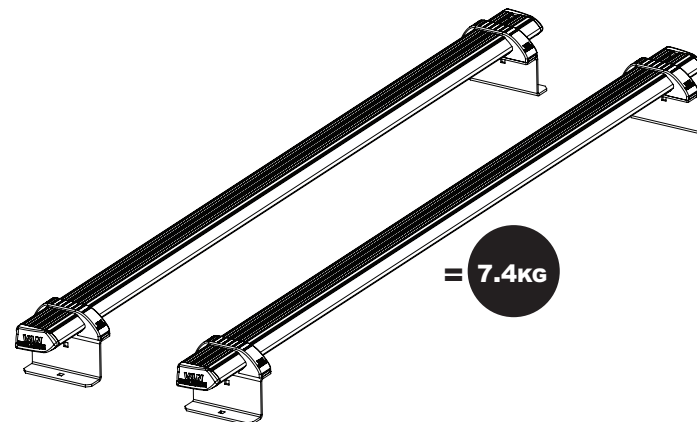
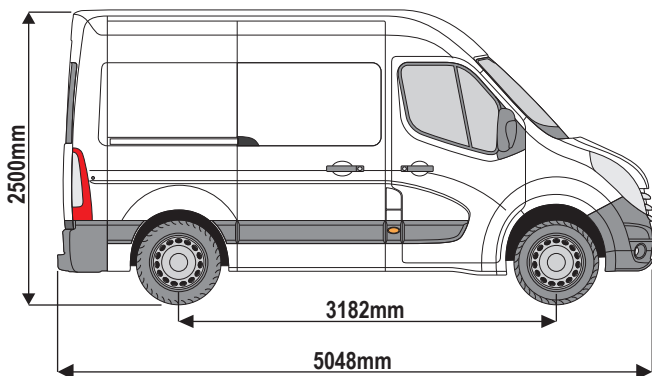

## VG286-2

### Vehicle:

Renault Master: 2010 on  
Nissan NV400: 2010 on  
Vauxhall Movano: 2010 on

**Wheel Base:** MWB (L2)

**Roof Height:** Medium (H2)

**Rear Doors:** Twin

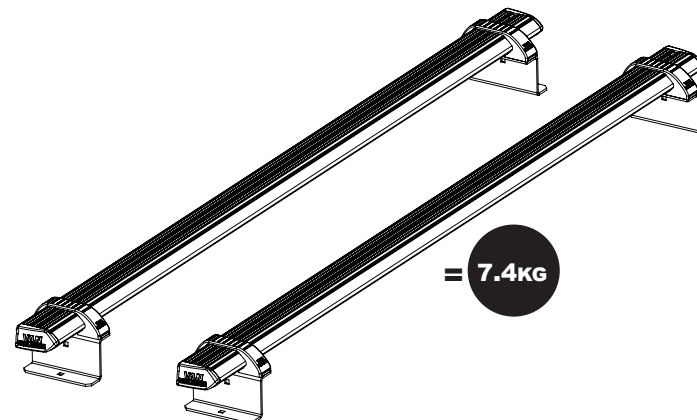
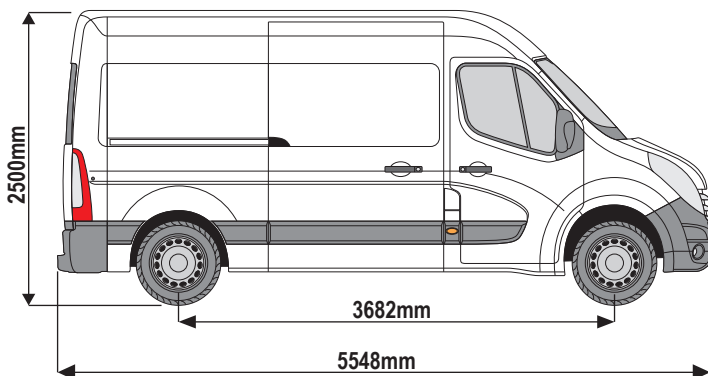

## VG286-2

### Vehicle:

Renault Master: 2010 on

Nissan NV400: 2010 on

Vauxhall Movano: 2010 on

**Wheel Base:** LWB (L3)

**Roof Height:** Medium (H2)

**Rear Doors:** Twin

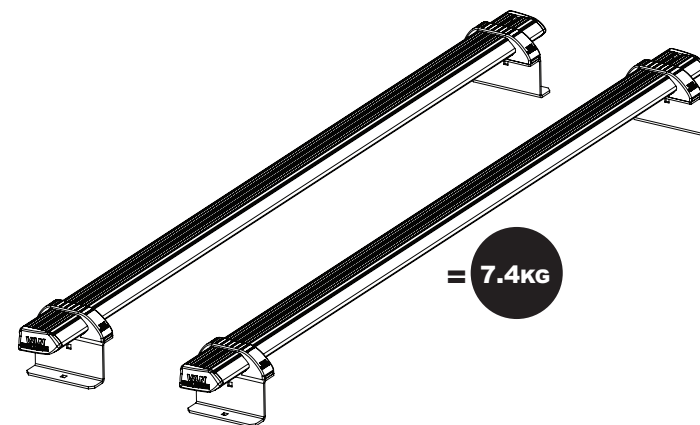
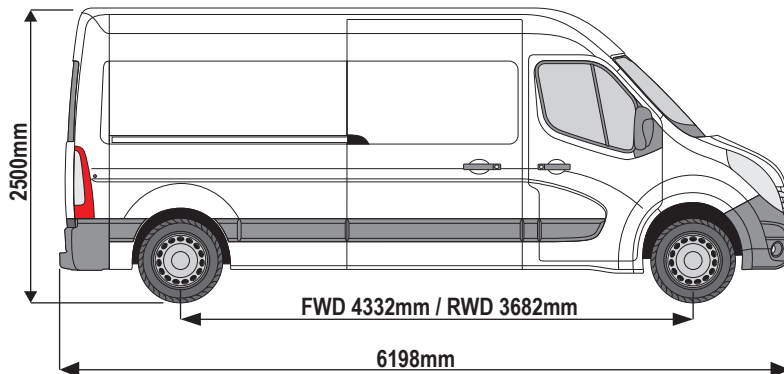

## VG286-2

### Vehicle:

Renault Master: 2010 on

Nissan NV400: 2010 on

Vauxhall Movano: 2010 on

**Wheel Base:** XLWB (L4)

**Roof Height:** Medium (H2)

**Rear Doors:** Twin

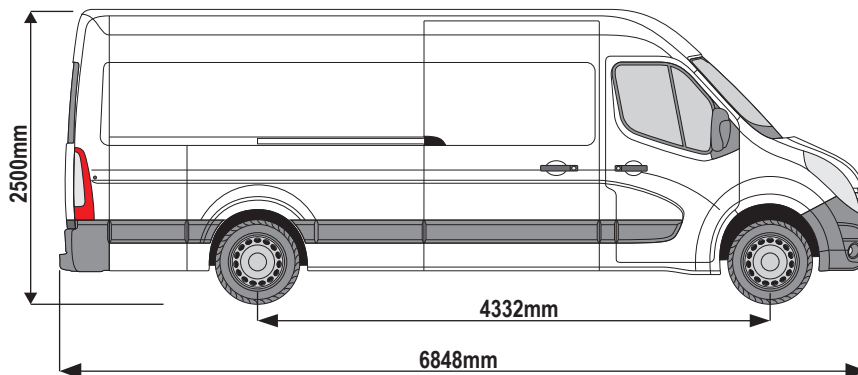

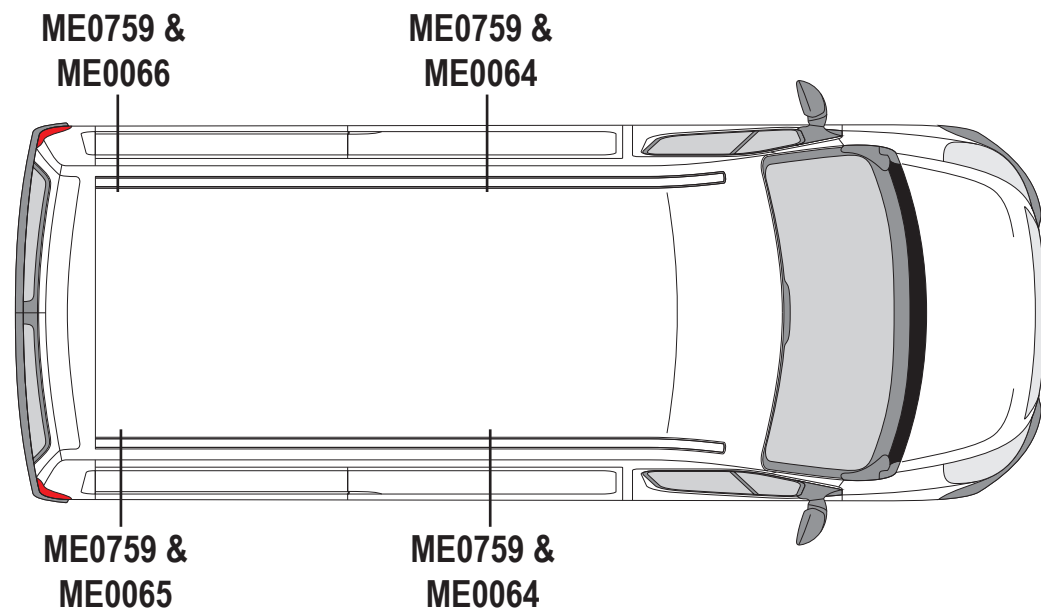
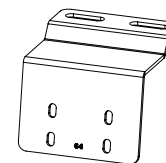
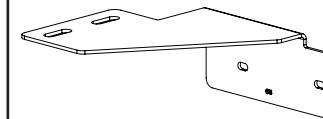
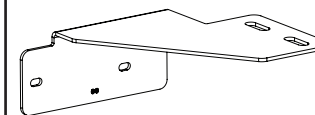
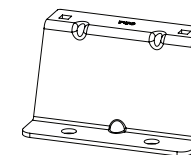
**1****ME0064****ME0065****ME0066****ME0759****2**

Remove roof plugs to reveal the vehicles fixing points.

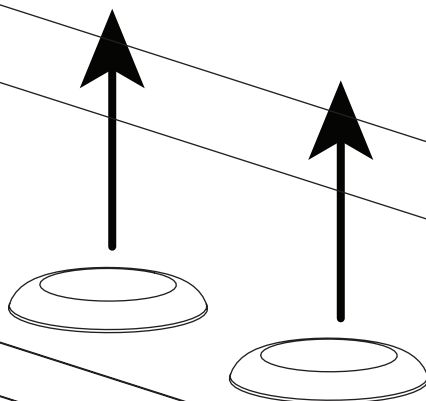
**3**

Stick rubber pads to all roof brackets.

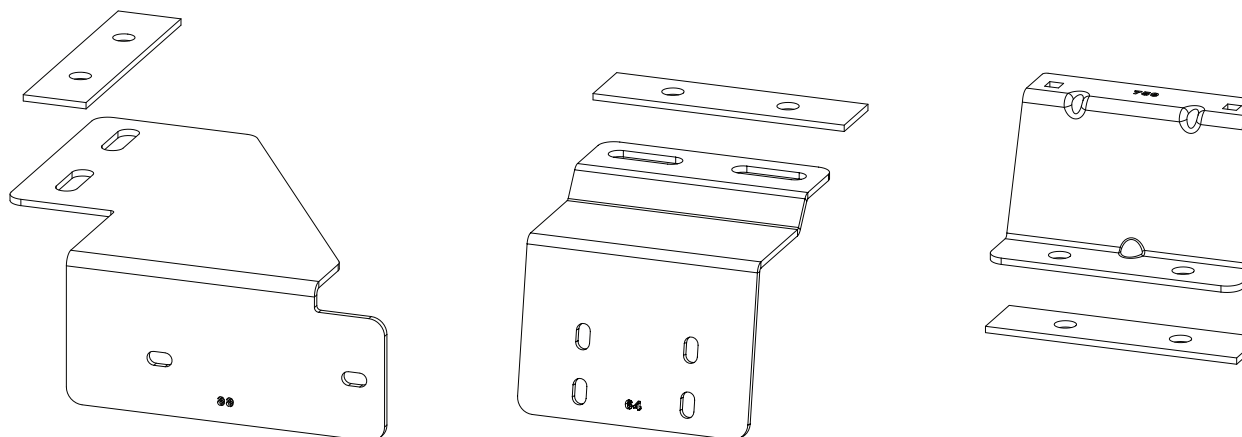

**4**

Loosely secure the middle inner fixing brackets to the inside of the vehicle by inserting the M6 1/4 turn nut inserts (FX4025) into the positions shown in FIG.1. Then place the middle inner bracket into place and loosely bolt into the M6 1/4 turn inserts using M6x20 hex bolts and M6 washers. Please note the cable trim (shown in FIG.2) may have to be removed. This trim can be refitted after the inner bracket has been secured.

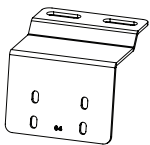
**MIDDLE (ME0064)**

MIDDLE / ME0064

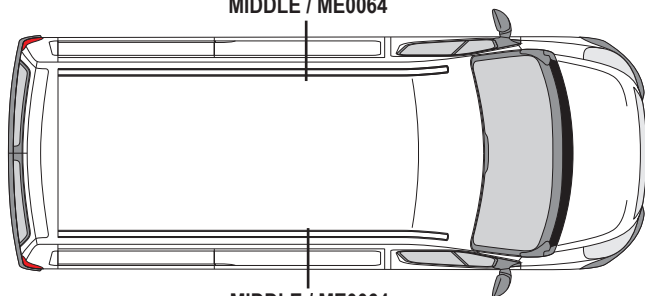

MIDDLE / ME0064

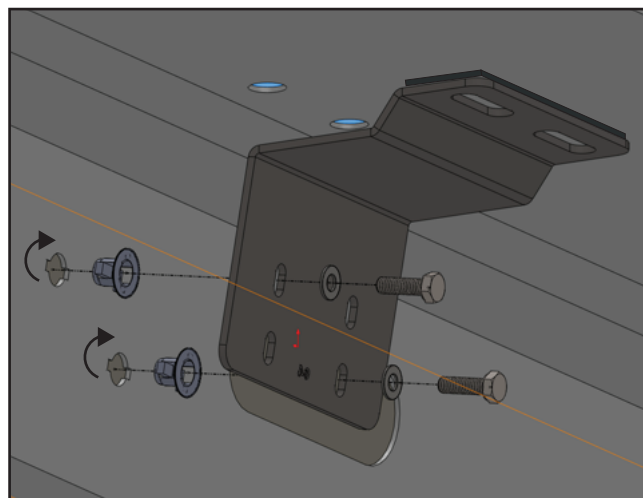
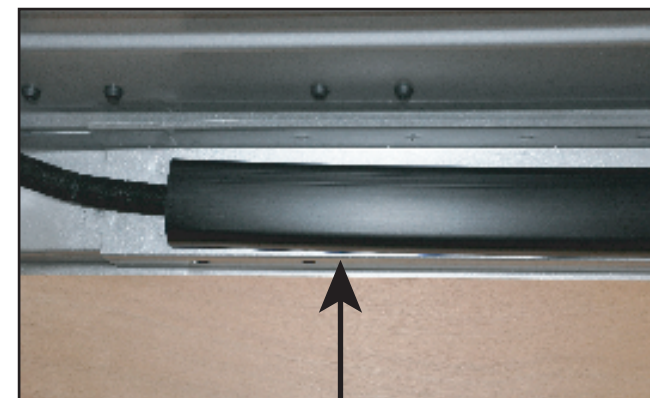
**FIG.1****FIG.2**

TRIM MAY NEED REMOVING BEFORE FITTING. THIS CAN BE RE-FITTED AFTWARDS.

**5**

Loosely secure the rear inner fixing brackets to the inside of the vehicle by inserting the M6 1/4 turn nut inserts (FX4025) into the positions shown below. Then place the rear inner bracket in position and loosely bolt into the M6 1/4 turn inserts using M6x20 hex bolts and M6 washers.

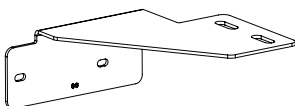
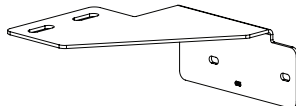
**LEFT (ME0066)****RIGHT (ME0065)**

LEFT / ME0066

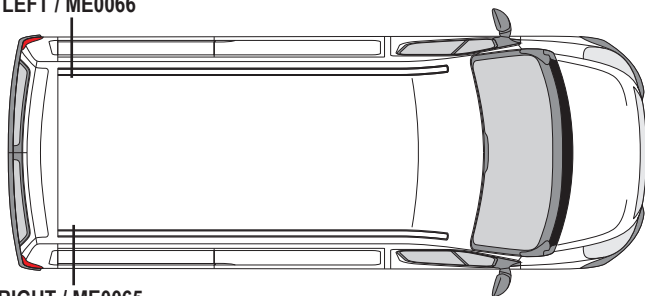

RIGHT / ME0065



M6 1/4 TURN NUT INSERT LOCATIONS

M6 1/4 TURN NUT INSERT LOCATIONS

**6** Place the roof brackets onto the roof and bolt down through the fixing points and through the inner fixing brackets using M8X40 hex bolts, M8 washers & rubber washers.

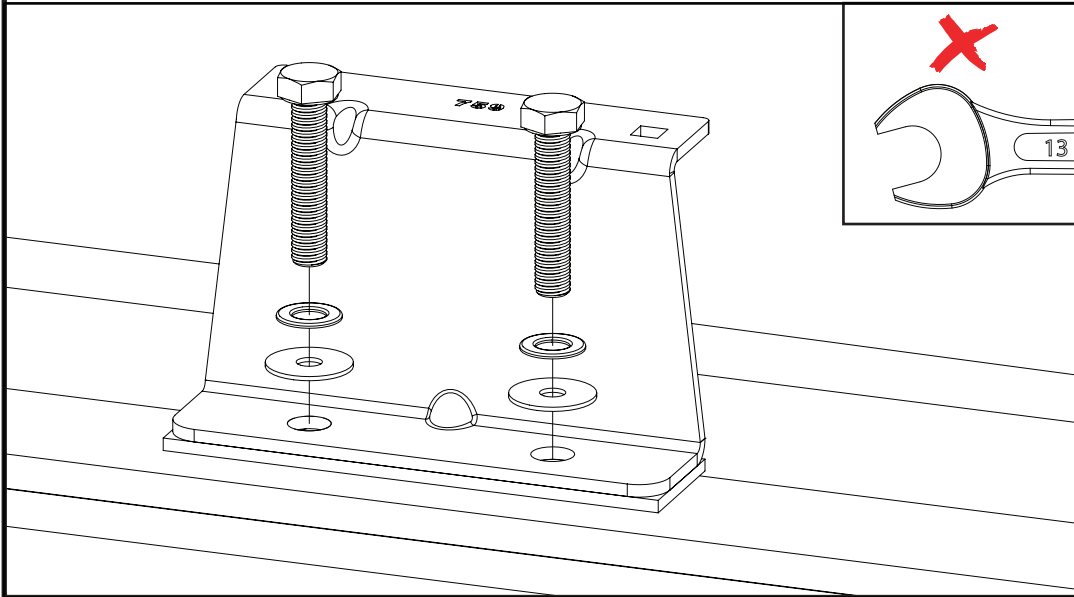

**7** Place the roof bars onto the roof brackets and loosely secure using M6X16 coach bolts & M6 flange nuts.

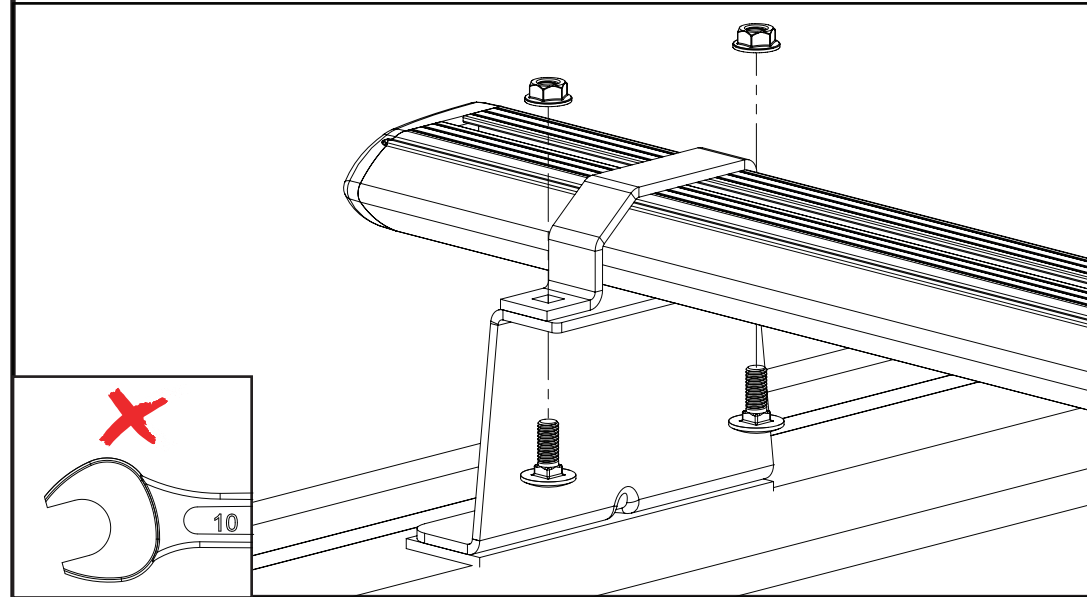

**8** Adjust the roof bars to ensure that they are evenly spaced on the vehicle.

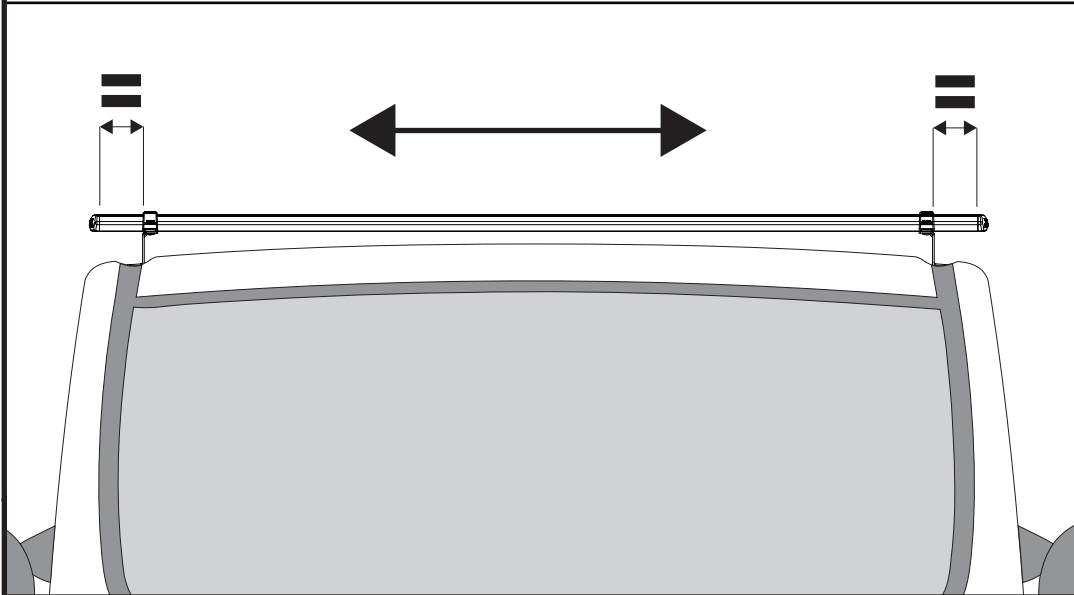

**9** Tighten the roof bar fixings to 8Nm.

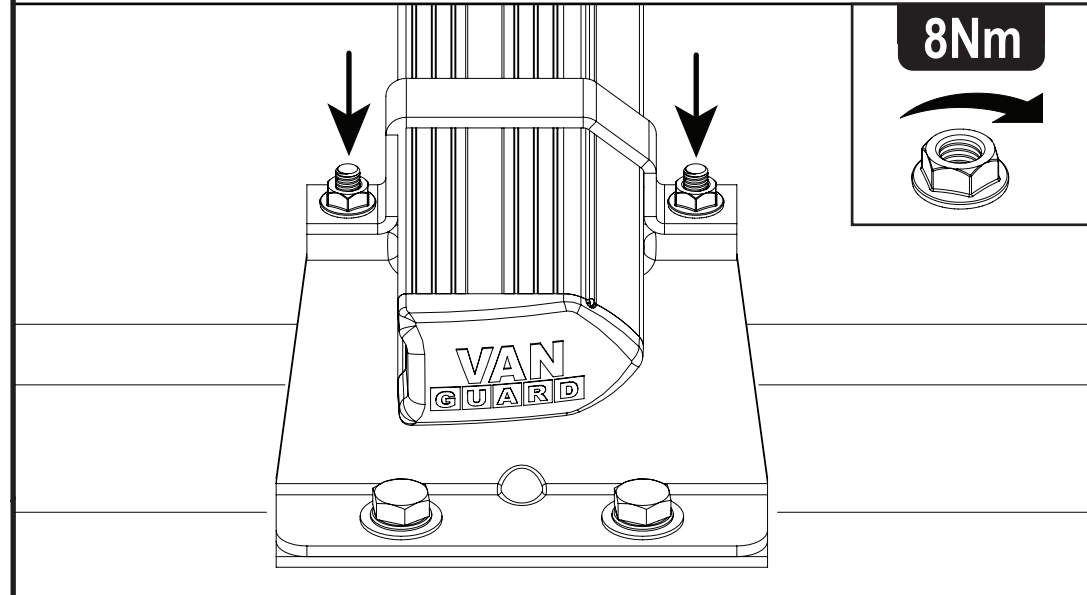

**10** Secure the roof brackets to the inner fixing brackets using M8 flange nuts and tighten to 12Nm.

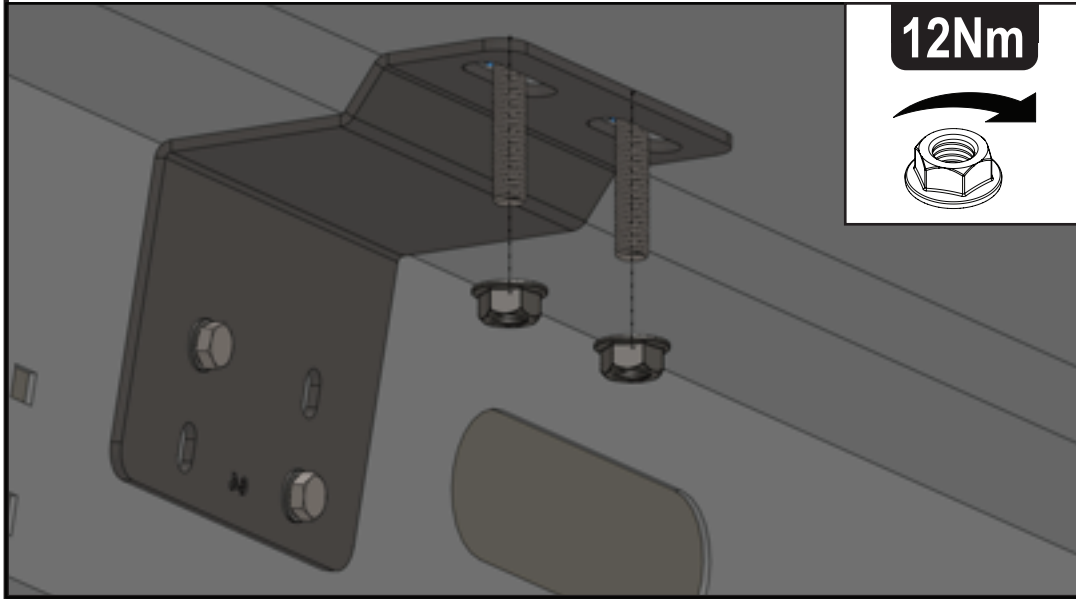

**11** Tighten the M6 fixings on all inner fixing brackets to 8Nm.

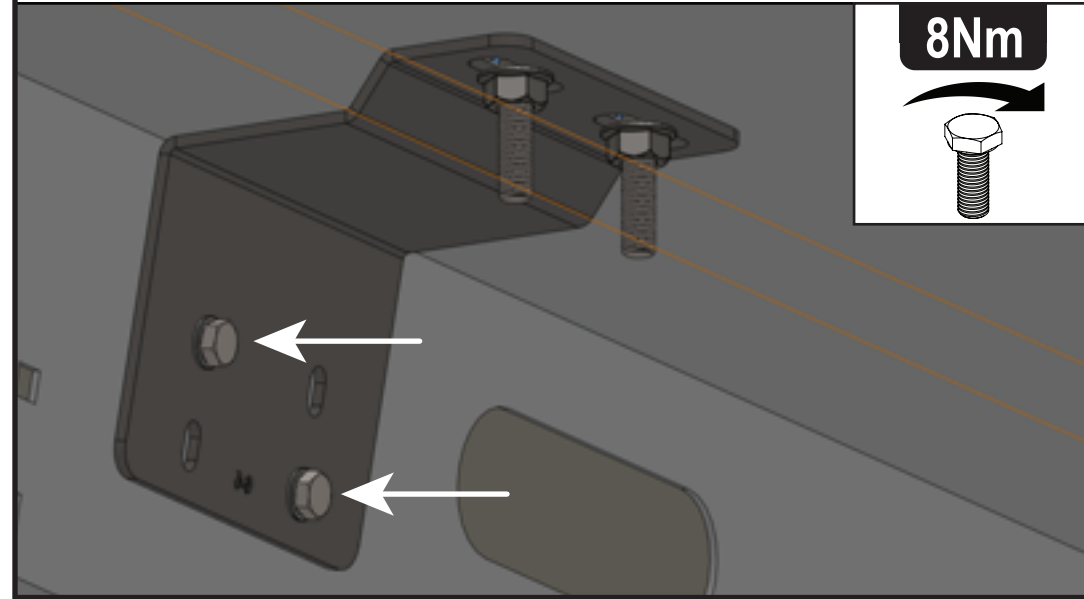

**12**

1.

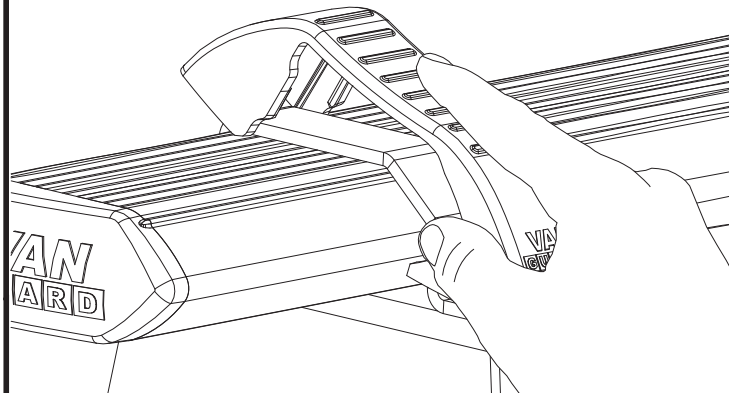

2.

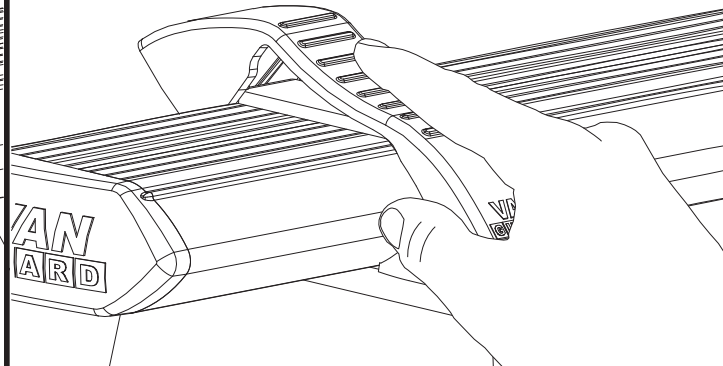

3.

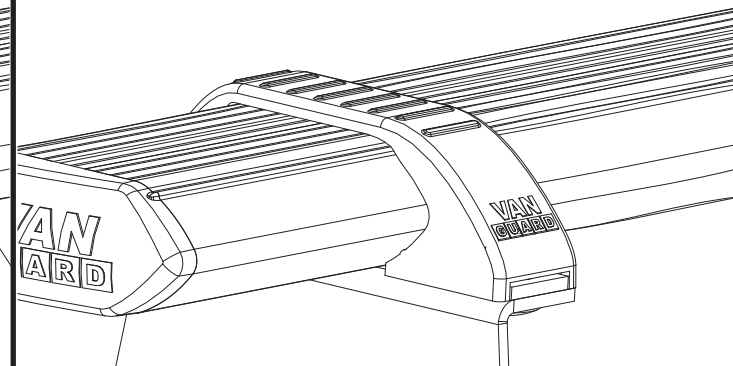



1. Regularly inspect all fixings and parts. Any damaged or worn parts should be immediately removed from the vehicle and replaced.

2. Take care when loading and unloading goods on to and off the vehicles roof.

**GB**

3. Van Guard Accessories LTD and/ or its distributors do not accept liability for:

- Any products that have been fitted incorrectly.
- Any products which have been fitted to the incorrect vehicle.
- Any products that have been modified in any way or are being used for any purpose that they are unintended for.

4. It is important that the end user receives this document and that instructions are retained for future use.



1. Inspecter régulièrement toutes les fixations et les pièces. Les pièces endommagées ou usées doivent être immédiatement retiré du véhicule et remplacé.

2. Prendre garde lors du chargement et du déchargement de marchandises vers et hors des véhicules toit.

**FR**

3. Van Guard Accessoires Ltd et/ ou ses distributeurs n'accepte pas de responsabilité pour:

- Les produits qui ont été ajustés de manière incorrecte.
- Les produits qui ont été montés sur le véhicule incorrect.
- Les produits qui ont été modifiés de quelque façon ou sont utilisés à toutes fins qu'ils sont involontaires.

4. Il est important que l'utilisateur final reçoit ce document et que les instructions soient conservés pour une utilisation futur.



1. Prüfen Sie regelmäßig alle Befestigungen und Teile. Alle verschlissenen oder beschädigten Teile sollten sofort aus dem Fahrzeug ausgebaut und erneuert.

2. Vorsicht beim Be- und Entladen von Gütern auf und abseits der Fahrzeuge.

**DE**

3. Van Guard Accessories LTD und/ oder seinen Händlern keine Haftung für:

- Sämtliche Produkte, die falsch montiert worden.
- Alle Produkte, die auf die falsche Fahrzeug.
- Alle Produkte, die nicht in irgendeiner Weise verändert oder verwendet für jeden Zweck, sie sind unbeabsichtigt.

4. Es ist wichtig, dass der Endbenutzer erhält dieses Dokument und die Anweisungen für eine zukünftige Verwendung aufbewahrt werden.



1. Undersøg med jævne mellemrum alle løsdele og fæstninger. Beskadigede eller slidte dele bør straks fjernes fra køretøjet og repareres eller erstattet.

2. Vær meget opmærksom ved lastning og losning af varer fra varevognens tag.

**DK**

3. VanGuard Accessories Ltd og/eller deres distributører accepterer ikke ansvar for:

- Produkter der ikke er monteret korrekt som angivet i monteringsvejledning.
- Produkter der er blevet monteret på et køretøj, de ikke er beregnede til.
- Produkter der er blevet modificerede på nogen måde eller bliver brugt på en måde, hvortil de ikke er beregnede.

4. Det er vigtigt, at dette dokument overdrages til slutbruger af produktet og at vejledning er gemt til senere brug.