

Technical Documentation Installation and Service Manual

BlazeCut Automatic Fire Suppression

T Series Systems



TDx00EA(S) and TVx00FA(S)



AUTOMATIC FIRE SUPPRESSION SYSTEMS



TABLE OF CONTENT:

1. INTRODUCTION	4
2. BASIC INFORMATION ABOUT THE SYSTEM	5
2.1. RETAIL PACKAGE CONTENTS.....	6
2.2. TECHNICAL SPECIFICATION AND TYPES	6
2.3. USE OF THE SYSTEM.....	8
3. COMPONENTS OF THE SYSTEM AND THEIR DESCRIPTION	12
4. INSTALLATION INSTRUCTIONS	14
4.1. FOLLOW THE FOLLOWING INSTRUCTIONS DURING INSTALLATION	15
4.2. LABEL.....	16
5. INSTRUCTIONS FOR FUNCTIONALITY INSPECTION AND MAINTENANCE.....	16
5.1. VISUAL INSPECTION	16
5.2. PRESSURE INSPECTION OF THE SYSTEM	16
5.3. IMPORTANT: IN THESE CASES THE BLAZECUT SERIES MUST BE REPLACED.....	17
6. INSTRUCTIONS FOR IN CASE OF FIRE PROCEDURE AFTER SYSTEM ACTUATION.	17
7. WARNINGS.....	17
8. INFORMATION ON EXTINGUISHING AGENT USED	18
8.1. DESCRIPTION OF EXTINGUISHING AGENT	18
8.2. PERMISSIBLE USES.....	18
8.3. IMPROPER USES	19
8.4. SOME PHYSICAL AND CHEMICAL PROPERTIES.....	20
8.5. WARNINGS	22
9. FIRST AID INSTRUCTIONS	22
10. CERTIFICATION AND TESTING.....	23
11. T SERIES CLAIMS AND WARRANTY	23

AUTOMATIC FIRE SUPPRESSION SYSTEMS



ANNEX NO. 1.....	24
12. PRESSURE MONITORING.....	24
12.1. PRESSURE SWITCH EAS AND FAS VERSION	24
12.2. ELECTRICAL CABLES AND CONDUITS	25
ANNEX NO. 2.....	26
1. BASIC INFORMATION ABOUT THE COMPONENTS	26
1.1. SPECIFICATION AND DESCRIPTION OF FUNCTION	26
1.2. USE	27
1.3. INSTALLATION AND CONNECTING.....	27
1.4. WIRING	28
1.5. ALARM PANEL TECHNICAL SPECIFICATIONS	29
1.6. DESCRIPTION OF FUNCTION OF THE SIGNALING UNIT	29
ANNEX NO. 3.....	30
1. BASIC INFORMATION ABOUT THE COMPONENTS	30
1.1. DESCRIPTION	30
1.2. USE	30
1.3. INSTALLATION AND CONNECTING.....	30
1.4. SIGNALING UNIT TECHNICAL SPECIFICATIONS	30
1.5. DESCRIPTION OF FUNCTION	31
ADDITIONAL NOTES.....	32

1. INTRODUCTION

MANUFACTURER INFORMATION

BlazeCut s.r.o., Brusnicová 3299/7, Chorvátsky Grob 900 25, Slovak Republic

GLOBAL HEAD OFFICE

BlazeCut Pty Ltd, 45 Evans St, Balmain NSW 2041 Australia
+61 2 8006 1300

www.blazecut.com; technical@blazecut.com

INSTRUCTIONS FOR USE OF THE MANUAL

This manual is intended to supply technical information for the trained and authorized BlazeCut Group. Any personnel performing installation, inspection, maintenance or replacement of components with the BlazeCut system shall have this manual available and proceed solely in accordance with it. Failure to follow the instructions in this manual and any other BlazeCut manuals may result in system malfunctioning, causing damage to the protected equipment and presents serious danger to the life and health of others.

SAFETY FIRST

Please read this manual in its entirety. Operation and installation instructions need to be fully understood before this BlazeCut product is installed. Failure to do so may void warranty. Your local governing regulations for safety and compliance must be followed.

In the figures the descriptions of the components are marked with numbers, the descriptions of steps are marked with a letter "S" and a number.

WARNINGS AND CAUTIONS



This symbol in the text represents warning of specific risk, danger, or warning of described procedure. Failure to follow the instructions in the text marked with this symbol may result in damage to property, loss of warranty, unforeseeable event or threat to safety, health or life of persons performing the operation on the system or persons in their vicinity. Do not proceed contrary to the instructions marked with such symbol.

FURTHER INFORMATION

BlazeCut® is a registered trademark of BlazeCut and is recorded in the Register of Community Trade Marks.

If any of the instructions in this manual are unclear or in case of further questions contact the BlazeCut Team.

WARNING

Please ensure that the safety instructions are fully understood before the equipment is put into service.

Do not modify any part of the BlazeCut components as this may cause serious injury or a failure of the system.

Always wear the appropriate protective equipment and clothing whilst installing or servicing.

This document is the property of BlazeCut. It is prohibited to reproduce it, copy it in whole or in part, or provide third parties with any related information without prior written consent of BlazeCut.

2. BASIC INFORMATION ABOUT THE SYSTEM

EXPLANATION OF TYPE NAME CAPTION

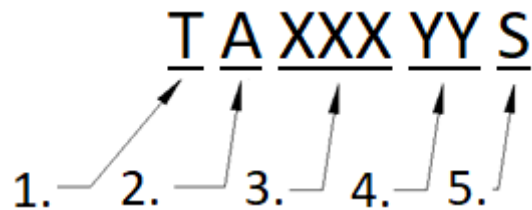

1. Part of caption stating the BlazeCut system series

T (Tube) – type of system using tube

2. Part of caption stating suited application

V – Vehicle

D – Device

3. Part of caption numerically stating tube length

025 – 25 cm (centimetres)

050 – 50 cm (centimetres)

100 – 100 cm (centimetres)

200 – 200 cm (centimetres)

300 – 300 cm (centimetres)

400 – 400 cm (centimetres)

500 – 500 cm (centimetres)

600 – 600 cm (centimetres)

4. Part of caption stating type of extinguishing agent

EA - extinguishing agent used HFC-227ea

FA - extinguishing agent used HFC-236fa

5. Part of caption indicating a pressure switch is included. E.g. TD200EAS

NOTE: If a pressure switch is not installed the fifth caption will be absent. E.g. TD200EA

DESCRIPTION OF SYSTEM

Commercial name: BlazeCut

Characteristics: Automatic Fire Suppression System

Type: Tube series (T Series)

The BlazeCut T Series system is designed to protect small closed spaces with greater risks of fire. The BlazeCut T Series system operates automatically without any external power source. Extinguishing agent is stored in a storage tube, which also serves to apply extinguishing agent directly to the fire at its source. In case of fire the detection tube degrades by the effect of fire or high temperature and melts. Extinguishing agent is then released through a nozzle that is created.

Depending on the type used, the BlazeCut T Series is suitable for the protection of spaces such as:

- Boat engine rooms,
- Engine compartments of road vehicles (cars, SUVs, vans, recreational vehicles, minibuses, old timers, etc.),
- Engine compartments of other vehicles (quads, small tractors, motor mowers, motorized carts, etc.),
- Electrical switchboards, fuse boxes, electrical supply sources, battery spaces, car batteries, inductors,
- Other enclosed spaces with risk of fire (network installations, servers, audio-video equipment, etc.).

- ATM's (Automatic teller machines), Electric fuel bowsers etc.

T SERIES STANDARD SIZES

2.1. RETAIL PACKAGE CONTENTS

Table 1. Standard Retail package contents excluding units longer than 4 metres(400 cm)

Component	Amount
BlazeCut system with a pressure gauge	1
Clean extinguishing agent HFC-227ea/HFC-236fa	depending on the type 0.25 – 1 kg
Installation cable ties	depending on the type
Information sticker to label protected enclosure	1
User manual	1
Information about substance	1
BlazeCut logo sticker	1

BlazeCut system was designed and tested as a whole using original components with specific properties. Using other components and spare parts than those supplied by the manufacturer is prohibited and may change the functionality of the system and causes loss of warranty. Fastening components for detection tube are exempted, provided other installation and maintenance instructions are followed and provided they are suitable for use in the protected enclosure (heat resistance etc.). To order original spare parts and for further information contact the supplier of BlazeCut system.

Please Note: Only the 1 to 4 metre systems can be supplied in a retail box.

2.2. TECHNICAL SPECIFICATION AND TYPES

Table 2. Types of BlazeCut T Series systems described in this manual

Type name	Amount of extinguishing agent (grams)	Caption
TD025EA(S)*	50 ± 2	T – tube (tube)
TV025FA(S)*	50 ± 2	D – systems designated to devices (D – device)
TD050EA(S)*	100 ± 2	V – systems designated to vehicles (V – vehicle)
TV050FA(S)*	100 ± 2	Three digit number – approximate length of the tube in cm
TD100EA(S)	250 ± 5	EA – extinguishing agent used HFC-227ea
TV100FA(S)	250 ± 5	FA – extinguishing agent used HFC-236fa
TD200EA(S)	500 ± 5	S – Pressure switch fitted
TV200FA(S)	500 ± 5	
TD300EA(S)	750 ± 10	
TV300FA(S)	750 ± 10	
TD400EA(S)	1000 ± 10	
TV400FA(S)	1000 ± 10	
TV500EA(S)*	1250 ± 10	
TV500FA(S)*	1250 ± 10	
TV600EA(S)*	1500 ± 10	
TV600FA(S)*	1500 ± 10	

*not available in a retail box

AUTOMATIC FIRE SUPPRESSION SYSTEMS



Inner diameter of the tube: 15 mm

Outer diameter of the tube: 18 mm

Standard operation pressure at 20°C: 2 – 6 bar**

**** NOTE:** Due to physical and chemical properties of the agent, pressure in the tube can vary depending on the ambient temperature. The higher the ambient temperature, the higher pressure in the tube and vice versa at very low temperatures the pressure of agent vapors is zero (see Chapter 8.).

Indicator on the pressure gauge can vary from 0 bar (when temperatures are very low) to 15 bar (when temperatures are very high). This is not a sign of defect in the system.

When using a type with the pressure switch, the system is pressurized with nitrogen (N2) to higher pressure as normal vapor pressure of the extinguishing agent to prevent from false alarms, see also Annex no.1 of the manual.

Minimum and maximum operation temperature (without the pressure switch):

- From - 40°C to + 80°C for systems with HFC-236fa extinguishing agent
- From - 40°C to + 60°C for systems with HFC-227ea extinguishing agent

Minimum and maximum operation temperature (with the pressure switch):

- From - 20°C to + 80°C for systems with HFC-236fa extinguishing agent
- From - 20°C to + 60°C for systems with HFC-227ea extinguishing agent

Burst pressure: 20 bar

Material of the tube: heat sensitive plastic

Material of the fittings: stainless steel

Material of the pressure gauge: Nickel plated brass

Table 3. BlazeCut T Series system details

Model	Type of agent	Amount of agent (gm)	Length of system (cm)*	Outside diameter of tube (mm)	Operation temperature without pressure switch	Operation temperature with pressure switch	Burst temperature	Burst Pressure at source (bar)
TD025EA	HFC-227ea	50 ± 2	28	18	from -40°C to +60°C	from -20°C to +60°C	90°C – 100°C	20
TD050EA	HFC-227ea	100 ± 2	53	18	from -40°C to +60°C	from -20°C to +60°C	90°C – 100°C	20
TD100EA	HFC-227ea	250 ± 5	113	18	from -40°C to +60°C	from -20°C to +60°C	90°C – 100°C	20
TD200EA	HFC-227ea	500 ± 5	215	18	from -40°C to +60°C	from -20°C to +60°C	90°C – 100°C	20
TD300EA	HFC-227ea	750 ± 10	319	18	from -40°C to +60°C	from -20°C to +60°C	90°C – 100°C	20
TD400EA	HFC-227ea	1 000 ± 10	422	18	from -40°C to +60°C	from -20°C to +60°C	90°C – 100°C	20
TD500EA	HFC-227ea	1 250 ± 10	526	18	from -40°C to +60°C	from -20°C to +60°C	90°C – 100°C	20
TD600EA	HFC-227ea	1 500 ± 10	630	18	from -40°C to +60°C	from -20°C to +60°C	90°C – 100°C	20
TV025FA	HFC-236fa	50 ± 2	28	18	from -40°C to +80°C	from -20°C to +80°C	110°C – 120°C	20
TV050FA	HFC-236fa	100 ± 2	53	18	from -40°C to +80°C	from -20°C to +80°C	110°C – 120°C	20

TV100FA	HFC-236fa	250 ± 5	113	18	from -40°C to +80°C	from -20°C to +80°C	110°C – 120°C	20
TV200FA	HFC-236fa	500 ± 5	215	18	from -40°C to +80°C	from -20°C to +80°C	110°C – 120°C	20
TV300FA	HFC-236fa	750 ± 10	319	18	from -40°C to +80°C	from -20°C to +80°C	110°C – 120°C	20
TV400FA	HFC-236fa	1 000 ± 10	422	18	from -40°C to +80°C	from -20°C to +80°C	110°C – 120°C	20
TV500FA	HFC-236fa	1 250 ± 10	526	18	from -40°C to +80°C	from -20°C to +80°C	110°C – 120°C	20
TV600FA	HFC-236fa	1 500 ± 10	630	18	from -40°C to +80°C	from -20°C to +80°C	110°C – 120°C	20

***NOTE:** All T Series systems with integrated pressure switch have additional length of 8 cm. E.g. system TD100EAS has a total length of 121 cm

OPTIONAL COMPONENTS

The BlazeCut T Series can send a signal after its activation via additional components using a pressure switch with electrical output of notifying the activation of the system. These components can be connected to any type of BlazeCut T Series. All pressure switches must be preinstalled in the factory before supply. For further information contact the supplier of the BlazeCut system.

The BlazeCut T Series can use external alarm or signaling unit connected to the pressure switch, the alarm or signaling units alert the driver or personnel with light and sound signals in case of fire or system activation. These components can be connected to any type of T Series equipped with a pressure switch. For further information contact the supplier of the BlazeCut system.

Installation, use, function and service of selected optional components is described in annexes of the Installation and service manual or supplied as a separate manual. For more information contact the supplier.

List of compatible BlazeCut electrical components for the T Series systems

Pressure Switch APS001 (EAS and FAS versions) – simple mechanical switch with one switch point (fire alarm).
***The APS001 has to be fitted in Factory during the filling process.

Alarm Panel TAP200 – IP65 small and simple Alarm Panel in robust aluminum body with, universal in dash or external bracket installation. Monitors the pressure switch for fault.

Signaling Unit ASU001 - simple and cost-effective sound and light signaling unit.

Sounder ASR001 – multi tone red sounder, high base, IP65 rated.

Beacon ABR001 – red xenon beacon, high base, IP65 rated.

Signaling Unit ASU002 – red sounder and beacon, high base, IP44 rated

Signaling Unit ASU003 – red sounder and beacon, high base, IP65 rated

2.3. USE OF THE SYSTEM



System BlazeCut is designed to protect of equipment in closed spaces. Use in partially or completely open spaces or spaces with strong air circulation may significantly decrease the efficiency of the system. For more information about use of the system if people are constantly present in the protected area contact your supplier.

Maximum volume coverage depends on two major factors: Maximum ambient temperature in the protected enclosure and design concentration required. To guide which system to select below tables list the maximum volume coverage for each agent weight in certain design concentration. The design concentrations in tables are to cover most of standard applications for respective agent. For HFC-227ea the design concentration is to cover most of fixed applications with Class A and electrical fires. For HFC-236fa the design concentration covers typical vehicle applications with Class A, electrical fires and most common Class B and C fires.

AUTOMATIC FIRE SUPPRESSION SYSTEMS



Note: For applications with different design concentration required use the BlazeCut Tool Calculator, Concentration Table or contact the supplier of the system.

Table 4. Volume coverage HFC-227ea

Temp (°C)	Maximum volume coverage in m ³ with 7.0% design concentration							
	TD025EA	TD050EA	TD100EA	TD200EA	TD0300EA	TD400EA	TD500EA	TD600EA
-40	0.07	0.14	0.35	0.71	1.06	1.41	1.77	2.12
-35	0.07	0.14	0.36	0.72	1.09	1.45	1.81	2.17
-30	0.07	0.15	0.37	0.74	1.11	1.48	1.85	2.22
-25	0.08	0.15	0.38	0.76	1.14	1.52	1.89	2.27
-20	0.08	0.15	0.39	0.77	1.16	1.55	1.94	2.32
-15	0.08	0.16	0.40	0.79	1.19	1.58	1.98	2.38
-10	0.08	0.16	0.40	0.81	1.21	1.62	2.02	2.43
-5	0.08	0.17	0.41	0.83	1.24	1.65	2.06	2.48
0	0.08	0.17	0.42	0.84	1.26	1.69	2.11	2.53
5	0.09	0.17	0.43	0.86	1.29	1.72	2.15	2.58
10	0.09	0.18	0.44	0.88	1.32	1.75	2.19	2.63
15	0.09	0.18	0.45	0.89	1.34	1.79	2.24	2.68
20	0.09	0.18	0.46	0.91	1.37	1.82	2.28	2.73
25	0.09	0.19	0.46	0.93	1.39	1.86	2.32	2.78
30	0.09	0.19	0.47	0.95	1.42	1.89	2.36	2.84
35	0.10	0.19	0.48	0.96	1.44	1.92	2.41	2.89
40	0.10	0.20	0.49	0.98	1.47	1.96	2.45	2.94
45	0.10	0.20	0.50	1.00	1.49	1.99	2.49	2.99
50	0.10	0.20	0.51	1.01	1.52	2.03	2.53	3.04
55	0.10	0.21	0.52	1.03	1.55	2.06	2.58	3.09
60	0.10	0.21	0.52	1.05	1.57	2.09	2.62	3.14

Table 5. Design Concentrations for HFC-227ea

Class A Fires		6.7*	
Electrical Fires		7.0*	
Class B and C Fires			
1-Propane	10.0	Isopropanol	9.8
2.butoxyethanol	9.0	JP 4	9.0
Acetone	10.0	JP 5	9.0
Acetonitrille	7.0	Kerosene	9.6
Benzene	9.5	Methane	7.2
Commercial Heptane	8.7	Methanol	15.2
Commercial Hexanes	9.0	Methyl Ethyl Ketone	9.6
Crude Oil	8.5	Methyl Isobutyl Ketone	9.1
Cyclohexane	9.4	Methyl Tert Butyl Ether	8.8
Cyclopentanone	9.6	n-Heptane	9.6
Denatured Alcohol	9.8	n-Pentane	8.8
Diesel fuel	8.7	Propane	8.7
Diethyl Ether	9.8	Pyrrolidine	9.5
Ethanol	12.6	Tetrahydrofuran	9.6
Ethyl Acetate	8.9	Toluene	7.6
Gasoline-87 Octane Unleaded	9.0	Transformer Oil	9.5
Hexene	7.6	1-Butane	8.6
Hydraulic Fluid	8.5	Xylene	7.8
Hydraulic Oils	7.7		

*Minimum design concentration according to NFPA 2001, 2018

Table 6. Volume coverage HFC-236fa

Temp (°C)	Maximum volume coverage in m3 with 9.0% design concentration							
	TV025FA	TV050FA	TV100FA	TV200FA	TV0300FA	TV400FA	TV500FA	TV600FA
-40	0.06	0.12	0.30	0.59	0.89	1.19	1.48	1.78
-35	0.06	0.12	0.30	0.61	0.91	1.22	1.52	1.82
-30	0.06	0.12	0.31	0.62	0.94	1.25	1.56	1.87
-25	0.06	0.13	0.32	0.64	0.96	1.28	1.60	1.92
-20	0.07	0.13	0.33	0.65	0.98	1.31	1.63	1.96
-15	0.07	0.13	0.33	0.67	1.00	1.34	1.67	2.01
-10	0.07	0.14	0.34	0.68	1.03	1.37	1.71	2.05
-5	0.07	0.14	0.35	0.70	1.05	1.40	1.75	2.10
0	0.07	0.14	0.36	0.71	1.07	1.43	1.79	2.14
5	0.07	0.15	0.36	0.73	1.09	1.46	1.82	2.19
10	0.07	0.15	0.37	0.74	1.12	1.49	1.86	2.23
15	0.08	0.15	0.38	0.76	1.14	1.52	1.90	2.28
20	0.08	0.16	0.39	0.78	1.16	1.55	1.94	2.33
25	0.08	0.16	0.40	0.79	1.19	1.58	1.98	2.37
30	0.08	0.16	0.40	0.81	1.21	1.61	2.01	2.42
35	0.08	0.16	0.41	0.82	1.23	1.64	2.05	2.46
40	0.08	0.17	0.42	0.84	1.25	1.67	2.09	2.51
45	0.09	0.17	0.43	0.85	1.28	1.70	2.13	2.55
50	0.09	0.17	0.43	0.87	1.30	1.73	2.17	2.60
55	0.09	0.18	0.44	0.88	1.32	1.76	2.20	2.64
60	0.09	0.18	0.45	0.90	1.34	1.79	2.24	2.69
65	0.09	0.18	0.46	0.91	1.37	1.82	2.28	2.73
70	0.09	0.19	0.46	0.93	1.39	1.85	2.32	2.78
75	0.09	0.19	0.47	0.94	1.41	1.88	2.35	2.83
80	0.10	0.19	0.48	0.96	1.44	1.91	2.39	2.87

Table 7. Design Concentrations for HFC-236fa

Class A Fires		6.3*	
Electrical Fires		7.0	
Class B and C Fires			
1-Propane	10.0	Isopropanol	9.8
2.butoxyethanol	9.0	JP 4	9.0
Acetone	10.0	JP 5	9.0
Acetonitrille	7.0	Kerosene	9.6
Benzene	9.5	Methane	7.2
Commercial Heptane	8.7	Methanol	15.2
Commercial Hexanes	9.0	Methyl Ethyl Ketone	9.6
Crude Oil	8.5	Methyl Isobutyl Ketone	9.1
Cyclohexane	9.4	Methyl Tert Butyl Ether	8.8
Cyclopentanone	9.6	n-Heptane	9.6
Denatured Alcohol	9.8	n-Pentane	8.8
Diesel fuel	8.7	Propane	8.7
Diethyl Ether	9.8	Pyrrolidine	9.5
Ethanol	12.6	Tetrahydrofuran	9.6
Ethyl Acetate	8.9	Toluene	7.6
Gasoline-87 Octane Unleaded	9.0	Transformer Oil	9.5
Hexene	7.6	1-Butane	8.6
Hydraulic Fluid	8.5	Xylene	7.8
Hydraulic Oils	7.7		

*Minimum design concentration according to NFPA 2001, 2018

The fire suppressing depends on many other factors apart from the amount of extinguishing agent, such as the properties of the flammable substances in the space, shape and degree of closure of the space, air circulation

AUTOMATIC FIRE SUPPRESSION SYSTEMS



and ambient temperature. In order to reach desired extinguishing concentration and effective use of BlazeCut system consult the choice of type, amount of agent, use of extinguishing agent and installation method with the supplier of the system.

It is necessary that conditions in the protected area are in accordance with allowed parameters of the system, especially minimum and maximum temperature in the protected area.

Remember that there are a lot of factors and variables that affect the extinguishing process in case of fire. Is not possible to guarantee total suppression of fire in the protected enclosure under all circumstances.

Use of the system is also limited by the properties of extinguishing agent and its possible application. Detailed information is included in Chapter 8.

WARNING



Install and use The BlazeCut T Series only with originally supplied components. Do not replace anything in the system, use only original components and spare parts. Use of components not approved by the manufacturer causes loss of warranty, may cause malfunction of the system and provides threat to safety and health of people.



The BlazeCut T Series is designed as independently operating unit. It is not possible to connect several independent systems into one unit.



The BlazeCut T Series is not compatible with other fire suppression systems, do not try to connect the system to any other equipment.



The system may be installed only by persons older than 18 years, physically and mentally capable. Incorrect interference with the system may cause malfunction of the system and provides threat to safety and health of people.



The system is not designed to be used as portable fire extinguisher. Do not try to suppress fire by holding the system in hands or sprinkling the extinguishing agent directly into the fire. Do not use the system in any other way than described in this manual.

3. COMPONENTS OF THE SYSTEM AND THEIR DESCRIPTION

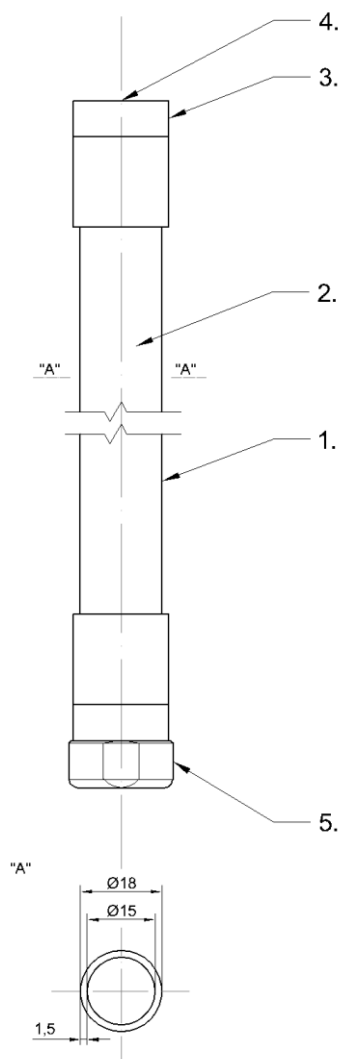

Scheme of the system and description of components, all data in millimeters

1. Pressure tube
2. Extinguishing agent depending on the type HFC-227ea or HFC-236fa
3. Fitting of the tube with outlet M10x1 and with the filling valve
4. Sealing screw (inside the fitting)
5. Pressure gauge of the system

PRESSURE TUBE

The Plastic tube serves as storage for the extinguishing agent. It can be filled with extinguishing agent HFC-227ea or HFC-236fa and the amount depends on the type. The Extinguishing agent is in the form of liquefied gas. Pressure in the tube varies depending on the ambient temperature. Due to physical and chemical properties of the agent, pressure in the tube can vary depending on the ambient temperature. The higher the ambient temperature, the higher pressure in the tube and vice versa at very low temperatures the pressure of agent vapors is zero (see Chapter 8.). Indicator on the pressure gauge can vary from 0 bar (when temperatures are very low) to 15 bar (when temperatures are very high). This is not a sign of defect in the system.



Pressure tube is under constant pressure. Do not damage the tube, do not puncture or throw. During transportation secure against movement. During transfer do not rub against the ground. Do not mend damaged tube. Do not store or transport in vicinity of strong sources of heat, aggressive chemical substances (caustic, corrosive substances), prevent contact with sharp objects, vibrations or loading with other objects. Store in dry and well ventilated rooms.

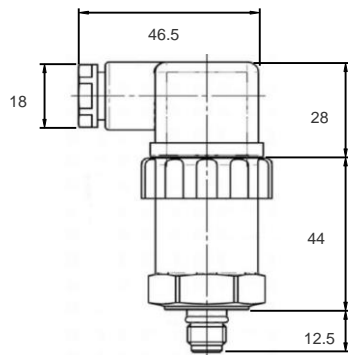

Pressure Switch APS001 (sideview)

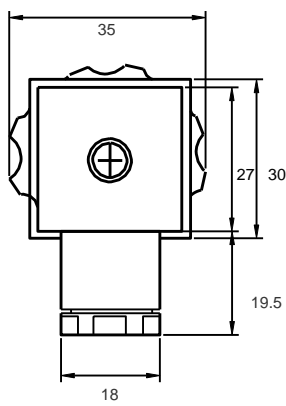

Pressure Switch APS001 (frontview)

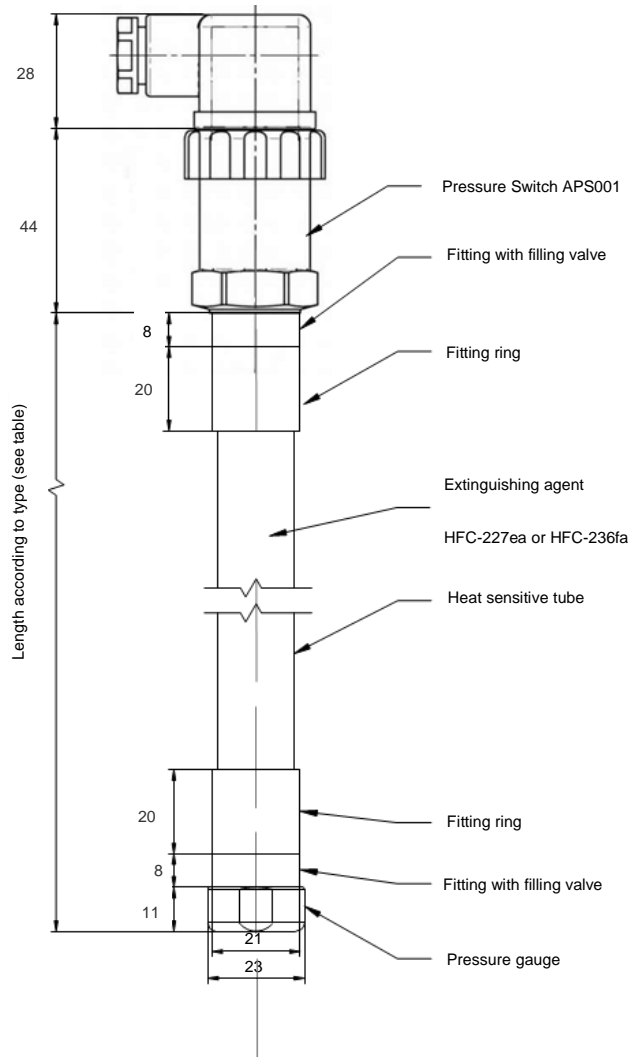

Table 8. Length and weight of systems

System Type	Type of agent	Amount of agent (g)	Length of system (cm)	Gross weight of system (kg)
TV(D)025F(E)A	HFC-227ea/HFC-236fa	50 ± 2	28	0.20
TV(D)050F(E)A	HFC-227ea/HFC-236fa	100 ± 2	53	0.27
TV(D)100F(E)A	HFC-227ea/HFC-236fa	250 ± 5	113	0.47
TV(D)200F(E)A	HFC-227ea/HFC-236fa	500 ± 5	215	0.80
TV(D)300F(E)A	HFC-227ea/HFC-236fa	750 ± 10	319	1.14
TV(D)400F(E)A	HFC-227ea/HFC-236fa	1000 ± 10	422	1.46
TV(D)500F(E)A	HFC-227ea/HFC-236fa	1250 ± 10	526	1.82
TV(D)600F(E)A	HFC-227ea/HFC-236fa	1500 ± 10	630	2.12
TV(D)025F(E)AS*	HFC-227ea/HFC-236fa	50 ± 2	35	0.33
TV(D)050F(E)AS*	HFC-227ea/HFC-236fa	100 ± 2	60	0.40
TV(D)100F(E)AS*	HFC-227ea/HFC-236fa	250 ± 5	120	0.60
TV(D)200F(E)AS*	HFC-227ea/HFC-236fa	500 ± 5	222	0.93
TV(D)300F(E)AS*	HFC-227ea/HFC-236fa	750 ± 10	326	1.27
TV(D)400F(E)AS*	HFC-227ea/HFC-236fa	1000 ± 10	429	1.59
TV(D)500F(E)AS*	HFC-227ea/HFC-236fa	1250 ± 10	533	1.95
TV(D)600F(E)AS*	HFC-227ea/HFC-236fa	1500 ± 10	637	2.25

*including fitted Pressure Switch APS001 with cable plug



Always handle the pressure tube as if it were under pressure, unless it is directly verified that it is completely empty.

FITTINGS OF THE TUBE

The Fittings of the tube close the tube and keep the system under pressure. The filling valves are fitted in the fittings and closed by a pressure gauge on one end and sealing screw or pressure switch on the other end. The pressure switch is fitted at the factory when ordered.



Do not try to remove fittings of the tube if it is under pressure. Protect the fittings from corrosive substances during storage and transportation.

PRESSURE GAUGE

Actual pressure in the system can be determined by reading the value on the pressure gauge, which is mounted on the fitting tube. Try to install the pressure gauge so that the pressure values can be read.

4. INSTALLATION INSTRUCTIONS

1. The tube in the retail packaging is secured with cable ties. Cut the cable ties and proceed carefully not to damage the tube.
2. The packaging contains installation cable ties for installation in the protected enclosure. It is possible to use other method of mounting depending on the method of installation in the protected enclosure provided other installation instructions are followed and provided they are suitable for use in the protected enclosure (heat resistance etc.). If possible it is recommended to use durable mounts such as rubber insulated metal clamps to prevent detachment of the tube in case of fire. Do not use a steel fastening material for installation (steel clamps, sheet, wire etc.) that might be in contact with the pressure tube.
3. Shape the tube into desired shape during installation depending on the shape of the protected enclosure.
4. Place self-adhesive information label (TLA001) to the protected enclosure onto a visible place after installation. Place the label on an even smooth surface. Clean the surface thoroughly before sticking. Do not place the label at places reaching high temperatures (engine block etc.)

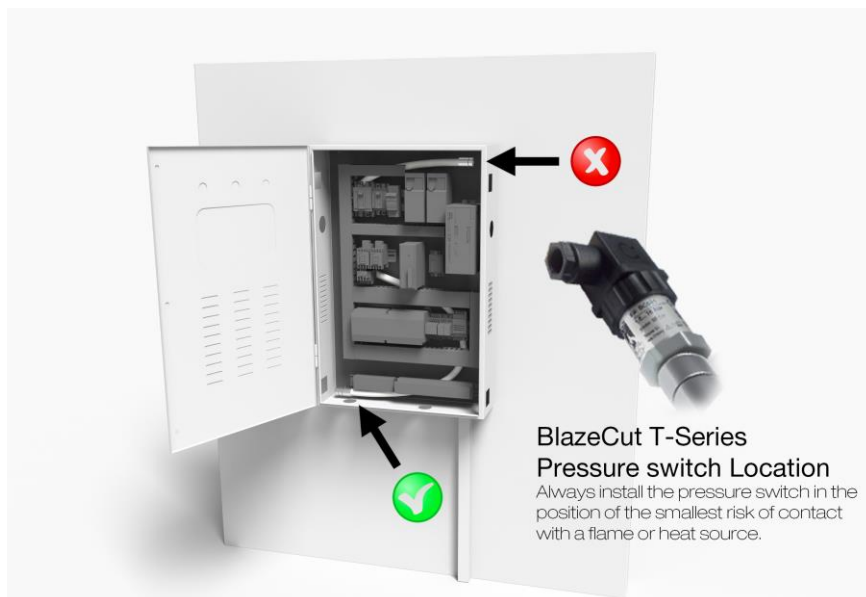

Always place the pressure switch in the lower part of the risk area to avoid direct flames and heat.

4.1. FOLLOW THE FOLLOWING INSTRUCTIONS DURING INSTALLATION

1. Place the BlazeCut T Series in the proximity of the protected equipment where the risk of fire is greatest (in the proximity of engines, parts of the systems reaching highest temperatures, systems containing flammable liquids or gases, protected objects, electrical installations, connections, circuit breakers, inductors, batteries etc.).
2. For maximum efficiency and engine protection, do not place of the BlazeCut T Series behind barriers that could restrict or reduce the fire suppression effect of the system by preventing direct penetration of extinguishing agent into the protected enclosure.
3. Proceed carefully during installation not to damage the tube with sharp objects. Do not break the tube, do not bend forcibly. Make sure not to damage the tube after closing the protected enclosure (e.g. after closing the engine compartment, installation of covers, equipment etc.) and also that no part is hit by moving parts of the engine (engine fans etc.)
4. The BlazeCut T Series must be firmly mounted in the protected enclosure so that it does not move. Use included installation cable ties or other suitable methods of fastening. The maximum distance between the mounts shall not be more than 25 cm.
5. Fasten the system to firm parts of the construction in the protected enclosures. Do not fasten to parts, which move during operation of the vehicle. Make sure that the fastening components are not damaged during operation of the vehicle. If any part of the BlazeCut T Series moves out of its place of installation extinguishing effect of the system may be decreased, the part or the vehicle may be damaged.
6. The BlazeCut T Series cannot be to in direct contact with the parts or in immediate proximity of parts that heat to temperature of more than 80°C during operation when using HFC-236fa agent and more than 60°C when using HFC-227ea agent (e.g. engine block, engine turbocharger, exhaust pipes, heated parts of inductors etc.).
7. Install the system so that it is not exposed to aggressive chemical substances (caustic, acids, solvents, corrosive substances etc.) and to direct influence of weather conditions.
8. When fastening the system make sure not to damage other parts of the vehicle.
9. The tube cannot be in direct contact with galvanized or zinc plated objects as these have adverse effects on plastics in general and may cause to plastic tube galvanic corrosion what might result in a short period of time to degradation and damage of the tube.



Be aware of the danger posed by the protected device. Do not install and perform maintenance of the system while the engine of vehicles is in operation.



In the case of work in the vicinity of electrical equipment observe corresponding safety rules and instructions. Work on electrical installations may be performed only by qualified persons.



The tube has minimum bending radius of approximately 16 cm. Do not bend the tube under this radius. Excessive bending can damage the tube (rupture, breaking) and destroy the tube. As a result of the damage the extinguishing agent can splash out and provide threat to health of persons.



The tube needs to be mounted away from hot parts that can exceed the burst temperature ratings. Try to avoid mounting directly above heated parts, rather mount the tube to one side of the heated parts.

4.2. LABEL

A Label is supplied with each BlazeCut T Series system to ensure that the operator or people that may come in contact with the system are informed about its presence and operation. These also can be ordered separately.

Part No.	Description	Comment
TLA001	General Warning label for T Series	To notify there is a fire suppression system.



General warning label TLA001

The TLA001 comes standard in the retail box and can be ordered as a spare part to replace if ever damaged.

5. INSTRUCTIONS FOR FUNCTIONALITY INSPECTION AND MAINTENANCE

The BlazeCut T Series does not require any special maintenance. It is recommended to visually inspect the system and its state between every month and three months dependent on the type of environment it has been installed in.

5.1. VISUAL INSPECTION

During the movement of the tube bubbles of gas in the extinguishing agent will be visible. This indicates that extinguishing agent is in the tube and the BlazeCut T Series is functional. Visually inspect the overall state of the equipment. Focus on possible damage: deep grooves on the tube, signs of strain damage on the tube (change of colour of the tube), dents on the tube and other deformations, corrosion of the metal parts of the system (fittings of the tube, pressure gauge), other visible signs of damage. Inspect the fitting parts of the system for any leaks and signs of leakage of extinguishing agent from the system.

5.2. PRESSURE INSPECTION OF THE SYSTEM

Due to physical and chemical properties of the agent, pressure in the tube can vary depending on the ambient temperature. The higher the ambient temperature, the higher pressure in the tube and vice versa at very low temperatures the pressure of agent vapors is zero (see Chapter 8.).

Indicator on the pressure gauge can vary from 0 bar (when temperatures are very low) to 15 bar (when temperatures are very high). This is not a sign of defect in the system.

Table 9. Overview of inspections

	Period / interval	Obligatory scope
1.	Every 1 to 3months	<ol style="list-style-type: none"> 1. Overall inspection of the system for damage or wear. 2. Check mounts for being secure replace or tighten where necessary. 3. Check for bubbles of gas in the extinguishing agent. 4. Check pressure at normal operating temperature.
2.	5 to 10 years	<ol style="list-style-type: none"> 1. Dependent on being in a passive or harsh environment, the T Series may need replacing if any of the above steps fail.

5.3. IMPORTANT: IN THESE CASES THE BLAZECUT SERIES MUST BE REPLACED

1. The system was used or emptied from other reason.
2. The system was exposed to direct fire.
3. The tube shows signs of damaged as described in chapter "Visual Inspection".
4. Metal parts of the equipment are corroded or shows visible signs of damage as described in chapter "Visual Inspection".

Inspection and test intervals stated in the table in Chapter 5.2 are minimum intervals required by the manufacturer. If the legislation in place of installation require shorter intervals as stated in the table or additional inspections and tests, which are not stated in the table, it is necessary that these inspections are performed in accordance with this legislation.

6. INSTRUCTIONS FOR IN CASE OF FIRE PROCEDURE AFTER SYSTEM ACTUATION.



In case of fire in the vehicle the driver must immediately stop the vehicle, stop the engine of the vehicle and perform further measures according to operation instructions of the vehicle (for example cut-off the supply of fuel/gas) in order to protect the persons and property according to applicable legislation.



The extinguishing agent does not leave residue. Ventilate the protected enclosure properly, do not enter in the area before ventilation. Remove the used system from the protected enclosure. The same procedure should be followed after the release of extinguishing agent from other reasons (system damage etc.).



In case of fire the system activates automatically burning the tube without previous warning. In case of fire do not come into direct proximity of the system, there is a risk of being affected by extinguishing agent.

7. WARNINGS



In case of activation of the system do not enter the protected enclosure and do not open the covers of the protected enclosure, wait for total release of extinguishing agent.



The system is under constant pressure. Any interference with the system is prohibited.



Any interference or repair of the system may be performed by qualified persons ensuring correct technical practice. Do not repair or replace anything in the BlazeCut T Series. System interference or replacements shall result in loss of warranty and may cause malfunction of the system or provide danger to persons.



Do not interfere with the system if it was exposed to high temperature (as a result of operation of the protected device or after exposure to fire etc.). If the system is hot, the temperature of extinguishing agent increases and pressure in the system increases. If the pressure in the system is higher than 15 bar the system is reaching burst pressure. In this case the tube must not be mechanically stressed. Release of a hot extinguishing agent under high pressure can cause serious injury. Wait till the system cools down.



In case of leakage of liquid extinguishing agent during handling the system use impervious working gloves.



Do not try to suppress the fire holding the BlazeCut T Series close to fire or by throwing it into the fire. There can be a high danger of serious injury.

8. INFORMATION ON EXTINGUISHING AGENT USED

The BlazeCut T Series uses extinguishing agent depending on the type:

- HFC-236fa; chemical name: 1,1,1,3,3,3-Hexafluoropropane. It is halogen derivative of hydrocarbons. It is liquefied hydrocarbon gas, colourless, slightly ethereal odour.
- HFC-227ea; chemical name: 1,1,1,2,3,3,3-Heptafluoropropane. It is halogen derivative of hydrocarbons. It is liquefied hydrocarbon gas, colourless and odourless.

The system contains fluorinated greenhouse gases covered by the Kyoto Protocol.

The extinguishing agent HFC-227ea used in the BlazeCut T Series is UL recognized and FM Approved.

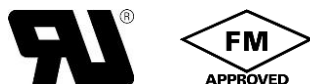

The extinguishing agent HFC-236fa used in the BlazeCut T Series is UL recognized.



Amount and type of extinguishing agent is stated in chapter 2.2 and on the information label of each system.

8.1. DESCRIPTION OF EXTINGUISHING AGENT

Extinguishing agent is clean extinguishing medium, used in the BlazeCut T Series for volume fire suppression. Extinguishing effects are due to cooling and anticatalyst effect. Extinguishing agent siphons heat from fire, enters the chain chemical reaction of burning, slows this reaction and stops it.

Extinguishing agent is not toxic or poisonous, it does not have carcinogenic or mutagenic effects and it is considered environmentally accepted substitute for halon extinguishing agents harmful to the environment used in the past.

MAIN ADVANTAGES OF EXTINGUISHING AGENT

- electrically non-conductive
- non-corrosive
- resistant to temperature changes
- safe for people when safety instructions are followed
- leaves no residue
- does not damage equipment or objects
- zero ozone depletion potential (ODP - Ozone Depletion Potential)

8.2. PERMISSIBLE USES

Extinguishing agent may be used for the following classes of fire:



Class A - flammable combustibles (creating flames)



Class B - flammable liquids



Class C – flammable gaseous substances



System is suitable for fire suppression of electrical equipment under voltage.

AUTOMATIC FIRE SUPPRESSION SYSTEMS



Always consult suitability of use of the system and type of extinguishing agent in specific conditions with the supplier.

After long exposure of extinguishing agent to heat the agent decomposes thermally creating dangerous products. In case of installation to enclosures with risk of smouldering solid (e.g. wood, coal, paper, textiles etc.) use the BlazeCut T Series with additional components – pressure switch and outlet for signalization of system activation.

Although the extinguishing agent is not toxic or poisonous, unnecessary excessive exposure of persons to its influence should be avoided. Under no circumstances should persons be exposed to the extinguishing agent for more than 5 minutes also in case when the extinguishing concentration does not exceed the LOAEL level (see toxicity data in the table below).

The BlazeCut system is primarily designed for small enclosed areas and equipment where people are not normally present (or only for a short time for inspection, maintenance, etc.), or in small rooms that can be vacated within 30 seconds of activation of the system.

If people are constantly present in the protected area, always consult the use of the system with the supplier. The system must be designed so that when the extinguishing agent is released the extinguishing concentration level which could be dangerous to people is not exceeded. It is also necessary to establish additional local measures to evacuate people from the protected area as soon as possible.



During the system activation the extinguishing agent is discharged from the tube under high pressure and at very low temperature. No permanent work place should be placed less than 1 meter from the system if the system is not installed in enclosure that prevents the extinguishing agent being discharged onto the people or no other barriers are in place preventing the extinguishing agent being discharged onto the people.

8.3. IMPROPER USES

Extinguishing agent is not suitable for fire suppression in spaces with:

- Certain chemicals or mixtures of chemicals, such as cellulose nitrate and gunpowder, that are capable of rapid oxidation in the absence of air;
- Reactive metals such as lithium, sodium, potassium, magnesium, titanium, zirconium, uranium and plutonium;
- Metal hydrides;
- Chemicals capable of undergoing auto thermal decomposition, such as certain organic peroxidase and hydrazine.

8.4. SOME PHYSICAL AND CHEMICAL PROPERTIES

Table 10. HFC-236fa

Name	HFC-236fa
Global warming potential	9810
Ozone depletion potential	0
Chemical name	1,1,1,3,3,3-Hexafluoropropane
Formula	CF ₃ CH ₂ CF ₃
CAS number	690-39-1
Extinguishing concentration* (% of volume)	6.3
Boiling point (at pressure of 1 bar) (°C)	-1.4
Freezing point (°C)	-94
Critical temperature (°C)	124.9
Critical pressure (kPa)	3200
Density in liquefied form (at 25° C) (kg/m ³)	1360
Pressure of saturated vapors (at 25° C) (kPa)	272.4
LC ₅₀ (4 h inh.)	457 000
Toxicity AEL (ppm)	1000
Toxicity NOAEL (ppm)	90 000
Toxicity LOAEL (ppm)	105 000
Flammability	nonflammable substance
Form	liquefied gases
Color	colorless substance
Odor	slightly ethereal

*Extinguishing concentration determined for reference substance n-Heptane

Relation of the HFC-236fa vapour pressure from temperature:

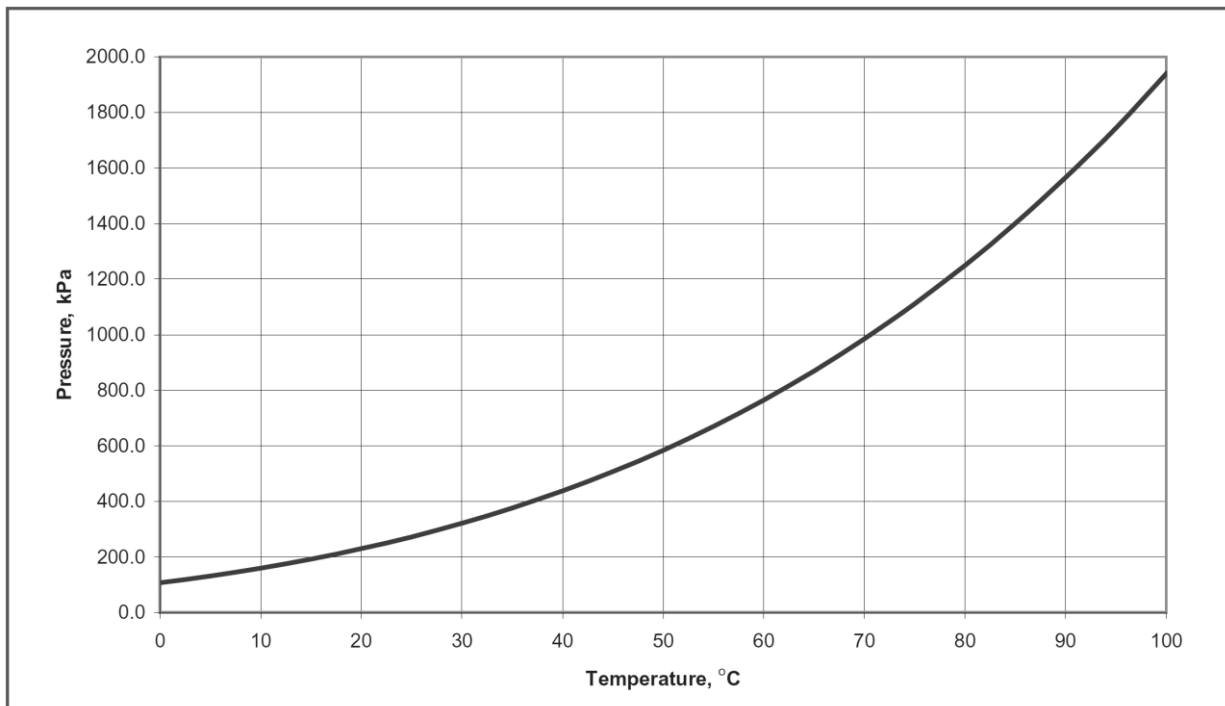

Detailed information on extinguishing agent is included in safety data sheet.

Table 11. HFC-227ea

Name	HFC-227ea
Global warming potential	3220
Ozone depletion potential	0
Chemical name	1,1,1,2,3,3,3-Heptafluoropropane
Formula	CF ₃ CHF ₂ CF ₃
CAS number	431-8-90
Extinguishing concentration* (% of volume)	6.7
Boiling point (at pressure 1 bar) (°C)	-16.34
Freezing point (°C)	-131
Critical temperature (°C)	101.75
Critical pressure (kPa)	2925.0
Density in liquefied form (at 25° C) (kg/m3)	1387.7
Pressure of saturated vapors (at 25° C) (kPa)	454.73
Toxicity LC50 (4 h inh.)	800 000
Toxicity AEL (ppm)	1000
Toxicity NOAEL (ppm)	100 000
Toxicity LOAEL (ppm)	150 000
Flammability	inflammable substance
Form	liquefied gas
Color	colorless substance
Odor	odorless

*Extinguishing concentration determined for reference substance n-Heptane

Relation of the HFC-227ea vapour pressure from temperature:

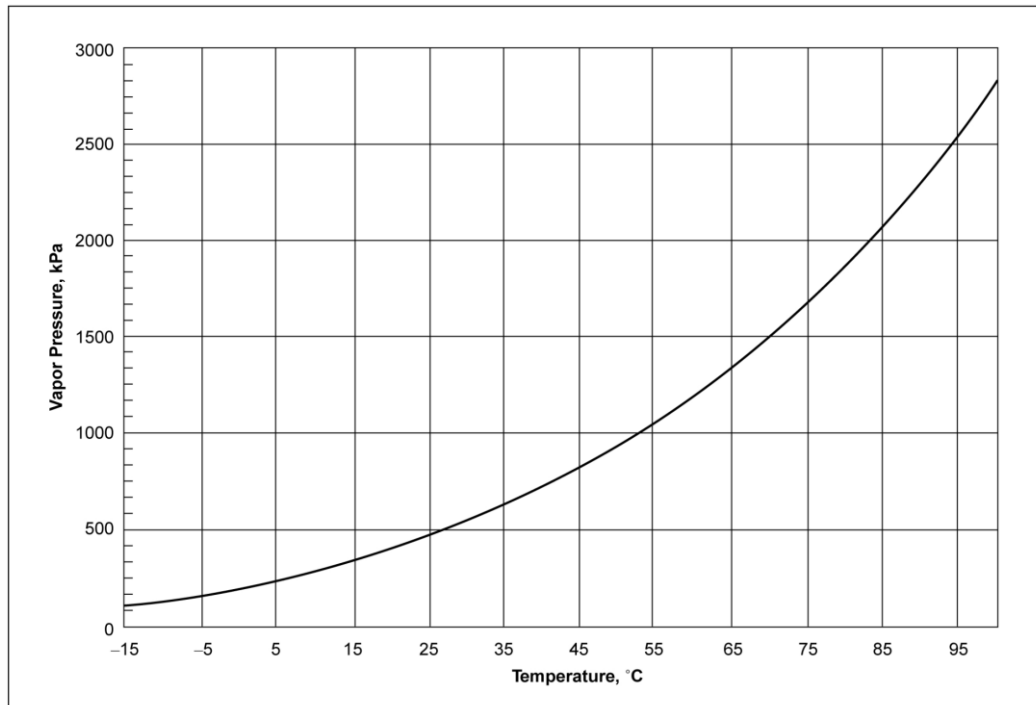

Detailed information on extinguishing agent is included in safety data sheet.

8.5. WARNINGS



Extinguishing agent under normal (atmospheric) pressure evaporates quickly. Do not breathe vapors. Exposure to high concentrations may cause health problems: a temporary loss of nerve activity, numbness, dizziness and confusion, loss of coordination, drowsiness, unconsciousness, irregular heartbeat, palpitations, depression, fainting, and weakness. Exposure to extreme concentrations of extinguishing agent may cause death without warning.



Extinguishing agent is heavier than air in a gaseous state. Accumulation in enclosed or low area may cause lack of oxygen and suffocation. After use of the system use natural or forced ventilation and do not enter thereafter.



Extinguishing agent in liquid form may cause frostbite upon contact with eyes. Avoid contact of liquid extinguishing agent with eyes. For installation, inspection, maintenance and repair of the system always use eye protection - wear appropriate protective glasses with side-shields.



Extinguishing agent in liquid form may cause frostbite upon contact with skin. When leak of liquid extinguishing agent from the system is detected use appropriate protective impervious working gloves.

NOTE:



Extinguishing agent is subject to thermal decomposition and forms toxic products - hydrogen halides after long exposure to high temperatures in the fire area. Avoid prolonged exposure of extinguishing agent to high temperatures. After fire is indicated take precautions to avoid prolonged exposure of extinguishing agent to high temperatures. After use of the system secure the area by natural or forced ventilation. Use the system only in permissible ways required by the manufacturer.

The most dangerous by-product of thermal decomposition of the extinguishing agent is hydrogen fluoride (HF). It is a gaseous substance, irritating and toxic, it is dissolved in water in mucous membrane creating hydrofluoric acid. Symptoms of HF exposure depend on the intensity and duration of exposure and are mainly as follows:

- Irritation of eyes and mucous membranes of the nose,
- Total respiratory irritation at a high concentrations,
- Irritation to the skin at high concentrations,
- Without medical assistance very high concentrations can cause death.

9. FIRST AID INSTRUCTIONS

In case of direct contact with extinguishing agent proceed as follows:

GENERAL INFORMATION:

In all cases of doubt, or when the symptoms persist, seek medical attention.

FOLLOWING INHALATION:

Move the person to fresh air and keep at rest in a position comfortable for breathing. If the person is not breathing or if breathing is irregular or breathing has stopped, administer artificial respiration or oxygen by trained personnel. Loosen tight clothing such as collar, tie, waistband, and belt. Do not administer adrenaline and its derivatives. Seek medical attention immediately.

FOLLOWING EYE CONTACT:

Carefully flush/irrigate with water for several minutes. If possible remove contact lenses, if they are inserted. Continue flushing. Seek medical attention.

FOLLOWING SKIN CONTACT:

Flush/irrigate the affected area with large amount of water. Do not use hot water. Remove contaminated clothing affected by extinguishing agent. If you experience frostbite, seek medical attention.

INGESTION:

Ingestion is not considered a potential route of exposure.

10. CERTIFICATION AND TESTING

Design documentation of the BlazeCut T Series was assessed and is in accordance with safety-technical requirements what is confirmed by expert opinion no. 3511/4/2018-04 issued by notified body:

Technická inšpekcia, a.s., Trnavská cesta 56, 821 01 Bratislava, Slovak Republic (NB 1354).

The BlazeCut T Series is in conformity with the design documentation confirmed by the abovementioned expert opinion and approved by the certificate no. 3511/4/2018-04 issued by notified body:

Technická inšpekcia, a.s., Trnavská cesta 56, 821 01 Bratislava, Slovak Republic (NB 1354).

The products are safe when the terms of use and technical requirements are observed.

Suitability, reliability and efficiency of the BlazeCut T Series was tested and confirmed by tests in accordance with technical requirements, certificate no. B-39-00926-14rev.1 was issued by qualified notified body:

Strojírenský zkušební ústav, s.p., Hudcova 424/56b, 621 00 Brno, Czech Republic.

A copy of the current certificates can be requested by emailing technical@blazecut.com

11. T SERIES CLAIMS AND WARRANTY

DISTRIBUTORS:

All orders should be checked within 14 days from receiving to make a valid claim of short supply or damage. Provide all information of the relevant order it relates to. Please refer to the BlazeCut claims form CR1216 for further details.

BlazeCut offer a 3 month window for the sale of the goods to a retail transaction. This effectively gives a 27 month warranty on T Series for distributors.

END USERS AND GENERAL PUBLIC:

BlazeCut Offer a two year warranty from the date of a retail sale. Proof of purchase is a definite requirement and a claim form is required to be completed.

BlazeCut optional components

12. PRESSURE MONITORING

12.1. PRESSURE SWITCH EAS AND FAS VERSION

Pressure Switch EAS and FAS version is a mechanical switch with one pre-set pressure value (switch point). When the pressure in the system drops below the switch point the pressure switch sends a signal to an Alarm Panel or an external device to perform the operation. The pressure switch is supplied with the cable connector and is also monitored by the panel for connectivity and faults.

Pressure Switch EAS and FAS version will send a signal when the pressure in the system decreases regardless of the cause, in case of fire or accidental activation and rapid decrease of pressure in the system which is below the pre-set value. If the cable is disconnected or damaged a fault signal will display on the panel.

Specifications

Material of body	galvanized steel		
Switch point	set to 1 bar		
Hysteresis	min. 0.3 bar / max. 1 bar		
Switching frequency	Max. 100 / min		
Power rating	Angular connector	All	Current
Resistive load AC-12, DC12	AC 250V	DC 24V	4A
Inductive load AC-14, DC14	AC 250V	DC 24V	2A
IP rating	IP65 with cable connector and seal		
Electrical outlet	DIN EN 175301-803 A		
Operation temperature	from - 30°C up to 100°C		
Thread	M10x1 (12.5 mm with O-ring and filter)		



Pressure Switch EAS and FAS version

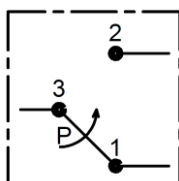

Method of closing the electrical circuit with the Pressure Switch EAS and FAS version on connectors



S1. Connect cable connector on pressure switch, seal must be mounted on the connector



S2. Use screwdriver to fasten. Max. Tightening torque 5 Nm



Connecting the cable connector to the pressure switch. The figures on right demonstrate the installation when using cable conduit.



Be aware of the danger posed by the protected device. When working in the vicinity of electrical equipment observe corresponding safety rules and instructions. Work on electrical installations may be performed only by qualified persons.

12.2. ELECTRICAL CABLES AND CONDUITS

For installation of Pressure Switch EAS and FAS version use a three core electrical cable for the TAP200 panel or a two core electrical cable to connect to an external device.



*Cable silicone
ACS102 and ACS104*

Part No.	Description	Comment
ACS102	Silicone cable, -60°C up to 180°C, UV stabilized, 2x0.75mm ² , up to 500 volt, per metre	For installations with high temperatures like in engine compartments.
ACS104	Silicone cable, -60°C up to 180°C, UV stabilized, 4x0.75mm ² , up to 500 volt, per metre	For installations with high temperatures like in engine compartments.

In case of installation in spaces with increased risk of damage due to mechanical interference use the cable conduit with conduit connector to protect the electrical cables.



Cable conduit ACC060



Conduit connector ACC001

Part No.	Description
ACC060	Cable conduit, Ø 18mm, -5°C to 60°C
ACC150	Cable conduit, Ø 18mm, -45°C to 150°C
ACC001	Conduit Connector between cable conduit and cable connector for Pressure Switch EAS and FAS version



Electrical connector with the cable conduit and conduit connector

NOTE

In case of malfunction or disconnection of the electrical of components (Pressure Switch EAS and FAS version, electrical installation) the system remains functional, these components are not necessary for its automatic activation in case of fire.

BlazeCut components Alarm Panel Kit KTAP200

1. BASIC INFORMATION ABOUT THE COMPONENTS

Commercial name: BlazeCut Alarm panel Kit TAPK200

Characteristics: Supply audio and visual warning upon actuation or fault.

Reference: For full details on the Alarm Panel TAP200 please see the APM200T manual.



KTAP200 includes the Alarm panel, Alarm panel mounting bracket, Fuse link, two 2 pin Deutsch plugs.

Main Features:

- Durable red anodized aluminum body suited for harsh environments
- IP65 rated
- Operation temperature from -40°C to +70°C
- Design allows for optional mounting; Flush mounted in a dash or the external bracket may be used to position the panel at any angle
- Universal power supply from 9V DC to 36V DC
- Electromagnetic compatibility (EMC) and immunity testing in accordance to E/ECE/324 and EHK 10-04
- Designed to minimize power consumption from external power source.

1.1. SPECIFICATION AND DESCRIPTION OF FUNCTION

The BlazeCut Alarm Panel TAP200 informs the persons of decrease in pressure in the system with a light and sound signal. It is connected to the BlazeCut Pressure Switch EAS and FAS version and reacts to its signal.

The Alarm Panel is connected to the system with electric cable ASC102. It is connected to electric power supply of the equipment. It is installed in the driver/operator area so that the unit is within the driver's reach and light and sound signals may be noticed under any circumstances.

AUTOMATIC FIRE SUPPRESSION SYSTEMS



The BlazeCut Alarm Panel TAP200 is especially suitable for use in connection with the systems installed into enclosures such as:

- Motor boats,
- Road vehicles (cars, SUVs, vans, recreational vehicles, minibuses, old timers, etc.),
- Off road vehicles (quads, small tractors, etc.)
- Electrical enclosures
- Generators, lighting towers etc.
- Stand-alone refueling stations

1.2. USE

The BlazeCut TAP200 can be used with all T Series systems only by using the additional component BlazeCut Pressure Switch EAS and FAS version.

The signaling unit can be connected directly to the pressure switch on all types of system BlazeCut T Series.



Install a use signaling unit of the system BlazeCut only with only with original supplied components. Do not replace anything in the system. Using components not approved by the manufacturer causes loss of warranty, may cause malfunction of the system and presents danger to life and health of persons.

1.3. INSTALLATION AND CONNECTING



Do not place the unit where it could affect the operation of the equipment or reduce operator visibility from the operating area.



Before interfering with electrical installation on the equipment, make sure that the power supply has been isolated.



Be aware of the danger posed by the protected device. When working in the vicinity of electrical equipment observe corresponding safety rules and instructions. Work on electrical installations may be performed only by qualified persons.

1. Place the Alarm panel of the system in the driver's cabin or operator's area, so that the unit is within the drivers or operator's reach and field of vision (light and sound signals in case of system activation).

Two methods for mounting include

For external installation use a stainless steel panel bracket supplied in a kit. The panel has holes for screws in two positions so the panel can be fixed vertically or angled depending on place of installation. The panel bracket can be installed to any surface and position and the panel can be rotated in 360° so it can be fixed in desired position. Use locking nut to fix the Alarm Panel to the bracket.

For dash in installation it is necessary to prepare round mounting hole with \varnothing 44 mm. Once the panel is inserted in the mounting hole use the locking nut to fix the panel in a dash from behind. The panel can be rotated 360° so it can be fixed in desired position.

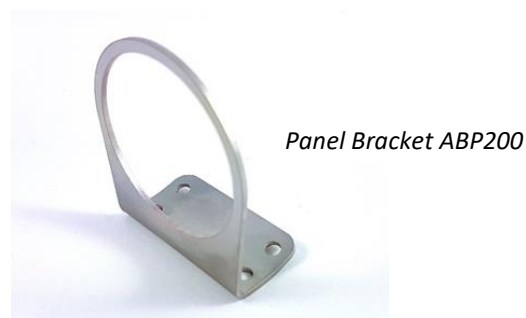
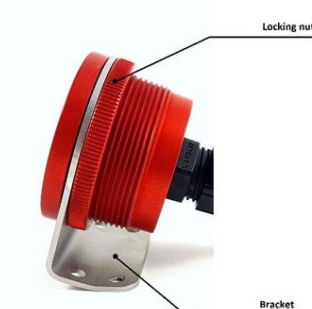

AUTOMATIC FIRE SUPPRESSION SYSTEMS



2. Protect the part of the electrical installation placed in the protected enclosure by using silicone cable or cable conduit with standard cable. There are two 2 pin Deutsch plugs provided in the Alarm Panel kit.
3. If possible place the cables from the pressure switch through the equipment to the signaling unit. Fasten the cables gradually to suitable firm parts of the equipment to ensure it will be protected from damage. Leave free area around the Alarm Panel so viewing is not obscured.
4. The Alarm Panel has its own fuse on the cable connected on the source of power. Please ensure you are using a suitable voltage source.
5. Ground the system to the frame of the vehicle.
6. Connect the Alarm Panel to the pressure switch as shown on the scheme of connecting, proceed in accordance with the instructions for connecting the pressure switch below.

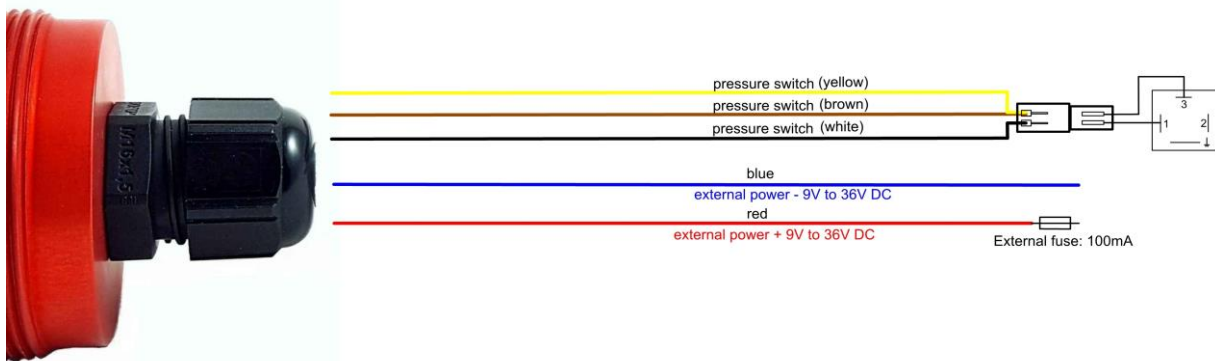

1.4. WIRING

The BlazeCut Alarm Panel TAP200 includes 1m output cable with 5 cores that are marked for correct installation.

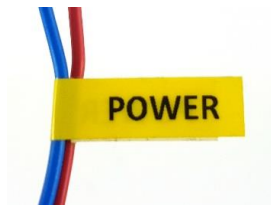

Red	+
Blue	-

To connect the power from the vehicle battery or other external power source.



Brown	+
White	-
Yellow	Monitoring

Pressure Switch circuit is used to connect the Pressure Switch EAS and FAS versions that provides pressure monitoring in the T Series system and sends a signal to the panel when the pressure drops below 1 bar or a fault signal if there is a fault with wiring.



The Alarm Panel is using external fuse rated 100 mA to provide additional protection in case of overloading. The fuse is installed between the panel wiring and external power source. The fuse is supplied with the protective case for external installation.

Wiring: The external fuse must be connected on the positive power wire.

1.5. ALARM PANEL TECHNICAL SPECIFICATIONS

- Material of body: red anodized aluminum
- Dimensions: Ø 50 mm, depth 30mm (excluding cable gland)
- Operation temperature: from -40°C to +70°C
- Ingress Protection: IP65 rated
- Operation voltage: from 9 volt DC to 36 volt DC
- External Cable: 1 m cable, 5 cores Ø 0,34 mm
- Sound power: 85 dB / 10 cm distance
- External fuse: 100 mA
- Maximum current draw at 24 V DC: 0.06 A
- Luminous intensity of LED lights: 1000 mcd / mA

1.6. DESCRIPTION OF FUNCTION OF THE SIGNALING UNIT

The signaling unit of system BlazeCut informs of decrease in pressure in the system with light and sound signals.

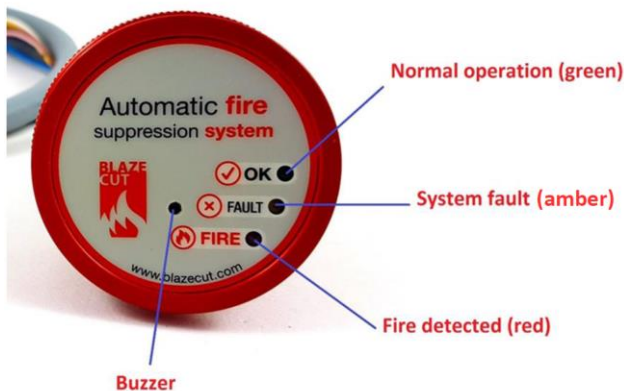

If the system signals activation the driver/operator must immediately stop the vehicle or shutdown the equipment and perform further measures according to operation instructions of the vehicle/equipment in order to protect the persons and property according to applicable legislation.

SERVICING OF THE ALARM PANEL

The TAP200 alarm panel is a sealed unit which has been designed and manufactured to be a maintenance free item. General external housekeeping is recommended over the life of the panel.

BlazeCut Signaling unit ASU001

1. BASIC INFORMATION ABOUT THE COMPONENTS

Commercial name: BlazeCut Signaling unit ASU001

Characteristics: Additional signaling unit for a BlazeCut Automatic Fire Suppression System.



1.1. DESCRIPTION

The Signaling Unit ASU001 informs the persons of decrease in pressure in the system with light and sound signal. It is connected to additional component of system BlazeCut Pressure Switch APS001 and reacts to its signal.

The Signaling Unit ASU001 is connected to the system with electric cables. It is supplied by external electric power source.

The Signaling Unit ASU001 is especially suitable for indoor use in connection with the systems installed such as electrical switchboards, fuse boxes, electrical supply sources, battery spaces, inductors, network installations, servers, audio-video equipment, etc.

1.2. USE

The BlazeCut Signaling Unit ASU001 can be used with all T Series systems only by using the additional component BlazeCut Pressure Switch EAS and FAS version.

The signaling unit can be connected directly to the pressure switch on all types of system BlazeCut T Series.



Install a use alarm unit of the system BlazeCut only with only with original supplied components. Do not replace anything in the system. Using components not approved by the manufacturer causes loss of warranty, may cause malfunction of the system and presents danger to life and health of persons.

1.3. INSTALLATION AND CONNECTING



Be aware of the danger posed by the protected device. When working in the vicinity of electrical equipment observe corresponding safety rules and instructions. Work on electrical installations may be performed only by qualified persons.

1. Place the signaling unit of the system so that it is visible and audible. Mount the unit firmly at a suitable place with screws.
2. If possible place the cables from the pressure switch to the signaling unit. Fasten the cables gradually to suitable firm parts of the construction. Leave free area around the alarm unit to later connect cables to cable connectors. Proceed accordingly when connecting to the power source.
3. Connect the alarm unit to the pressure switch as shown on the scheme of connecting, proceed in accordance with the instructions for connecting the pressure switch.

1.4. SIGNALING UNIT TECHNICAL SPECIFICATIONS

Material: self-extinguishing polycarbonate

Color: white

Weight of the unit (gross): ± 55 g

Dimensions: 80 x 80 x 30 mm

Connectors: 5
Operation voltage: 6 - 28 V DC
Current consumption: 4 mA nominal
Luminous intensity: 200 mCd
Sound power: 81 dB
Frequency: $\pm 3,6$ kHz

1.5. DESCRIPTION OF FUNCTION

The alarm unit of system BlazeCut informs of decrease in pressure in the system with light and sound signals:

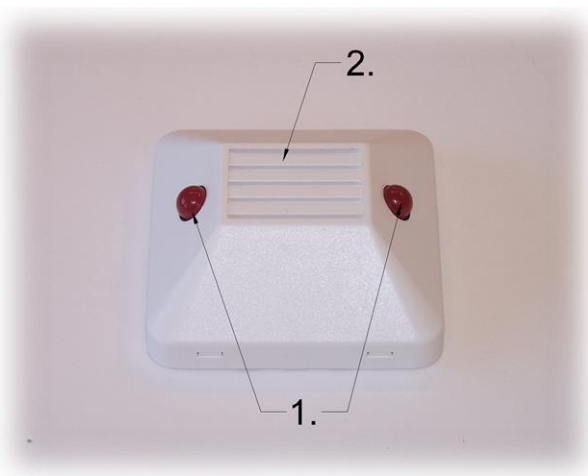
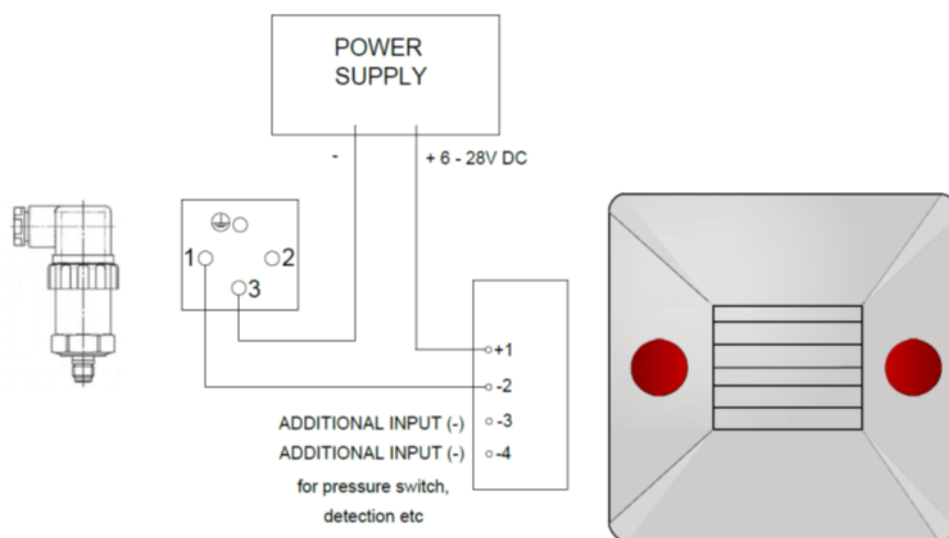

Fig. 9 Description of the signaling unit
1. Light-emitting diodes, flashes in case of alert
2. Opening for acoustic detector, makes sound in case of alert

1.6. WIRING DIAGRAM



The ASU001 can be mounted onto most types of mounting boxes using the universal mounting plate. Cable insertion is made through the back of the unit via the knockout at the sides of the housing. The wiring terminals allows up to four detectors to be connected. There are two switches to select if a flashing LED is preferred or a constant illumination at time of signal. This model can be connected to the BlazeCut AAP100 panel via the fire output wiring.

