



GT - SBLP 1500TP BATTERY LIFT



USER MANUAL

Operative Manual & Instructions for Use and Maintenance



GT - SBLP 1500TP Battery lift

Maximum Capacity: 1500 kg

Description:

This lift is uniquely designed for removal and installation of electric vehicle batteries. This product can also be used for removal and installation of various other components, such as: engines, transaxles, fuel tanks, suspensions, cradles, chassis system components, and future powertrains.



Explanation of Safety Signal Words

The safety signal word designates the degree or level of hazard seriousness.



DANGER: Indicates an imminently hazardous situation which, if not avoided, will result in death or serious injury.



WARNING: Indicates a potentially hazardous situation which, if not avoided, could result in death or serious injury.



CAUTION: Indicates a potentially hazardous situation which, if not avoided, may result in minor or moderate injury.

CAUTION: Used without the safety alert symbol indicates a potentially hazardous situation which, if not avoided, may result in property damage.

SAFETY PRECAUTIONS



WARNING: To prevent personal injury or equipment damage,

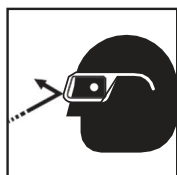

- Study, understand, and follow all instructions before operating this device.
- Wear eye protection that meets OSHA and ANSI Z87.1 standard.
- Only qualified personnel shall perform inspections and repairs to this lift.
- Before using lift, inspect the lift for bends, cracks, dents, elongated holes, or missing hardware. If damage is found, discontinue use.
- Use only those repair parts called out in the parts list in this document. Items found in the parts list have been carefully tested and selected.
- Do not exceed the rated capacity of lift or platform extension.
- Do not raise or lower lift with platform extended.
- Use only on a hard, level surface.
- Do not raise or move a load having a centre of gravity extending beyond the wheels. Tipping can result in personal injury.
- Do not move lift while a load is raised. Carefully and slowly move the load on inclines or around corners. Tipping can result in personal injury. Lower load completely before storage.
- Do not stand under a load supported by the lift.
- Secure component in place before removing it from the lift.
- No alterations shall be made to this product as this will void the warranty.
- Do not tamper with the hydraulic unit even if the battery lift doesn't work well.
- The fitting inserted on the cylinder has to be adjusted using a torque wrench. Do not overtighten the fitting too hard because it may damage the thread of the fitting.
- Handle the battery lift paying attention to the warnings on the packaging.

Pump

- Do not exceed the hydraulic pressure rating noted on the pump data plate or tamper with the internal high pressure relief valve. Creating pressure beyond the rated pressure can result in personal injury.

Galta S.r.l.

USt-IdNr. 04058700248

Via Lombardi, 19 - 36075 Montecchio Maggiore (VI)

Tel: +39-0444 493977 Fax: +39-0444 495999 www.galta.it mail: info@galta.it



- **Before replenishing the fluid level, retract the system to prevent overfilling the pump reservoir. An overfill can cause personal injury due to excess reservoir pressure created when cylinders are retracted.**

Galta S.r.l.

USt-IdNr. 04058700248

Via Lombardi, 19 - 36075 Montecchio Maggiore (VI)

Tel: +39-0444 493977 Fax: +39-0444 495999 www.galta.it mail: info@galta.it



DIMENSION AND CARATHERISTICS OF THE LIFTS

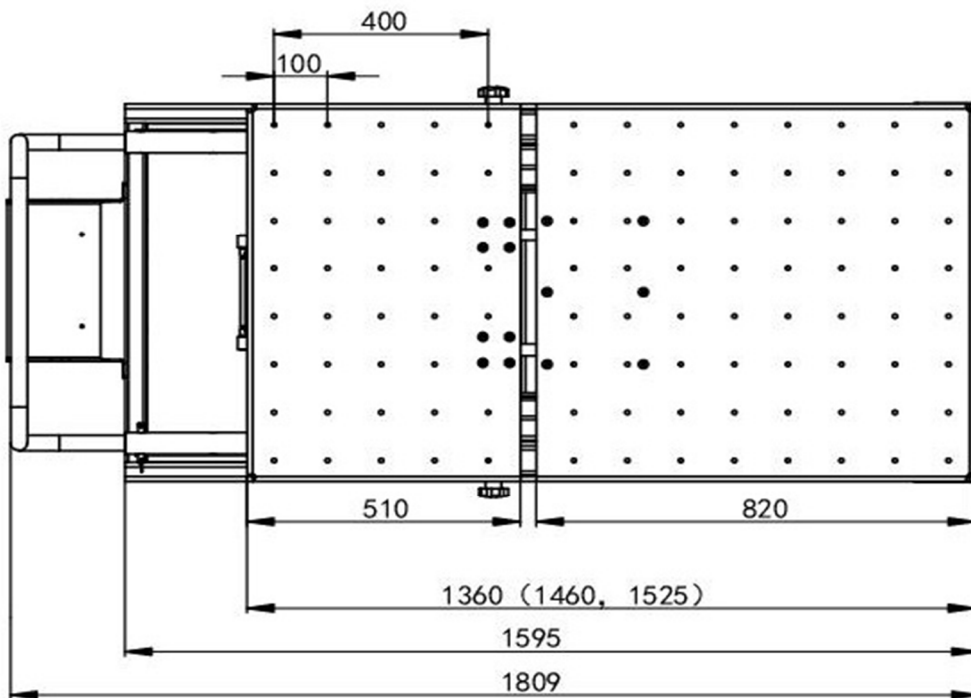
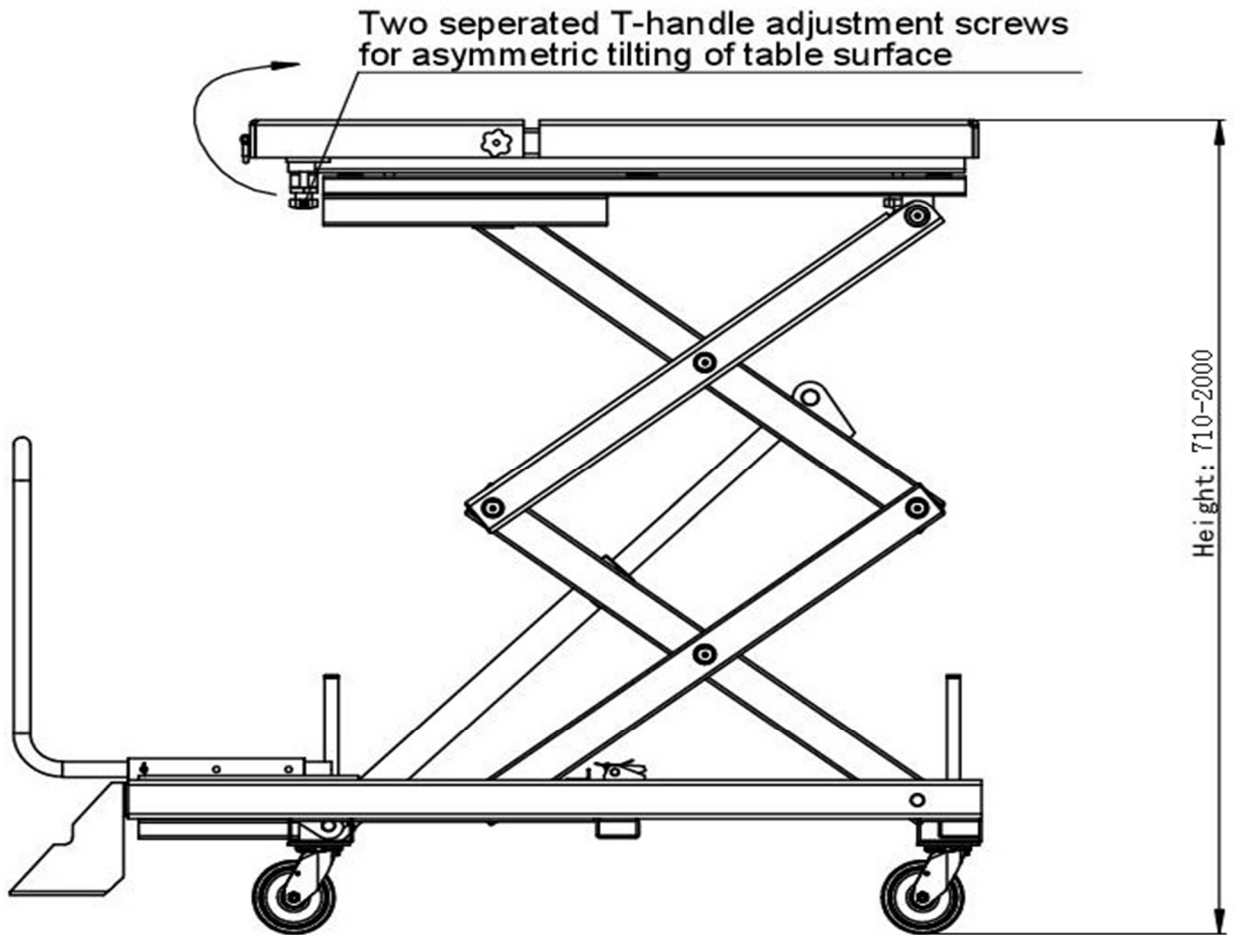

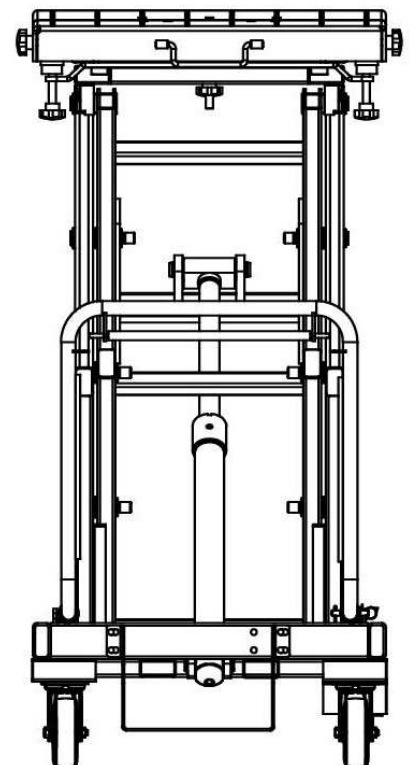
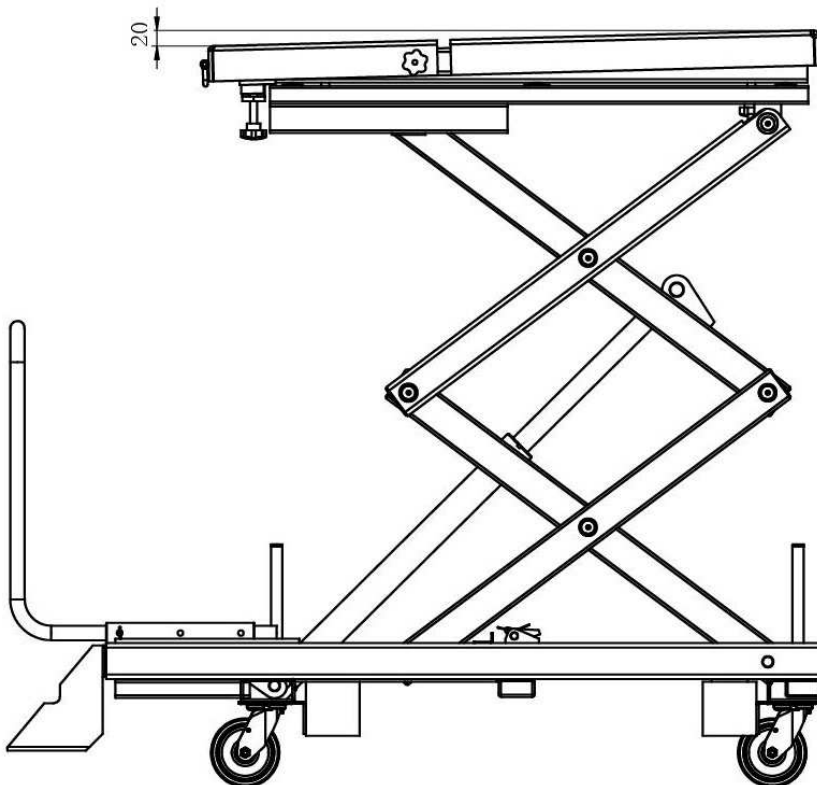
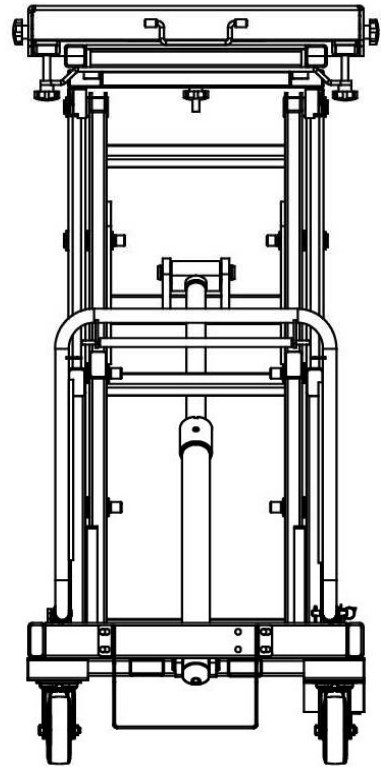
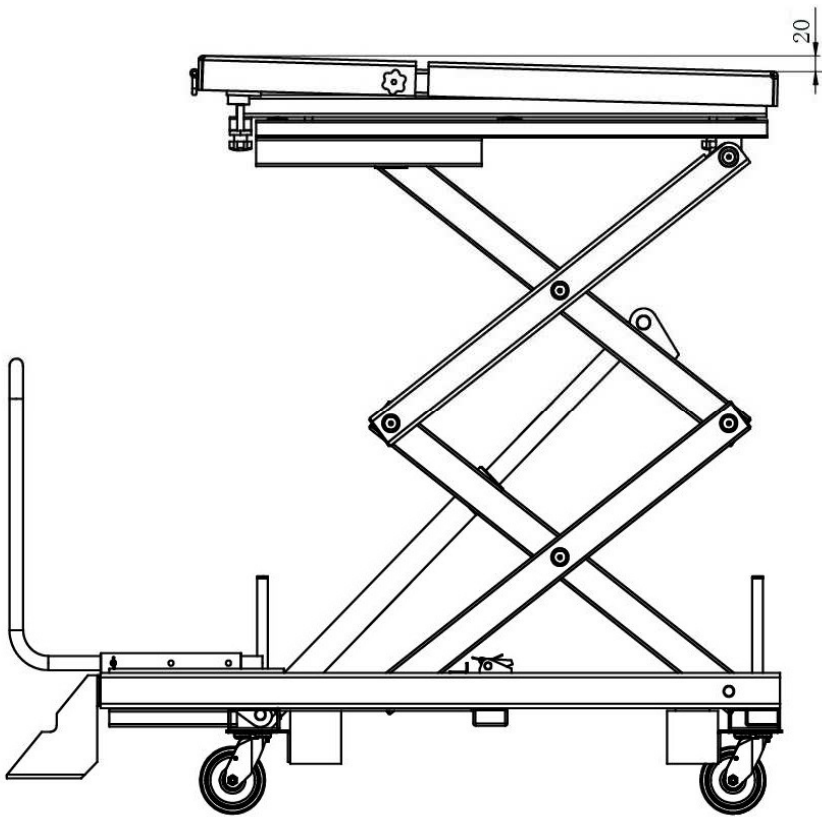

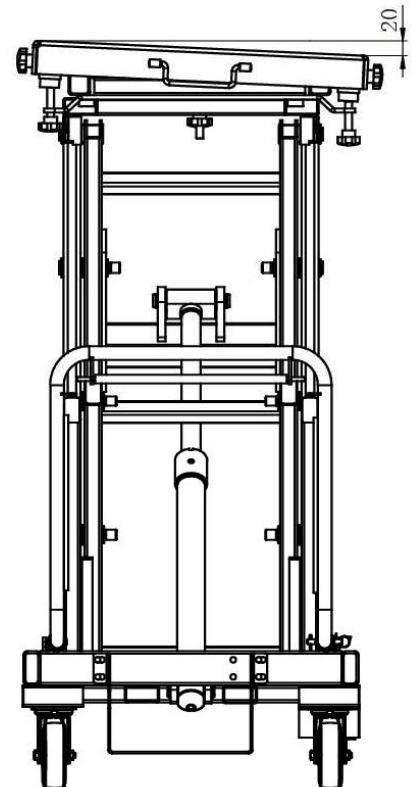
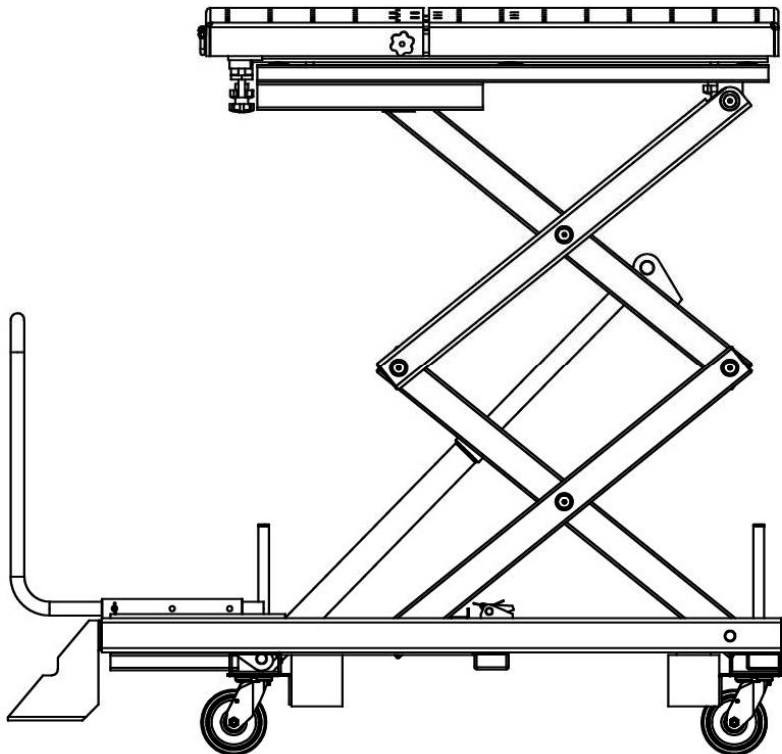
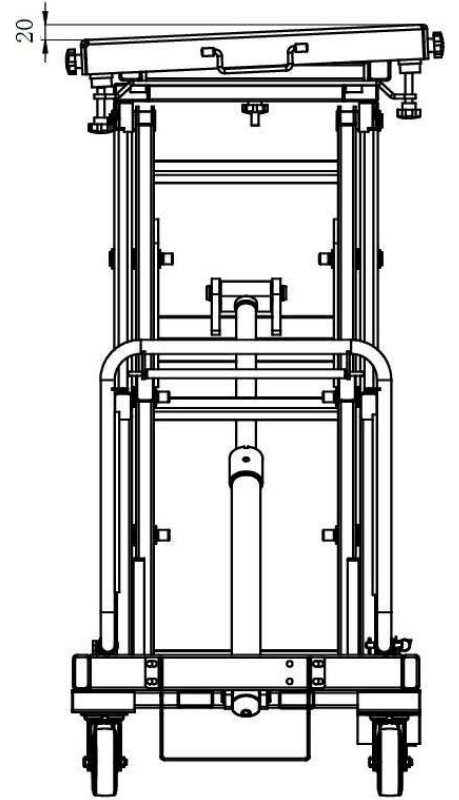
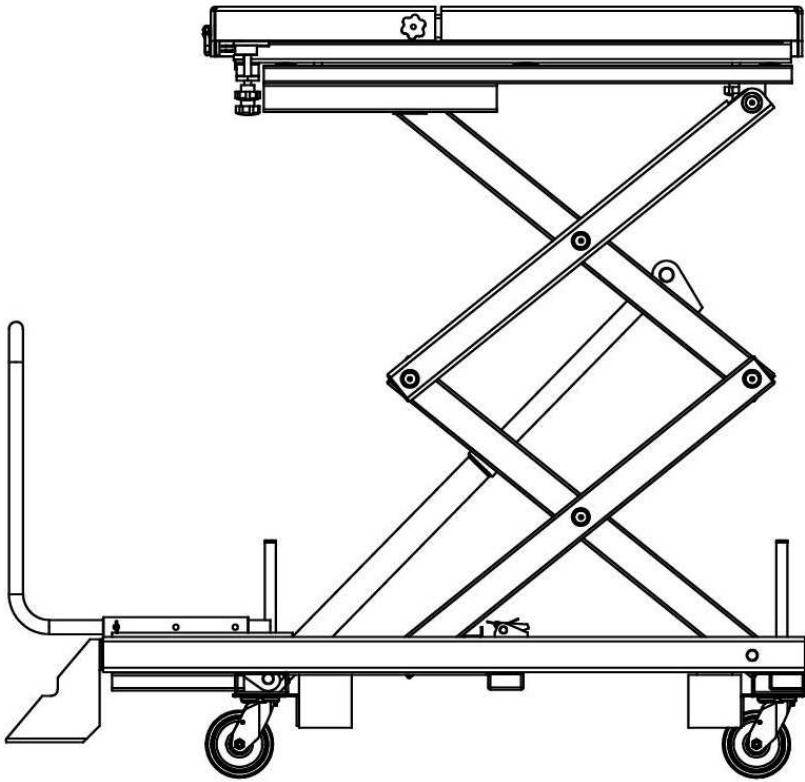

Can thrust

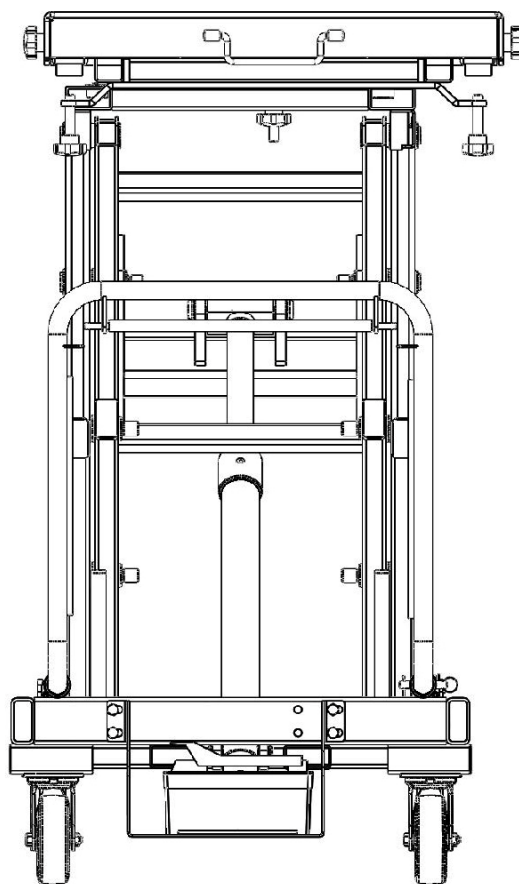
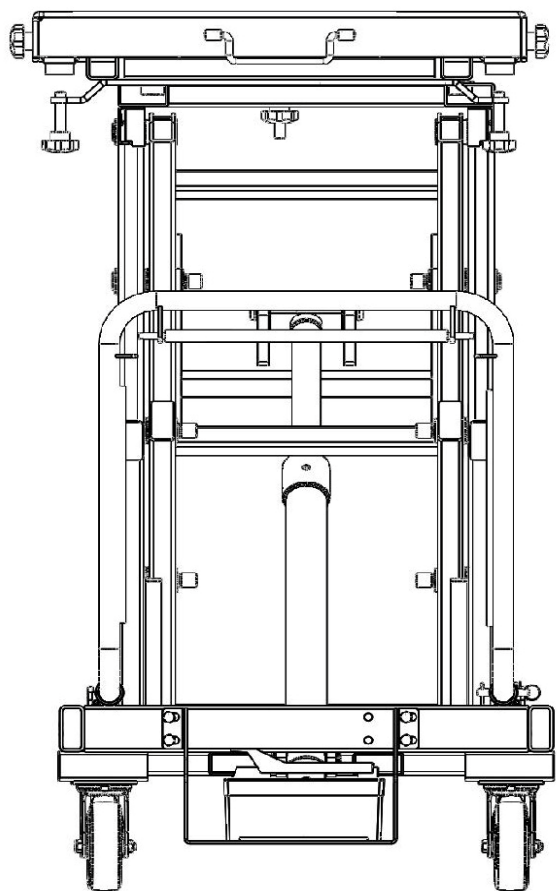

PREPARATION AND SET UP

Unpackaging

1. Cut shipping banding from carton and platform.
2. Install lift handle into base frame weldment and secure in place with cotterless hitch pins.
3. Remove the wood chocks from around the caster wheels.
4. Carefully roll the lift off the shipping pallet onto the floor.

Prepare the Air Pump for Operation

A. Pictogram Definitions

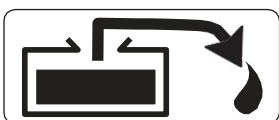

Activating the pump with the pedal end marked with this pictogram, the flow of fluids is directed out of the reservoir.

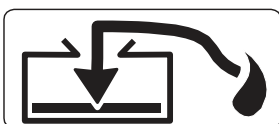

Activating the pump with the pedal end marked with this pictogram, the flow of fluids is directed back to the reservoir.



B. Cut shipping tie straps from air pump.

C. Air Supply Hook Up

1. Remove the thread protector from the air inlet of the pump. The pump's air inlet with quick coupling on one side and on the other side the internal threads M1/4G is fixed on the pump. Select and install the threaded fittings which are compatible with your air supply fittings. The air supply should be 600lt/min at 100 PSI (7 BAR) at the pump to obtain the rated hydraulic pressure. Air pressure should be regulated to between 50 PSI (3.5 BAR) and 140 PSI (9.5 BAR). A pressure of 100 PSI (7 BAR) is the recommended minimum. Secure your pump fitting to the air supply.
2. It is highly recommended to install an automatic airline oiler to the air supply as close to the pump as possible. Set the unit to feed approximately one drop of oil per minute into the system. Use SAE grade oil, ISO22

D. Priming the Pump Unit

Under certain circumstances it may be necessary to prime the air pump. To accomplish this, perform the following procedure:

1. Press the release end of the pedal while holding down the air intake valve with a flathead screwdriver. The air intake valve is located directly under the pedal in the area marked. The valve is depressed simultaneously with the area of the pedal during priming.

2. Allow the pump to cycle approximately 15 seconds.
3. Remove the screwdriver and press the  end of the pedal once more.
4. If the cylinder extends or pressure builds, the pump has been successfully primed. If the pump does not respond, repeat the procedure, jogging the air intake valve while holding the pedal in the  position

Filler/ Vent Cap



Air Intake Valve

Air Inlet (1/4-18 NP internal)

Picture 1 pneumatic pump



Picture 2 pneumatic pump with remote control

Galta S.r.l.

USt-IdNr. 04058700248



Via Lombardi, 19 - 36075 Montecchio Maggiore (VI)

Tel: +39-0444 493977 Fax: +39-0444 495999 www.galta.it mail: info@galta.it



FUNCTIONAL CHECK OF LIFT

Without external load applied to lift platform, fully raise and lower multiple times to ensure proper function of the hydraulic system and scissor components.

1. Press the end of the air pump foot pedal marked  to raise the lift platform until it stops at maximum extension.
2. Press and hold the end of the air pump foot pedal marked  to lower the lift platform until it reaches full collapse.
3. Ensure platform raises and lowers only when the air pump foot pedal is actively depressed by the operator.

Galta S.r.l.

USt-IdNr. 04058700248

Via Lombardi, 19 - 36075 Montecchio Maggiore (VI)

Tel: +39-0444 493977 Fax: +39-0444 495999 www.galta.it mail: info@galta.it



! **WARNING:** To prevent personal injury and/or equipment damage, if platform moves after air pump pedal is released, discontinue use and service immediately.

Preparation of Other Features

A. Platform Tilting Features

1. Turn forcing screws in/out fully to ensure proper function of platform tilting feature. See Figure 1 of “Fine Adjustment Tilting Feature” section.

B. Stabilization Feature

1. Insert leveller screws into sockets (approx. 5 turns). Leveller screws should not project above steel tube or contact platform underside when not in use. See Figure 2 of “Stabilization Feature” section.

C. Platform Sliding Extension Feature

1. Cut shipping banding securing platform halves
2. Retractspringplungerandextendplatformbypullingontablehandle.Ensurespring plunger engages at all three stop positions when the plunger is released.

OPERATING INSTRUCTIONS

Fine Adjustment Tilting Feature

The forcing screws shown in Figure 1 allow the user to finely tilt the platform to help remove or install vehicle components. This feature provides a total of two inches of tilt at the front of the platform which helps compensate for uneven shop floors, difficult fastener locations, etc. The forcing screws can be operated by either hand, or wrench or socket, depending on the applied load.

CAUTION: To prevent equipment damage, do not tilt the platform without the leveller screws in their lowest position as the platform might be driven into the screws

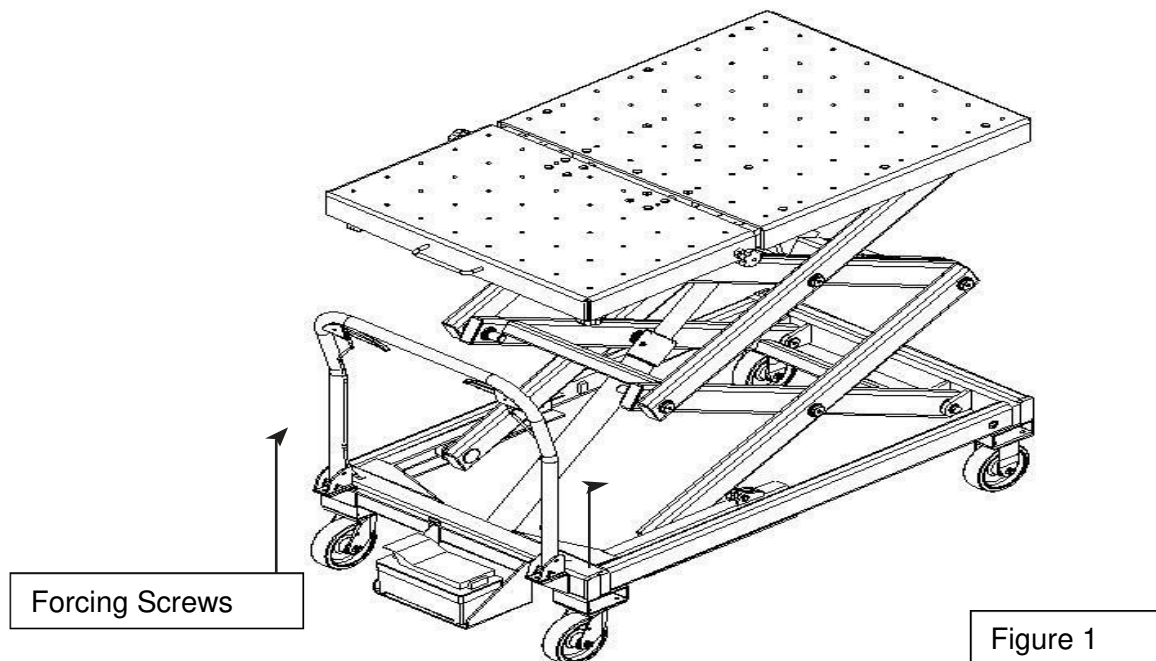

Stabilization Feature

If lift is to be used as a stationary work surface for servicing components, two leveller screws (see Figure 2) have been added to help stabilize the platform.

When the desired tilt or platform position has been reached, thread both leveller screws inward until they meet the bottom of the platform and tighten finger-tight only. This provides two extra points of contact for a more stable platform.

CAUTION: To prevent equipment damage,

- **Do not tighten the leveller screws with a wrench or ratchet.**
- **Do not tilt the platform if the leveller screws are not in their lowest position.**

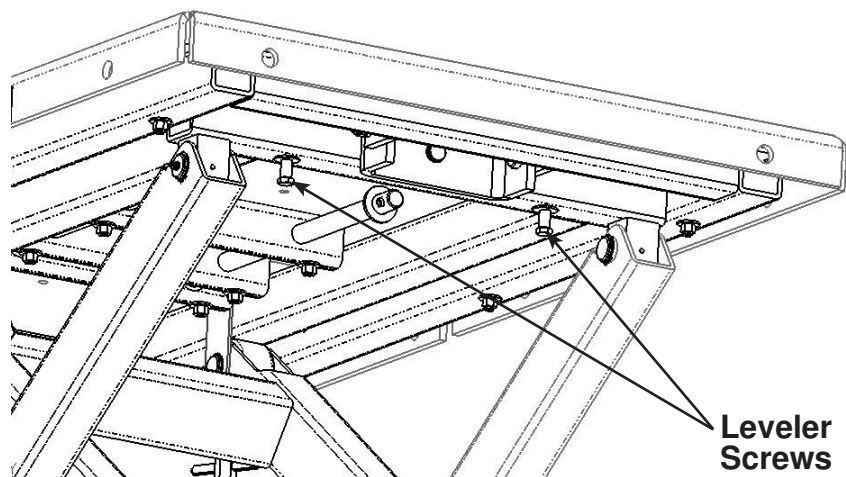

Figure 2

Platform Sliding Extension Feature

When the lift is to be used as a stationary work surface, the sliding platform extension may be used to facilitate the separation of powertrain components (i.e., engine and transmission). Retract spring plunger and pull-on Table Handle (See Figure 3) to extend sliding platform. Release spring plunger and slide platform extension until it locks into a stationary position.

Secure components to the platform with bolts and/or straps. Many M10 x 1.5 holes are provided in the platform top to thread bolts into. **CAUTION: To prevent damaging threads in the platform, do not torque bolts beyond 50 ft. lbs. (68 N•m).** Holes in the side edges of the platform are provided for securing straps.



WARNING: To prevent personal injury and/or equipment damage,

- **Always secure components to the platform with bolts and/or straps.**
- **Do not raise or lower lift with platform extended.**
- **Do not use the Platform Handle (located on the sliding platform) to move the entire lift.**

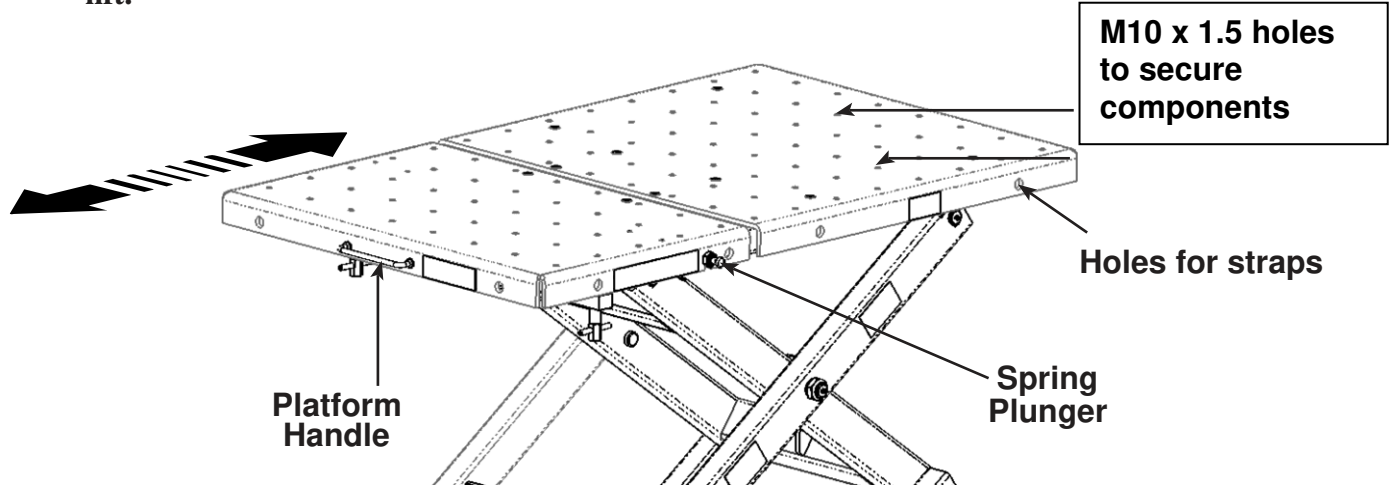

Galta S.r.l.

USt-IdNr. 04058700248



Via Lombardi, 19 - 36075 Montecchio Maggiore (VI)

Tel: +39-0444 493977 Fax: +39-0444 495999 www.galta.it mail: info@galta.it



Figure 3

Operating the Lift to Remove Components

1. Always follow the vehicle manufacturer's recommended service procedure for removal of the component.
2. Position the lift under the vehicle. Connect the air hose to the air pump.
3. Press the end of air pump foot pedal marked  to raise the lift to the load.
4. Remove any remaining bolts from the vehicle component.
5. Press the end of the air pump foot pedal marked  and lower the lift completely.
6. Move the lift and load out from under the vehicle.

Operating the Lift to Install Components

1. Position the lift under the vehicle chassis.
2. Align the component in the correct position and press the end of the air pump foot pedal  marked to raise the lift.
3. Always follow the vehicle manufacturer's recommended service procedure for installing the component.

INSPECTION AND MAINTENANCE



CAUTION: To prevent personal injury,

- **Only qualified personnel shall perform inspections and repairs to this lift.**
- Before each use, inspect the lift for bends, cracks, dents, elongated holes, or missing hardware. If damage is found, discontinue use.
- **Use only those repair parts called out in the parts list in this document. Items found in the parts list have been carefully tested and selected.**

Inspection

Before each use, an approved inspector must inspect the lift for bends, cracks, dents, elongated holes, or missing hardware. If damage is found, discontinue use.

Repair

When repairing the lift, use only those repair parts called out in the parts list in this document. Items found in the parts list have been carefully tested and selected.

Disposal

At the end of the useful life of the lift, dispose of the components according to all state, federal, and local regulations.

Preventive Maintenance

NOTE: 1 cycle = 1 complete raising and lowering of the lift platform.

Every 300 cycles or 6 months, whichever comes first:

A. Hydraulic Cylinder

1. Inspect for hydraulic fluid leaks.
 - Some oil accumulation on cylinder rod is normal and desired for proper function of the unit.
 - If fluid is escaping and puddling on the floor, the cylinder requires servicing.
2. Without load applied to platform, raise and lower lift multiple times. If cylinder pulses, sticks, or generally doesn't operate smoothly, unit needs servicing.

Preventive Maintenance continued

B. Hydraulic Fittings

1. Inspect for leaks.
 - Tighten fittings to stop leak.
 - Replace fittings if tightening does not stop leak.

C. Hose

1. Inspect and replace if found to contain cuts, cracks, or considerable surface wear.

D. Pump

1. Check hydraulic fluid level.
 - The fluid level should be added until the sign of the rod in the pump from the filler/vent cap with cylinder retracted. Replenish with hydraulic fluid (P/N 9637) through this port if needed.
2. Check pump reservoir for leaks due to damage to reservoir.
3. Raise and lower platform by operating air pump pedal. Ensure platform raises and lowers only when the air pump pedal is actuated.



WARNING: To prevent personal injury and/or equipment damage, discontinue use and service the unit immediately if platform moves after air pump pedal is released.

4. If platform moves slowly when raising, or pump seems to reciprocate faster than normal, install an automatic airline oiler prior to the pump.
 - When automatic airline oiler is installed, some oil discharge from pump exhaust is normal and indicates proper lubrication.

E. Lubrification

1. Use a grease gun to thoroughly apply grease at every location fitted with grease fitting (i.e., upper & lower rollers, casters, scissor & hydraulic cylinder pivot pins, etc.). Pump grease into fitting until only new grease can be seen escaping from joint. Wipe away excess.

F. Cleaning

1. Wipe dirt, debris, and grime from all surfaces using clean rag.

Every 3000 cycles or 24 months, whichever comes first:

A. Draining and Flushing the Pump Reservoir

1. Remove screws that fasten pump assembly to reservoir. Remove pump assembly from reservoir. Do not damage gasket, filter or safety valve.
2. Drain reservoir of all fluid and refill half full with clean hydraulic fluid **ISO22**. Rinse filter clean.
3. Place pump assembly back onto reservoir, and secure with two machine screws assembled in opposite corners of housing.
4. Run unit for several minutes. Use same method described in section titled “Priming the Pump Unit.”
5. Drain and clean reservoir once more.
6. Refill reservoir with hydraulic fluid **ISO22** and replace pump assembly (with gasket) on reservoir and install screws. Torque screws to 25-to-30-inch pounds (2.8 to 3.4 N•m).

B. Refilling the Pump Reservoir

If additional fluid must be added to reservoir, use only hydraulic fluid (p/n 9637; 215 SSU @ 100° F [38° C]). Clean entire area around filler plugs before adding fluid to reservoir. Remove filler plug, and insert a clean funnel with filter. The cylinder must be fully retracted and air supply disconnected when adding fluid to reservoir.

EXPLODED DRAWING AND LIST OF MACHINES

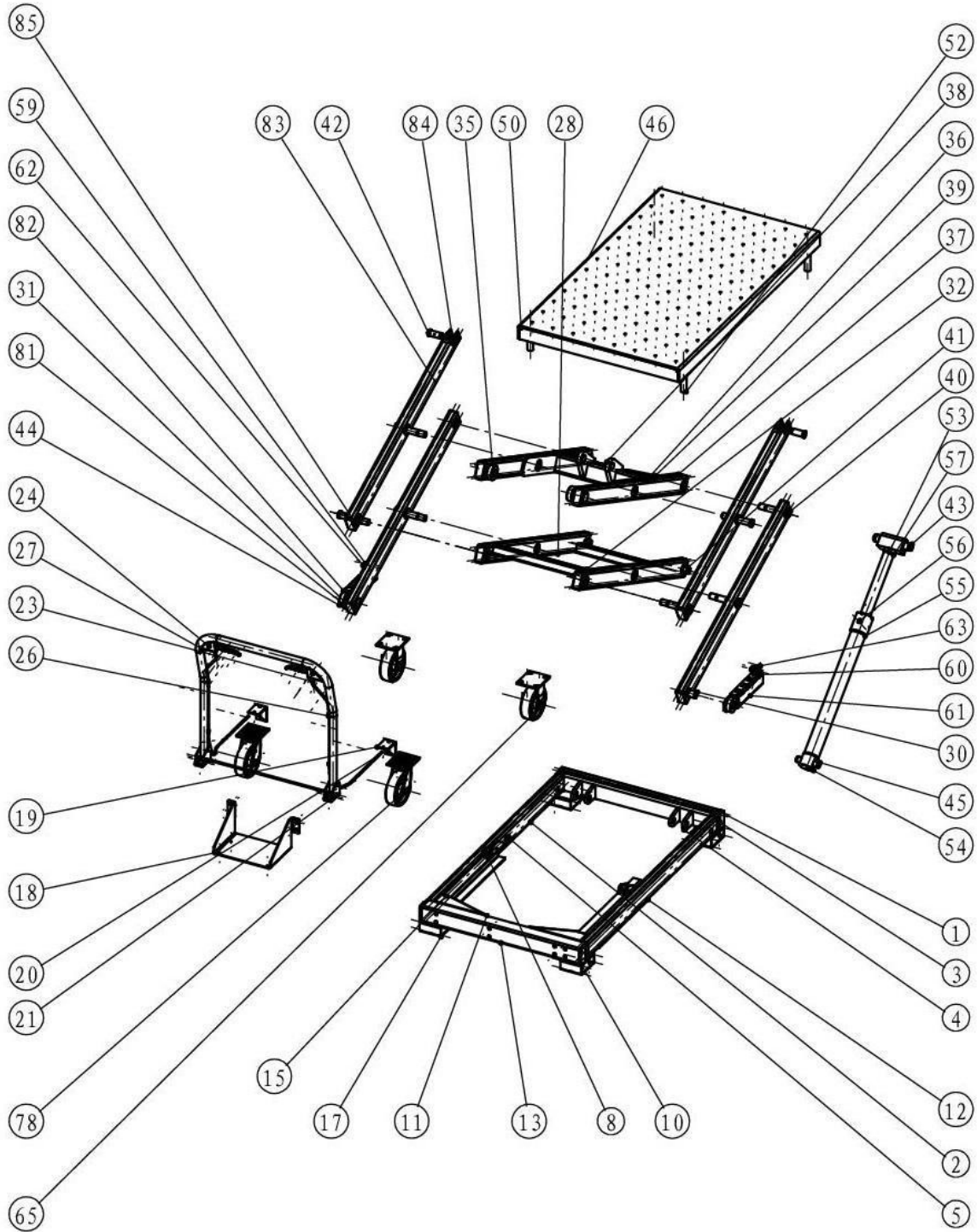

Exploded list:

No.	Name of parts	Qty
1	A-01-01Bottom frame torque tube	1
2	A-01-02Bottom frame torque tube	1
3	A-01-03Bottom frame stiffener	2
4	A-01-04lower trunnion	4
5	A-01-05Safety jaw block	2
6	A-01-02Bottom frame torque tube	1
7	A-01-06guide rail	1
8	A-01-07Safety claw support	4
9	A-01-09Caster mounting plate	1
10	A-01-10Bottom frame plate	4
11	A-01-11Bottom frame support	2
12	A-01-12reinforce of guide rail	2
13	A-01-13Air pump mounting plate	1
14	A-01-14lower trunnion of cylinder	2
15	A-01-06guide rail	1
16	A-01-09Caster mounting plate	2
17	A-01-09Caster mounting plate	1
18	A-03air pump base	1
19	A-04- 01Armrest mounting seat assembly 1	2
20	A-04- 02Armrest mounting seat assembly 2	2
21	handle	1
22	handle	1
23	cable	1
24	handle	1

25	cable	1
26	A-08-01 wire tube	4
27	A-08-02 handle fixed base	2
28	B-01-01 arm section	6
29	B-01-02 The connecting rod bushing	16
30	B-01-03 shaft of roller	2
31	B-01-0 Connecting rod seal plate	14
32	B-02-01 connecting rod	2
33	B-03-01 Upper outer connecting rod main body	1
34	B-03-02 Upper outer connecting rod reinforcement sleeve	2
35	B-04-01 shaft of roller	2
36	B-04-02 Upper ear support	1
37	B-04-03 Inner connecting rod stiffener	2
38	B-04-04 Oil cylinder upper ear	2
39	B-04-05 Upper inner connecting rod stiffener	2
40	B-05 shaft of arm section	8
41	B-06 The trunnion	2
42	B-07 The trunnion	2
43	B-08 Upper support hinge shaft of oil cylinder	1
44	B-09 roller	4
45	B-10 Lower support hinge shaft of oil cylinder	1
46	C-01-01 main platform	1
47	C-01-02 Platform girder	2
48	C-01-03 platform crossbeam	2
49	C-01-04 upper trunnion	2
50	C-01-05 the side plate	2

51	C-01-06guide rail	2
52	C-01-07limit rod	4
53	D-02Piston rod earrings	1
54	D-01-04cylinder bottom	1
55	D-01-03cylinder tube	1
56	D-01-02cylinder cover	1
57	D-01-01plunger pole45-695	1
58	D-01-05guide block	1
59	E-01safety claw	2
60	E-02-01Safety rack fixing plate	1
61	E-02-02Main body of safety rack	1
62	E-03shaft of safety claw	2
63	torsional spring	1
65	oriented wheel	2
78	universal wheel	2
80	Colson-4.06109. 939.step_5500 0.23	2
81	E-02-01E-02-01fixed plate of safety teeth	1
82	E-02-02E-02-02main body of safety teeth	1
83	B-03-01Upper outer connecting rod main body	1
84	B-03-02Upper outer connecting rod reinforcement sleeve	2
85	B-01-02The connecting rod bushing	2

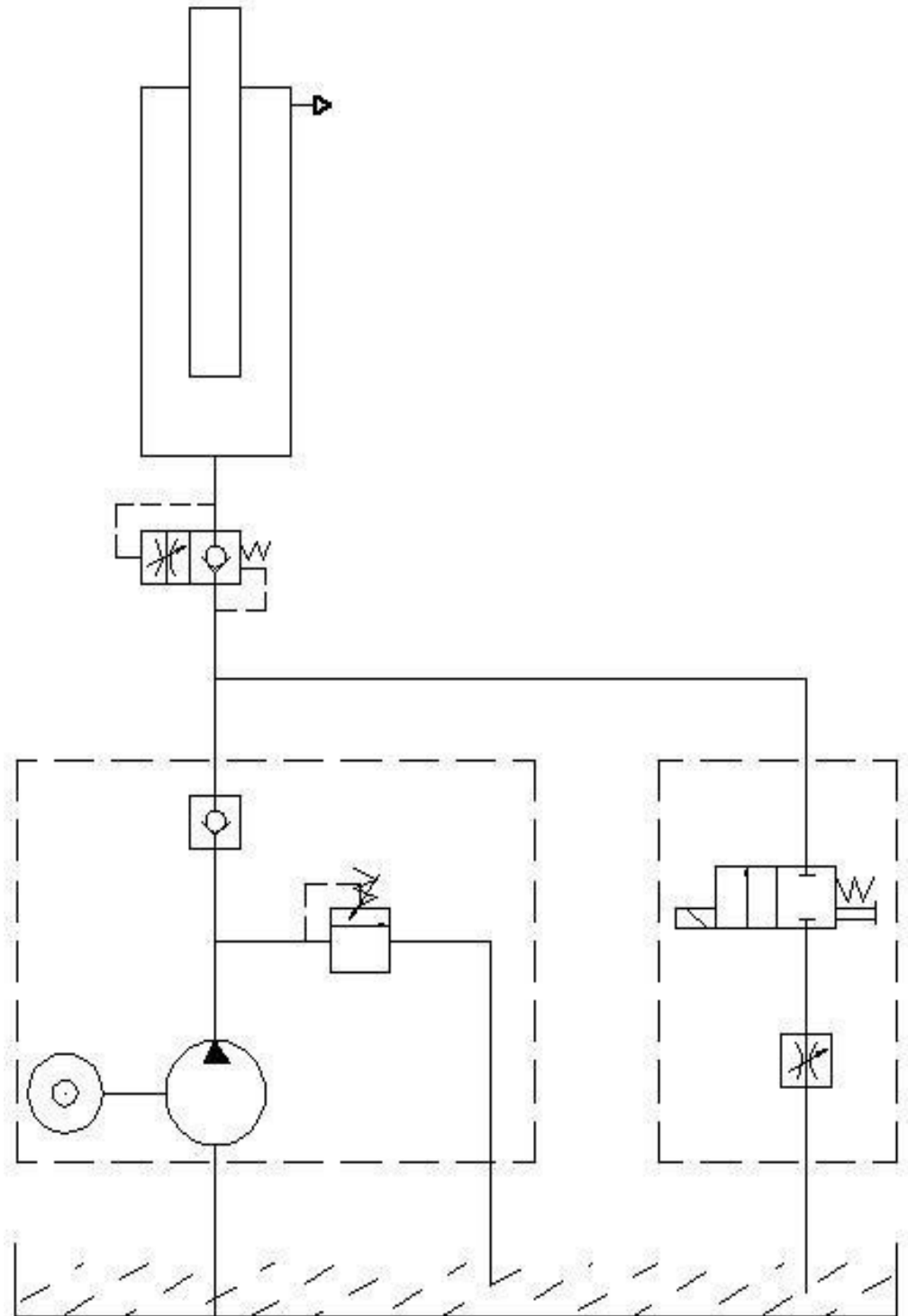

Machine type	GT-SBSP 1500TP	GT-SBSP 1500TP-TEL
Drive mode	Pneumatic hydraulic	Pneumatic hydraulic
Rated lift weight	1500kg	1500kg
Host lifting height	2000mm	2000mm
Initial height of the platform	710mm	710mm
Platform length	1360-1525mm	1360-1525mm
Platform width	787mm	787mm
Lifting Time	about 90s	about 90s
Lowering time	about 30s	about 30s
Overall width	787mm	787mm
Overall length	1659mm	1659mm
Overall Weight	441.5kg	441.5kg
Hydraulic oil	1.5l is equivalent to 20# wear-	1.5l is equivalent to 20# wear-
Working temperature range	5-40°C	5-40°C
Working humidity range	30-95%	30-95%
Noise level	< 90db	< 90db
Installation height	Sea dial ≤1000m	Sea dial ≤1000m
Storage temperature	-25°C~55°C	-25°C~55°C

2.2 Main parameters of pneumatic pump

Input pressure	0.7-1.0 Mpa
Output pressure	0-30 Mpa
preset pressure	25 Mpa
flow	4.5-0.6 L/min