



# TW 260

Clear Floor Two Post Lift  
Lifting Capacity 6.000 kg

twinbusch.de



## Installation, Operation and Parts Manual



**Please read this entire manual carefully and completely  
before installation or operation of the lift.**

Twin Busch GmbH | Amperestraße 1 | D-64625 Bensheim  
Tel.: +49 (0) 6251-70585-0 | Fax: +49 (0) 6251-70585-29 | info@twinbusch.de

**Table of contents**

- 1. General information ..... 1**
- 2. Identification of the user manual ..... 1**
- 3. Technical specification ..... 1**
- 4. Modification of the product ..... 1**
- 5. Security related information ..... 2**
  - 5.1. Safety instructions ..... 2
  - 5.2. Warnings and symbols ..... 2
  - 5.3. Safety equipment ..... 4
  - 5.4. Monitoring and testing of safety devices ..... 4
- 6. Compliance with the product ..... 4**
- 7. Technical specification ..... 5**
  - 7.1. Machine description ..... 5
- 8. Installation of the lift ..... 5**
  - 8.1. Precautions before installation ..... 5
    - 8.1.1. Required tools and equipment ..... 5
    - 8.1.2. Control list (Packing list) ..... 5
  - 8.2. Ground conditions ..... 6
  - 8.3. Assembly instructions ..... 6
  - 8.4. Checkpoints after installation ..... 12
- 9. Commissioning ..... 13**
  - 9.1. Safety precautions ..... 13
  - 9.2. Description of the control unit (control box) ..... 13
  - 9.3. Flow chart for operation ..... 14
  - 9.4. Operation manual ..... 15
    - 9.4.1. Raise the lift ..... 15
    - 9.4.2. Lowering the lift ..... 15
  - 9.5. Emergency lowering function in case of power failure ..... 15
- 10. Troubleshooting ..... 17**
- 11. Maintenance ..... 17**
  - 11.1. Daily inspection and maintenance of the lift elements before use ..... 18
  - 11.2. Weekly inspection and maintenance of the lift ..... 18
  - 11.3. Monthly inspection and maintenance of the lift ..... 18



## Manual 2-post lift TW 260

11.4.	Annual inspection and maintenance of the lift elements .....	18
<b>12.</b>	<b>Behavior in the event of a malfunction .....</b>	<b>19</b>
<b>13.</b>	<b>Appendix .....</b>	<b>20</b>
13.1.	Dimensions of the lift .....	20
13.2.	Foundation requirements and working area .....	21
13.3.	Hydraulic system .....	24
13.4.	Schematics.....	25
13.5.	Detailed drawing and parts description of the lift .....	29
13.6.	Spare part list.....	35

### Further appendix:

- **Operating instructions for lifts**
- **EU-Declaration of Conformity**

## 1. General information

The Heavy-Line model series is probably the most widely used lift series on the market. The model variants allow with their high load capacity of 6000 kg and the very large swivel range of the support arms easy lifting of small cars, to SUVs, large sedans and sports cars as well as maxi transporters with short, medium and long wheelbase. Due to their wide passage widths, this is also perfectly suitable for lifting wide vehicles with structure, such as. Motorhomes and caravans, vehicles with sales set up or ambulances. For lifting and working on very tall vehicles, such as camper with Alcove, we recommend the TW 260. The Heavy-Line model series has grown to the high performance requirements of a professional workshop and has very extensive standard equipment such. Turntable with double thread, flat drive-over plate (if not barrier-free), column protection cover, motor cover, 230 V socket directly on the control box and the included plug adapter elevations and matching convenient plug adapter brackets.

## 2. Identification of the user manual

### Manual TW 260

from Twin Busch GmbH,  
Ampèrestraße 1,  
D-64625 Bensheim

Phone: +49 6251-70585-0  
Fax: +49 6251-70585-29  
Internet: [www.twinbusch.de](http://www.twinbusch.de)  
Email: [info@twinbusch.de](mailto:info@twinbusch.de)

Status: -00, 22.11.2019

File TW 260\_2-post lift\_manual\_en\_00\_20191122.pdf

## 3. Technical specification

Power supply (3-Phase)	400 V / 50 Hz
Fuse protection	C 16A (delay-action fuse)
Load capacity	6.000 kg
Degree of protection of enclosure	IP 54
Time to raise	ca. 50 sec.
Time to lower	ca. 30 sec.
Net weight	1090 kg (2403 lbs)
Noise	< 70 db
Working environment	temperature: -15°C (5F) to +40°C (104F)
	rel. humidity: 30% to 85%

Chart 1: technical specification

## 4. Modification of the product

The improper use, as well as not agreed with the manufacturer modifications, conversions and attachments of the lift and all its components are not allowed. In the event of improper installation, operation or overloading, the manufacturer will assume no liability. Similarly, the CE certification and the validity of the report expire due to improper use.

If changes are required, contact your dealer or the competent staff of Twin Busch GmbH beforehand (see: 2. Identification of the user manual)

### 5. Security related information

Read the operating instructions carefully before operating the lift. Keep the instructions for reference. Follow the instructions carefully to achieve the best performance of the machine and to avoid personal injury.

Unpack all parts and use the packing list to check if all components are present.

Check all connections and components thoroughly for damage. The lift may only be put into operation if it is in a safe operating condition.

#### 5.1. Safety instructions

- Do not install the lift on a paved surface
- Read and understand the safety instructions before operating the lift
- Never leave the control unit while the lift is moving
- **Fern** Keep hands and feet away from moving parts. Pay particular attention to your feet when lowering
- The lift must only be operated by trained personnel
- Uninvolved persons are not allowed near the lift
- Wear suitable work clothing
- The environment of the lift should always be kept free from interfering objects
- The lift is designed to lift the entire vehicle which does not exceed the approved maximum weight
- Always ensure that all safety precautions have been taken before working near or under the vehicle
- **Never remove safety-related components from the lift.**
- Do not use the lift if safety-related components are missing or damaged
- Under no circumstances move the vehicle or remove heavy objects from the vehicle, which could cause significant weight differences while the vehicle is standing on the lift
- Always check the mobility of the lift to ensure its efficiency. Ensure regular maintenance. If an irregularity occurs, stop working with the lift immediately and contact your dealer
- Lower the lift completely when not in use. Do not forget to interrupt the power supply
- If you do not use the lift for a long period, then:
  - a. Disconnect the lift from the power source
  - b. Empty the oil tank
  - c. Lubricate the moving parts with hydraulic oil

**Caution: To protect the environment, dispose of the unused oil accordingly**

- **For safe lifting of transporters, it is essential to use the optional special adapter. These can be found at: [www.twinbusch.de](http://www.twinbusch.de)**

#### 5.2. Warnings and symbols

All warnings are clearly visible on the lift to ensure that the user uses the device in a safe and secure manner.

The warnings must be kept clean and replaced if they are damaged or missing.

Please read the signs carefully and memorize their meaning for future operations.

	Before use instructions and safety instructions, read carefully!		Operating the lift only by specialist staff!
	Repairs and maintenance only by qualified personnel. Never put safety equipment out of operation!		Only specialist staff allowed in the vicinity of the lift!
	Always keep escape routes clear!		The presence of persons (when lifting or lowering) under the lift is prohibited!
	Pay attention to your feet when lowering! Crushing hazard!		Climbing the lift is strictly prohibited!
	Note the pickup points of the vehicle manufacturer!		After a short lifting, check the vehicle for a secure fit!
	Do not exceed the specified load capacity!		When installing or removing heavy parts, the vehicle can tip over!
	Never try to load only one side of the lift!		Protect the lift from moisture! Electrical connections must be absolutely dry!
	Avoid strong shaking on the vehicle		ATTENTION! Electric voltage!

Chart 2: Safe condition signs

### 5.3. Safety equipment

For safe operation of the lift, it is equipped with the following safety features \*):

- Safety locks
- Throttle valve in hydraulic line
- limit switches
- support arm locks
- Devices against jamming and crushing (shaft protection, foot deflector)
- Synchronization ropes

\*) depending on the type of lift

### 5.4. Monitoring and testing of safety devices

- |                         |  |
|-------------------------|--|
| - Safety locks          | function test, when lowering the lift, safety locks must engage and stop the downward movement                         |
| - Throttle valve        | fixed throttle, an optical check by user not possible  |
| - Limit switches        | if the limit switch is pressed, the motor stops or cannot start  |
| - Support arm locks     | when the support arms are raised, the support arm lock must engage and remain securely engaged when loaded on the side |
| - Safety devices etc.   | the safety devices must be installed, ready to work and undeformed   |
| - Synchronization ropes | check condition  |

### 6. Compliance with the product

The TW 260 2-post lift is CE certified and complies with the Machinery Directive 2006/42 / EC and complies with EN 1493: 2010, EN 60204-1: 2006 + A1: 2009 and EN ISO 12100: 2010 standards. See also the EU Declaration of Conformity at the end of the instructions for use.



## 7. Technical specification

### 7.1. Machine description

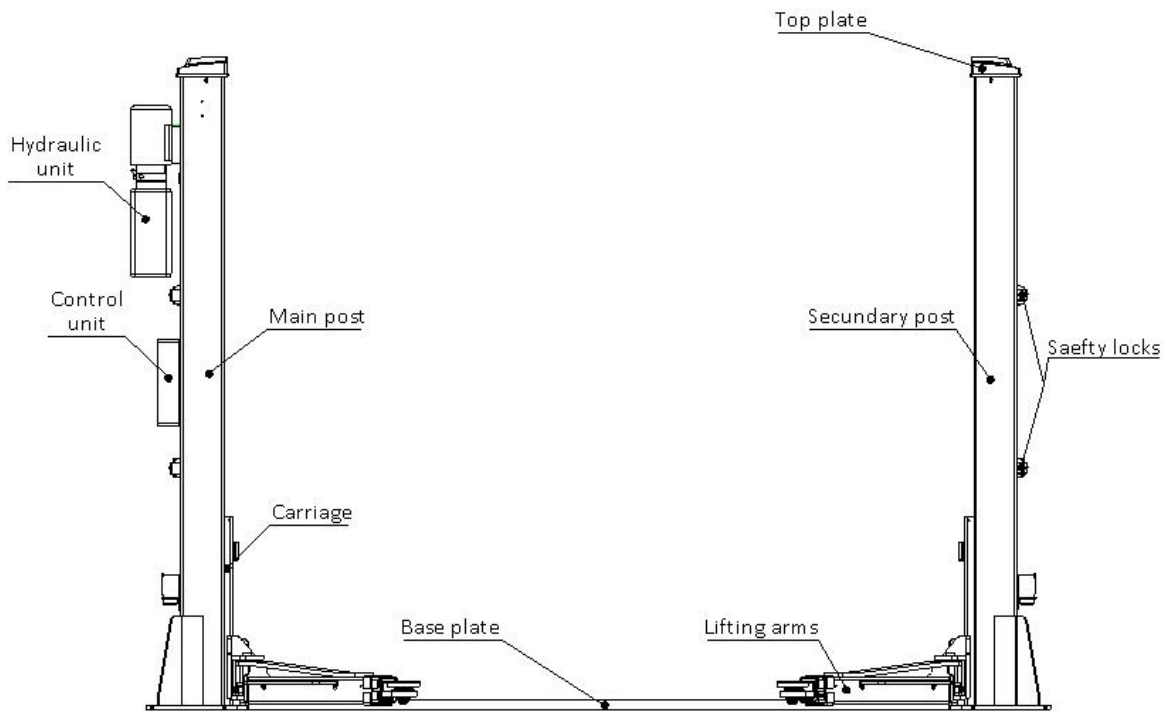

Figure 1: Description TW 260

## 8. Installation of the lift

### 8.1. Precautions before installation

#### 8.1.1. Required tools and equipment

- Suitable lifting tool for bulky and heavy components
- Hammer, pincers
- Cross and slotted screwdrivers
- Set of hexagon wrenches
- Wrench attachments and open-end wrenches
- Impact drill
- Hydraulic oil HLP 32

#### 8.1.2. Control list (Packing list)

Unpack all components of the lift and check the completeness of all components with the help of the packing list.



## 8.2. Ground conditions

The lift must be installed on a solid foundation with a compressive strength of more than  $3\text{kg} / \text{mm}^2$ , a flatness of less than 5mm and a minimum thickness of 250mm. Detailed information can also be found in the corresponding foundation plan on our homepage at [www.twinbusch.de](http://www.twinbusch.de).

Note: If a new concrete floor is poured, it must be at least 28 days rest until a lift can be installed.

## 8.3. Assembly instructions

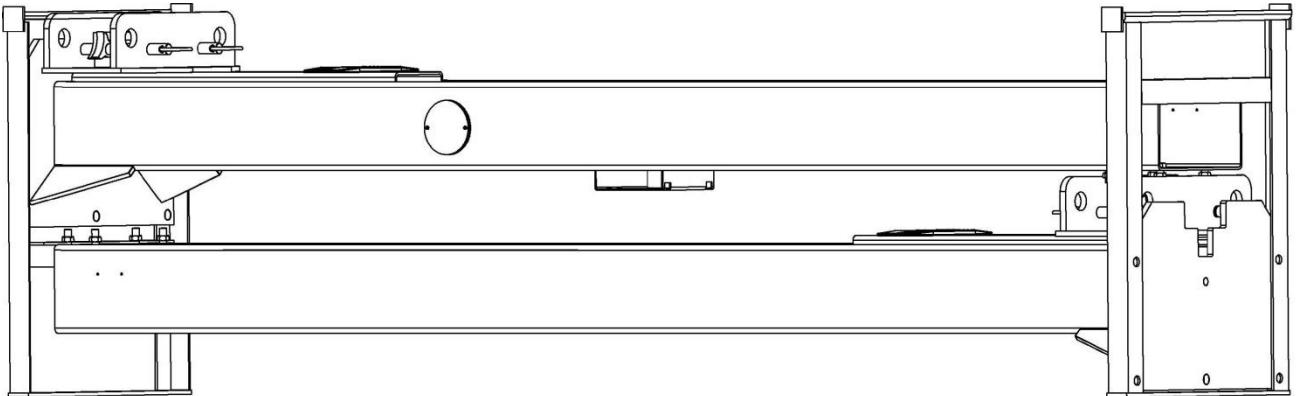

Figure 2: Package with transport protection

- 1) Remove the packaging and remove the box containing the accessories and cover plates. Read and understand the operating instructions before proceeding.
- 2) First you have to put a support between both columns or lift one of the two columns with the help of a crane. Then remove the screws from the frame.

**Attention: Please take special care that the column cannot fall down. The accessories could be damaged or persons injured.**

- 3) After removing the first column place a column under the other column. Then remove the screws from the caddy.
- 4) Set up both columns. Align the main and secondary column with each other (outer edge of base plate to outer edge of base plate approx. 4028mm)
  - a) After unpacking you have to decide on which column you want to fix the power supply and the operating unit.
  - b) Place a column, place the baffle plate on this column and determine by erecting the second column and applying the exact distance to the second side of the baffle.
- 5) First attach the main post, then the secondary post.
  - a) Drill the holes in the foundation with a percussion drill for each ground anchor. Drill perpendicular to the ground plane.
  - b) Carefully remove dirt and dust after drilling (vacuum and blow out if necessary).

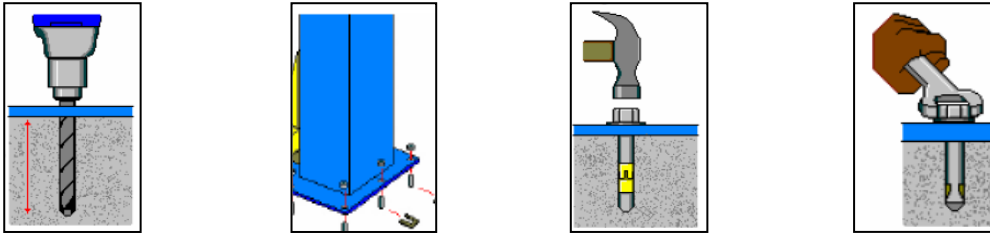

Figure 3: Steps for mounting the post to the ground

6) Install the slot base plate

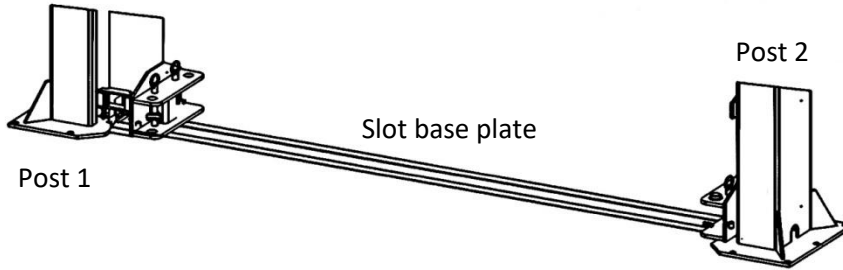

Figure 4: Installation of slot base plate

7) Mount the safety locks, the four electromagnets and the corresponding protectors

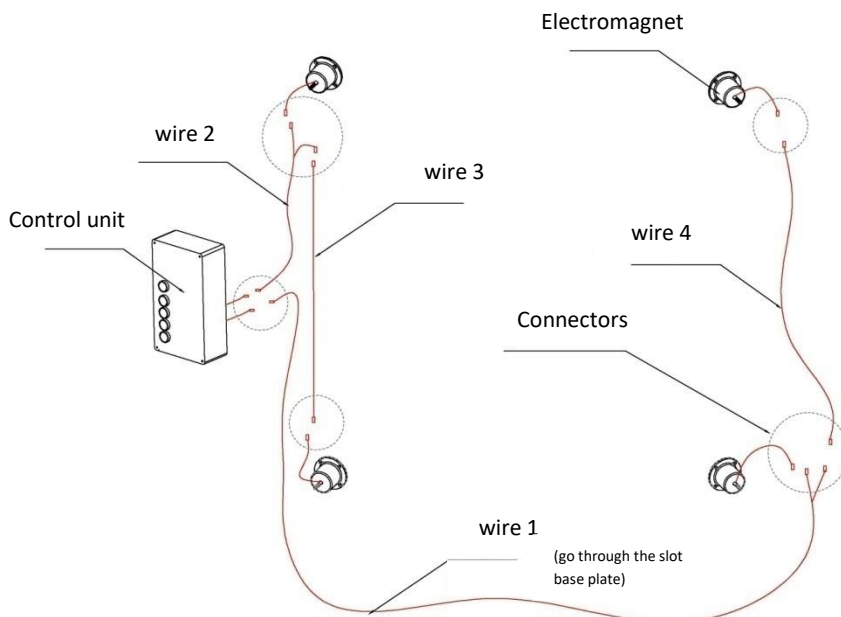
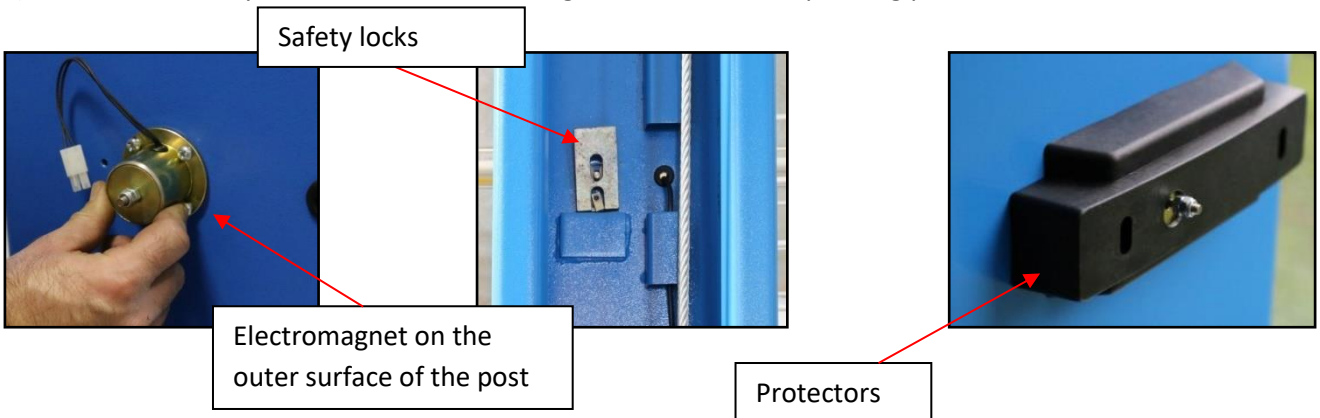

Figure 5: Connection for electromagnets

## 8) Mount the hydraulic system

### a) Mount the power unit

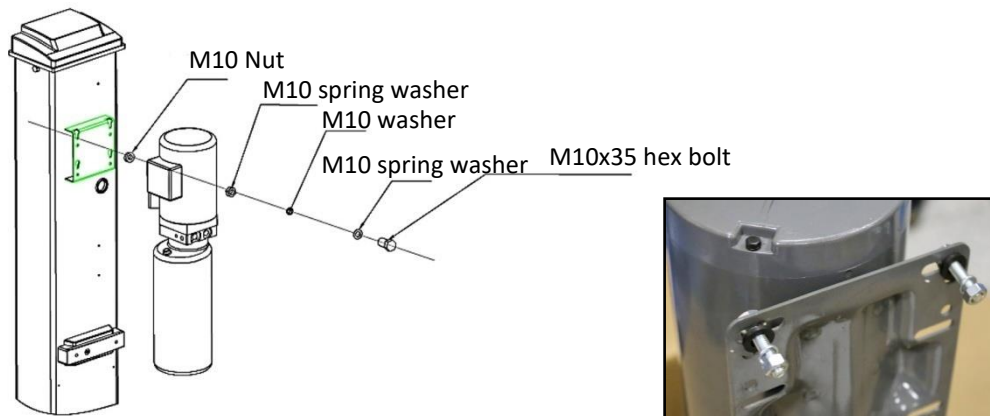

Figure 6: Mount the power unit

### b) Make sure all hose ends are clean and free of dirt

### c) Connect the hydraulic lines as shown in the following figure or in the hydraulic circuit diagram

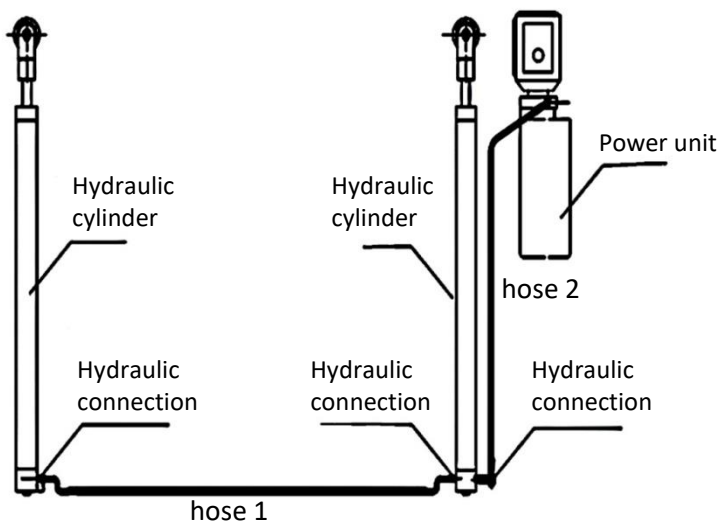

Figure 7: Mount the hydraulic hoses

## 9) After installing the safety locks, connect the carriage to the steel cable

### a) Align the carriages on both sides of the column approximately 800mm above the ground level

### b) Make sure that the safety catches on both sides of the column are locked in place before starting to assemble the steel cables

### c) **The carriages must be at the same height from the ground before proceeding**

### d) Tighten the steel cables as shown in the following figure

### e) The steel cables must be set "taut" on both sides of the column. Make sure that during the later test run (see 14)) the locking sound of the safety locks on both sides is heard synchronously. If this is not the case, the steel cables or a steel cable must be tightened.

### f) The ropes should always be secured against unintentional loosening (countered) and oiled to ensure a long service life

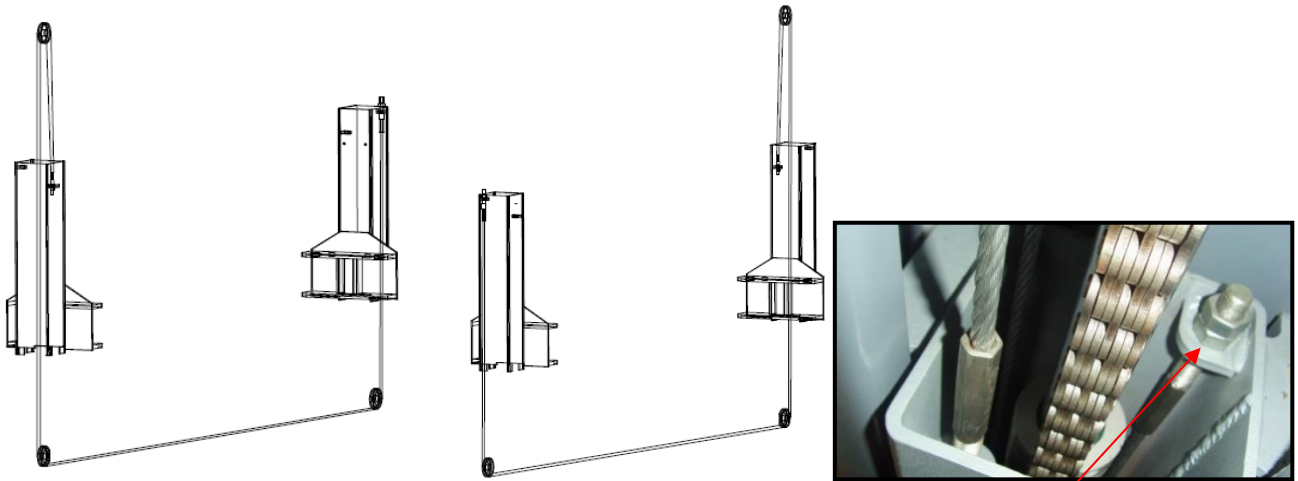

Figure 8: Mount the steel cables

Thread for adjusting the steel cord tension

**Attention:** After adjusting the steel cable tension, the adjusting nuts on both column sides must be countered with another nut!

10) Mount the control unit or the control box

- a) Mount the operating unit on the main post
- b) Connect the power supply to the control unit as shown in the following figure

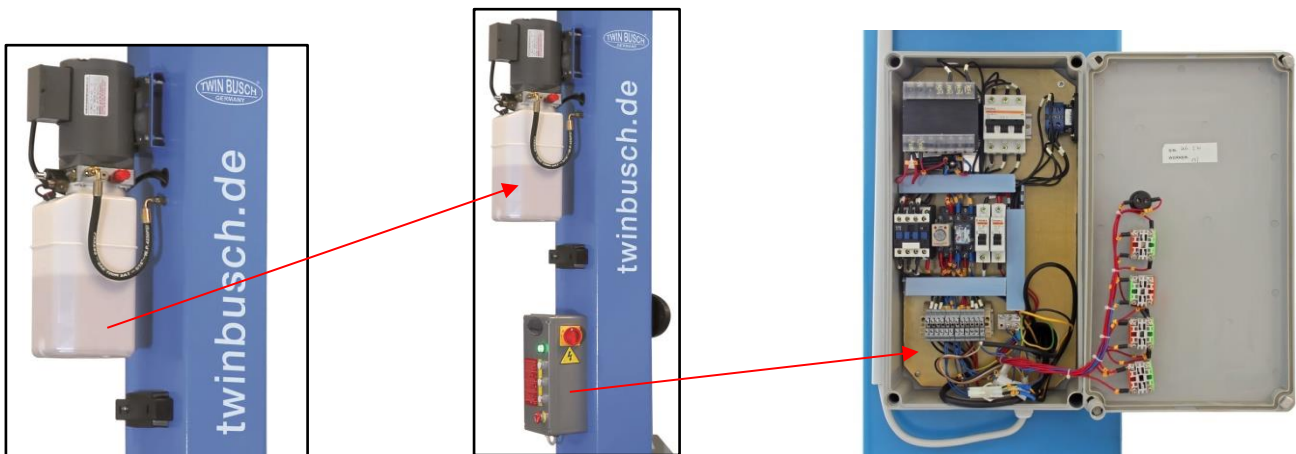

Figure 9: Connection of power supply to control unit

- c) Mount the limit switch at the top of the main pillar, as shown in the following figure

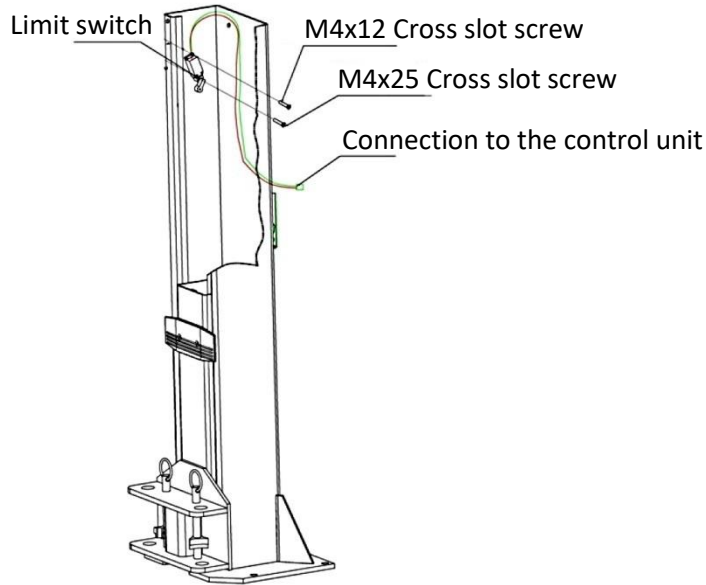

Figure 10: Mount the limit switch

11) Install the protective covers of the hydraulic lines

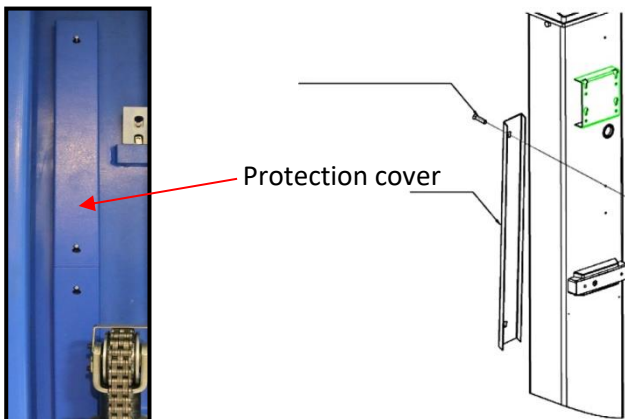

Figure 11: Mount the protection cover

12) Mount the lifting arms

- a) Insert the lifting arms into the carriages, pay attention to the correct gearing of the anti-rotation blocks
- b) Place the lifting arm bolts in the provided holes as shown in the figure below

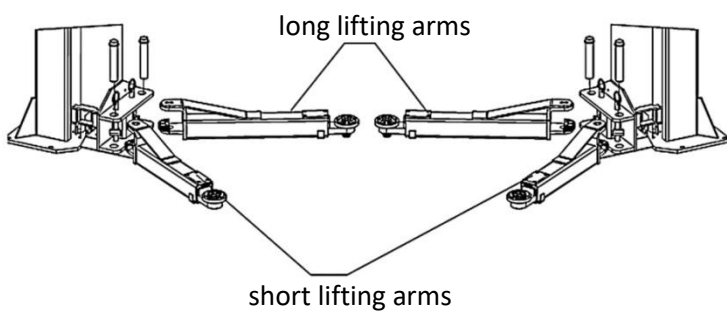

Figure 12: Mount the lifting arms to the carriage

## 13) Fill the system with hydraulic oil

The hydraulic oil tank holds a filling volume of approx. 10 liters. To make sure that the lift works correctly you should fill the oil tank 80% with hydraulic oil. **Hydraulic oil type: HLP 32**

## 14) Test run

- Follow the procedure in **9 Commissioning** and make sure that **NO** vehicle is allowed on the lift during a test run.
- Before the test run, check all connections and connections for their correct functioning

## 15) Montieren Sie den Ketten- und Türanschlagschutz

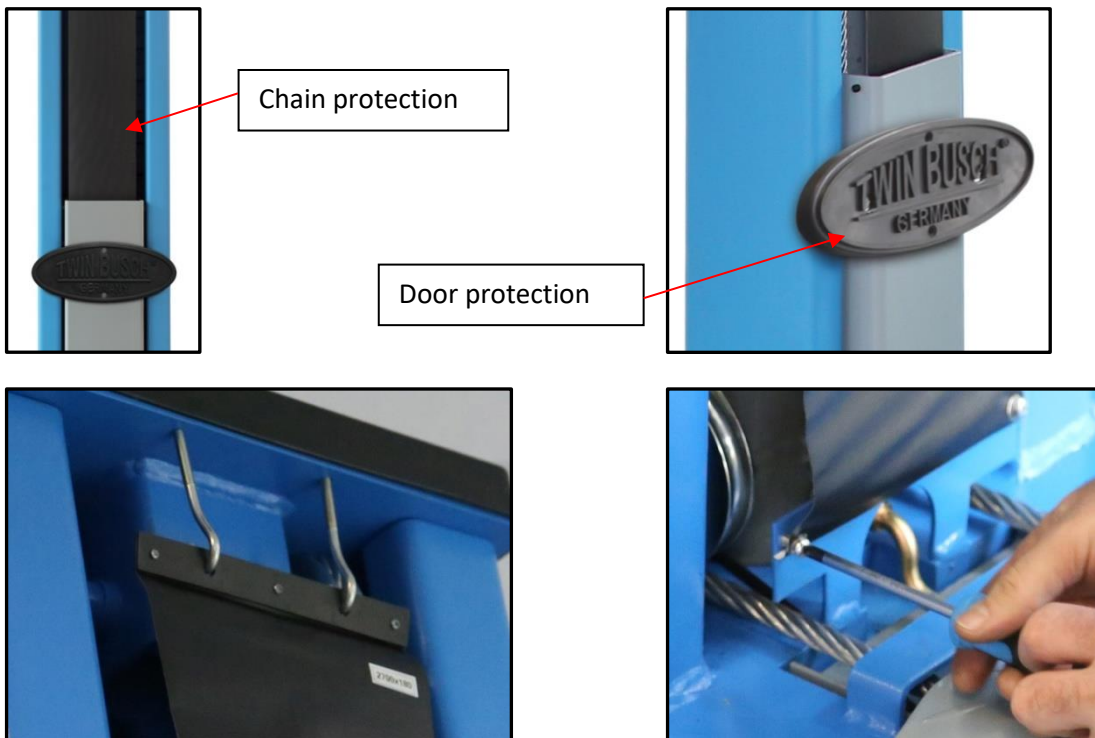

Figure 13: Mount the chain and door protection

## 16) Mount the base plate

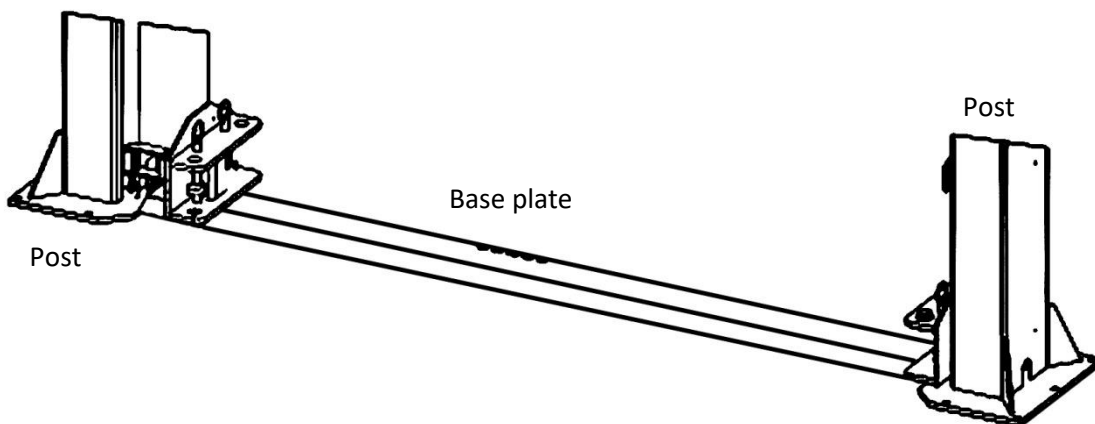

Figure 14: Mount the base plate

## 8.4. Checkpoints after installation

S/N	To verify	yes	no
1	Are the posts vertical to the floor? (90°)		
2	Are the posts parallel to each other?		
3	Is the oil hose connected correctly?		
4	Is the steel cable correctly and firmly connected?		
5	Are all lifting arms correct and securely mounted?		
6	Are the electrical connections correct?		
7	Are all the joints screwed tight?		
8	Are all parts that need to be greased greased?		

Chart 3: Checkpoints after installation



## 9. Commissioning

### 9.1. Safety precautions

- a) If the safety devices are defective or have abnormalities, the lifting platform must under no circumstances be put into operation!
- b) Check all connections of the hydraulic lines for a tight fit and their functionality. If there are no leaks, then a lifting process can be started.
- c) Only the operator should be near the lift during a lifting or lowering operation. Always ensure that no persons are in the danger zone.
- d) Vehicles should always be aligned so that the center of gravity of the vehicle is centered between the lift columns. If this is not the case, the lift should not be used. Otherwise, neither we nor the intermediary, if any, will assume responsibility for any problems or damages caused thereby.
- e) When the desired lifting height has been reached and the safety latches have engaged, disconnect the power supply to the lift before starting work in order to prevent accidents due to unintentional operation by other persons.
- f) Make sure the safety latches are engaged before starting to work on or under a vehicle. There must be no persons during the lifting and lowering process in the work area of the lift.

### 9.2. Description of the control unit (control box)

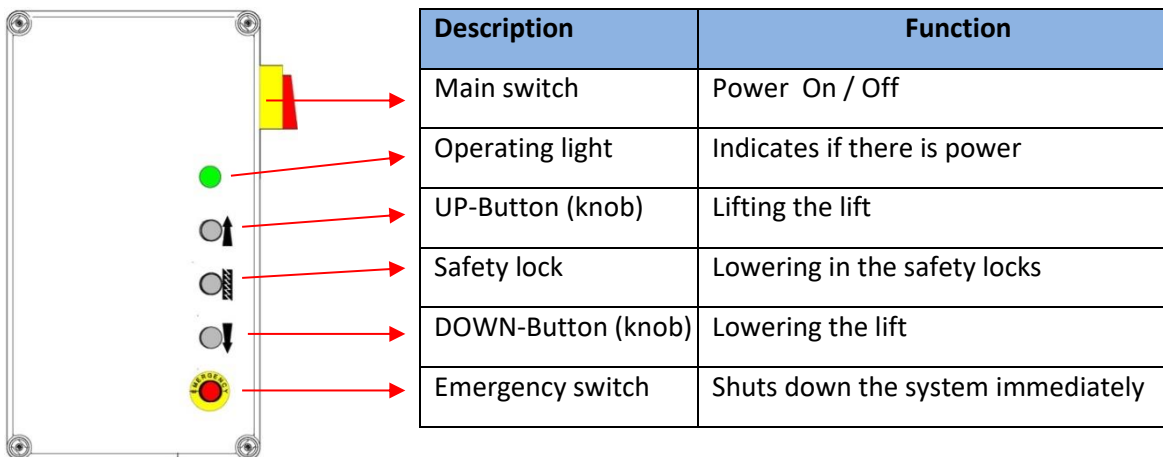
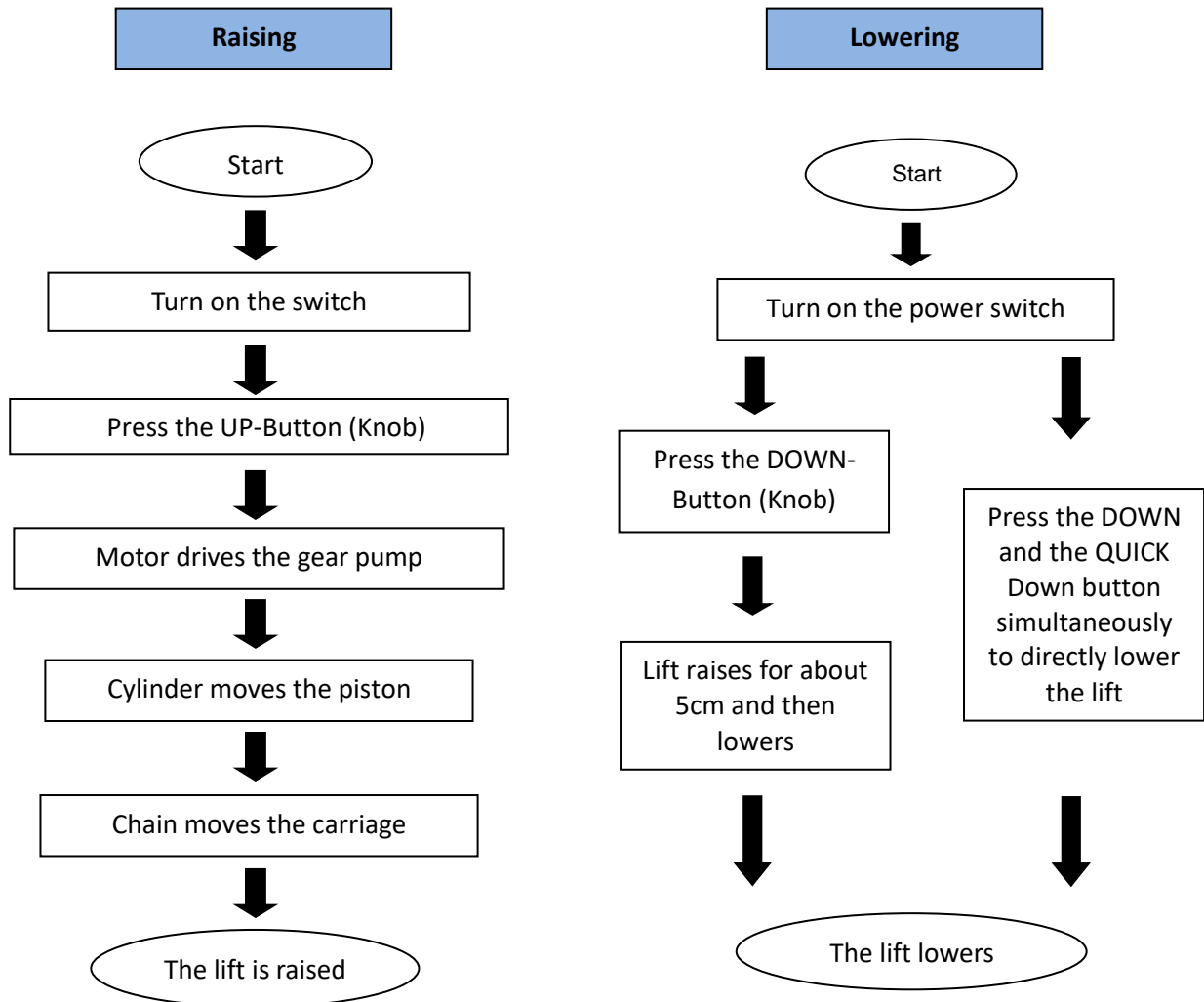

Figure 15: Description of the control unit

9.3. Flow chart for operation



## 9.4. Operation manual

### 9.4.1. Raise the lift

1. **Read and understand the operating instructions before starting to work.**
2. Connect the power supply and turn the main switch ON
3. Center the vehicle with the center of gravity between the two posts
4. Align the lift arms so that the pickup points align with the lifting points. Make sure that the vehicle is correctly positioned.
5. Press the UP button on the control unit until the pickups touch the vehicle at the pickup points specified by the vehicle manufacturer and lift the vehicle for about 10-15 cm. Stop the lifting process and make sure that the vehicle has been picked up correctly and safely.
6. After final alignment and control, press and hold the UP button again until the desired lift height is reached.
7. Press the lock-button to lock the carriages in the safety locks.
8. Turn the main switch OFF and start working at or under the vehicle.

### 9.4.2. Lowering the lift

1. Connect the power supply and turn the main switch ON
2. Press the DOWN button at the control unit. First lift the carriages about 5 cm, in order to release the locking of the safety locks. Subsequently, the electromagnetic release valve opens and the carriages lower.
3. As soon as the carriages have reached the lowest position, the support arms can be swiveled out under the vehicle.
4. Now the vehicle can be removed.

## 9.5. Emergency lowering function in case of power failure

### 1. With NOT engaged lifting carriage

- a) Pull all electromagnets to the outside of the columns at the same time to open the safety locks.

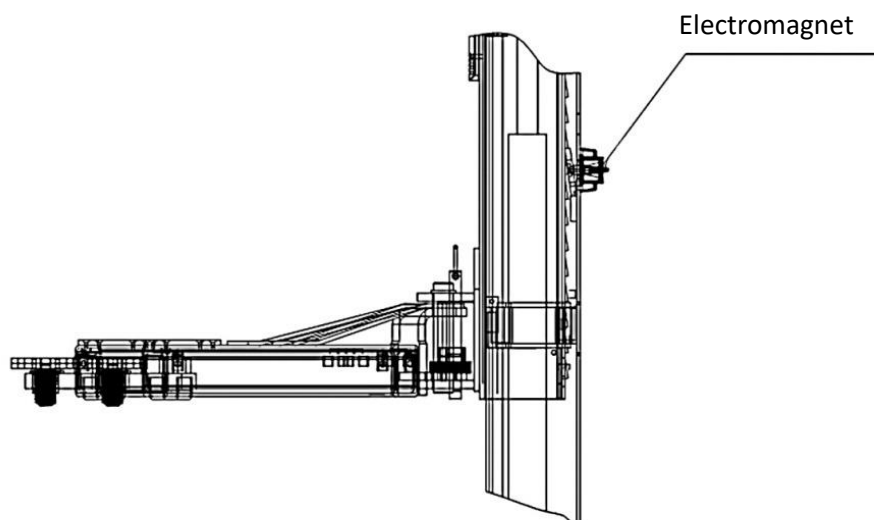

Figure 16: Unlocking all electromagnets

- b) Operate the manual drain (bayonet lock).  
(Push in the knurled screw and turn it -> counterclockwise: "Open", -> clockwise: "Close")

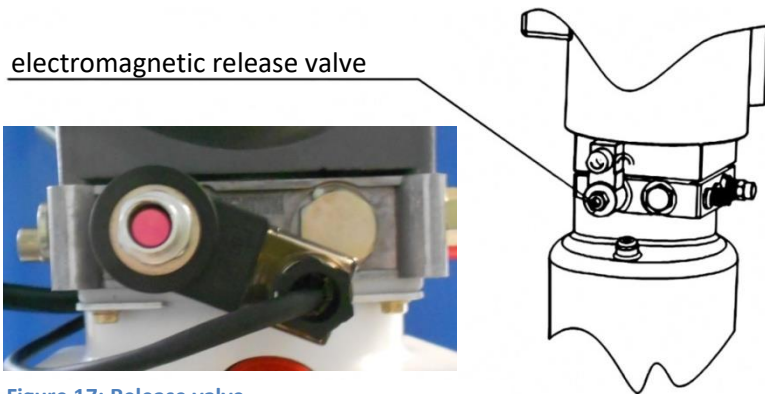

Figure 17: Release valve

2. With engaged lifting carriage

- a) Unscrew the plug to be able to connect the manual hydraulic pump

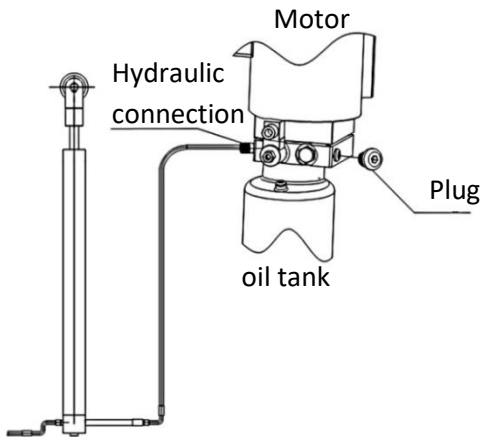

Figure 18: Plug

- b) Use a hand-operated hydraulic pump to pump oil into the cylinder to release the lock

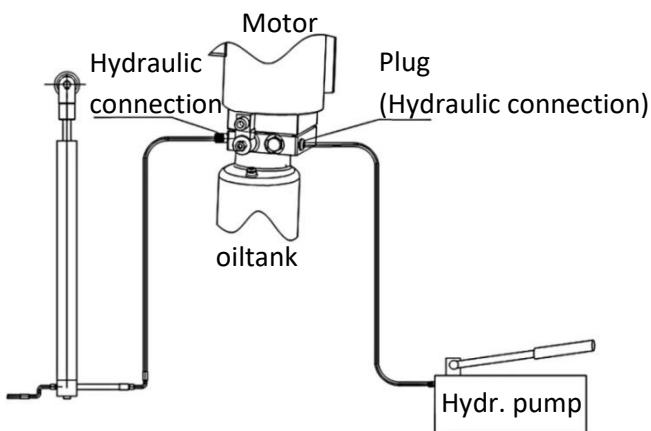

Figure 19: Connect a hand operated hydraulic pump

- c) Then follow the procedure from 1. With **NOT** engaged lifting carriage

## 10. Troubleshooting

**Attention:** Do not hesitate to contact the specialist staff of Twin Busch GmbH if you cannot rectify an error yourself. We will be happy to help you solve your problem. In this case, document the error and send us pictures and a precise description of the error so that we can identify and rectify the cause as quickly as possible.

The following chart lists possible errors, their cause and the associated troubleshooting for faster identification and self-correction.

PROBLEM	CAUSE	SOLUTION
Unusual noise	Wear on the inner side of the columns	Grease the sliding surface of the columns
	Pollution on the inner side of the columns	Remove the dirt
The engine cannot be started and the lift does not raise	The wire connections are loose	Check the wires and reconnect them
	The engine is damaged	Replace the engine
	Limit switch is damaged or the wire connection is loose	Reconnect the wires or replace the limit switch
Engine is running, but the lift doesn't raise	Motor runs in the wrong direction of rotation	Check the wire connection
	Pressure relief valve is loose or dirty	Clean and screw it tight
	Gear pump is defective	Replace the pump
	Oil level is too low	Add oil
	Oil hose has loosened or torn off	Attach or replace it
	Damping valve is loose or jammed / clogged	Clean and screw it tight
Carriage slowly come down after lifting	Oil hose is leaking	Check or replace it
	Oil cylinder / piston is leaking	Replace the seal
	Directional valve is leaking	Clean or replace it
	Pressure relief valve is leaking	Clean or replace it
	Manual or electrical drain valve is leaking / dirty	Clean or replace it
Lifting too slow	Oil filter is dirty or jammed	Clean or replace it
	Oil level is too slow	Add oil
	Pressure relief valve is incorrect installed	Assemble it properly
	Hydraulic oil is too hot (over 45°C)	Let it cool down or change the oil
	Cylinder seal is worn out	Replace the seal
Lowering too slow	Throttle valve is jammed / dirty	Clean or replace it
	Hydraulic oil is dirty	Change the oil
	Drain valve is clogged	Clean it
	Oil hose is damaged / kinked	Replace it
Steel cable is worn out	Not greased during installation or worn out	Replace it

chart 4: Troubleshooting

## 11. Maintenance

Regular maintenance of your lift ensures you a long and safe use of the lift. How often you service your lift depends on the ambient conditions, the degree of contamination and, of course, the stress and strain on the lift.

The following points must be checked and lubricated regularly:

No.	Description
1	Upper pulley
2	Steel cable
3	Sprocket
4	Chain
5	Carriage
6	Bolt
7	Safety block
8	Beam
9	Pick up points
10	Lower pulley

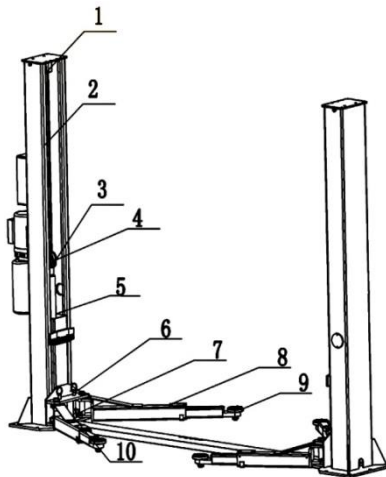

figure 20: Description of lubrication points

### 11.1. Daily inspection and maintenance of the lift elements before use

A daily check of the safety-relevant components must be carried out before each start-up! This can save you a lot of time due to a breakdown, major damage or even injuries.

- Check all connections and screw connections for tight fit
- Check the hydraulic system for leaks and functionality
- Check the support arm locks for correct function
- Check whether the safety locks and working properly in a test run (without vehicle)
- Clean heavily soiled lift elements
- Lubricate all lift elements that are not well lubricated

### 11.2. Weekly inspection and maintenance of the lift

- Check the mobility of all adjustable and flexible lift elements
- Check the condition and correct functioning of all safety-relevant lift elements
- Check the level of hydraulic oil. (lowered lifting carriage – filling level high; max. lifting carriage high – filling level low)

### 11.3. Monthly inspection and maintenance of the lift

- Check all screw connections for tight fit
- Check the lifting carriage, the support arm bolts, the support arms and all other movable lift elements for wear and lubricate them
- Check the condition of the steel cable for signs of wear and oil the steel cable with low-viscosity lubricating oil

### 11.4. Annual inspection and maintenance of the lift elements

- Empty and clean the hydraulic oil tank and replace the hydraulic oil
- Replace the oil filter

**If you follow the maintenance intervals and maintenance activities mentioned above, your lift will remain in good condition and damage and accidents will continue to be avoided.**

## 12. Behavior in the event of a malfunction

If the lift malfunctions, simple errors may be the cause. Use the following list for troubleshooting \*). If the cause of the error is not listed or cannot be found, please contact the competent Twin Busch GmbH Team.

**Never attempt your own repairs, especially not on safety devices or electrical system parts.**

\*) Points depending on the design and type of the lift





**Working on electrical systems only by an electrician!**

### **Problem: The lift can neither be raised nor lowered**

#### **Possible causes**

No power supply available  
Power supply interrupted  
Main switch not turned on or defective  
Emergency stop pressed or defective  
Fuse in the power connection has tripped or is defective  
Fuse in control box has tripped or is defective

#### **solution**



check power supply  
check power supply  
check main switch   
unlock emergency stop or check   
check fuse  
check fuse

### **Problem: The lift cannot be raised**

#### **Possible causes**

With three-phase current: one phase missing  
With three-phase current: direction of rotation wrong  
  
Oil pump defective  
Emergency release open  
Motor is defective  
overload

#### **solution**

check power supply   
check direction of rotation, change phase if necessary   
Notify Twin Busch Service  
close emergency drain valve  
Notify Twin Busch Service  
overload valve has opened, reduce load

### **Problem: The lift cannot be lowered**

#### **Possible causes**

Lift rests in safety locks  
  
The lift has moved into the limit switch  
  
Motor is defective  
  
Lift has been blocked when lowering

#### **solution**

raise the lift a little, pull the locks and lower the lift  
If necessary, release limit switch, raise 1cm and lower the lift  
open the safety lock and lower the lift using the emergency lowering  
Raise the lift slightly again and remove the obstacle



13. Appendix

13.1. Dimensions of the lift

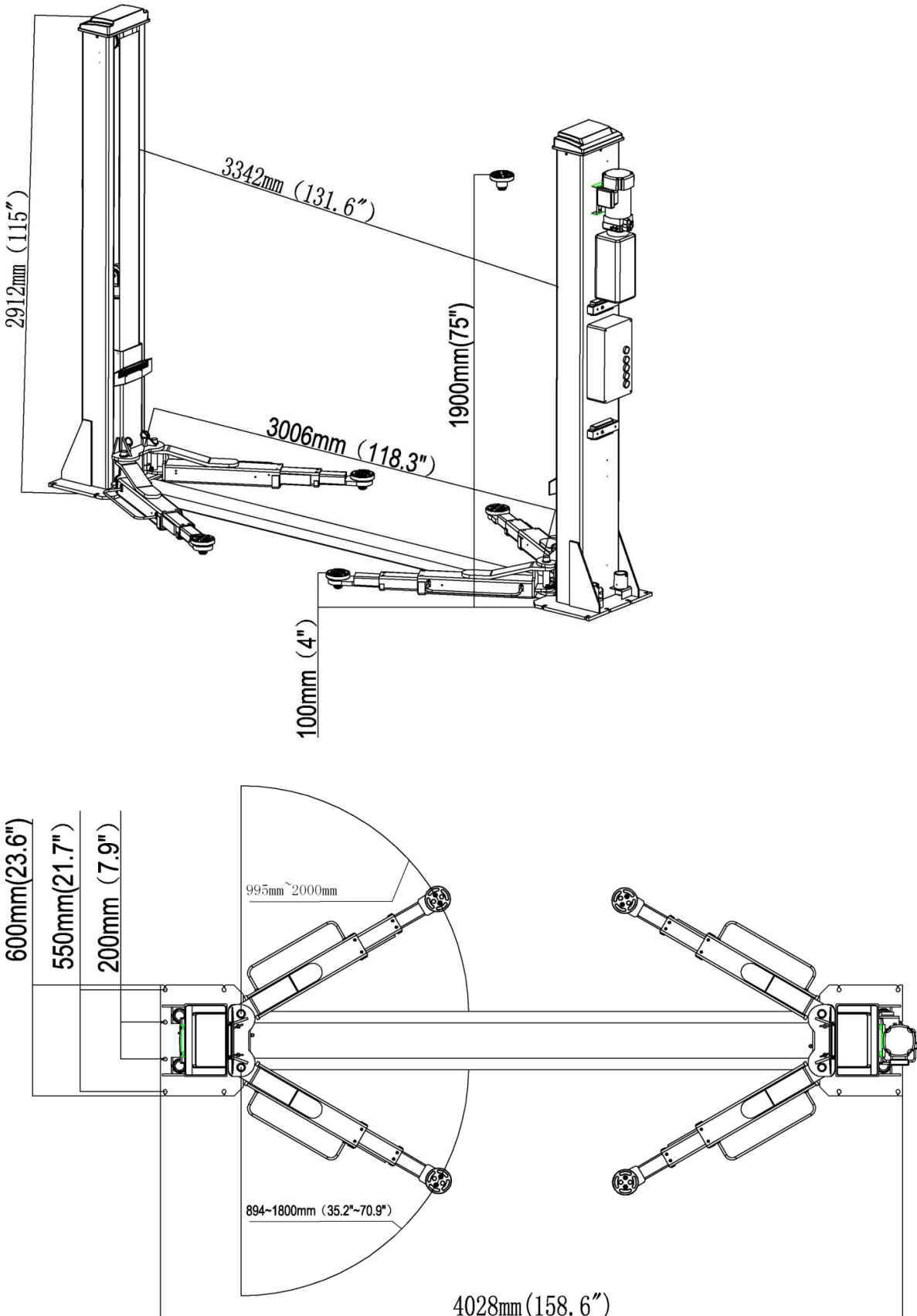

## 13.2. Foundation requirements and working area

### Concrete requirements:

- Concrete C20/25 according to DIN 1045-2 (previous name: DIN 1045 concrete B25)
- The floor must be horizontal and have a flatness of less than 5mm/m
- Newly poured concrete must cure for at least 28 days

### Foundation dimensions:

- Ideally, the entire hall floor should be made of concrete C20/25 with a thickness of min. 250mm

Minimum dimensions of the foundation plate (lifting platform placed in the middle)

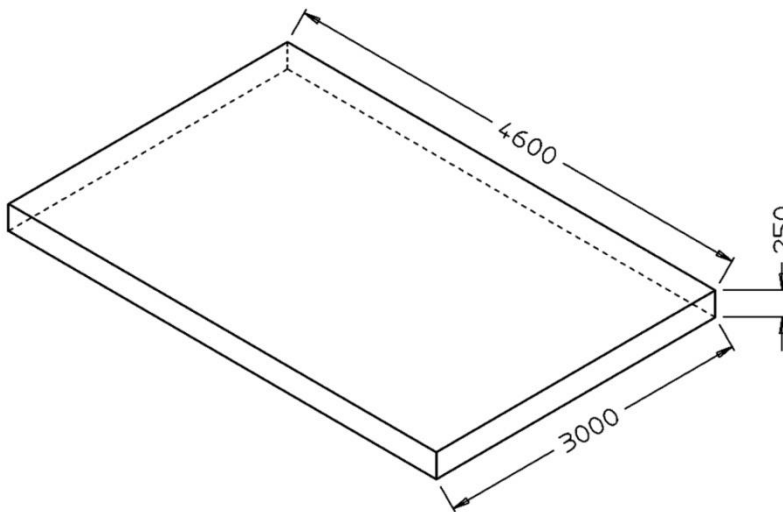

### Alternatively in H-shape or two blocks:

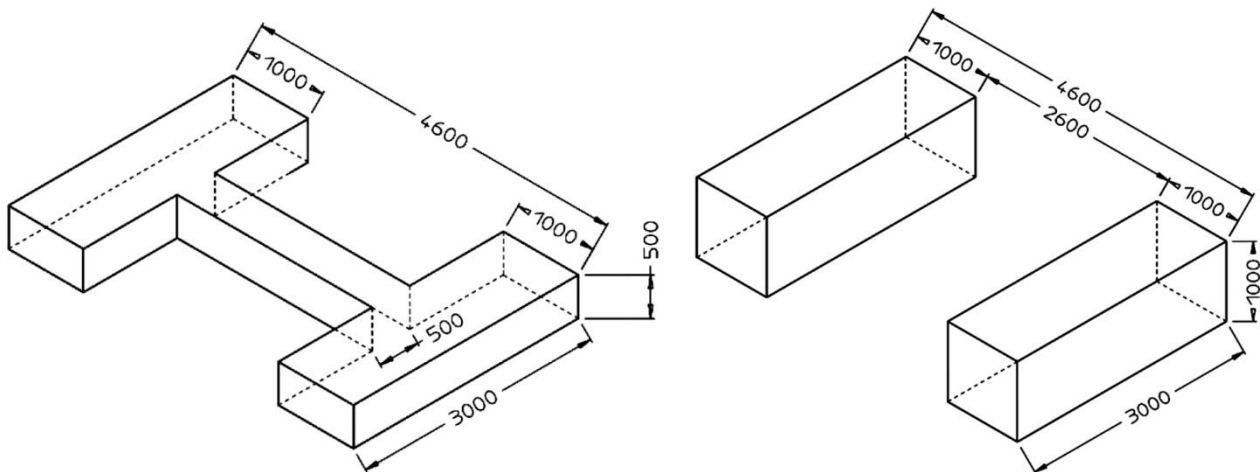

### Other requirements:

- The surrounding ground must be suitable for the load, e.g. no sandy soils, etc.
- Reinforcements in concrete are not mandatory for the proper use of the lift, but are recommended
- In case of doubt, the foundation should be determined and checked by a structural engineer

**The following must be observed for floors exposed to frost:**

When exposed to frost, the concrete must comply with exposure class XF4, as dripping de-icing cannot be excluded.

This results in the following minimum requirements for the concrete when exposed to frost:

Exposure class:	XF4
Maximum w/z:	0,45
Min. compressive strength:	C30/37 (statt C20/25)
Min. cement content:	340 kg/m <sup>3</sup>
Min. air pore content:	4,0 %

However, it must be noted that the lifts are not designed for outdoor use. The control box corresponds to IP54, but the rest of the electrical system, motors and limit switches are designed to a maximum of IP44.

**Ankerbolzen Befestigung:**

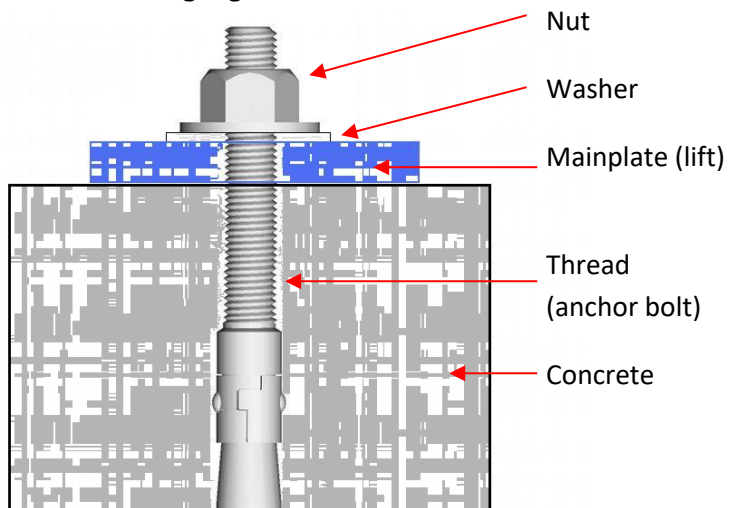

**Tightening torque of the anchor bolts is: 120Nm**

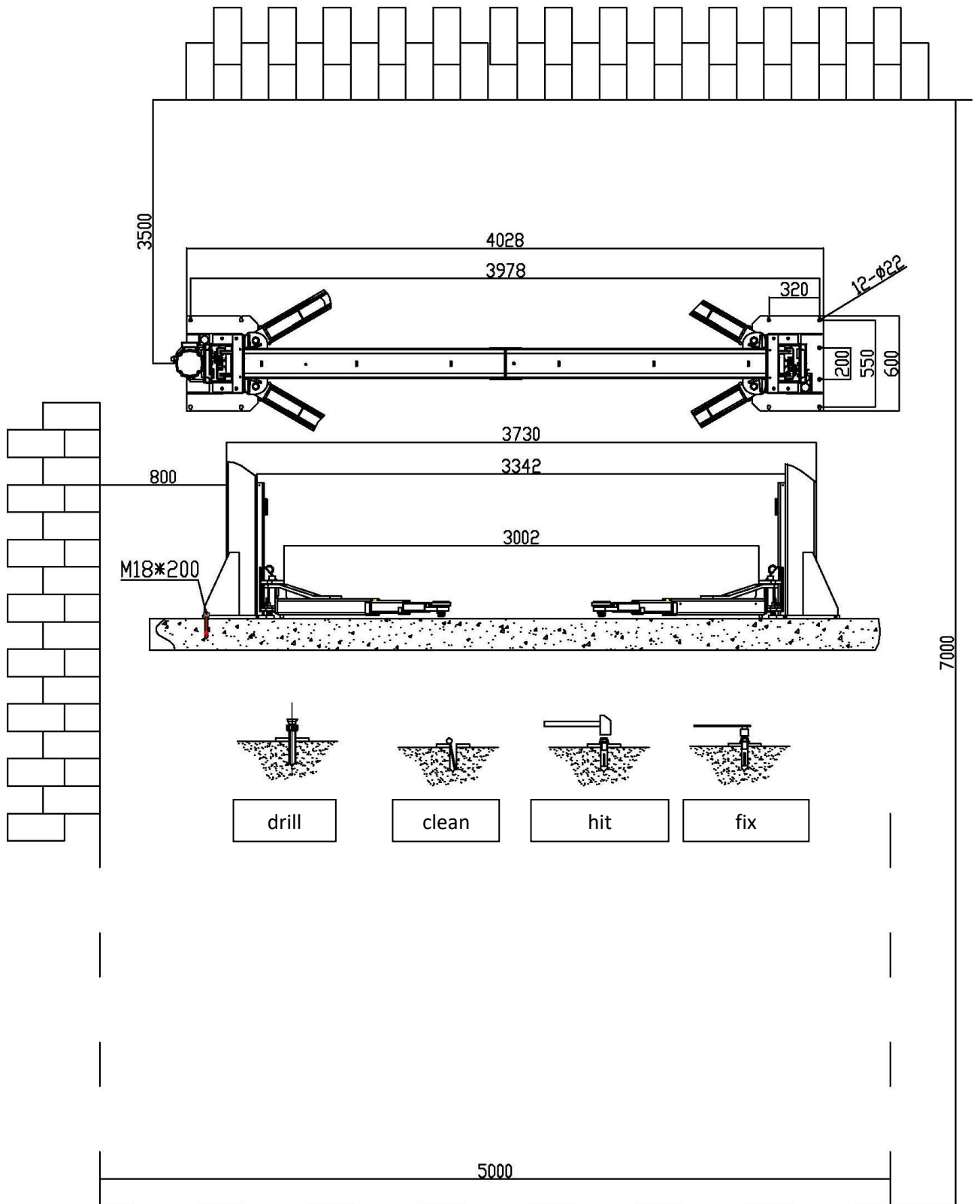

## 13.3. Hydraulic system

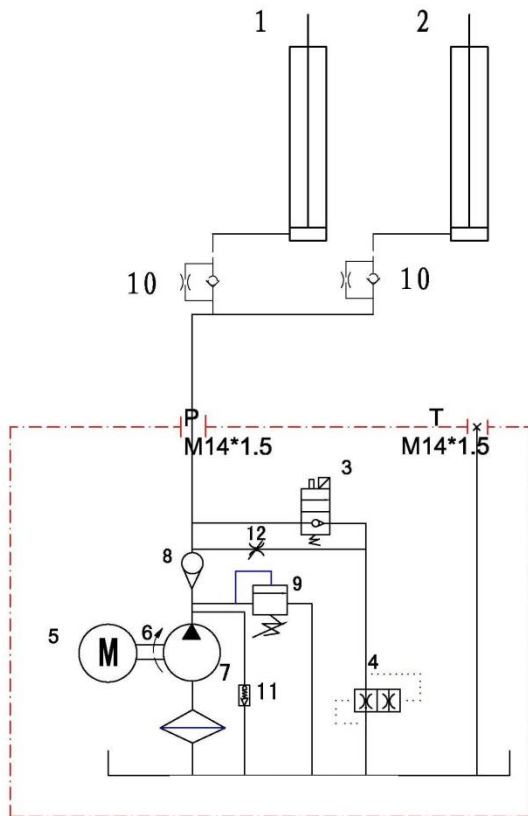

1. Main cylinder
2. Sekundary cylinder
3. Electromagnetic release valve
4. Throttle valve
5. Motor
6. Clutch
7. Gear pump
8. Safety valve (one-direction valve)
9. Pressure relief valve (max.: 19.4Mpa)
10. Choke valve
11. Pressure control valve
12. Relief valve

10 liter oil tank

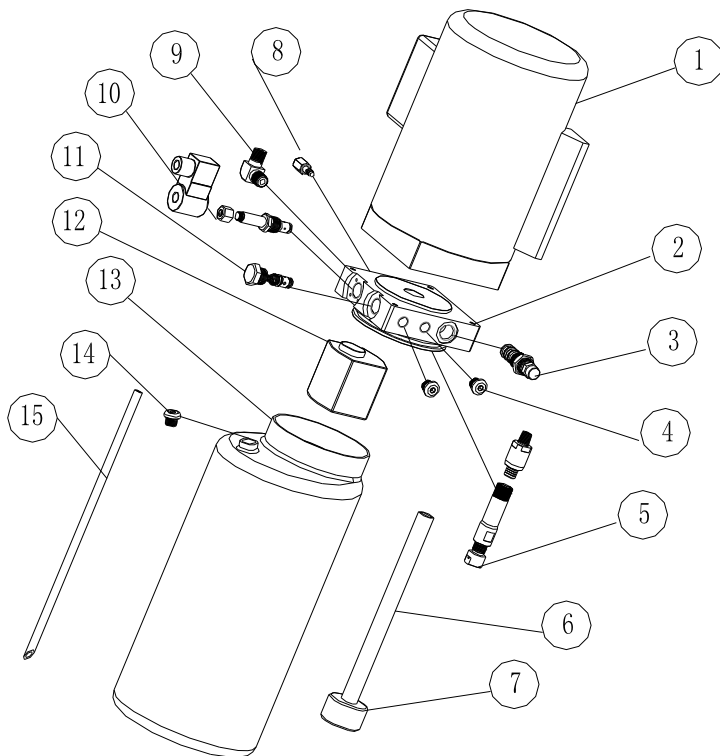

S/N	Name	quantity
1	Motor	1
2	Hydraulic block	1
3	Pressure relief valve	1
4	Screw plug	2
5	Pressure control valve	1
6	Oil suction pipe	1
7	Oil filter	1
8	Throttle valve	1
9	Port connection	1
10	Electromagn. drain valve	1
11	one-direction valve	1
12	Gear pump	1
13	Plastic oil tank	1
14	Oil tank plug	1
15	Oil return pipe	1

## 13.4. Schematics

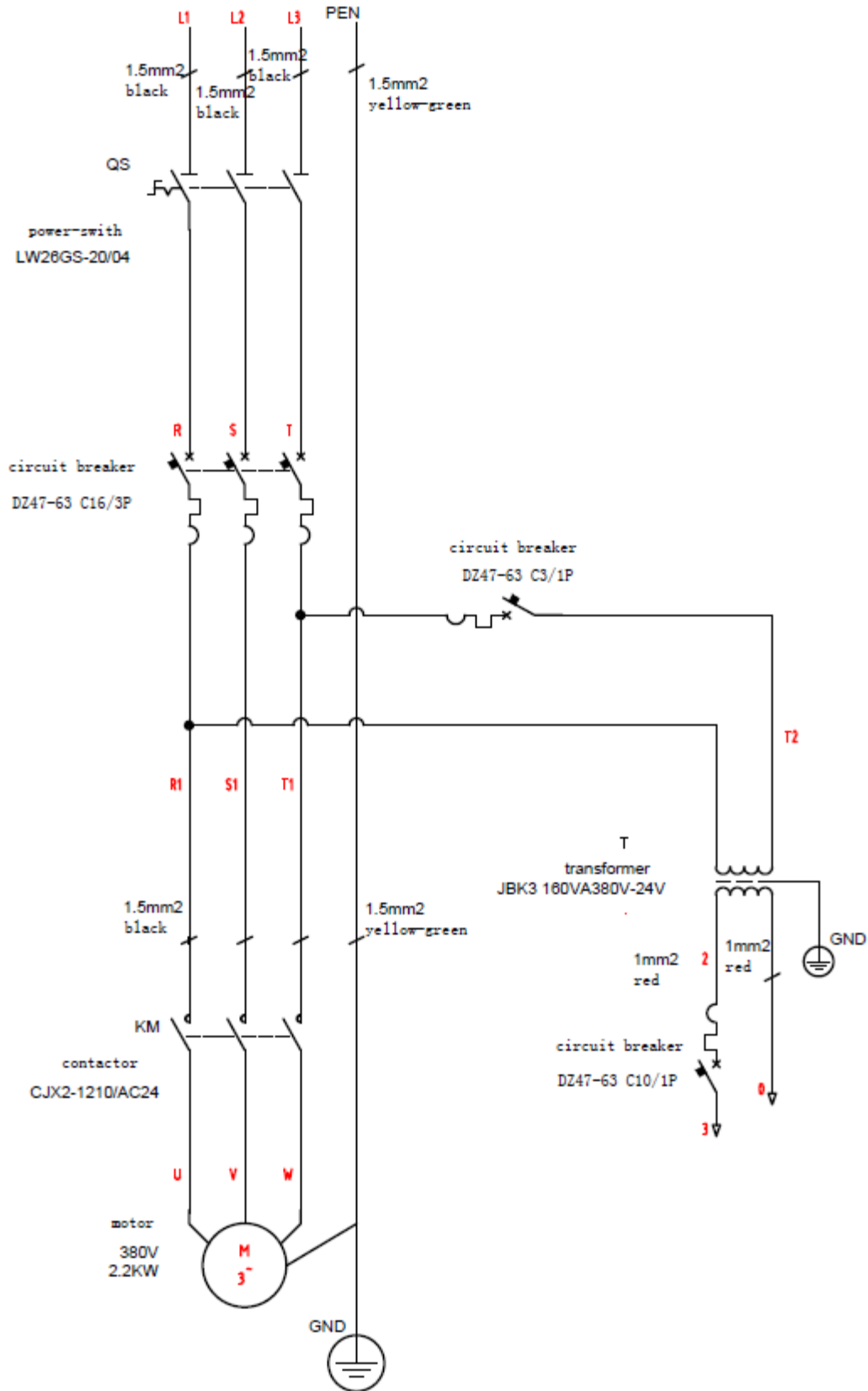

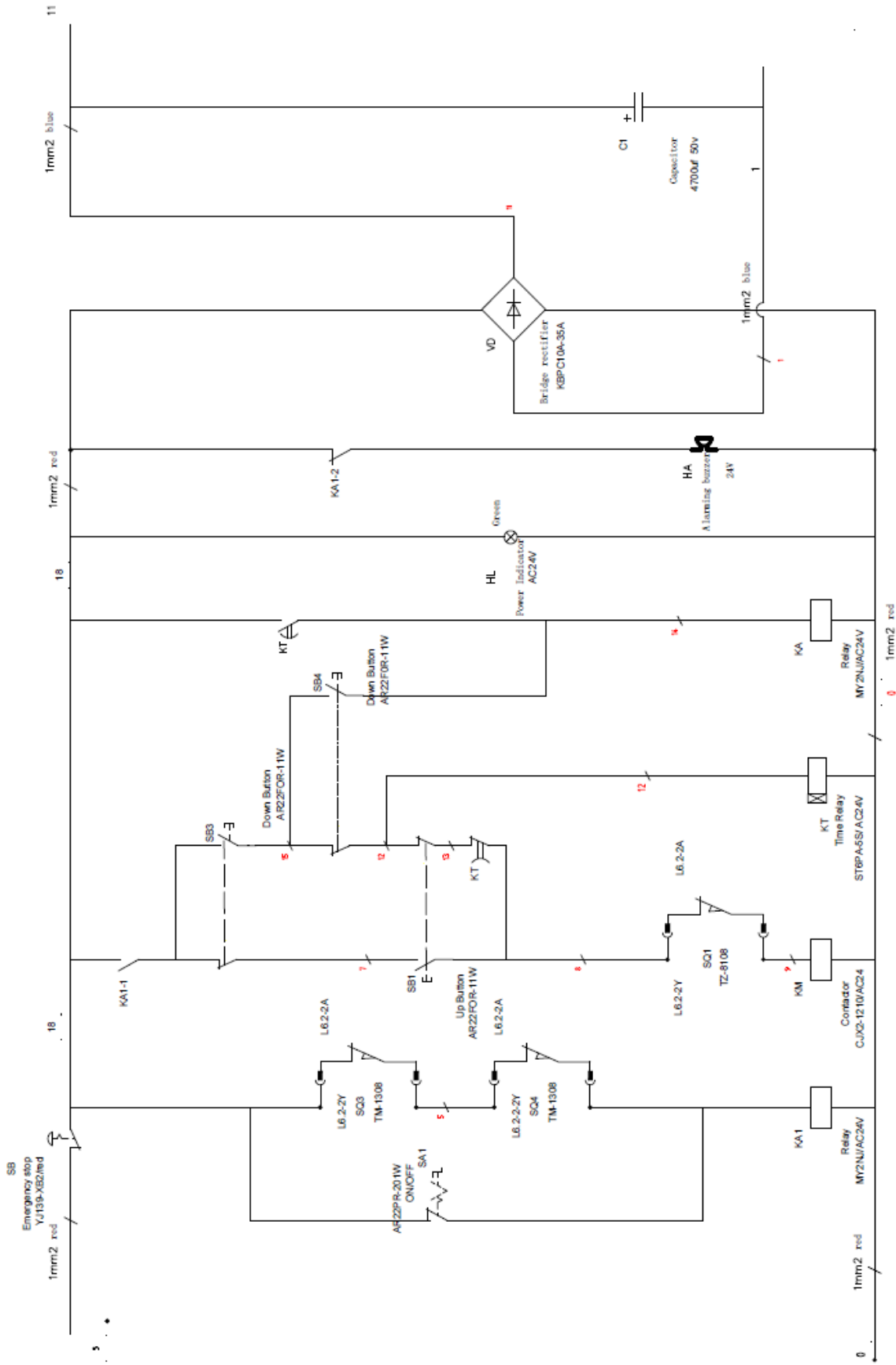



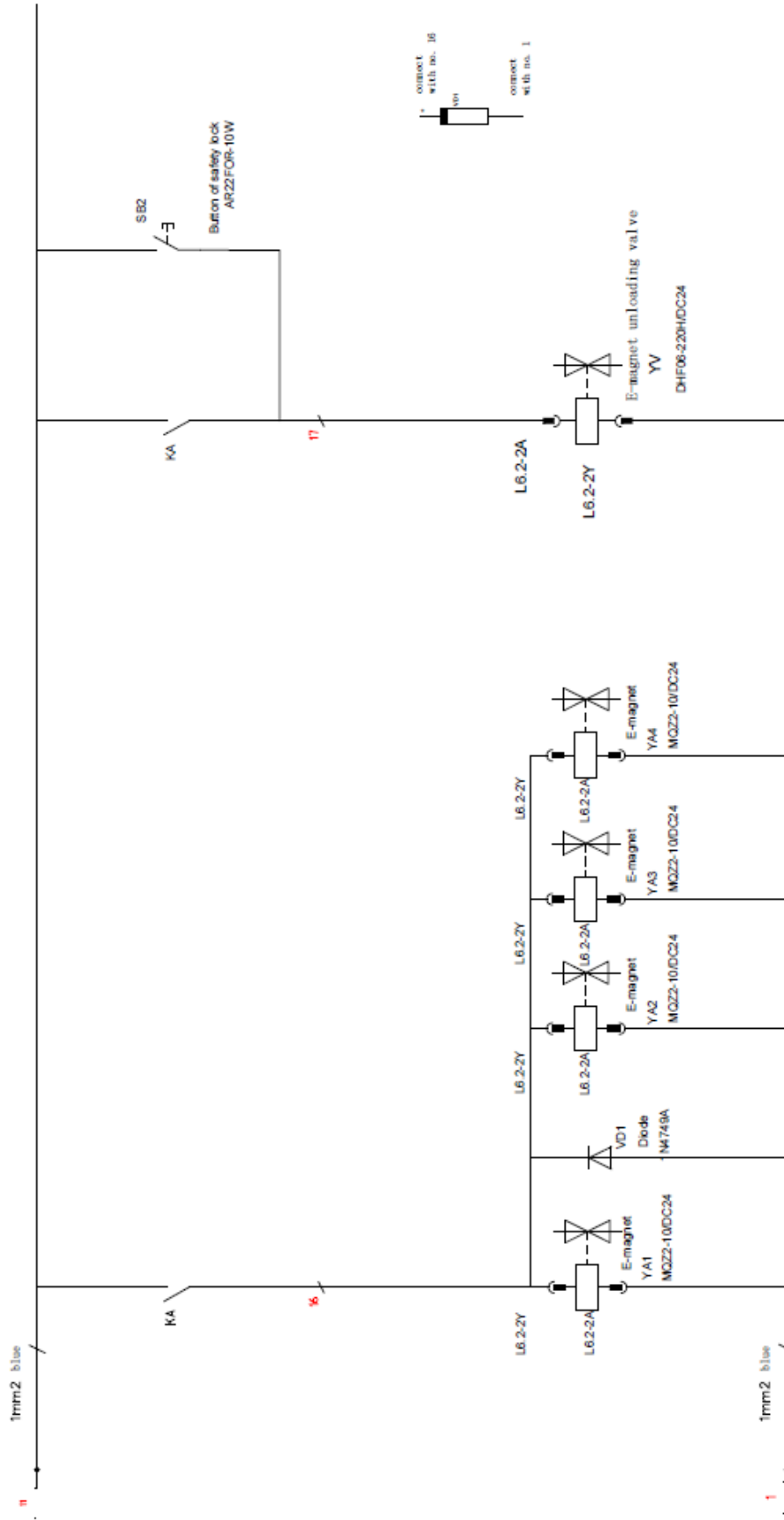

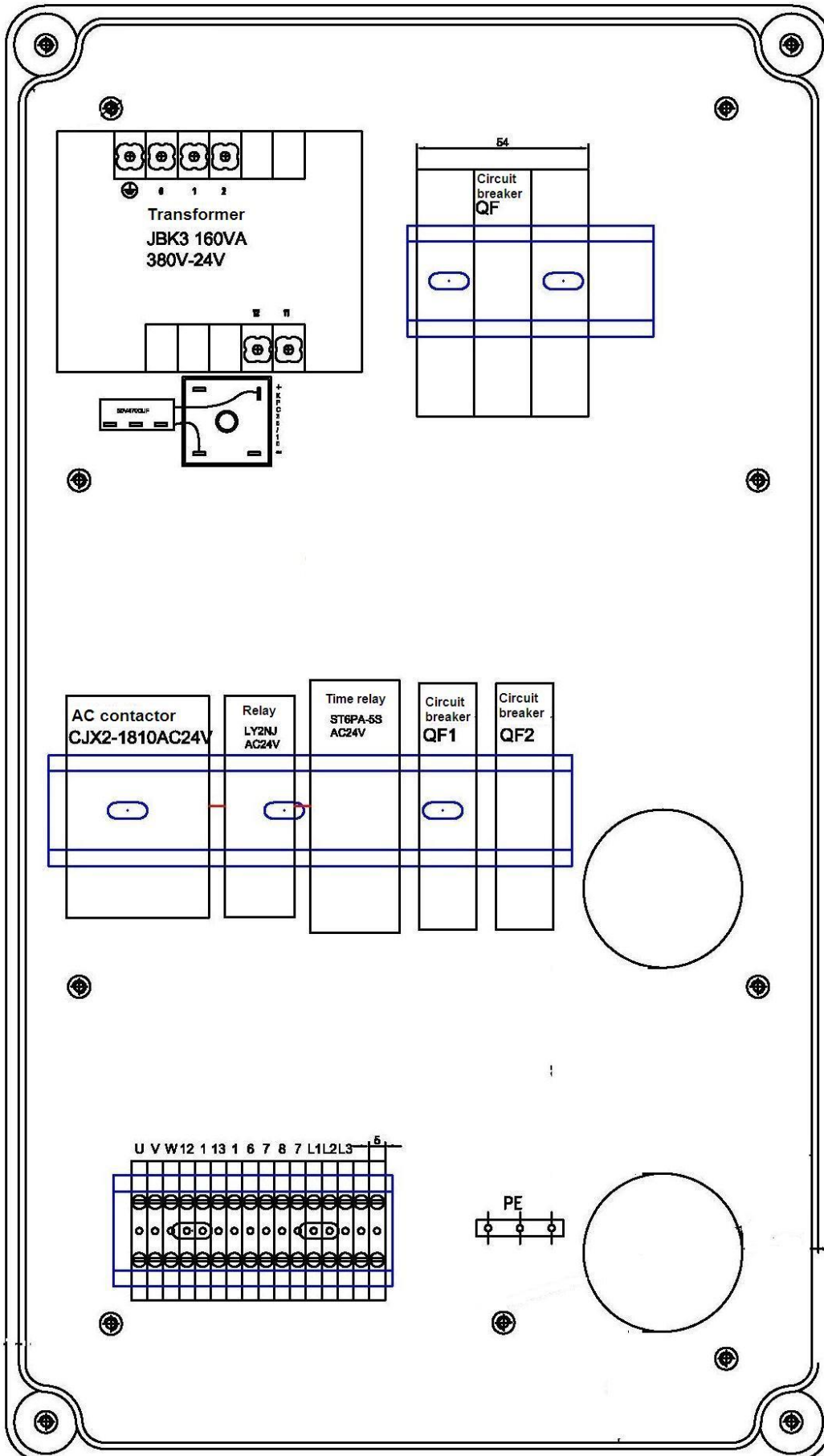

## 13.5. Detailed drawing and parts description of the lift

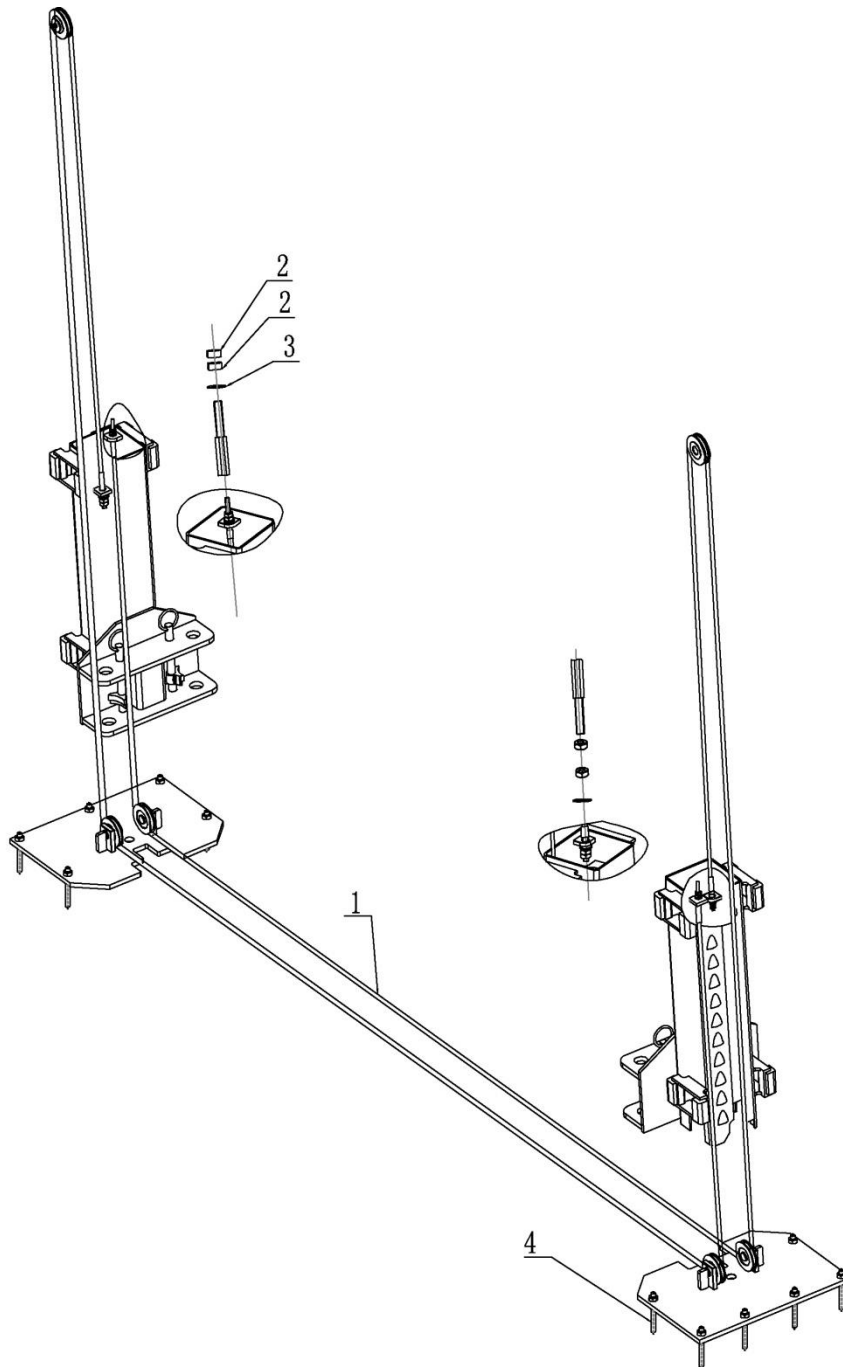

S/N	Name	Drawing-no.	Quantity	Property
1	Steel cabel L=9380mm	8226E-A8	2	assembly
2	M20 hex nut	GB/T6170-2000	4	standard
3	M20 washer (flat)	GB/T95-1985	8	standard
4	M18*200 Anchor bolt		12	standard

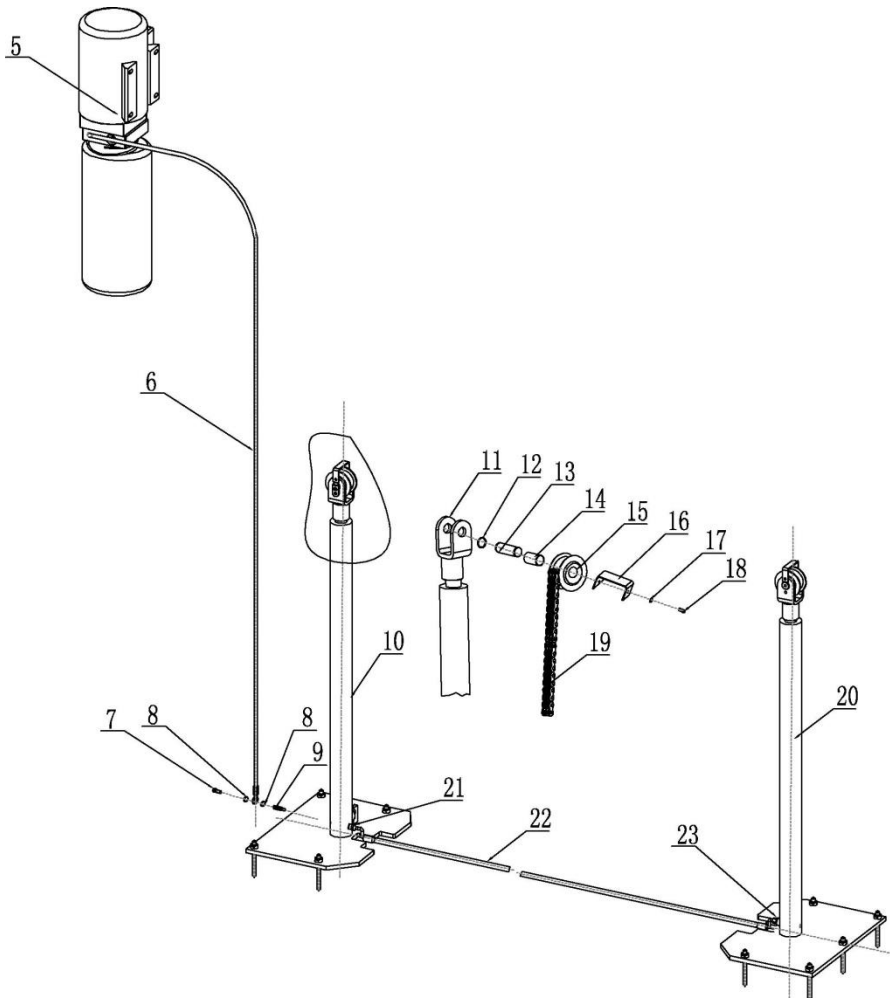

S/N	Name	Drawing-no.	Quantity	Property
5	Motor/Hydraulic unit		1	assembly
6	Oil hose L=2265		1	assembly
7	connector L=70		2	assembly
8	Copper washer		4	standard
9	Connector		2	assembly
10	Hydraulic cylinder	8225E-A4-B2	1	assembly
11	Chain wheel bracket	8226E-A4-B2	2	welded
12	Type B circlip 25	GB/T894.2-1986	4	standard
13	Shaft	8226E-A4-B4	2	Zinc-plating
14	Bearing 2548	SF-1	2	standard
15	Chain wheel	8226E-A4-B3	2	Zinc-plating
16	Baffle plate	8226E-A4-B5	2	Zinc-plating
17	Spring washer	GB/T93-1987	4	standard
18	Inside hex cap screw	GB/T70.1-2000	4	standard
19	8226E chain	LH1266	2	standard
20	Hydraulic cylinder	8225E-A4-B3	1	assembly
21	Connector	NPT3/8-G1/4	1	Q235A
22	Oil hose L=3380		1	assembly
23	Short connector	NPT3/8-G1/4	1	Q235A

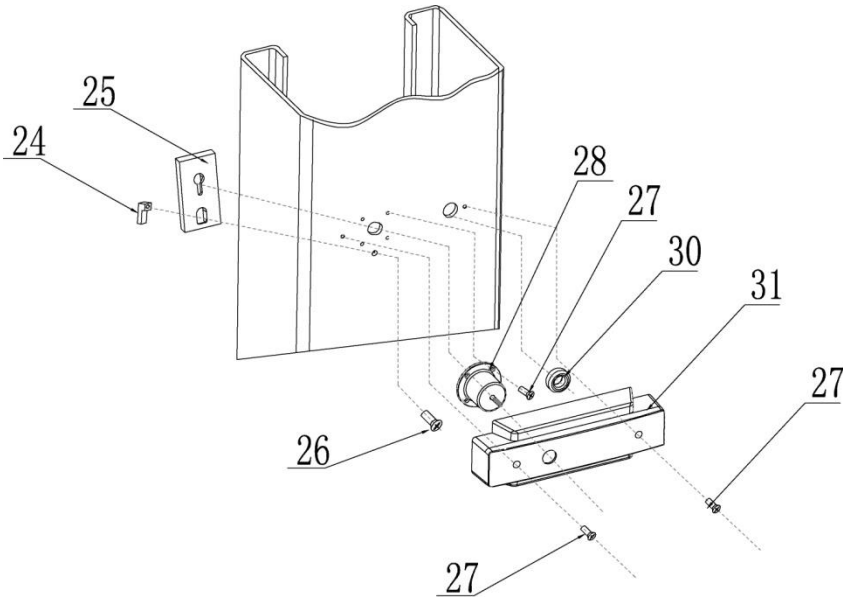

S/N	Name	Drawing-no.	Quantity	Property
24	Orientation block (safety lock)	8224E-A1-B3	4	Zinc-plating
25	Safety locking plate	8224E-A1-B2	4	Zinc-plating
26	M6*16 (cross cap screw)	GB/T818-2000	4	standard
27	M6*10 ( cross cap screw )	GB/T818-2000	24	standard
28	Electromagnet MQZ2-10	8224E-A1-B4	4	assembly
30	Ø20 hose protection ring	8224E-A1-B6	4	rubber
31	Electromagnet cover	8224E-A1-B5	4	plastic

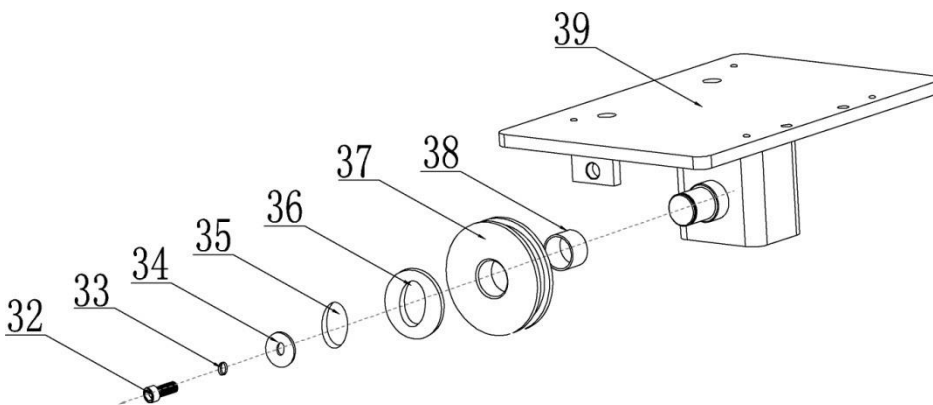

S/N	Name	Drawing-no.	Quantity	Property
32	M8*20 (inside hex cap screw)	GB/T70.2-2000	2	standard
33	M8 (spring washer)	GB/T93-1987	2	standard
34	Retaining ring	8226E-A5-B3	2	Zinc-plating
35	Type B circlip 25	GB/T894.2-1986	2	standard
36	Washer	8224-A1-B3-C2	2	Zinc-plating
37	Pulley (upper)	8225E-A1-B2	2	Zinc-plating
38	Bearing 2519	SF-1	2	standard
39	Top plate	8225E-A1-B3-C1	2	welded

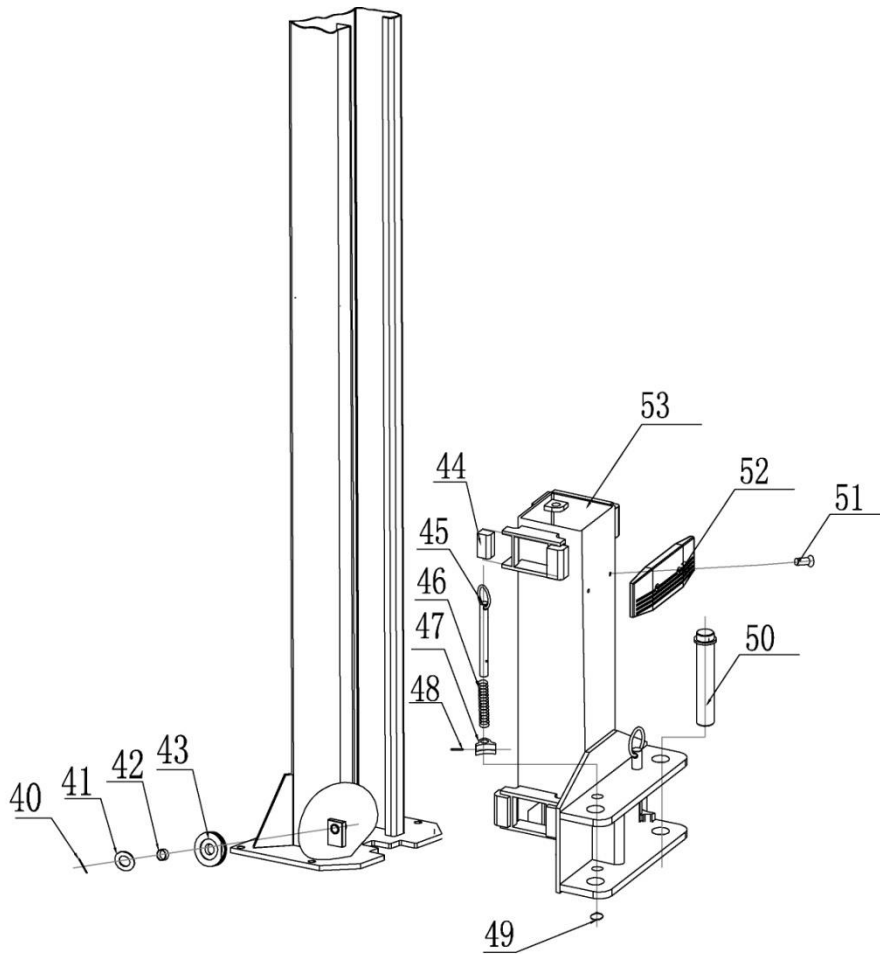

S/N	Name	Drawing-no.	Quantity	Property
40	Cotter pin $\varnothing 2.5 \times 30$	GB/T91-2000	4	standard
41	Washer		4	Zinc-plating
42	Bearing 2518	SF-1	4	standard
43	Pulley (lower)	8225E-A1-B2	4	Zinc-plating
44	Slider	8224-A3-B6	16	Nylon
45	Pulling rod	8225E-A3-B4	4	Zinc-plating
46	Pressure spring	8224-A3-B5	4	Zinc-plating
47	Teeth block	8225E-A3-B4	4	Zinc-plating
48	Spring pin 5*35	GB/T879.1-2000	4	standard
49	Type B circlip 22	GB/T894.2-1986	4	standard
50	Shaft	8225E-A12	4	Zinc-plating
51	M8*16 cross sunken head screw	GB/T819.1-2000	4	standard
52	Rubber pad (door protection)	8225E-A3-B3	2	rubber
53	Carriage	8226E-A3-B1	2	welded

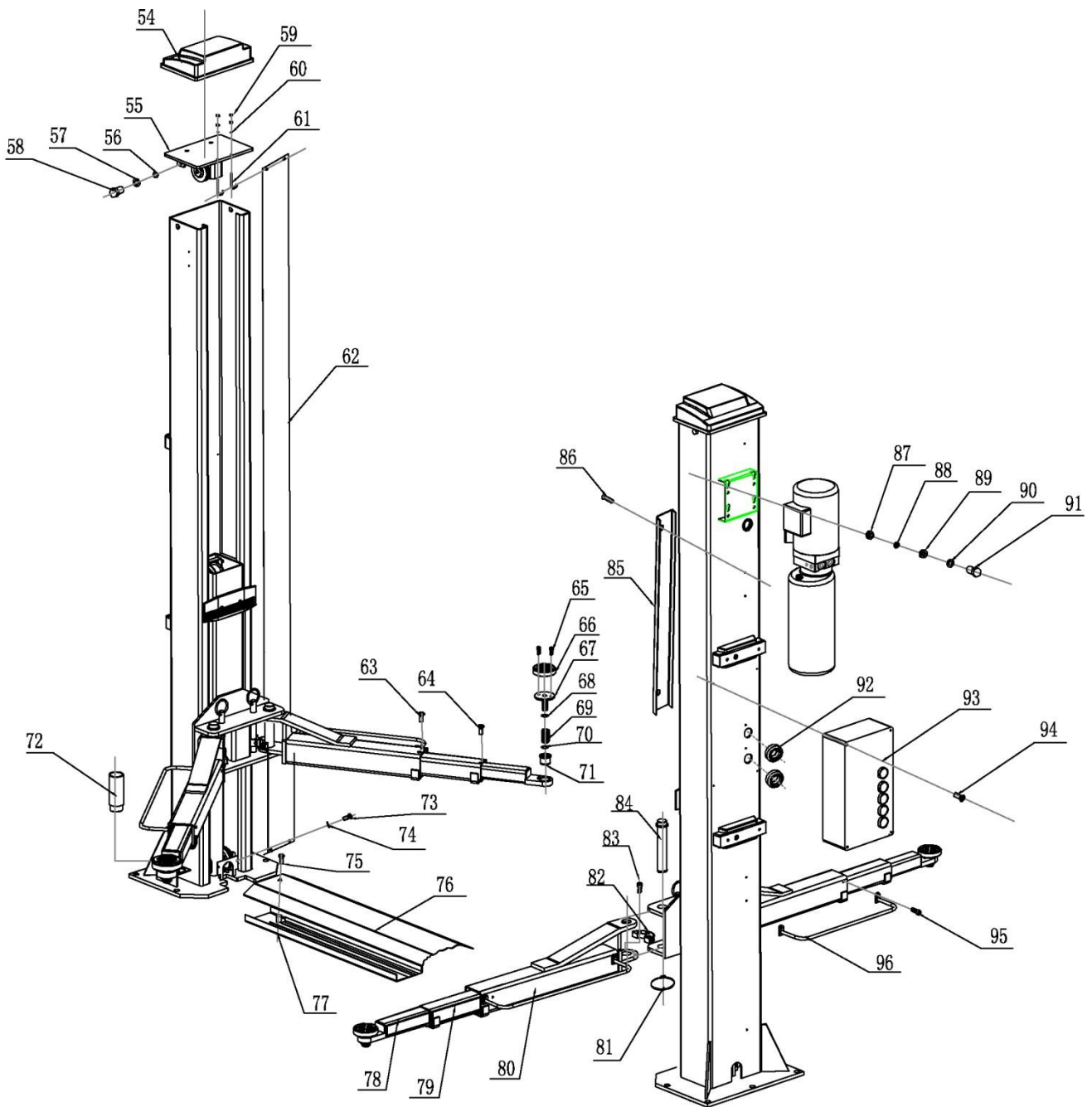





S/N	Name	Drawing-no.	Quantity	Property
54	Top cap	8225E-A1-B4	2	plastic
55	Top plate	8225E-A1-B3-C1	2	assembly
56	M12 washer (flat)	GB/T95-1985	6	standard
57	M12 spring washer	GB/T93-1987	6	standard
58	M12*20 hex head screw	GB/T5781-2000	6	standard
59	M6 hex nut	GB/T6170-2000	8	standard
60	M6 washer (flat)	GB/T95-1985	4	standard
61	Threaded hook (protection cloth)	8224-A13	4	standard
62	Protection cloth	2700*180	2	cloth
63	M8*12 cross sunken head screw	GB/T819.1-2000	4	standard
65	M8*20 hex sunken head screw	GB/T70.3-2000	8	standard



S/N	Name	Drawing-no.	Quantity	Property
66	Rubber lifting pad	8225E-A7-B4-C4	4	rubber
67	Lifting tray	8225E-A7-B4-C1	4	welded
68	circlip 35	GB/T895.2-1986	4	standard
69	Swivel sheath (outer)	8225E-A7-B4-C3	4	Zinc-plating
70	circlip 42*2.5	GB/T895.2-1986	8	standard
71	Swivel sheath (inner)	8225E-A7-B4-C2	4	Zinc-plating
72	Height adapter	8225E-A11	4	Zinc-plating
73	M6*8 cross cap screw	GB/T818-2000	4	standard
74	M6 washer (flat)	GB/T95-1985	4	standard
75	M12*16 inside hex sunken screw	GB/T70.3-2000	2	standard
76	Base cover plate	8225E-A9	1	Q235A
77	Slot base plate	8225E-A8	1	welded
78	Short arm	8226E-A5-B3	4	welded
79	Mid arm	8226E-A5-B2	4	welded
80	Lifting arm assembly	8226E-A5-B1	4	welded
81	Type B circlip 38	GB/T894.2-1986	4	standard
82	Semi-teeth block	8225E-A7-B5	4	Q235A
83	M10*35 inside hex cylinder screw	GB/T70.1-2000	12	standard
84	Shaft	8224-A12	4	Zinc-plating
85	Hose protection cover	8224E-A1-B8	6	Q235A
86	Cross cap screw M6*25	GB/T818-2000	12	standard
87	Hex nut M10	GB/T6170-2000	4	standard
88	Spring washer M10	GB/T93-1987	4	standard
89	Anti-short pad	8224-A14	4	rubber
90	Class C flat washer M10	GB/T95-1985	4	standard
91	Hex head full swivel bolt M10*35	GB/T5781-2000	4	standard
92	Φ40 hose protection ring	8224E-A1-B7	2	rubber
93	Control box	8224E-A5	1	assembly
94	Cross cap screw M5*10	GB/T818-2000	4	standard
95	Inside hex cap screw M8*12	GB/T70.2-2000	8	standard
96	Feet protection fender	8224-A8-B3	4	welded

## 13.6. Spare part list

S/N	Name	Spezifikation	Quantity	Picture
1	Main switch	LW26GS-20/04	1	
2	Button	Y090-11BN	1	
3	Power indicator	AD17-22G-AC24	1	
4	Transformer	JBK-160VA380V-24V JBK-160VA220V-24V	1	
5	AC contractor	CJX2-1210/AC24	1	
6	Circuit breaker	DZ47-63 C16/3P DZ47-63 C32/2P	1	
7	Circuit breaker	DZ47-63 C3/1P	1	
8	Limit switch	TZ8108	1	
9	Emergency stop	Y090-11ZS/RED	1	
10	Bridge rectifier	KBPC5A-35A	1	
11	Capacitor	4700UF/50A	1	
12	Relay	LY2NJ/AC24	1	

S/N	Name	Spezifikation	Quantity	Picture
13	Relay holder	PTF-08A	1	
14	Time relay	ST6PA-5S/AC24V	1	
15	Time relay holder	PYF-08AE	1	
16	Control box	260*460*135	1	

Mechanical spare parts:

S/N	Name	Drawing-no.	Quantity	Property
1	Plastic slider	8224-A3-B6	16	Nylon 1010
2	Rubber lifting pad	8225E-A7-B4-C4	4	rubber
3	O-shape seal ring	Inside diameter 23.6*3.55		
4	Y-shape seal ring	SD70*60*8		
5	Anti-dust ring	DHS40(40*48*5/6.5)		



The company

**Twin Busch GmbH | Amperestr. 1 | D-64625 Bensheim**

hereby declares that the **2-post vehicle lift**

**TW 260 + TW 260 B4.5 | 6000 kg**  
(FL-8226E + FL-8216E)

Serial number:

in this configurations we have placed on the marked complies with the relevant essential health and safety requirements of the following EC-directive(s) in its/their current version(s).

EC-directive(s)

**2006/42/EC**

**Machinery**

**2014/35/EU**

**Low Voltage**

Applied harmonized standards and regulations

**EN 1493:2010**

**Vehicle Lifts**

**EN 60204-1:2006/A1:2009**

**Safety of Machinery – Electrical Equipment of Machines**

CE Certificate

**N8MA 093873 0030 Rev. 00**

date of issue: 24.06.2019

**M6A 093873 0029 Rev. 00**

place of issue: München

technical file no.: 646641903201

Certification body

TÜV SÜD Product Service GmbH,

Ridlerstraße 65,

80339 München

Notified Body Appointment No.: 0123

**In the case of improper use, as well as in the case of assembling, modification or changes which are not agreed with us, this declaration will lose its validity.**

Authorized person to compile technical documentation is: Michael Glade (address as below)



**TWIN BUSCH GmbH**

Amperestr. 1 · 64625 Bensheim  
Tel. 06251 / 70585-0 · Fax: 70585-29

Authorized signatory: Michael Glade  
Bensheim, 10.07.2019 Qualitätsmanagement

**Twin Busch GmbH | Amperestr. 1 | D-64625 Bensheim**

twinbusch.de | E-Mail: info@twinbusch.de | Tel.: +49 (0)6251-70585-0



Twin Busch GmbH | Amperestraße 1 | D-64625 Bensheim  
Tel.: +49 (0) 6251-70585-0 | Fax: +49 (0) 6251-70585-29 | [info@twinbusch.de](mailto:info@twinbusch.de)