



TW 250E

Base Plate Two Post Lift
Electrical Release
Lifting Capacity 5000KG

twinbusch.de



Installation, Operation and Parts Manual



Read this entire manual carefully before installation or operation of the lift. Follow the instructions strictly.

Twin Busch GmbH | Amperestraße 1 | D-64625 Bensheim
Tel.: +49 (0) 6251-70585-0 | Fax: +49 (0) 6251-70585-29 | info@twinbusch.de

Please read this entire manual carefully and completely before installation or operation of the lift.

INDEX

1. Important safety instructions.....	3~4
1.1 Important notices	
1.2 Qualified personnel	
1.3 Danger notices	
1.4 Training	
1.5 Warning signs	
2. Overview of the lift.....	5
2.1 General descriptions	
2.2 Technical data	
2.3 Construction of the lift	
3. Installation instructions.....	6~14
3.1 Preparations before installation	
3.1.1 Tools and equipments needed	
3.1.2 A list for parts checking	
3.1.3 Ground conditions	
3.2 Precautions for installation	
3.3 Installation	
3.4 Items to be checked after installation	
4. Operation instructions.....	15~16
4.1 Precautions	
4.2 Flow chart for operation	
4.3 Operation instructions	
5. Trouble shooting.....	17
6. Maintenance.....	18
7. Annex.....	19~35
Annex1, Packing list of the whole lift	
Annex2, Overall diagram	
Annex3, Floor plan	
Annex4, Hydraulic working system	
Annex5, Wiring diagram	
Annex6, Separated drawings for the lift	
Annex7, Spare parts list	

IMPORTANT SAFETY INSTRUCTIONS

1.1 Important notices

FREND will offer one-year's quality warranty for the whole machine, during which any quality problem will be properly solved to the user's satisfaction. However, we will not take any responsibility for whatever bad consequence resulted from improper installation and operation, overload running or unqualified ground condition.

This 2-posts lift is specially designed for lifting motor vehicles that weighs within its outmost lifting capacity. Users are not allowed to use it for any other purposes. Otherwise, we, as well as our sales agency, will not bear any responsibility for accidents or damages of the lift. Make sure to pay careful attention to the label of the lifting capacity attached on the lift and never try to lift cars with its weight beyond.

Read this manual carefully before operating the machine so as to avoid economic loss or personnel casualty incurred by wrong operation. Without professional advice, users are not permitted to make any modification to the control unit or whatever mechanical unit.

1.2 Qualified personnel

1.2.1 Only these qualified staff, who have been properly trained, can operate the lift.

1.2.2 Electrical connection must be done by a competent electrician.

1.2.3 People who are not concerned are not allowed in the lifting area.

1.3 Danger notices

1.3.1 Do not install the lift on any asphalt surface.

1.3.2 Read and understand all safety warnings before operating the lift.

1.3.3 The lift, if is not specially designed upon customer's request, is not fit for outdoor use.

1.3.4 Keep hands and feet away from any moving parts. Keep feet clear of the lift when lowering.

1.3.5 Only these qualified people, who have been properly trained, can operate the lift.

1.3.6 Do not wear unfit clothes such as large clothes with flounces, tires, etc, which could be caught by moving parts of the lift.

1.3.7 To prevent evitable incidents, surrounding areas of the lift must be tidy and with nothing unconcerned.

1.3.8 The lift is simply designed to lift the entire body of vehicles, with its maximum weight within the lifting capacity.

1.3.9 Always insure the safety latches are engaged before any attempt to work near or under the vehicle.

1.3.10 Make sure to place the lifting pads to the positions as suggested by vehicle makers and when gradually lift the vehicle to the desired height, operators should be certain that the vehicle will not slant, roll-over or slide in lifting process.

1.3.11 Check at any time the parts the lift to ensure the agility of moving parts and the performance of synchronization. Ensure regular maintenance and if anything abnormal occurs, stop using the lift immediately and contact our dealers for help.

1.3.12 Lower the lift to its lowest position and do remember to cut off the power source when service finishes.

1.3.13 Do not modify any parts of the lift without manufacturer's advice.

1.3.14 If the lift is going to left used for a long time, users are required to:

- a. Disconnect the power source;
- b. Empty the oil tank;
- c. Lubricate the moving parts with hydraulic oil.

1.4 Training

Only these qualified people, who have been properly trained, can operate the lift. We are quite willing to provide professional training for the users when necessary.

Attention: For environment protection, please dispose the disused oil in a proper way.

1.5 Warning signs

All safety warning signs attached on the machine are for the purpose of drawing the user's attention to safety operation. The labels must be kept clean and need to be replaced when they are worn-out or have dropped. Read the explanations of the labels carefully and try to memorize them.

<p>ATTENTION!</p> <p>Please read the instruction manual and safety warnings before using!</p>	<p>ATTENTION!</p> <p>Use of the lift by qualified personnel only!</p>	<p>ATTENTION!</p> <p>Use only the vehicle manufacturer's recommended lifting points!</p>	<p>ATTENTION!</p> <p>Check vehicle for security shortly after lifting!</p>
<p>ATTENTION!</p> <p>Repairs and maintenance only by qualified personnel, do not tamper with lift safety devices!</p>	<p>ATTENTION!</p> <p>Only qualified personnel are allowed within the lift working area!</p>	<p>ATTENTION!</p> <p>Never exceed the recommended lifting capacity!</p>	<p>ATTENTION!</p> <p>Attention when removing heavy vehicle parts!</p>
<p>ATTENTION!</p> <p>Always keep escape routes free!</p>	<p>ATTENTION!</p> <p>No persons under the lift (when lifting or lowering)!</p>	<p>ATTENTION!</p> <p>Never try to lift using only one side of the lift!</p>	<p>ATTENTION!</p> <p>Protect the lift against damp, especially the electrical connections!</p>
<p>ATTENTION!</p> <p>Always take care of your feet when lowering!</p>	<p>ATTENTION!</p> <p>Never climb on the lift!</p>	<p>ATTENTION!</p> <p>Avoid excessive shaking of the vehicle!</p>	<p>ATTENTION!</p> <p>Danger of shock!</p>

OVERVIEW OF THE LIFT

2.1 General descriptions

This floor plate two posts lift is composed of posts, carriages, lifting arms, cylinders and motor unit, etc.

It is driven by an electro-hydraulic system. The gear pump delivers hydraulic oil to oil cylinders and pushes upwards its piston. The piston drives the chain to raise the carriage and the lifting arms. During lifting process, the safety latch will automatically and firmly bite with the safety teeth block in the posts. Therefore, no slipping will happen in case the hydraulic system breaks down.

Safety structure

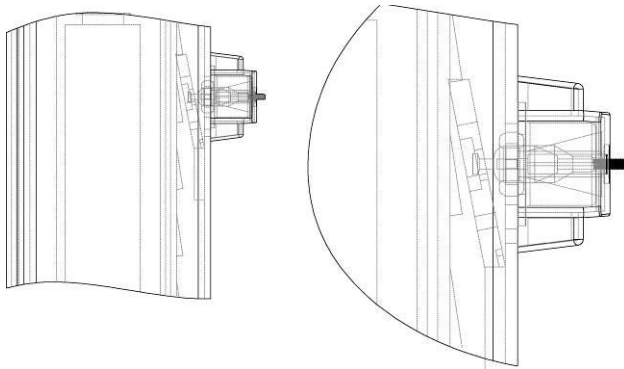

2.2 Technical data

Model	Lifting capacity	Lifting time	Lifting height	Height	Width	Width between posts
TW 250E	5000kg	50 Sec	1900mm	2912mm	4028mm	3342mm

2.3 Construction of the lift

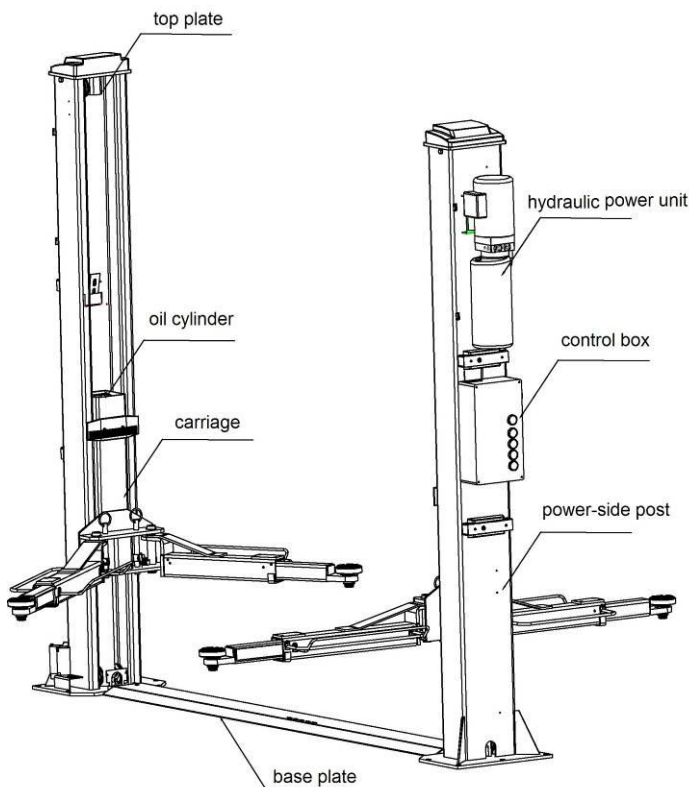

INSTALLATION INSTRUCTIONS

3.1 Preparations before installation

3.1.1 Tools and equipments needed

- ✓ Appropriate lifting equipment
- ✓ Anti-abrasion hydraulic oil.
- ✓ Rotary Hammer Drill with 3/4" drill bit.
- ✓ Chalk and tape measure, magnetic plump, 8 metersΦ15 level pipe.
- ✓ Sockets and open wrenches, a set of inside hex wrenches, cross and straight screw drivers.
- ✓ Hammer, 4pounds, sharp nose pliers, Φ17,Φ19,Φ22 socket spanners.

3.1.2 List for parts checking ---Annex 1 (Packing list)

Unfold the package and check if any parts missed as per Annex 1. Do not hesitate to contact us in case any parts missed, but if you do not contact us and insist installing upon the lack of some parts, FRLEND as well as our dealers will not bear any responsibility for this and will charge for any parts subsequently demanded by the buyer.

3.1.3 Ground conditions

The lift should be fixed on a smooth and solid concrete ground with its strength more than 3000psi, tolerance of flatness less than 5mm and minimum thickness of 200mm. In addition, newly built concrete ground must undergo more than 28days' cure and reinforcement.

3.2 Precautions for installation

3.2.1 Make sure the two posts stand paralleled and are vertical to the ground. No slanting.

3.2.2 Joints of oil hose and steel cable must be firmly connected in order to avoid the looseness of steel cable and leakage of oil hose.

3.2.3 All bolts should be firmly screwed up.

3.2.4 Do not place any vehicle on the lift in the case of trial running.

3.3 Installation

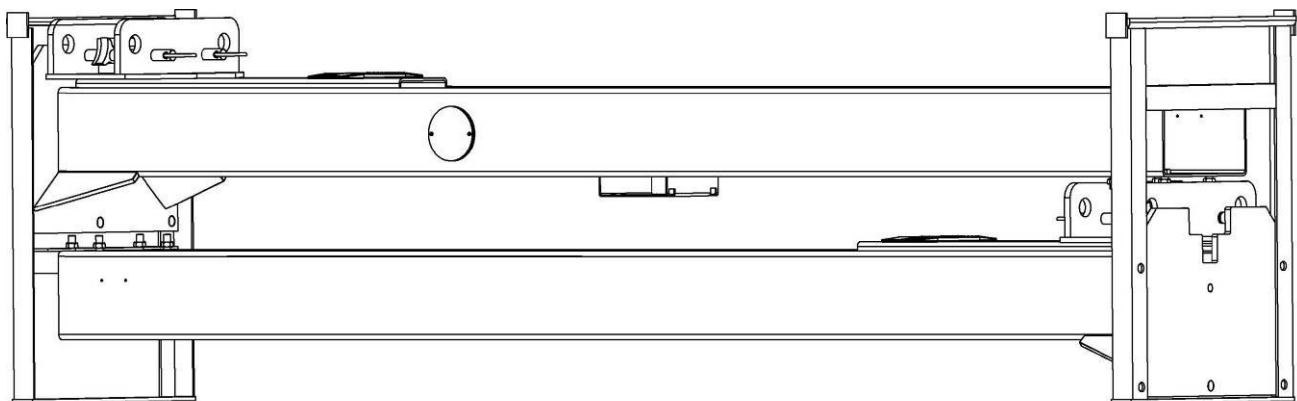

Step 1: Remove the packaging, take out the carton for accessories and cover plate.

Step 2: Firstly, put something supporting between the two posts or suspend one of the posts by a crane and then remove the bolts on the package.

Attention : Please pay special attention not to let the post fall down for it may cause casualty or bring damages to the accessories fixed in the post.

Step3: When the first post has been taken away, place something supporter under the second post and then remove the bolts on the package.

Step 4: Fix the standing position for the two posts. (see Annex 3, floor plan)

1. Unfold the package and decide on which post the power unit will be mounted.
2. Draw an outline of the base plate on the ground with chalk and ascertain the position for the post.

Step 5: Erect the posts, power side post first and then the other post.

1. Drill anchor holes for expansion bolts on the ground with an electrical drill. Make sure to drill vertically.
2. After holes have been drilled, remove thoroughly the debris and dust in them and ascertain that the posts stay upon the circle previously drawn by chalk.

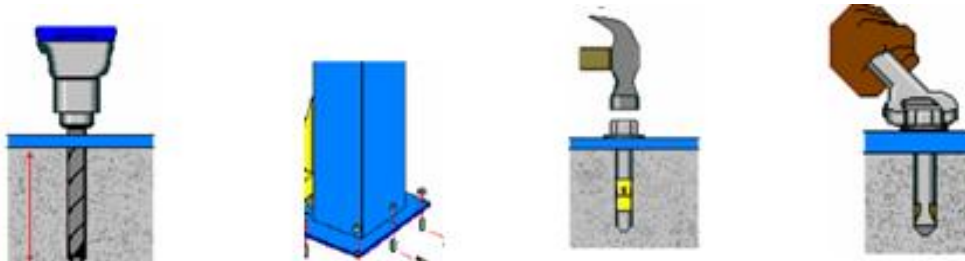

Step 6: Fix mechanical safety lock assemblies.

Fix four safety locking plates and electro-magnets with two of them on each post.

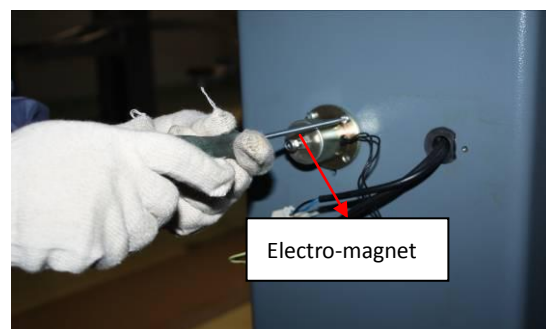
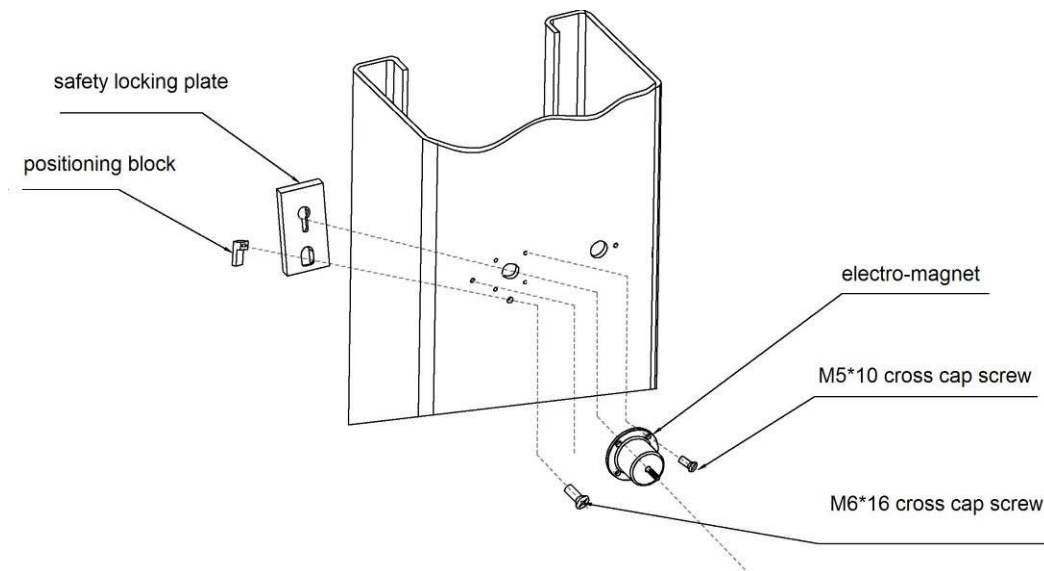

Step 7: Fix the slot base plate.

Manually raise two carriages about 800mm from the ground to have them locked by safety locks and then place the slot base plate

between two base plates of the post.

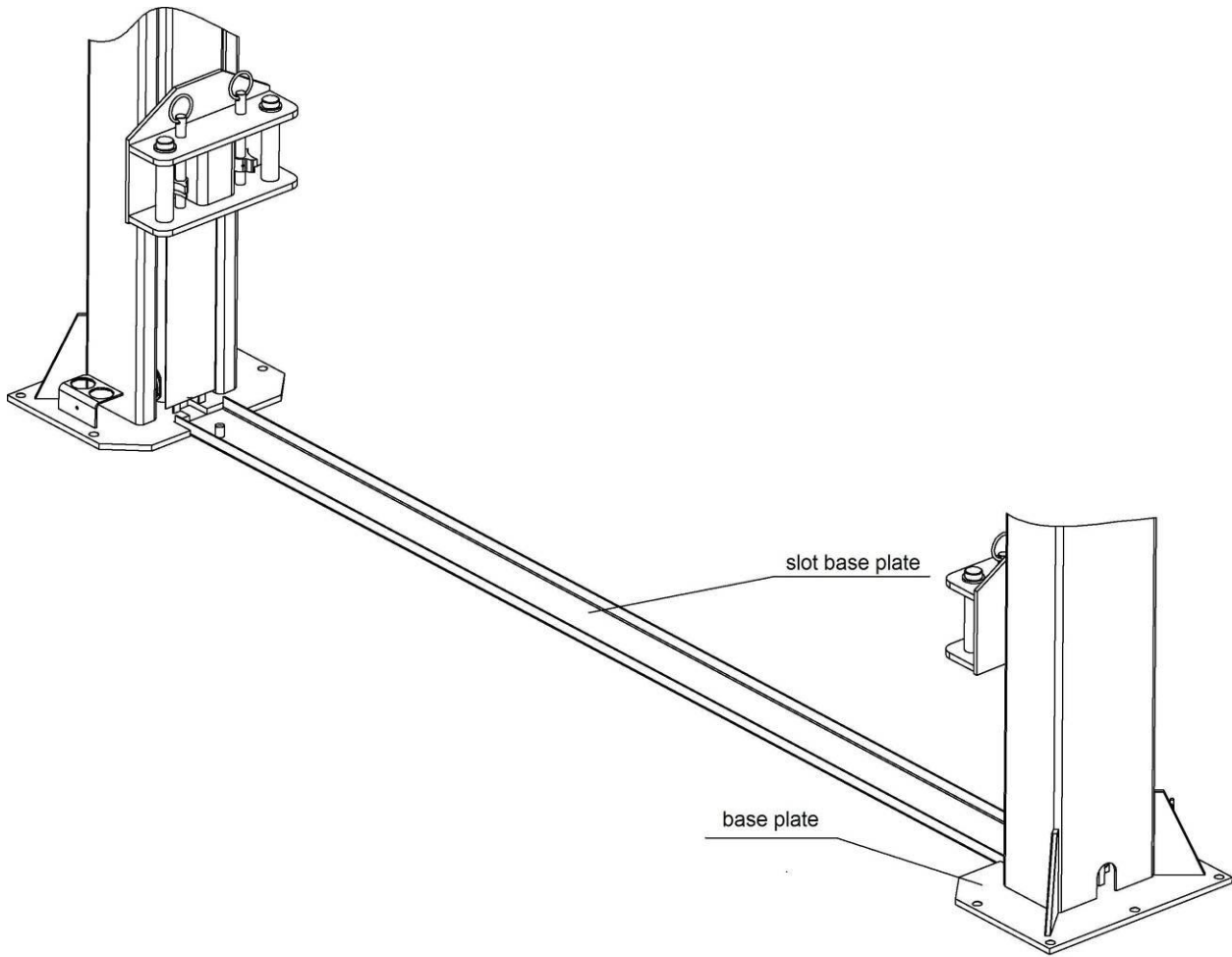

Step8: Connect steel cables.

1. Route and fix according to the following diagram of steel cable connection.
2. Raise carriages on both sides approximately 800mm above the ground. Carriages must be on the same height from the floor.
3. Make sure that the mechanical safety locks in each post are fully engaged before attempting to route cables.
4. After the cable being fixed, adjust and make the cable at both sides be with the same tightness which could be judged by the sound emitted during lifting process. Make judge and adjustment after trial running.
5. Grease after being fixed. (It is a must.)

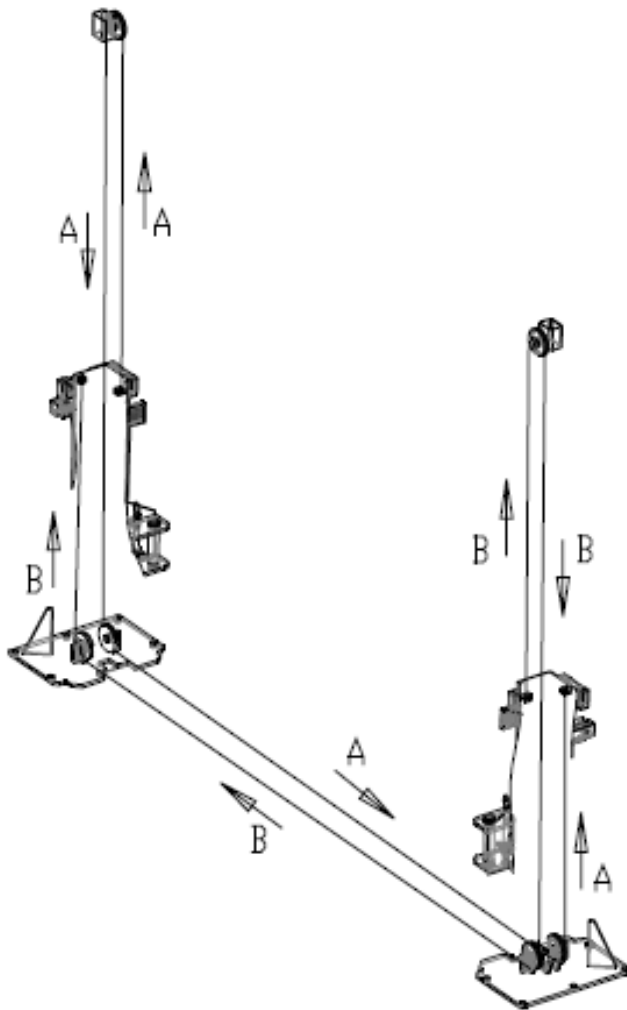

Step9: Mount the power unit onto the power side post.

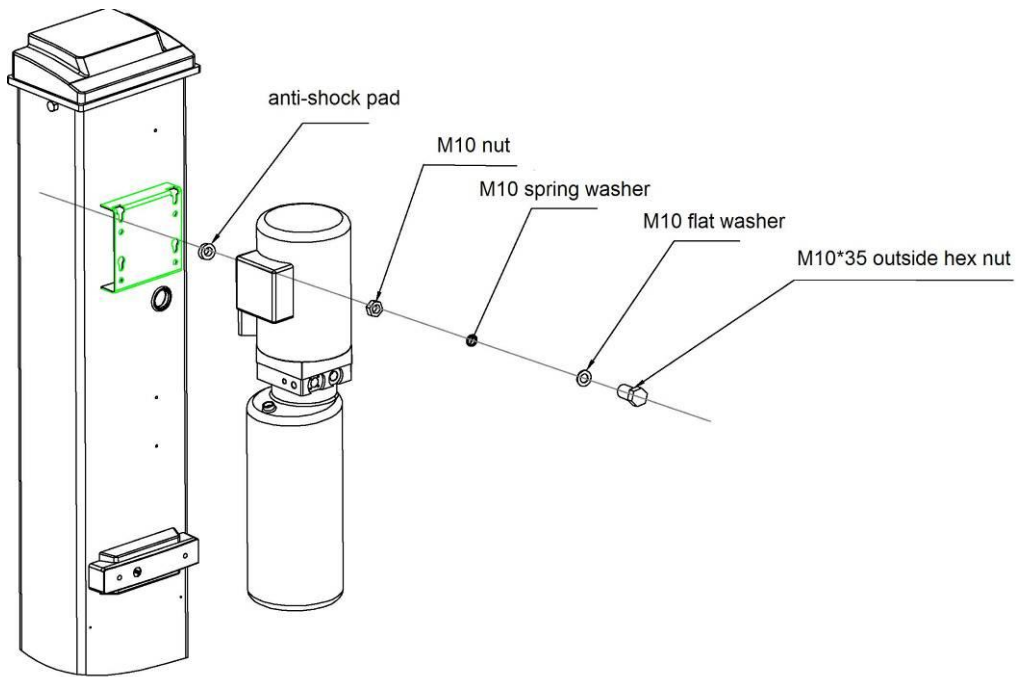

Step10: Connect oil hoses.

Connect the oil hose as per the following diagram.

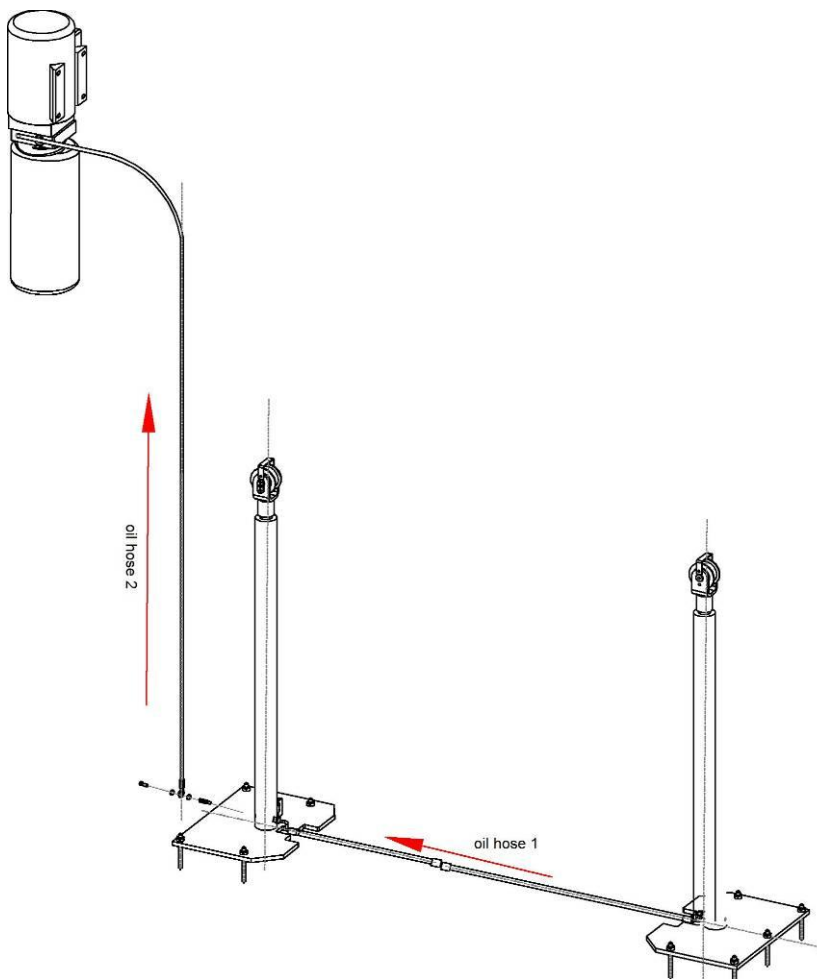

Step11: Connect wires.

1. Mount the control box on to the power side post.

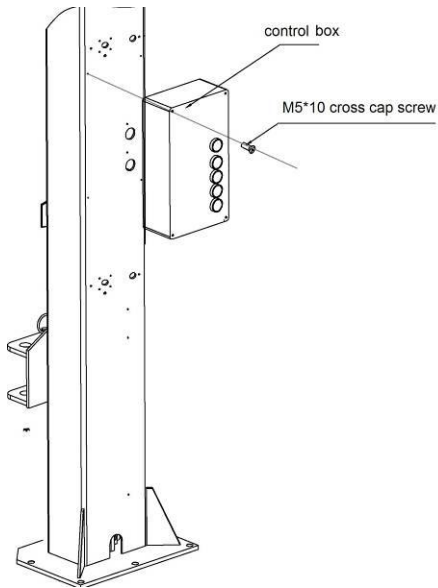

2. Fix the limit switch into the power side post.

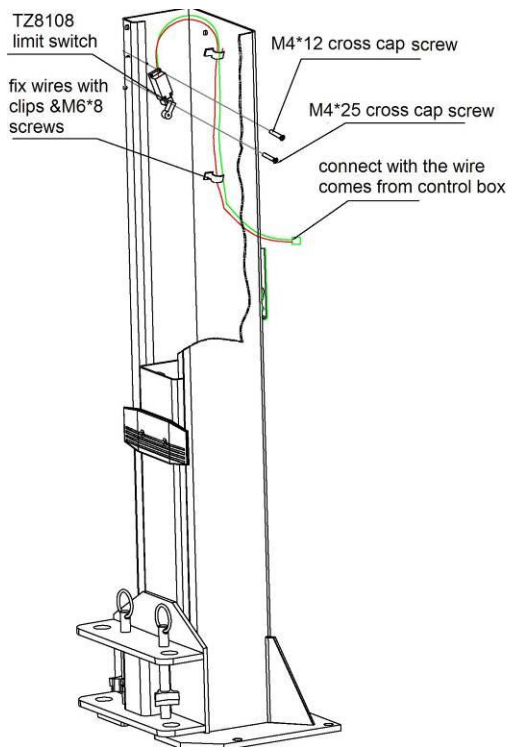

3. Connect quick connectors between electromagnets.



Quick connectors



Adjustable bolt

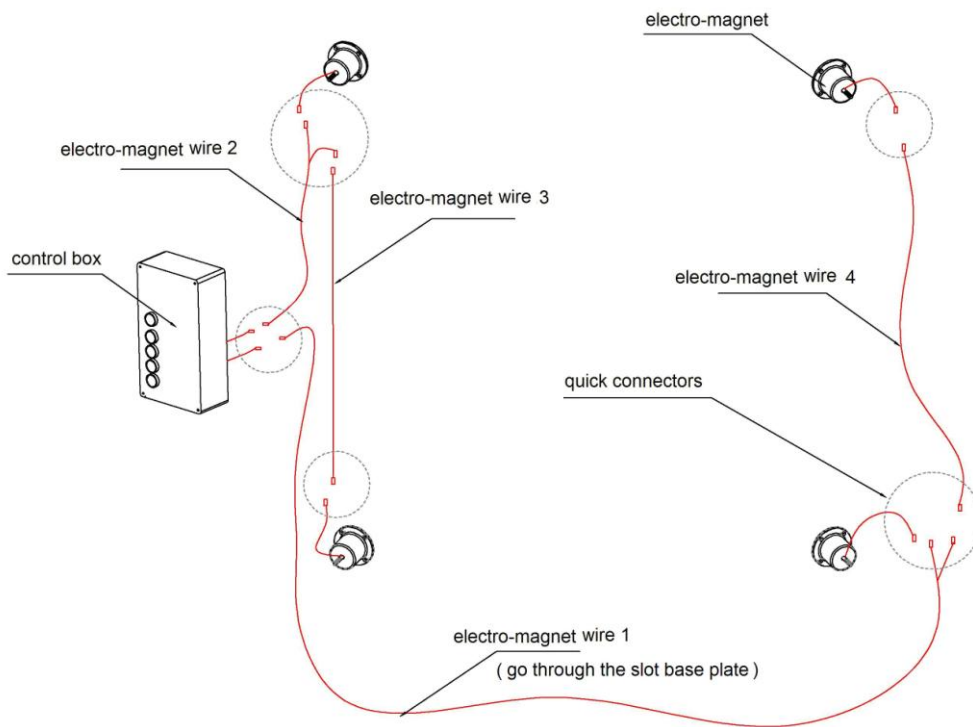

4 . Connect the wire of solenoid valve and motor wire

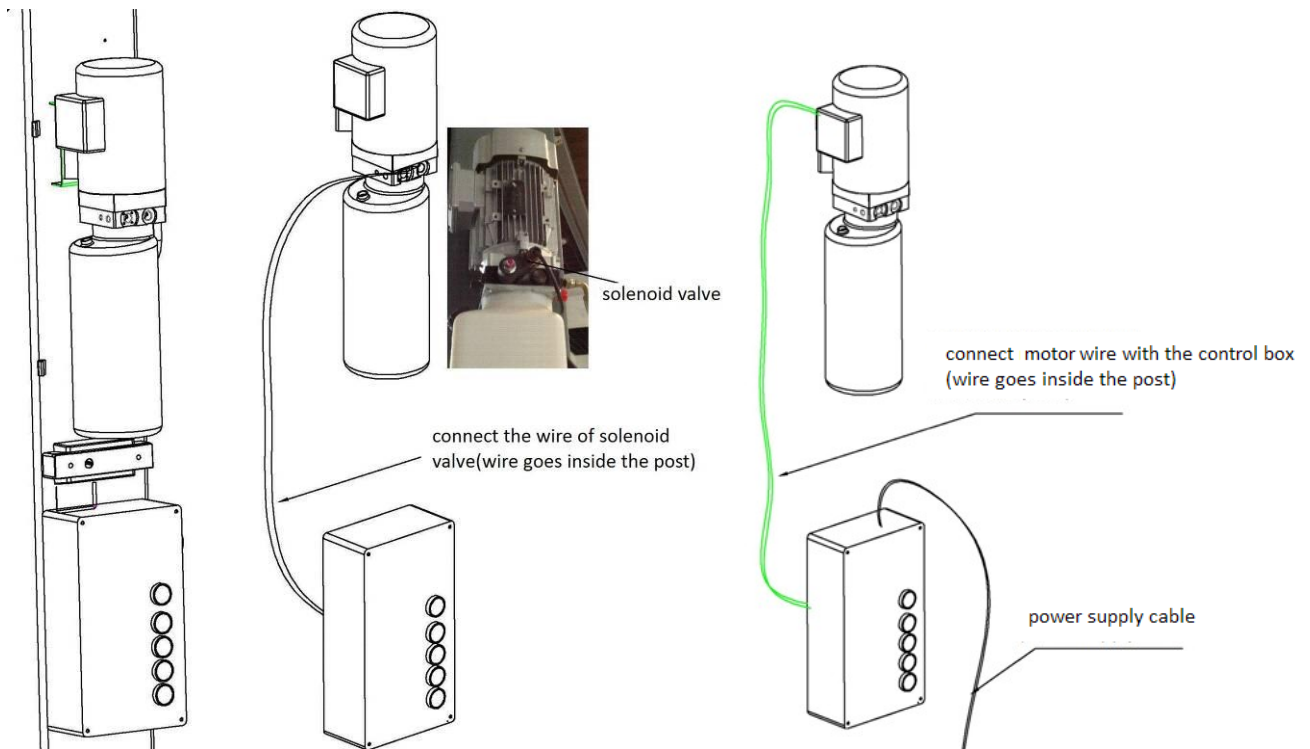

Step 12: Fix wire & oil hose protectors.

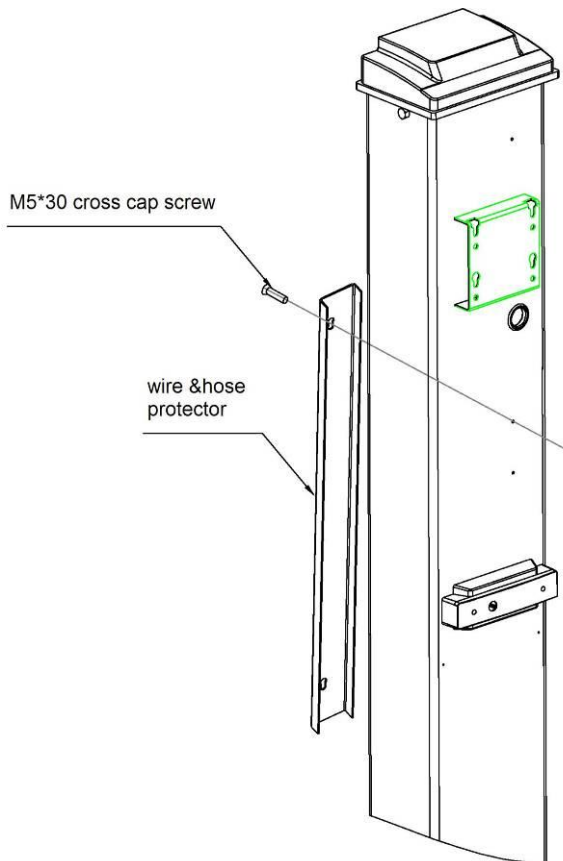

Step13: Install lifting arms.

Connect the lifting arm and the carriage by shafts.

Install the lifting arms onto the carriages and ensure the arm lock could work.

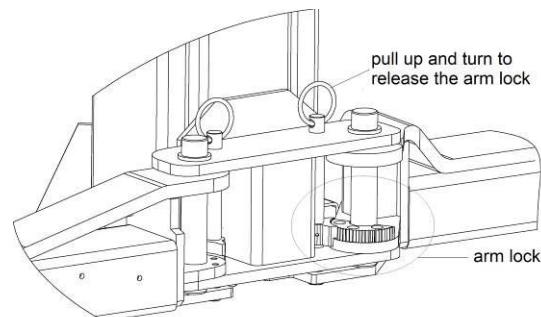
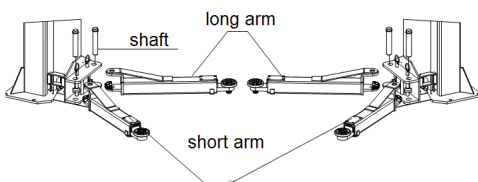

Step14: Fill with hydraulic oil.

The volume of oil tank is 10L. To insure the lift work normally, the amount of oil in it should reach 4/5 of the tank's total volume. 32# anti-abrasion hydraulic oil for winter, 46# for summer.

Step15: Trial running.

1. Do refer to the operation instructions in advance and keep in mind that no vehicle left on the lift in the process of trial running.
2. Check if all the connections are in good condition.

Step16: Fix feet protection fenders, chain protection clothes, electro-magnet protection covers, door-opening protections, top caps and lifting trays.

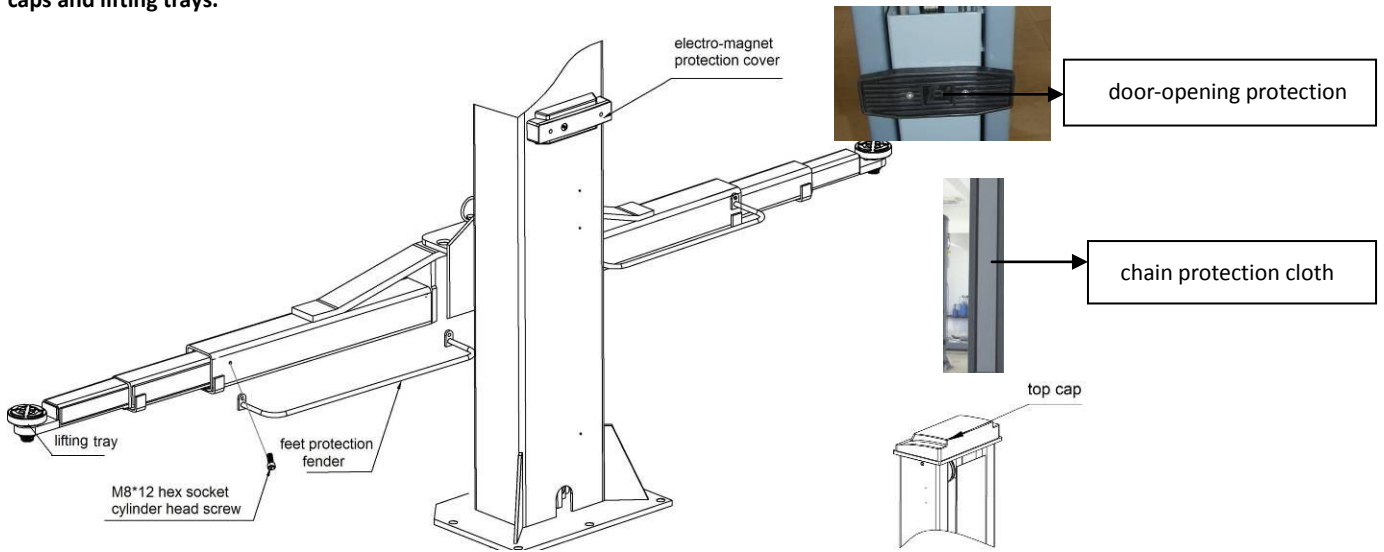

Step17: Fix base cover plate.

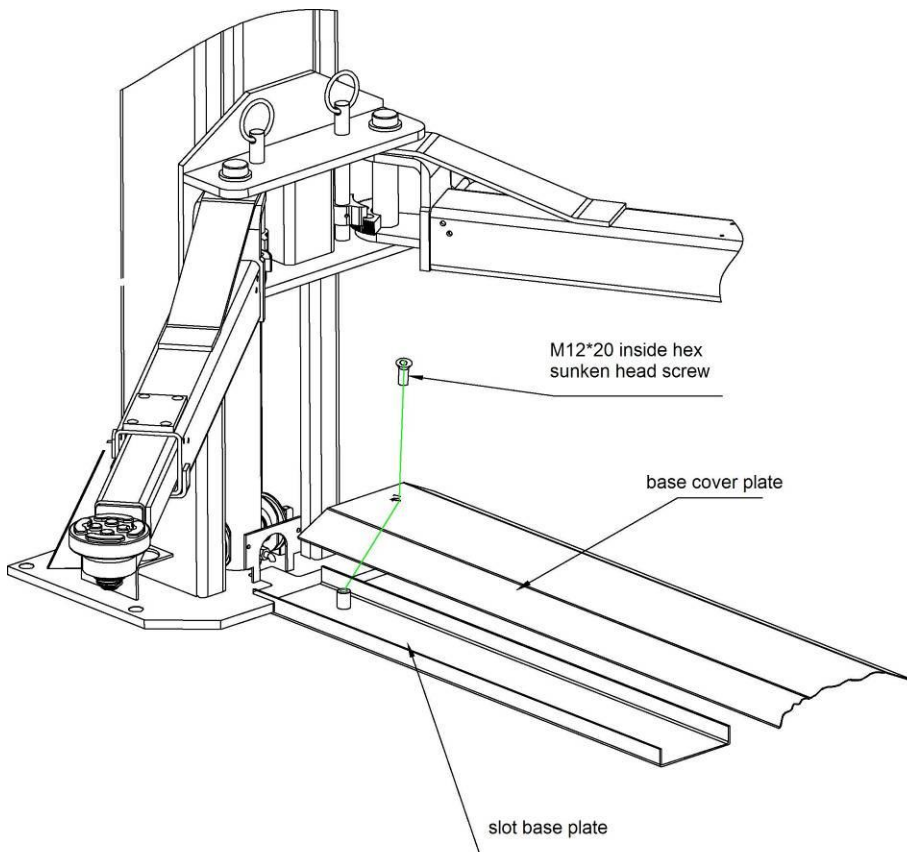

3.4 Items to be checked after installation.

S/N	Check items	YES	NO
1	Are the posts vertical to the floor?		
2	Are the two posts paralleled?		
3	Are oil hoses well connected?		
4	Are steel cables well connected?		
5	Are all lifting arms well fixed?		
6	Are electrical connections right?		
7	Are the rest joints firmly screwed?		
8	Are all items need lubricating added with grease?		

OPERATION INSTRUCTIONS

4.1 Precautions

4.1.1 Check all the joints of oil hose. Only when there is no leakage, the lift can start work.

4.1.2 The lift, if its safety device malfunctions, shall not be used.

4.1.3 The machine shall not lift or lower an automobile if its center of gravity is not positioned midway of the swing arms. Otherwise, the FRLIND as well as our dealers will not bear any responsibility for any consequence resulted thereby.

4.1.4 Operators and other personnel concerned should stand in a safety area during lifting and lowering process.

4.1.5 When lifting arms rise to the desired height, switch off the power at once to prevent any mal-operation done by unconcerned people.

4.1.6. Make sure the safety lock of the lift is engaged before start working under the vehicle and no people under the vehicle during lifting and lowering process.

4.2 Flow chart for operation

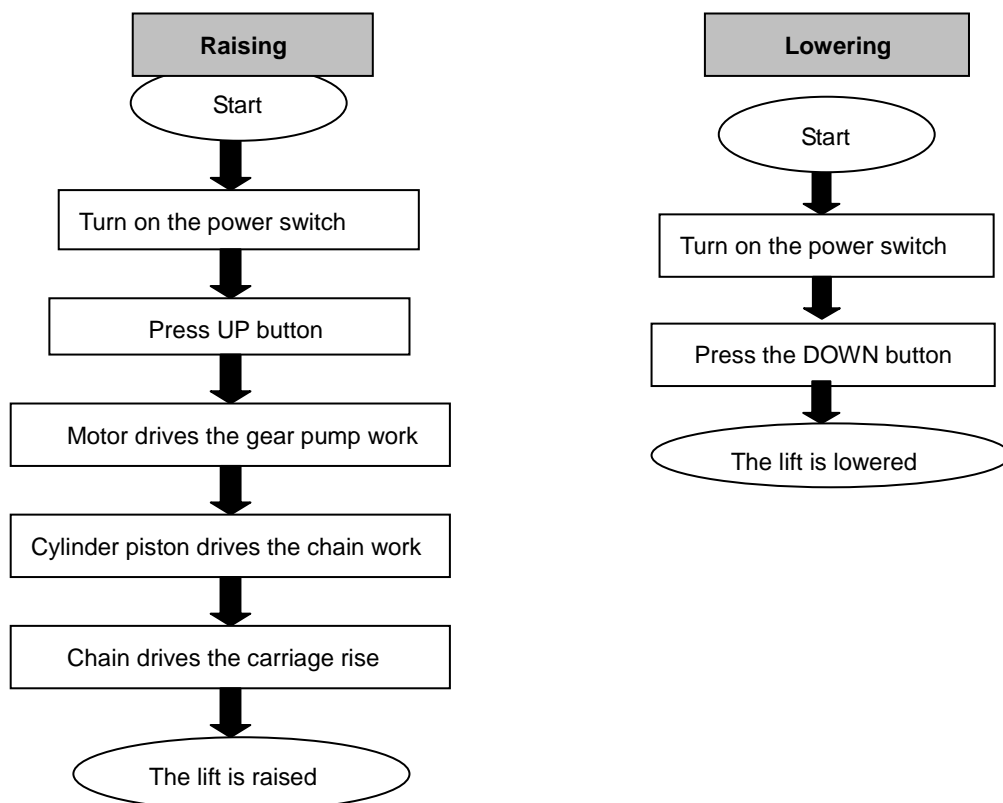

4.3 Operation instructions

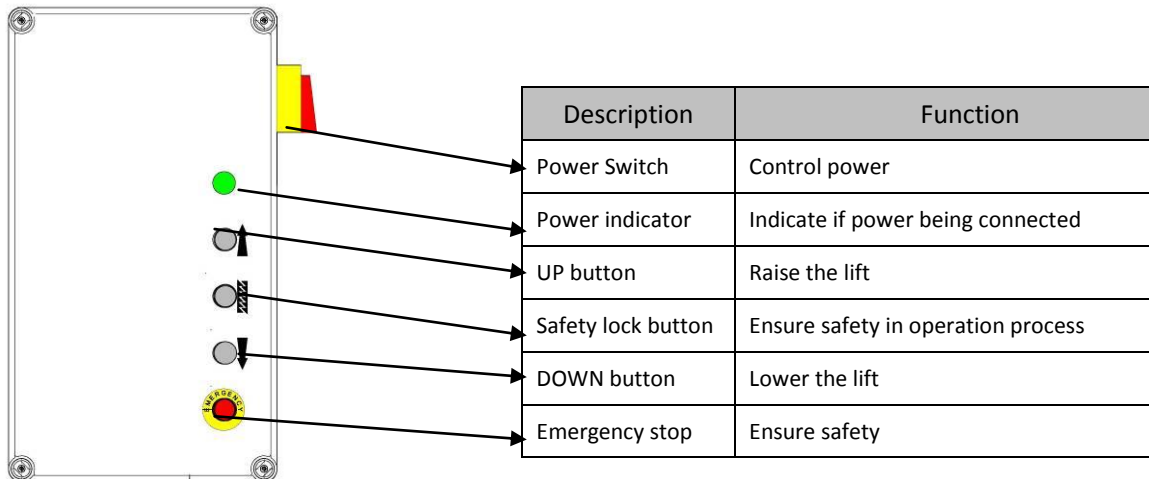

Raise the lift

1. Make sure that you have read and understood the operation manual before operation.
2. Park the vehicle between two posts.
3. Adjust the lifting arms until they reach the supporting positions of the vehicle and make sure the gravity of vehicle located in the center of four lifting arms.
4. Connect the power supply as per requirements on the nameplate attached. and switch on.
5. Press the "UP" button on the control box until pads of lifting arms touched the prop-position of vehicle.
6. Keep on raising the vehicle to let it have a bit clearance from the ground and check again its stability.
7. Raise the vehicle to the desired height, check it is safe or not, press the "Safety Lock" button on the control panel to have the safety lock engaged, turn off the power and then perform maintenance or repair work underneath.

Lower the lift

1. Switch on.
2. Press the "DOWN" button on the control box. Meanwhile the lifting arms automatically go upwards about 5CM which releases the safety lock. The lift lowers.
3. After the lifting arms lower to the lowest position, pull them out from under the vehicle and clear up all the obstacles.
4. Drive the vehicle away.

TROUBLE SHOOTING

ATTENTION: If the trouble could not be fixed by yourself, please do not hesitate to contact us for help .We will offer our service at the earliest time we can. By the way, troubles could be judged and solved much faster if more details or pictures could be provided.

TROUBLES	CAUSE	SOLUTION
Abnormal noise	Abrasion exists on insider surface of the posts.	Grease the inside of the post.
	Trash in the post.	Clear the trash
Motor does not run and will not rise	The wire connection is loose.	Check and make a good connection.
	The motor is blown.	Replace it.
	The limit switch is damaged or the wire connection is loose.	Connect it or adjust or replace the limit switch.
Motor runs but will not raise	The motor run reversely.	Check the wire connection.
	Overflow valve is loose or jammed.	Clean or adjust it.
	The gear pump is damaged.	Replace it.
	Oil level is too low.	Add oil.
	The oil hose became loose or dropped off.	Tighten it.
	The cushion valve became loose or jammed.	Clean or adjusts it.
Carriages go down slowly after being raised	The oil hose leaks.	Check or replace it.
	The oil cylinder is not tightened.	Replace the seal.
	The single valve leaks.	Clean or replace it.
	Solenoid valve fails to work well.	Clean or replace it.
	Steel cable is loose or not with same tightness	Check and adjust the tightness.
Raising too slow	The oil filter is jammed.	Clean or replace it.
	Oil level is too low.	Add oil.
	The overflow valve is not adjusted to the right position.	Adjust it.
	The hydraulic oil is too hot (above 45°) .	Change the oil.
	The seal of the cylinder is abraded.	Replace the seal.
	Inside surface of the posts is not well greased.	Add grease.
Lowering too slow	The throttle valve jammed.	Clean or replace.
	The hydraulic oil is dirty.	Change the oil.
	The anti-surge valve jammed.	Clean it.
	The oil hose jammed.	Replace it.
The steel cable is abraded	No grease when installation or out of lifetime	Replace it.

MAINTENANCE

Easy and low cost routine maintenance can ensure the lift work normally and safely. Following are requirements for routine maintenance. Frequency of routine maintenance is determined by working condition and frequency.

THE FOLLOWING PARTS ARE NEEDED TO BE LUBRICATED

S/N	Description
1	Upper wheel
2	Steel cable
3	Chain wheel
4	Chain
5	Sliding block
6	Pin
7	Arm block
8	Lifting arm
9	Tray
10	Down wheel

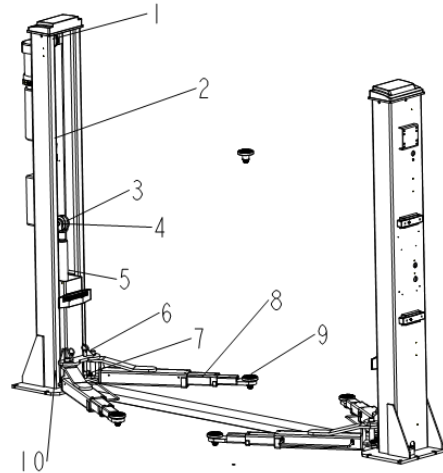

6.1. Daily checking items before operation

The user must perform daily check. Daily check of safety lock system is very important – the discovery of device failure before action could save time and prevent great loss, injury or casualty.

- Before operation, judge whether the safety locks are engaged by sound.
- Check whether oil hose well connected and whether it leaks or not.
- Check the connections of chain and steel cable and check the power unit.
- Check whether expansion bolts are firmly screwed.
- Check if arm lock works well or not.

5.2. Weekly checking items

- Check the flexibility of moving parts.
- Check the working conditions of safety parts.
- Check the amount of oil left in the oil tank. Oil is enough if the carriage can be raised to highest position. Otherwise, oil is insufficient.
- Check whether expansion bolts are firmly screwed.

6.3. Monthly checking items

- Check whether expansion bolts are firmly screwed.
- Check the tightness of the hydraulic system and screw firm the joints if it leaks.
- Check the lubrication and abrasion circumstance of axial pins, carriages, lifting arms and other related parts and replace in time with new ones if they failed to work well.
- Check the lubrication and abrasion circumstance of steel cable.

6.4. Yearly checking items

- Empty the oil tank and check the quality of hydraulic oil.
- Wash and clean the oil filter.

If users strictly follow the above maintenance requirements, the lift will keep in a good working condition and meanwhile accidents could be avoided to a large extent.

ANNEX

Annex 1, Packing List of the whole lift

S/N	Material #	Name	Drawing#	Property	Qty
1		Power side post assembly	FL-8225E-A1	Assembly	1
2		Post assembly	FL-8225E-A2	Assembly	1
3		Carriage assembly	FL-8225E-A3	Assembly	2
4		Lifting arms	FL-8225E-A4	Assembly	4
6		Slot base plate assembly	FL-8225E-A9	Powder coating parts	1
7		Base cover plate	FL-8225E-A10	Powder coating parts	1
8		Power system		Assembly	
9		Control box		Assembly	1
10		A package of electromagnet		Package	1
11		Power unit		Assembly	1
12		Top cap	FL-8225E-A1-B4	ABS	2
Parts in the carton					
	614013009	Feet protection fenders	FL-8224-A8-B3	Powder coating parts	4
	612013001	Lifting trays	FL-8225E-A7-B41	Assembly	4
	615013002B	Protection cloth	FL-8225E-A10	Assembly	2
	624001065	Rubber oil hose L=3380mm		Assembly	1
	612015005	Shafts	FL-8224-A12	zinc-plating parts	4
	410040061	Safety locking plate	FL-8224E-A1-B2	45#	4
	420040060	Electromagnet cover	FL-8224E-A1-B5	ABS	4
	612004003	Height adapter	FL-8225E-A11	Welding assembly	4
	410040071	Orientation block	FL-8224E-A1-B3	Q235A	4
	410040023	Hose and line cover	FL-8224E-A1-B8	Q235A	6
	410010051	Rod of protection cloth	FL-8224-A1-B13	Q235A	4
	201102020	Hex head full swivel screw	M8*35	Standard parts	4
	202111014	Inside hex sunken head screw	M12*20	Standard parts	2
	202110004	Hex socket cylinder head screw	M8*12	Standard parts	8
	202101021	Cross cap screw	M5*10	Standard parts	24
	202101025	Cross cap screw	M5*23	Standard parts	12
	202101027	Cross cap screw	M6*8	Standard parts	4
	202101031	Cross cap screw	M6*16	Standard parts	4
	202103021	Cross cap screw	M8*16	Standard parts	4
	204101004	Class C flat washer	Φ6	Standard parts	8
	204101006	Class C flat washer	Φ8	Standard parts	4
	204201005	Spring washer	Φ8	Standard parts	4
	203101004	Hex nut	M6	Standard parts	8
	203101006	Hex nut	M8	Standard parts	4
	204301013	Type B circlip	Φ38	Standard parts	4
	201201008	Expansion bolt	M18*180	Standard parts	12

Annex2, Overall diagram

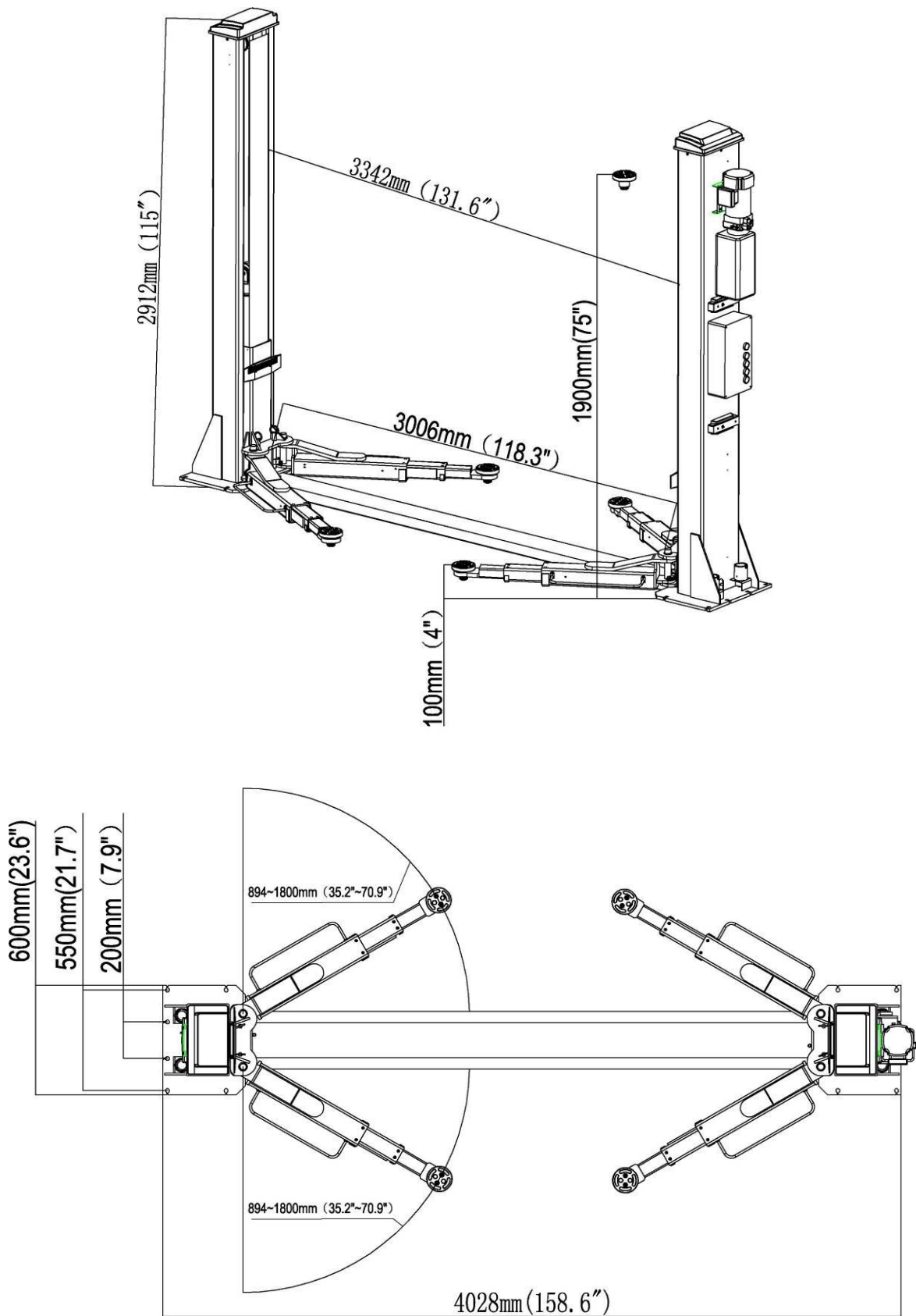

Annex 4, Hydraulic working system

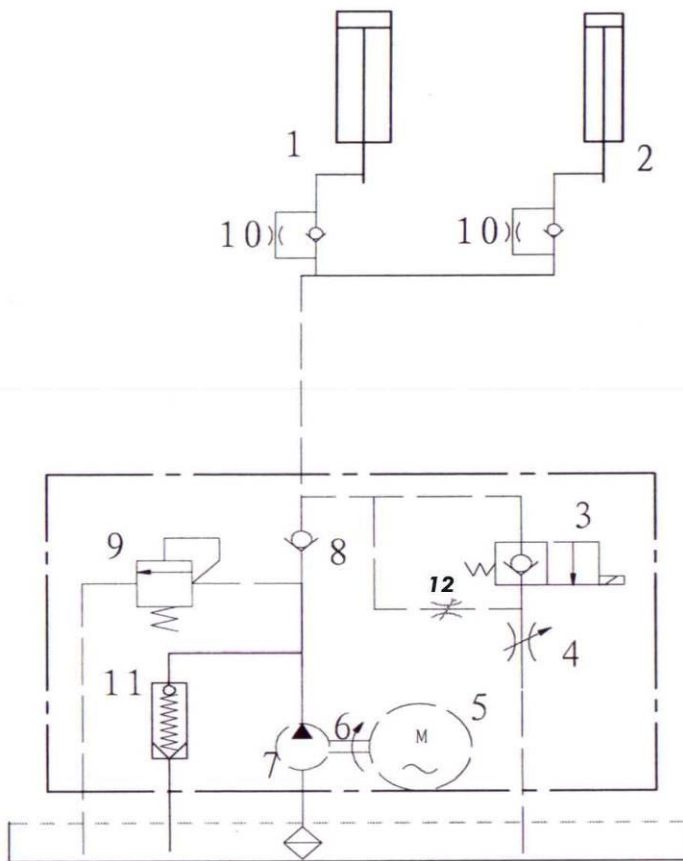

- 1. Main cylinder
- 2. Assistant cylinder
- 3. E-magnetic unloading valve
- 4. Throttle valve
- 5. Motor
- 6. Coupling
- 7. Gear pump
- 8. Single-way valve
- 9. Overflow valve
- 10. Anti-surge valve
- 11. Cushion valve
- 12. Emergent unloading valve

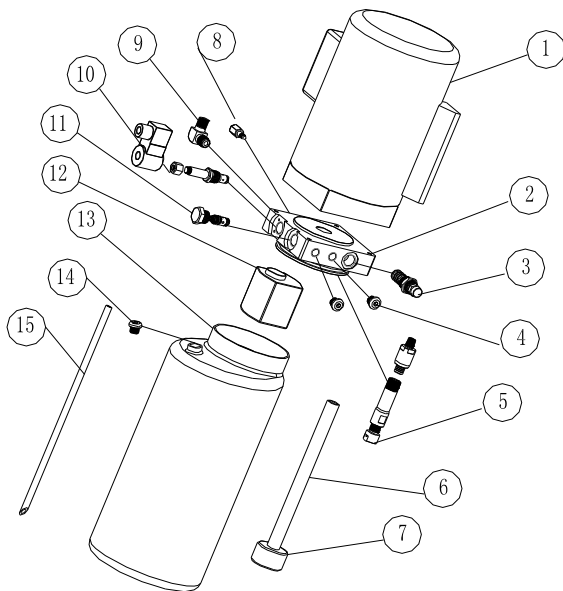

S/N	Name	Qty
1	Motor	1
2	Hydraulic block	1
3	Overflow valve	1
4	Removable plug	2
5	Cushion valve	1
6	Oil absorbing pipe	1
7	Oil filter	1
8	Throttle valve	1
9	Oil pipe tie-in	1
10	E-magnetic unloading valve	1
11	One-way valve	1
12	Gear pump	1
13	Plastic oil tank	1
14	Oil tank cover	1
15	Oil back pipe	1

Annex5, Wiring diagram

Single phase

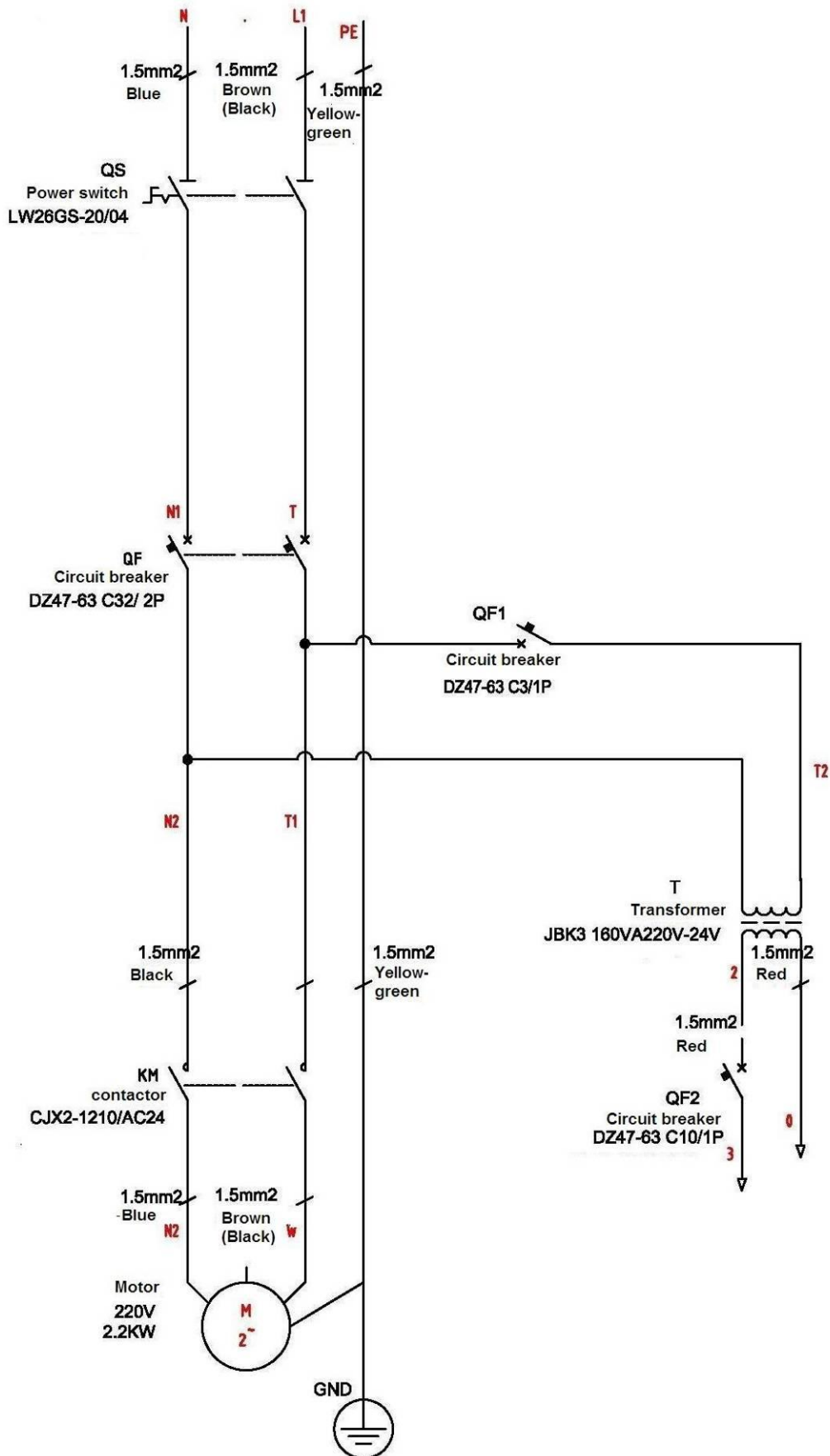

Three phase

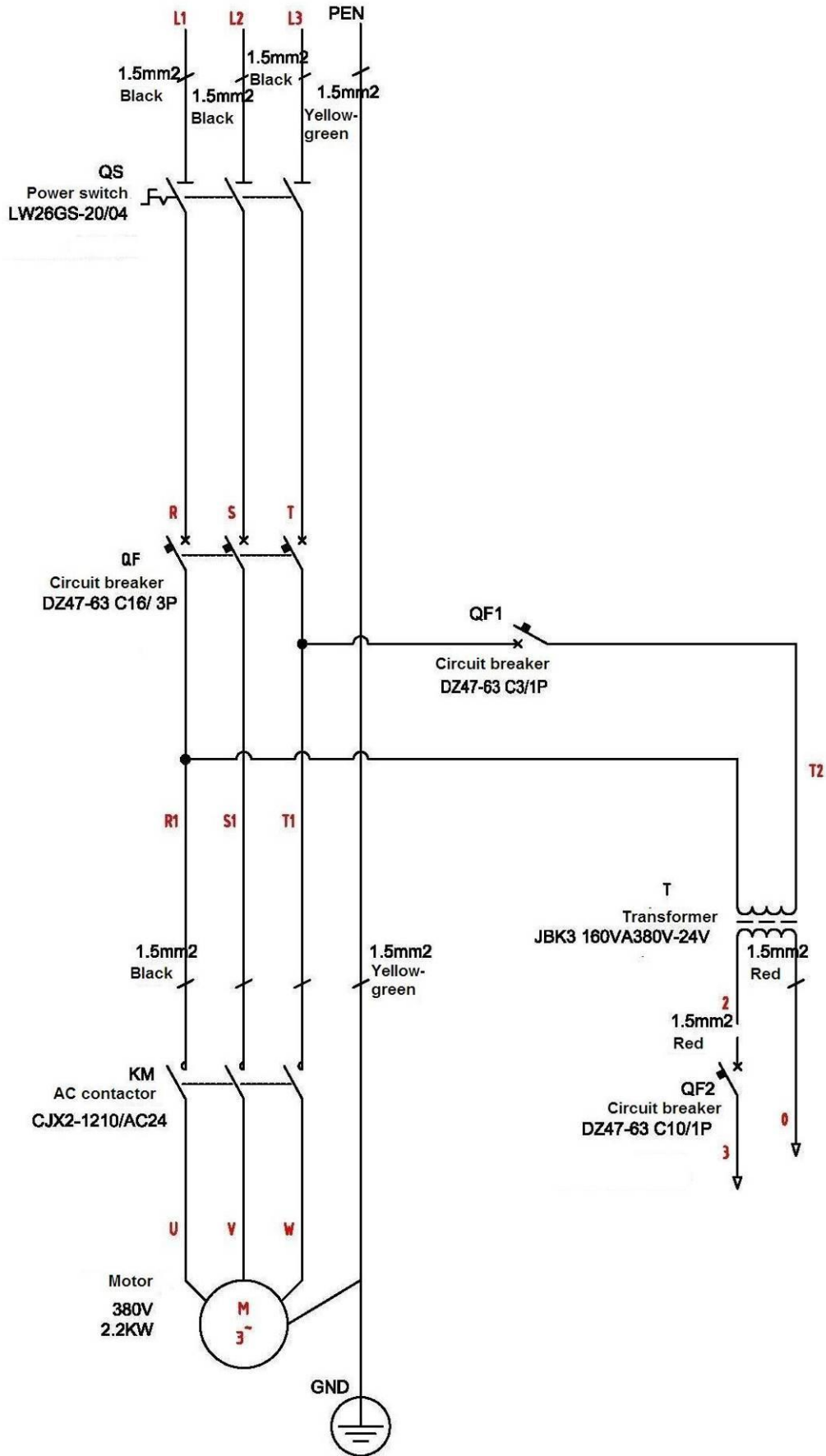

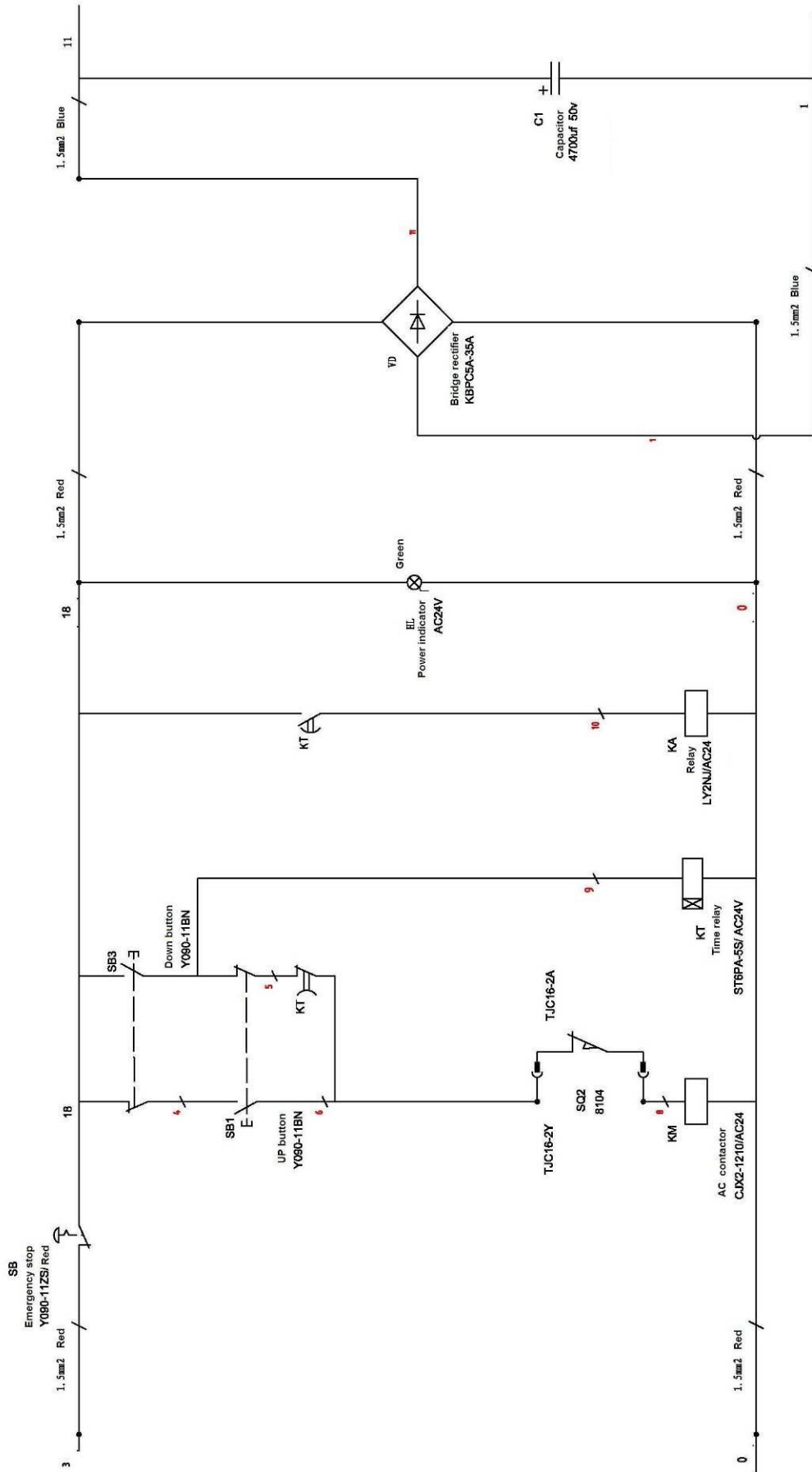

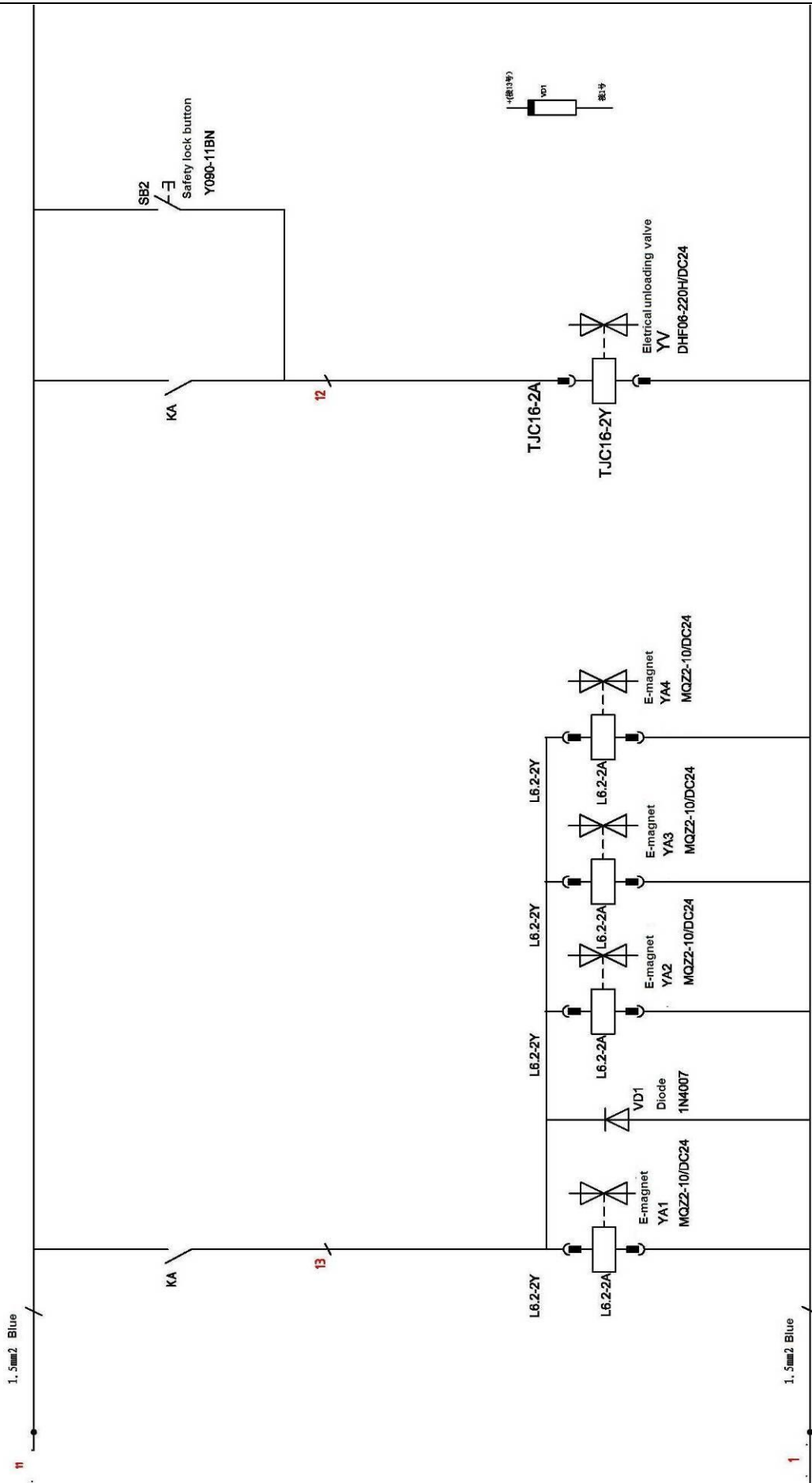

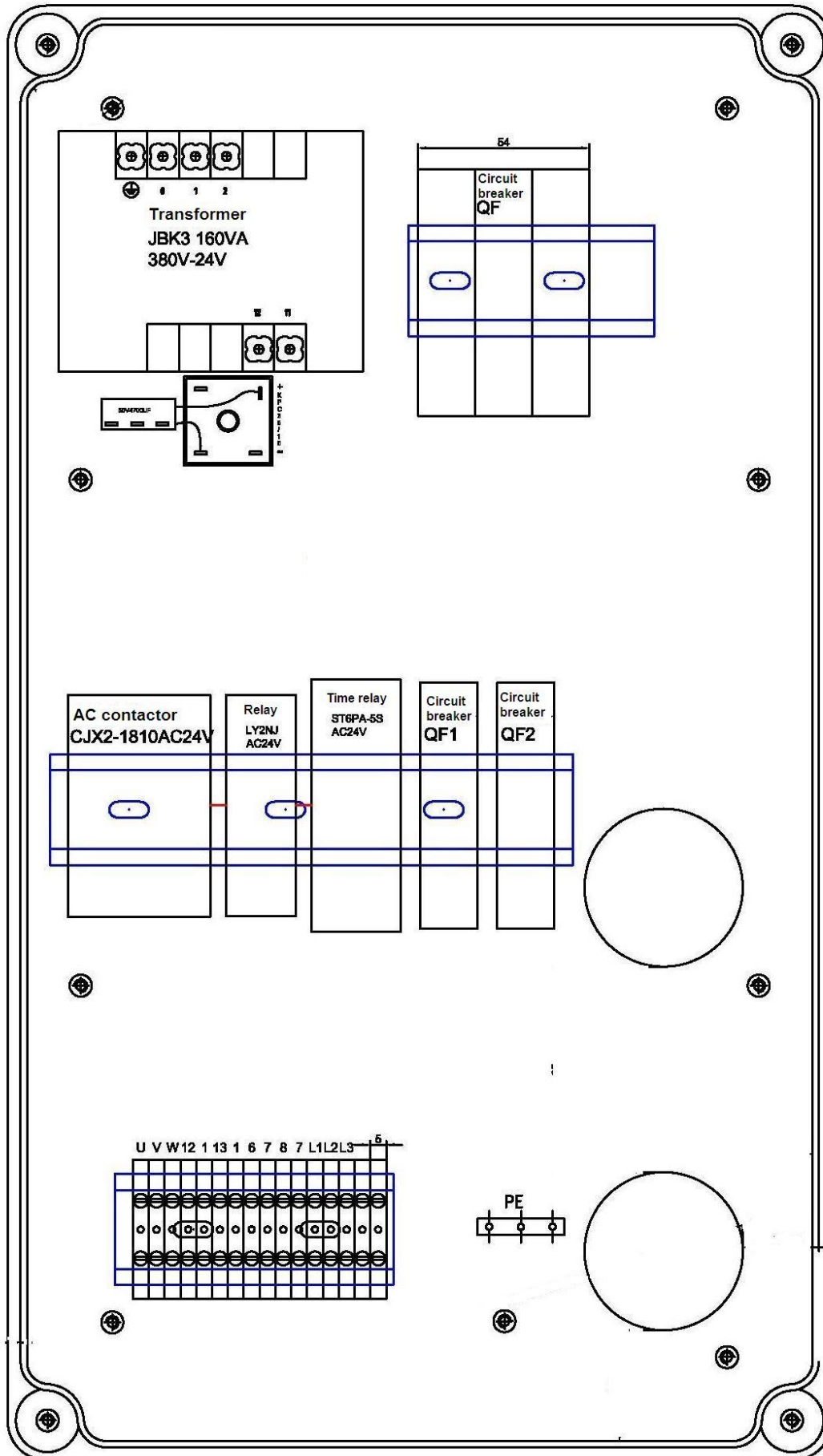

Annex 6, Separated drawings for the lift

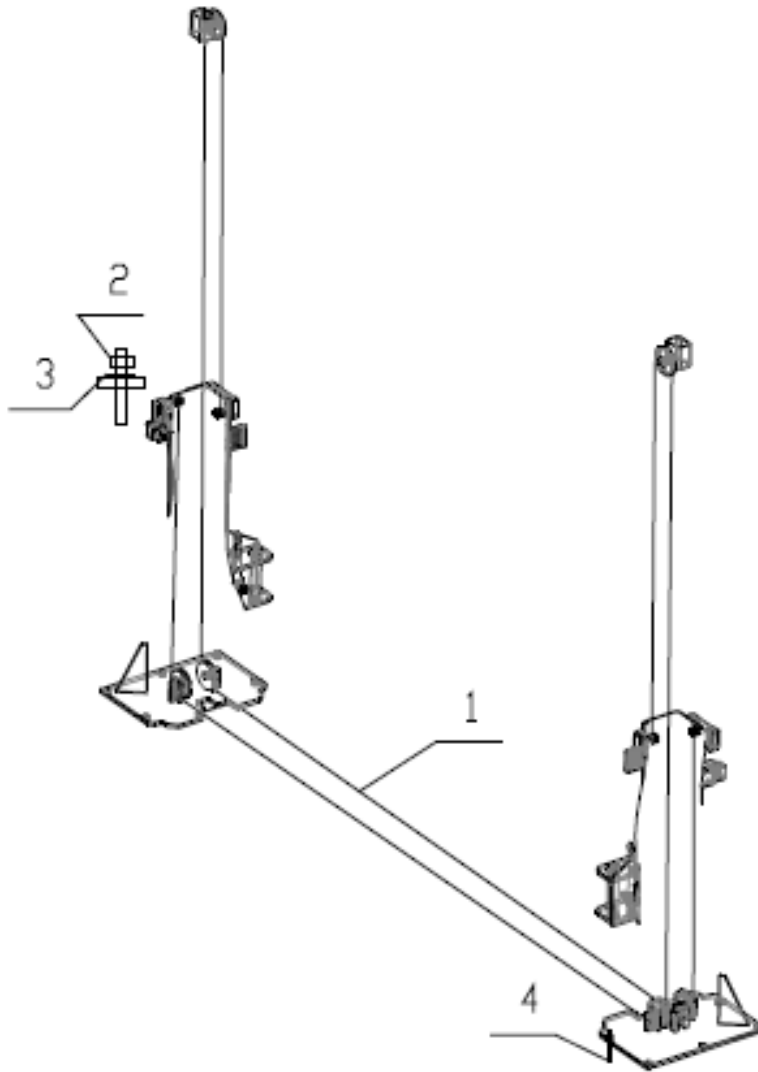

S/N	Material #	Name	Drawing#	Qty	Property	Note
1		Steel cable L=9330mm	FL-8225E-A6	2	Assembly	
2		Hex nut M20	GB/T6170-2000	4	Standard	
3		Class C flat washer M20	GB/T95-1985	8	Standard	
4		Expansion bolt M18*180		12	Standard	

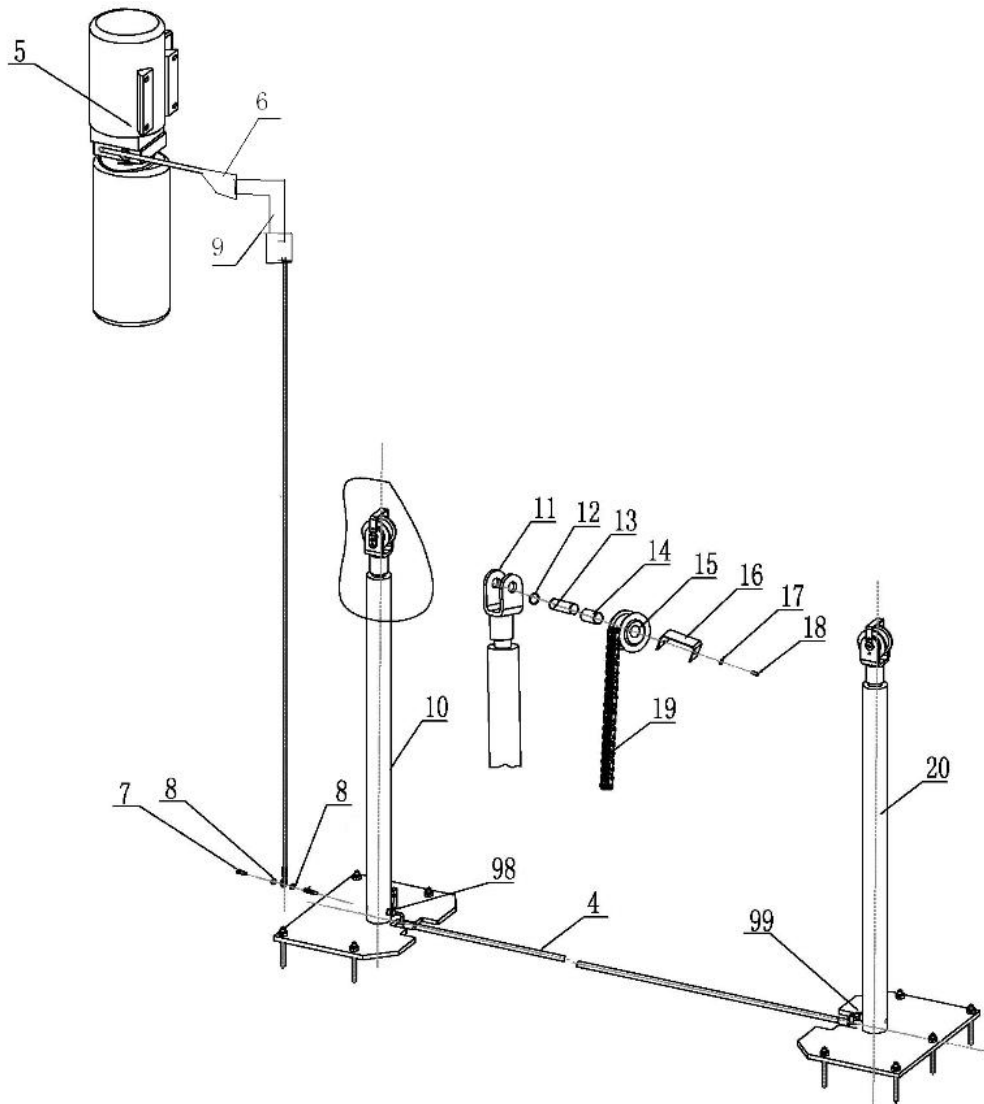

S/N	Material #	Name	Drawing#	Qty	Property	Note
4		Rubber oil hose L=3380		1	Assembly	
5		Power unit (electrical release)		1	Assembly	
6		PU oil hose L=500		1	Assembly	
7		Composite connector		2	Assembly	
8		Composite washer	Match with 1/4connector	4	Standard	
9		Square Connector		1	Assembly	
10		Drive oil cylinder	FL-8225E-A4-B2	1	Assembly	
11		Chain wheel bracket	FL-8224-A4-B9	2	Zinc -plating	
12		Type B circlip 25	GB/T894.2-1986	4	Standard	
13		Chain wheel shaft	FL-8224-A4-B11	2	Zinc -plating	
14		Bearing 2548	SF-1	2	Standard	
15		Chain wheel	FL-8224-A4-B10	2	Zinc -plating	
16		Baffle plate	FL-8224-A4-B12	2	Zinc -plating	
17		Spring washer M6	GB/T93-1987	4	Standard	
18		Inside hex cylinder head screw M6*10	GB/T70.1-2000	4	Standard	
19		Chain	LH1234-127LGB/6074-1995	2	Standard	
20		Assistant oil cylinder	FL-8225E-A4-B3	1	Assembly	
98		Main oil cylinder connector	FL-8224-A4-B4	1	Zinc -plating	
99		Assistant oil cylinder connector	FL-8224-A4-B5	1	Zinc -plating	

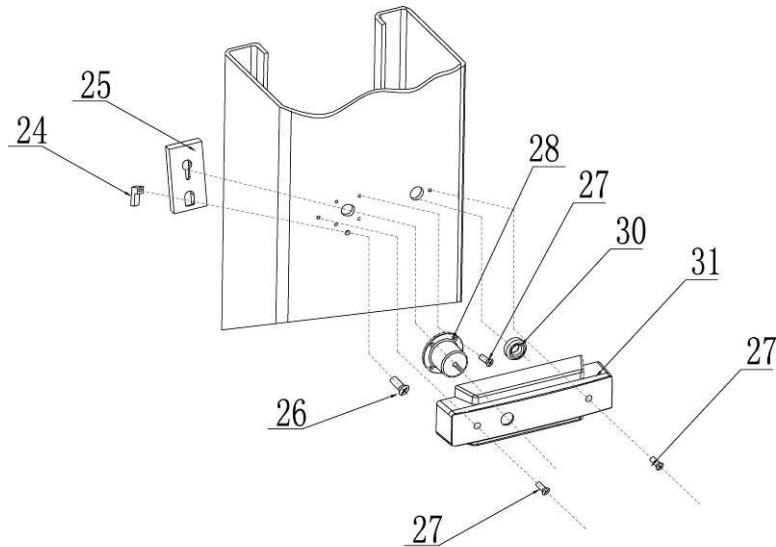

S/N	Material #	Name	Drawing#	Qty	Property	Note
24		Orientation block	FL-8224E-A1-B3	4	Zinc-plating	
25		Safety locking plate	FL-8224E-A1-B2	4	Zinc-plating	
26		Cross cap screw M6*16	GB/T818-2000	4	Standard	
27		Cross cap screw M5*10	GB/T818-2000	24	Standard	
28		Electromagnet	FL-8224E-A1-B4	4	Assembly	
30		φ20 hose protection ring	FL-8224-A1-B6	2	Rubber	
31		Electro-magnet protection cover	FL-8224E-A1-B5	4	Plastic	

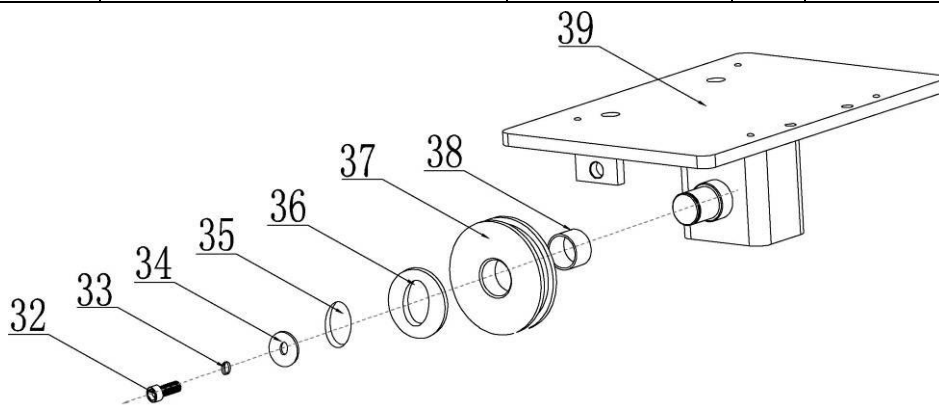

S/N	Material #	Name	Drawing#	Qty	Property	Note
32		Inside hex cap screw M8*16	GB/T70.2-2000	2	Standard	
33		Spring washer M8	GB/T93-1987	2	Standard	
34		Retaining ring	FL-8224-A1-B3-C2	2	Zinc-plating	
35		Type B circlip 25	GB/T894.2-1986	2	Standard	
36		Washer 25		4	Zinc-plating	
37		UP pulley	FL-8225E-A1-B2	2	Zinc-plating	
38		Bearing 2518	SF-1	2	Standard	
39		Top plate	FL-8225E-A1-B3-C1	2	Welded	

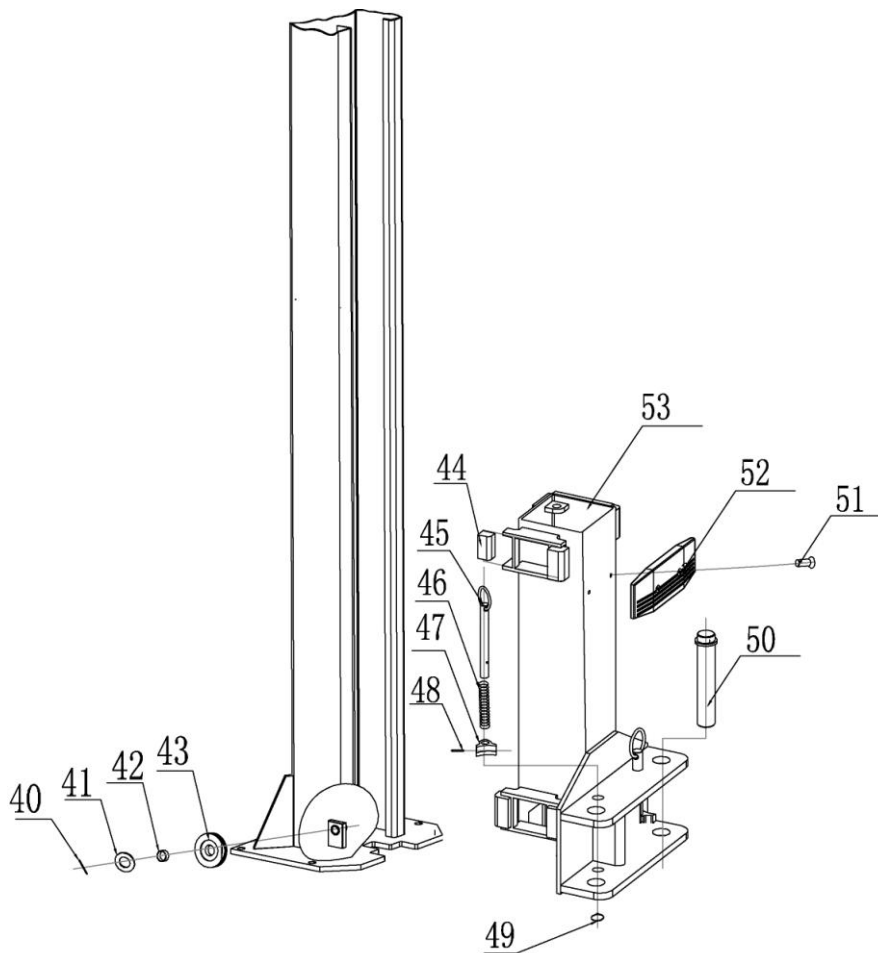

S/N	Material #	Name	Drawing#	Qty	Property	Note
40		Cotter pin $\Phi 2.5 \times 30$	GB/T91-2000	4	Standard	
41		Washer 25		4	Zinc-plating	
42		Bearing 2518	SF-1	4	Standard	
43		Pulley	FL-8225E-A1-B2	4	Zinc-plating	
44		Slider	FL-8224-A3-B6	16	Nylon	
45		Pulling rod	FL-8225E-A3-B4	4	Zinc-plating	
46		Pressure spring	FL-8224-A3-B5	4	Zinc-plating	
47		Teeth block	FL-8224-A3-B4	4	Zinc-plating	
48		Spring pin 5*35	GB/T879.1-2000	4	Standard	
49		Type B circlip 22	GB/T894.2-1986	4	Standard	
50		Shaft	FL-8224-A12	4	Zinc-plating	
51		Cross sunken head screw M8*16	GB/T819.1-2000	4	Standard	
52		Rubber pad	FL-8225E-A3-B2	2	Rubber	
53		Carriage	FL-8225E-A3-B1	2	Welded	

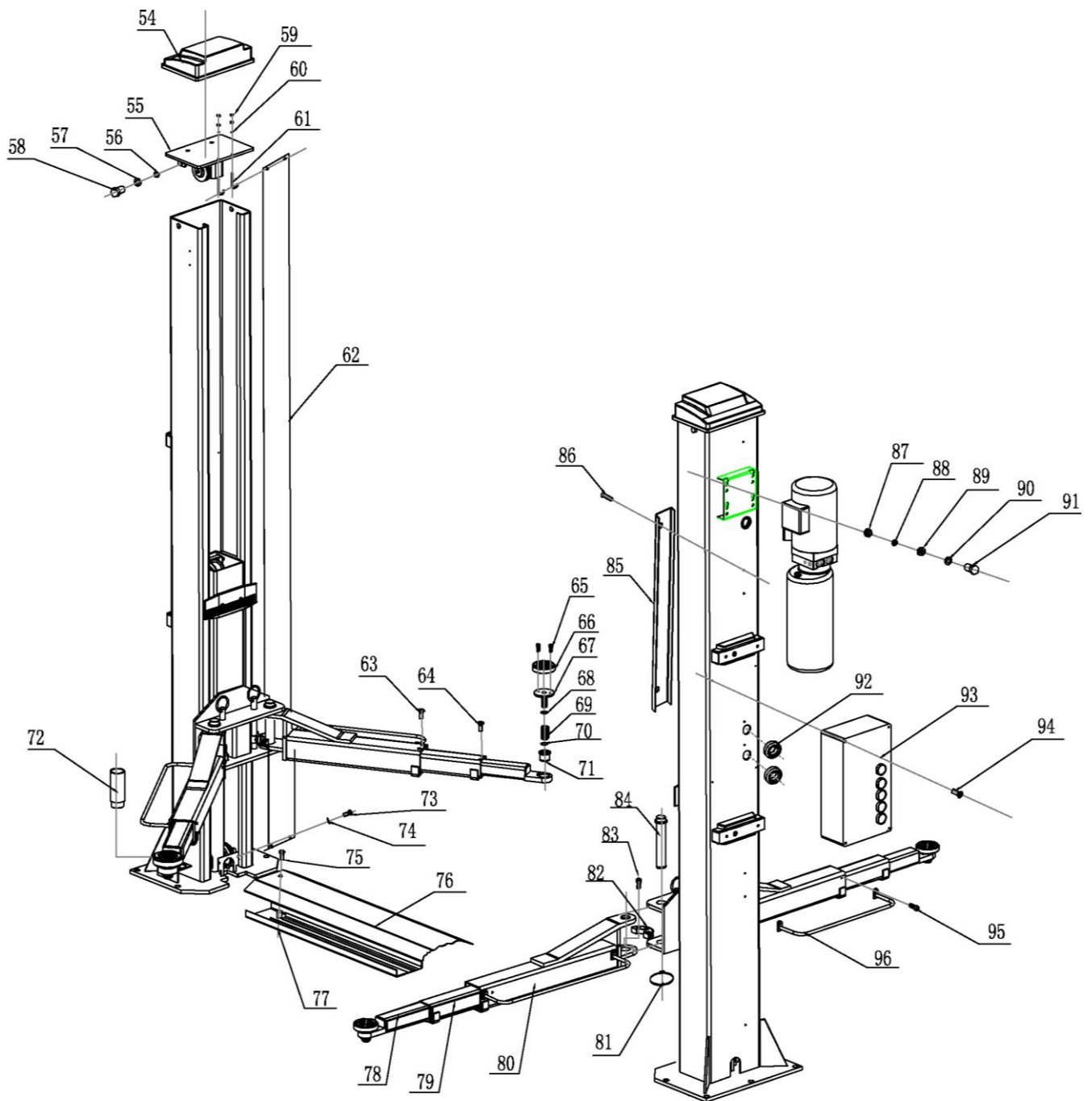

S/N	Material #	Name	Drawing#	Qty	Property	Note
54		Top cap	FL-8225E-A1-B4	2	Plastic	
55		Top plate	FL-8225E-A1-B3	2	Assembly	
56		Class C flat washer M12	GB/T95-1985	6	Standard	
57		Spring washer M12	GB/T93-1987	6	Standard	
58		Hex head full swivel bolt M12*20	GB/T5781-2000	6	Standard	
59		Hex nut M6	GB/T6170-2000	8	Standard	
60		Class C flat washer M6	GB/T95-1985	4	Standard	
61		Rod for protection cloth	FL-8224-A13	4	Standard	
62		Protection cloth	FL-8225E-A10	2	Cloth	

S/N	Material #	Name	Drawing#	Qty	Property	Note
63		Cross sunken head screw M8*12	GB/T819.1-2000	4	Standard	
65		Inside hex sunken head screw M8*20	GB/T70.3-2000	8	Standard	
66		Rubber lifting pad	FL-8225E-A7-B4-C4	4	Rubber	
67		Lifting tray	FL-8225E-A7-B4-C1	4	Welded	
68		Circlip 35	GB/T895.2-1986	4	Standard	
69		Swivel sheath	FL-8225E-A7-B4-C2	4	Zinc-plating	
70		Circlip 42*2.5	GB/T895.2-1986	8	Standard	
71		Inside swivel sheath	FL-8225E-A7-B4-C3	4	Zinc-plating	
72		Height adapter	FL-8225E-A11	4	Zinc-plating	
73		Cross cap screw M6*8	GB/T818-2000	4	Standard	
74		Class C flat washer M6	GB/T95-1985	4	Standard	
75		Inside hex sunken head screw M12*16	GB/T70.3-2000	2	Standard	
76		Base cover plate	FL-8225E-A9	1	Q235A	
77		Slot base plate	FL-8225E-A8	1	Welded	
78		Short arm	FL-8225E-A7-B3	4	Welded	
79		Mid arm	FL-8225E-A7-B2	4	Welded	
80		Lifting arm assembly	FL-8225E-A7-B1	4	Welded	
81		Type B circlip 38	GB/T894.2-1986	4	Standard	
82		Semi-teeth block	6254E-A7-B6	4	Q235A	
83		Inside hex cylinder head screw M10*20	GB/T70.1-2000	12	Standard	
84		Shaft	FL-8225E-A12	4	Zinc-plating	
85		Hose protection cover	FL-8224E-A1-B8	6	Q235A	
86		Cross cap screw M5*25	GB/T818-2000	12	Standard	
87		Hex nut M10	GB/T6170-2000	4	Standard	
88		Spring washer M10	GB/T93-1987	4	Standard	
89		Anti-short pad	FL-8224-A14	4	Rubber	
90		Class C flat washer M10	GB/T95-1985	4	Standard	
91		Hex head full swivel bolt M10*35	GB/T5781-2000	4	Standard	
92		Ø40 hose protection ring	FL-8224E-A1-B7	2	Rubber	
93		Control box	FL-8225E	1	Assembly	
94		Cross cap screw M5*10	GB/T818-2000	4	Standard	
95		Inside hex cap screw M8*12	GB/T70.2-2000	8	Standard	
96		Feet protection fender	FL-8224-A8-B3-C1	4	Welded	

Annex 7. Spare parts list

Spare parts list---electrical system

S/N	Material #	Name	Spec.	Unit	Qty	Pic.
1		Power switch	LW26GS-20/04	Pcs	1	
2		Button	Y090-11BN	Pcs	1	
3		Power indicator	AD17-22G-AC24	Pcs	1	
4		Transformer	JBK-160VA380V-2 4V JBK-160VA220V-2 4V	Pcs	1	
5		AC contactor	CJX2-1210/AC24	Pcs	1	
6		Circuit breaker	DZ47-63 C16/3P DZ47-63 C32/2P	Pcs	1	
7		Circuit breaker	DZ47-63 C3/1P	Pcs	1	
8		Limit switch	TZ8108	Pcs	1	
9		Emergency stop	Y090-11ZS/RED	Pcs	1	
10		Bridge rectifier	KBPC5A-35A	Pcs	1	
11		Capacitor	4700UF/50A	Pcs	1	

S/N	Material #	Name	Spec.	Unit	Qty	Pic.
12		Relay	LY2NJ/AC24	Pcs	1	
13		Relay holder	PTF-08A	Pcs	1	
14		Time relay	ST6PA-5S/AC24V	Pcs	1	
15		Time relay holder	PYF-08AE	Pcs	1	
16		Control box	260*460*135	Pcs	1	

Spare parts list---mechanical part

S/N	Material #	Name	Drawing#	Qty	Property	Note
1		Slider	FL-8224-A3-B6	16	Nylon 1010	
2		Rubber lifting pad	FL-8225E-A7-B4-C4	4	Rubber	
3		O-shape seal ring	Inside diameter 23.6*3.55			
4		Y-shape seal ring	SD70*60*8			
5		Anti-dust ring	DHS40(40*48*5/6.5)			

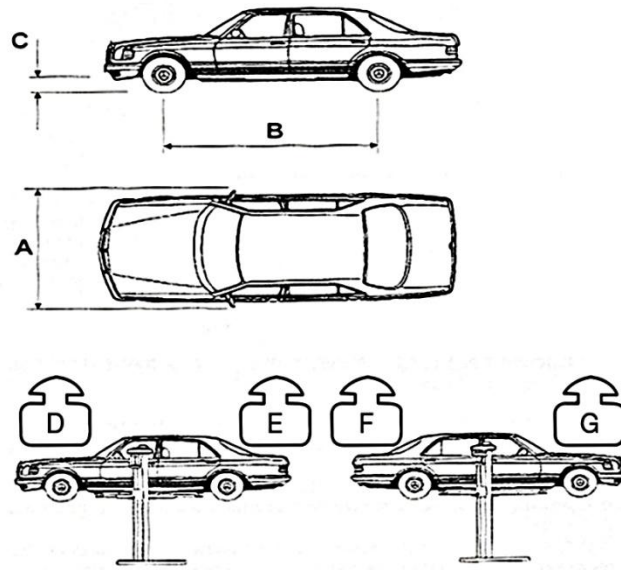

Modell Nr.	A (mm)	B (mm)	C (mm)	D (kg)	E (kg)	F (kg)	G (kg)
TW 250	2720	3850	100	2800	2200	2800	2200



Preperation protocol

The lift type with the
serial number: was built on
by the company in
and was checked for safety and function and was put into operation.

The set up and preparation was carried out by the OPERATOR | EXPORT

The safety of the lift was checked by an .

The operator confirms the installation of the lift, and qualified experts have confirmed proper
install before launching unit.

Date	Owner/ Operator	Signature
------	-----------------	-----------

Date	Installation expert	Signature
------	---------------------	-----------

Address Owner/ Operator:
.....

Address Installation expert:
.....



Inspection findings

Regular/ extraordinary inspection

On the date of this lift was put through a regular/ extraordinary and thorough inspection. During this inspection these issues were/ were not found.

.....

Scope of the audit:

Outstanding partial inspection:

The use of this equipment is authorized and the machine and all features have been inspected .

Location/ Date	Inspectors signature
----------------	----------------------

Operator or agent

Taken notes of the defects
----------------------------	-------	-------

Defect corrected
	Date	Signature

Verification

	Date	Signature
--	------	-----------

On the date of this lift was put through re-inspection. During this inspection these issues were/ were not found.

The use of this equipment is authorized and the machine and all features have been inspected.

Location/ Date	Inspectors signature
----------------	----------------------

Safety review pursuant to UVV type

Safety inspection before commissioning/ regular checks/ extraordinary

(Mark off those that do not apply)

Inspection	Good shape	defective	Re-inspection	Notes
Warning labels/ signs				
Name plate/ ID				
Limit switch function				
Condition of rubber plates				
Function of carrier arm locks				
Supporting structure (cracks etc.)				
Function of safety latches				
All screws tight				
Condition of steel cables				
Condition of covers				
Condition of chain				
Condition of cable pulleys				
Condition of hydraulic lines				
Fluid level of hydraulic unit				
Hydraulic system seals				
Condition of the piston rod				
Condition of electronics				
Function test of the lift				
Foundation condition (cracks)				
Lift Slides/guides in the lift column				
Other				
(Check the appropriate box, if re-inspection is necessary mark that box as well!)				

Inspector (Name, Address):

Inspected on:

Inspection result:

- Commissioning/ use possible. Resolve issues by
- Commissioning/ use prohibited. Re-inspection necessary.
- No defects. Commissioning/ use possible.

Signature owner/ operator:

Signature inspector:

Inspection findings

Regular/ extraordinary inspection

On the date of this lift was put through a regular/ extraordinary and thorough inspection. During this inspection these issues were/ were not found.

.....

Scope of the audit:

.....

Outstanding partial inspection:

.....

The use of this equipment is authorized and the machine and all features have been inspected .

Location/ Date	Inspectors signature
----------------	----------------------

Operator or agent

Taken notes of the defects
----------------------------	-------	-------

Defect corrected
	Date	Signature

Verification

	Date	Signature
--	------	-----------

On the date of this lift was put through re-inspection. During this inspection these issues were/ were not found.

The use of this equipment is authorized and the machine and all features have been inspected.

Location/ Date	Inspectors signature
----------------	----------------------

Safety review pursuant to UVV type

Safety inspection before commissioning/ regular checks/ extraordinary
 (Mark off those that do not apply)

Inspection	Good shape	defective	Re-inspection	Notes
Warning labels/ signs				
Name plate/ ID				
Limit switch function				
Condition of rubber plates				
Function of carrier arm locks				
Supporting structure (cracks etc.)				
Function of safety latches				
All screws tight				
Condition of steel cables				
Condition of covers				
Condition of chain				
Condition of cable pulleys				
Condition of hydraulic lines				
Fluid level of hydraulic unit				
Hydraulic system seals				
Condition of the piston rod				
Condition of electronics				
Function test of the lift				
Foundation condition (cracks)				
Lift Slides/guides in the lift column				
Other				
(Check the appropriate box, if re-inspection is necessary mark that box as well!)				

Inspector (Name, Address):

Inspected on:

Inspection result:

- Commissioning/ use possible. Resolve issues by
- Commissioning/ use prohibited. Re-inspection necessary.
- No defects. Commissioning/ use possible.

Signature owner/ operator:

Signature inspector:



The company

Twin Busch GmbH | Amperestr. 1 | D-64625 Bensheim

declares hereby, that the **2-post vehicle lift**

TW 250 + TW 250 B4.5 | 5000 kg

serial no.

in the configuration placed on the market by us, meets the relevant safety and health requirements, as required by the following EC directive(s) in it's/their current version(s).

EC-directive(s)

2006/42/EC Machinery

2006/95/EC Low Voltage

Applied harmonized standards and regulations

EN 1493:2010 Car lifts

EN 60204-1:2006/A1:2009 Safety of machinery - Electrical equipment of machines

CE Certificate

N8M 15 04 87411 014

date of issue: 20.04.2015

M6A 15 04 87411 013

place of issue: München

technical file no.: 646821 400902

Certification body

TÜV Süd Product Service GmbH,

Ridlerstraße 65,

D-80339 München

Notified Body Appointment No. 0123

Any alteration to the equipment, improper use or installation void this declaration.

Authorized person to compile technical documentation is: Michael Glade (adress as below)



TWIN BUSCH GmbH

Amperestr. 1 · 64625 Bensheim

Tel. 06251 / 70585-0 · Fax: 70585-29

Authorized signatory: Michael Glade

Bensheim, 23.06.15 Qualitätsmanagement

Twin Busch GmbH | Amperestr. 1 | D-64625 Bensheim

twinbusch.de | E-Mail: info@twinbusch.de | Tel.: +49 (0)6251-70585-0



Twin Busch GmbH | Amperestraße 1 | D-64625 Bensheim
Tel.: +49 (0) 6251-70585-0 | Fax: +49 (0) 6251-70585-29 | info@twinbusch.de