



TW 236 PE

Premium-Line Lift
Electronic

twinbusch.de



INSTALLATION, OPERATION AND MAINTENANCE MANUAL



Read this entire manual carefully before installation or operation of the lift.
Follow the instructions strictly.

Twin Busch GmbH | Amperestraße 1 | D-64625 Bensheim
Tel.: +49 (0) 6251-70585-0 | Fax: +49 (0) 6251-70585-29 | info@twinbusch.de



TWIN BUSCH GmbH

INDEX

1. Important warnings	3 - 5
1.1 Warnings	
1.2 Qualified personnel	
1.3 Safety warnings	
1.4 Warnings	
1.5 Noise level	
1.6 Training	
2. General overview	5-5
2.1 General description	
2.2 Technical Data	
2.3 Construction plan	
3. Installation instructions	6-11
3.1 Before Installing	
3.1.1 Equipment	
3.1.2 Check list	
3.1.3 Ground requirements	
3.2 Before Installation	
3.3 Installation	
3.4 Check list after installation	
4. User instructions	11-13
4.1 Safety precautions	
4.2 Control box	
4.3 Assembly instructions	
4.4 Instructions	
4.5 Emergency lowering (Power cut)	
5. Trouble shooting	14
6. Maintenance	15
7. Attachment	16-29
Attachment 1: Pack list	
Attachment 2: Dimensions	
Attachment 3: Floor mounting Instructions	
Attachment 4: Hydraulic system	
Attachment 5: Circuit diagram	
Attachment 6: Lift Diagrams	
Attachment 7: Spare parts, adapter for transporters	
Attachment, Size and weight requirement for vehicles	
Attachment, CE-Certificate and EG-declaration of conformity	

1. Safety warnings



1.1 Important notice

The manufacturer will take no responsibility for improper installation, improper usage, overloading or non suitable ground for mounting the lift.

This model is specially designed for lifting vehicles up to the specified weight. Usage for other purposes will not be covered by the manufacture or the dealer for accidents or damage. (Weight distribution see diagram page 31)

Pay careful attention to the approved weights! The warning stickers on the lift show the specifications. Never attempt to lift vehicles above the specified weight!

Always read the manual carefully to avoid damage or accidents through misuse.

(Weight, wheel base and vehicle sizes, see Diagram page 43)

1.2 Qualified personnel

1.2.1 Only qualified and trained staff should be allowed to operate the lift.

1.2.2 The electrical connections should be carried out by an electrician.

1.2.3 People or customers are not allowed in the lift and working area.

1.3 Safety warning

1.3.1 Never mount the lift on asphalt or other soft surfaces.

1.3.2 Read the safety warnings thoroughly before using the lift.

1.3.3 Never leave the control panel when the lift is in motion

1.3.4 Always keep hands and feet away from moving parts especially when lowering the lift.

1.3.5 Only qualified trained personnel are allowed to operate the lift.

1.3.6 Always wear suitable clothing

1.3.7 The lift and surrounding area should be kept clean to avoid accidents

1.3.8 The lift is designed to lift complete vehicles which do not exceed the lifting capacity. (See page 31).

1.3.9 **Make sure that all safety locks are engaged before any attempt is made to work under or near the lift.** Never remove any safety related components from the lift and do not use if such parts are damaged or missing.

1.3.10 Do not rock the vehicle or cause excessive weight displacement by removal of heavy parts when working on the lift.

1.3.11 All moving parts of the lift should be regularly maintained and checked. Should any parts be damaged, work on the lift should be stopped immediately and you should contact the service partner for advice.

1.3.12 When not in use the lift should be lowered completely to the floor and the electric turned off.

1.3.13 If the lift is not used for a longer period of time, it is recommended to:

- a. Disconnect the power source.
- b. Empty the oil tank.
- c. Lubricate the moving parts with grease.

1.4 Warning signs

All safety warning labels are clearly depicted on the lift to ensure that the operator is aware of dangers during operation.

Warning labels should be kept clean and replaced when damaged or missing.

<p>ATTENTION!</p> <p>Please read the instruction manual and safety warnings before using!</p>	<p>ATTENTION!</p> <p>Use of the lift by qualified personnel only!</p>	<p>ATTENTION!</p> <p>Use only the vehicle manufacturer's recommended lifting points!</p>	<p>ATTENTION!</p> <p>Check vehicle for security shortly after lifting!</p>
<p>ATTENTION!</p> <p>Repairs and maintenance only by qualified personnel, do not tamper with lift safety devices!</p>	<p>ATTENTION!</p> <p>Only qualified personnel are allowed within the lift working area!</p>	<p>ATTENTION!</p> <p>Never exceed the recommended lifting capacity!</p>	<p>ATTENTION!</p> <p>Attention when removing heavy vehicle parts!</p>
<p>ATTENTION!</p> <p>Always keep escape routes free!</p>	<p>ATTENTION!</p> <p>No persons under the lift (when lifting or lowering)!</p>	<p>ATTENTION!</p> <p>Never try to lift using only one side of the lift!</p>	<p>ATTENTION!</p> <p>Protect the lift against damp, especially the electrical connections!</p>
<p>ATTENTION!</p> <p>Always take care of your feet when lowering!</p>	<p>ATTENTION!</p> <p>Never climb on the lift!</p>	<p>ATTENTION!</p> <p>Avoid excessive shaking of the vehicle!</p>	<p>ATTENTION!</p> <p>Danger of shock!</p>

1.5 Noise level

The Noise level of the lift should not exceed 75 decibel.

1.6 Training

Only qualified trained people are allowed to operate the lift. Professional training is offered when necessary.

2. Overview of the lift

2.1 General description

The lift consists of two posts, lifting arms, electric motor and hydraulic cylinders.

The hydraulic pressure is built up in the pump and controlled through the electromagnetic valve.

The cylinder pushes against the slide on which the lifting arms are fixed.

As the arms are being lifted the safety mechanism drops into the latches to prevent the lift from falling due to a failure in the hydraulic system.

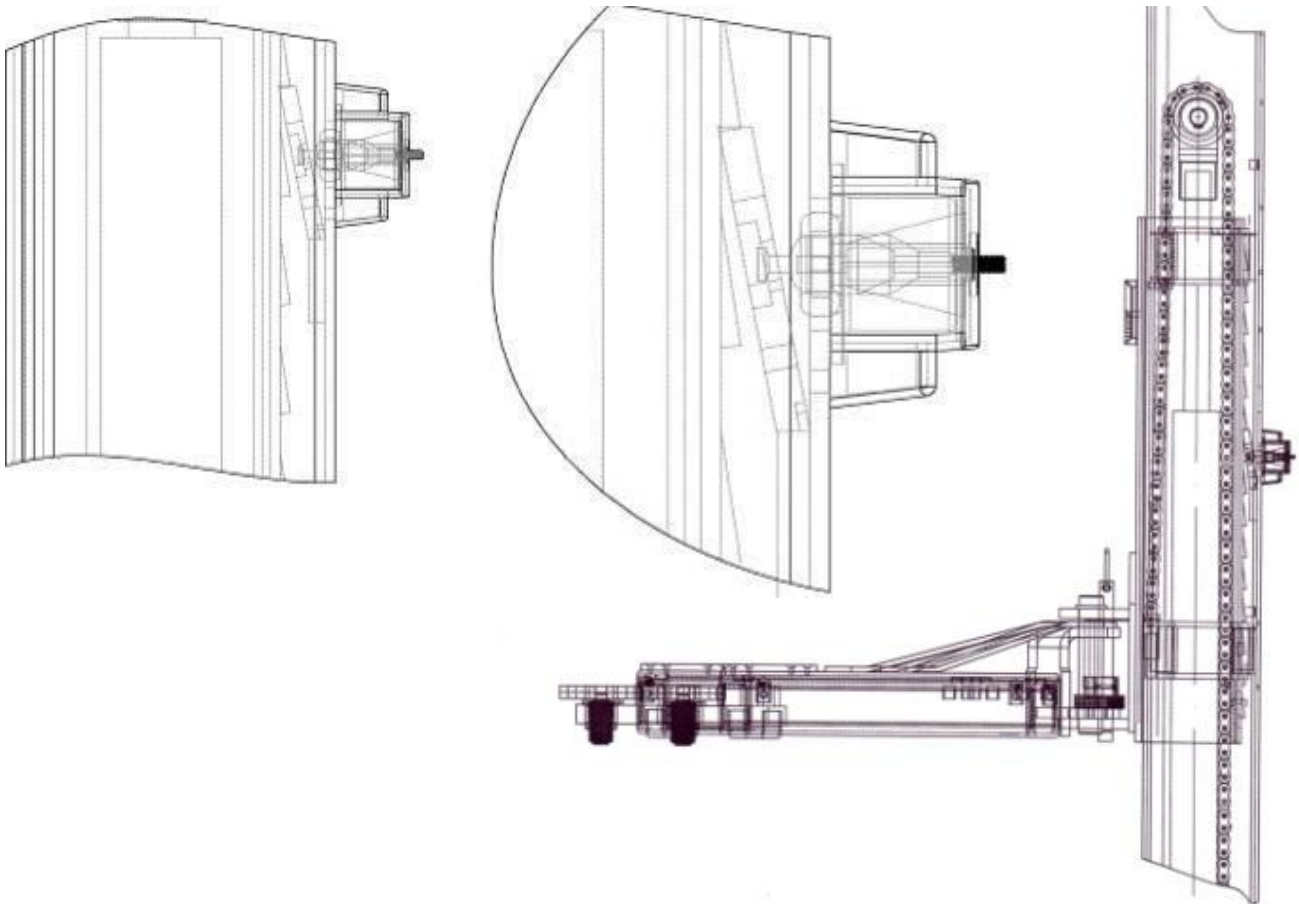

2.2 Technical data

Model	Lifting capacity	Lifting time	Lifting height	Height	Width	Width between posts
TW236 PE	3600kg	50 Sec	1930 mm	2824 mm	3437mm	2880 mm

2.3 Construction of the lift

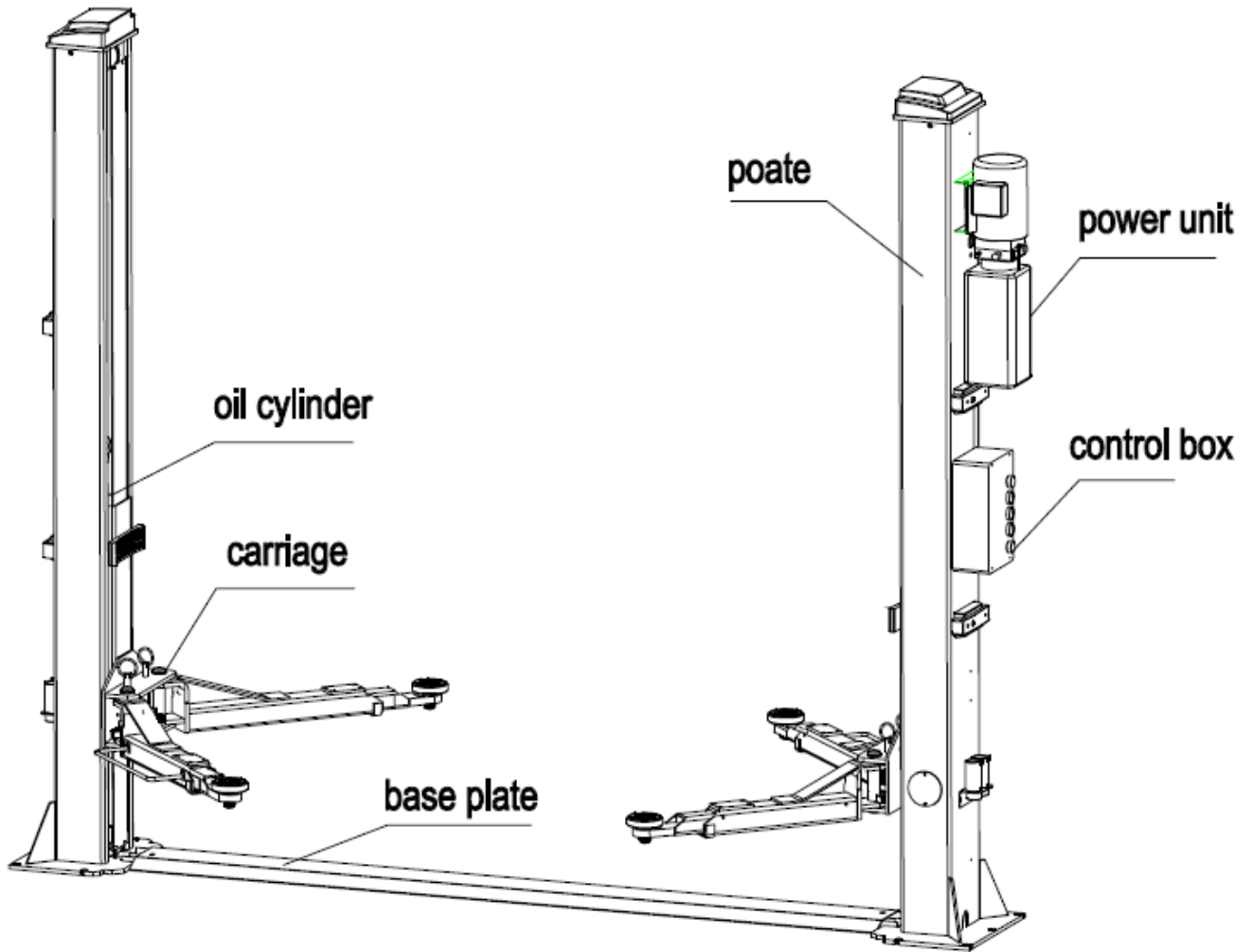

3. Installation

3.1 Before Installation

3.1.1 Needed tools and equipment

- ✓ Appropriate lifting equipment
- ✓ Hydraulic oil HLP 32
- ✓ Hammer drill
- ✓ Set of spanners (17, 19, 22) sockets, screw drivers and Allen keys
- ✓ Hammer, pliers

3.1.2 Check list - Attachment 1 (Pack list)

Unpack all parts and check that nothing is missing or damaged using the attachment 1 as a reference.

Should anything be missing or damaged do not hesitate to contact us, should any parts be missing or damaged and the lift is assembled, we will take no responsibility for damage or injury.

3.1.3 Ground condition

The lift should be mounted on a smooth flat surface with a hardness of approximately 3000 psi, with a tolerance of 5mm and a thickness of at least 200mm. If new concrete is laid, 28 days should be allowed for hardening.

Safety precautions before Installation

3.2.1 Check that the posts are parallel and are vertical to the floor.

3.2.2 All hydraulic, pneumatic and electrical connections should be checked for leakage and tightness before the lift is used.

3.2.3 All screws and bolts should be checked for tightness.

3.2.4 Do not use a vehicle on the lift for the first trial.



3.3 Installation

Step 1: Remove from the packing and prepare the spare parts and covers needed.

(This step is very important and the information in the diagram should be read and understood before operating).

Step 2: With the aid of a forklift remove the supports between the two posts, and then remove the frame screws

Attention: Please take care that the posts cannot fall or slip as this could cause injury or damage.

Step 3: After removing the first post place a support under the other post and then remove the screws.

Step 4: Fit the post extensions and then mount the cross beam. (Make sure all bolts are tightened)

Step 5: Erect the posts, main post first and then the assistant post.

1. Drill anchor holes for each plug bolts on the ground with an electrical drill. Make sure to drill vertically.
2. After holes have been drilled, remove thoroughly the debris and dust in them and ascertain that the posts stay upon the circle previously drew by chalk.

- Step 6:**
1. Drill the holes for the floor anchors making sure that the holes are vertical.
 2. Remove all dust and particles and place the anchors in the holes, use a hammer to drive in the bolts.
 3. Tighten to recommended torque.

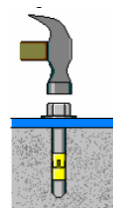
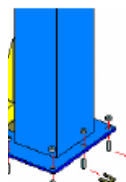
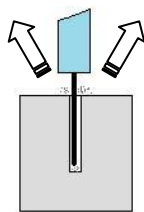
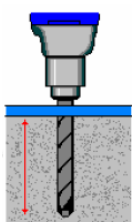

Step 7: Mount the safety mechanism and the electro magnets then the protection cover.

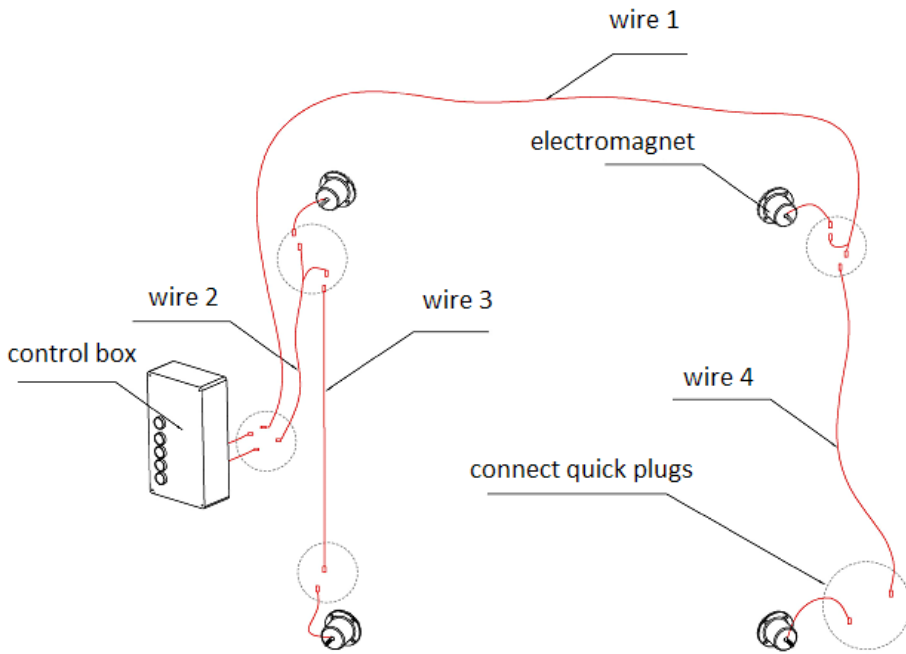
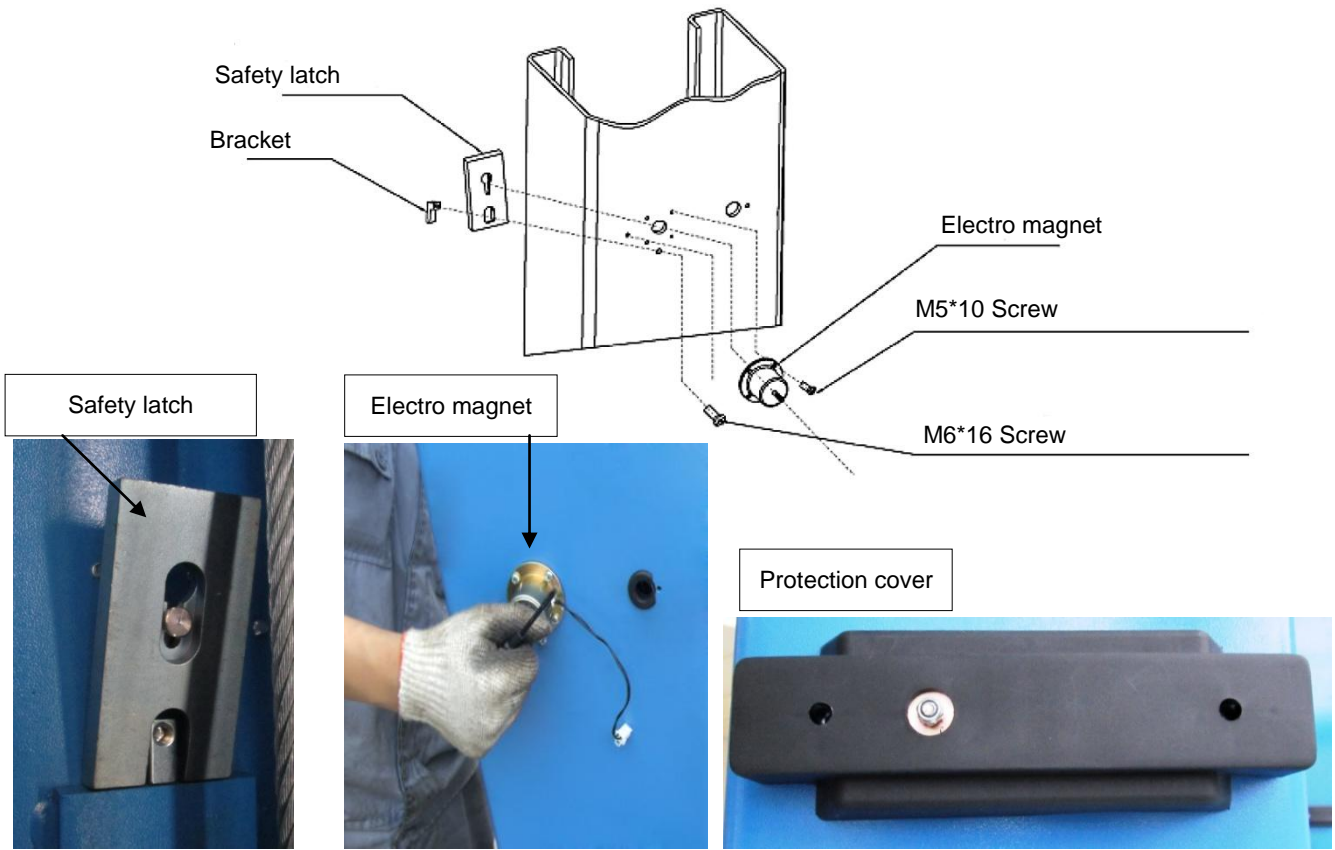

Mount the Limit switch on the upper inner side of the main post.



Step 7 : Fitting the bottom protection plate.

Raise the lift to about 800mm and activate the safety locks, then mount the base plate

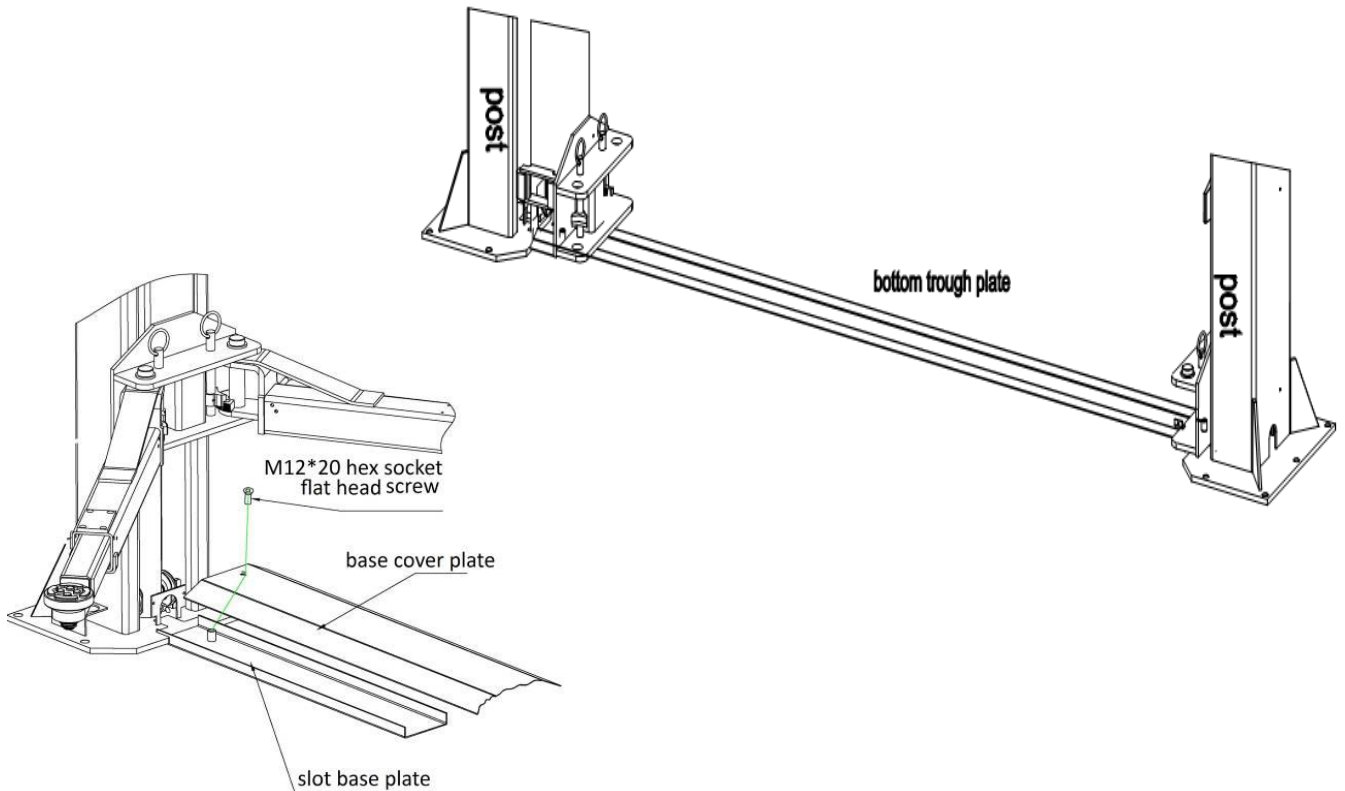

Step8: Connecting the steel cables.

1. Raise carriages on both sides approximately 800mm above the ground.
2. Make sure that the safety locks on each column are fully engaged before attempting to route the cables.
3. Carriages must have the same height from the floor before proceeding.
4. Fit the cables as shown in the diagram.
5. The cables should be so adjusted that the safety mechanism engages simultaneously when lifting.
6. The cables must be secured and lubricated.

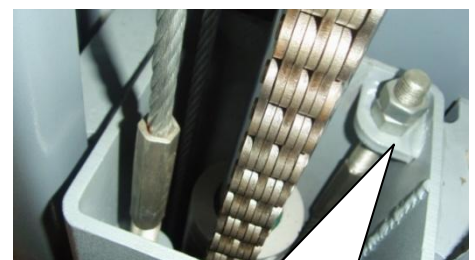
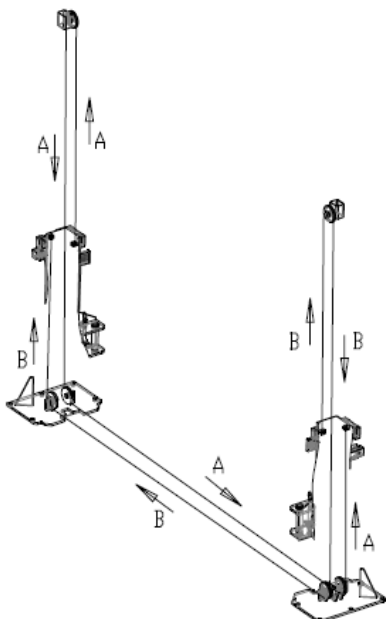

Cable adjustment nut, **make sure both nuts are tightened!**

Step9: Connect the oil hose.

Connect the oil hose as in the following diagram.

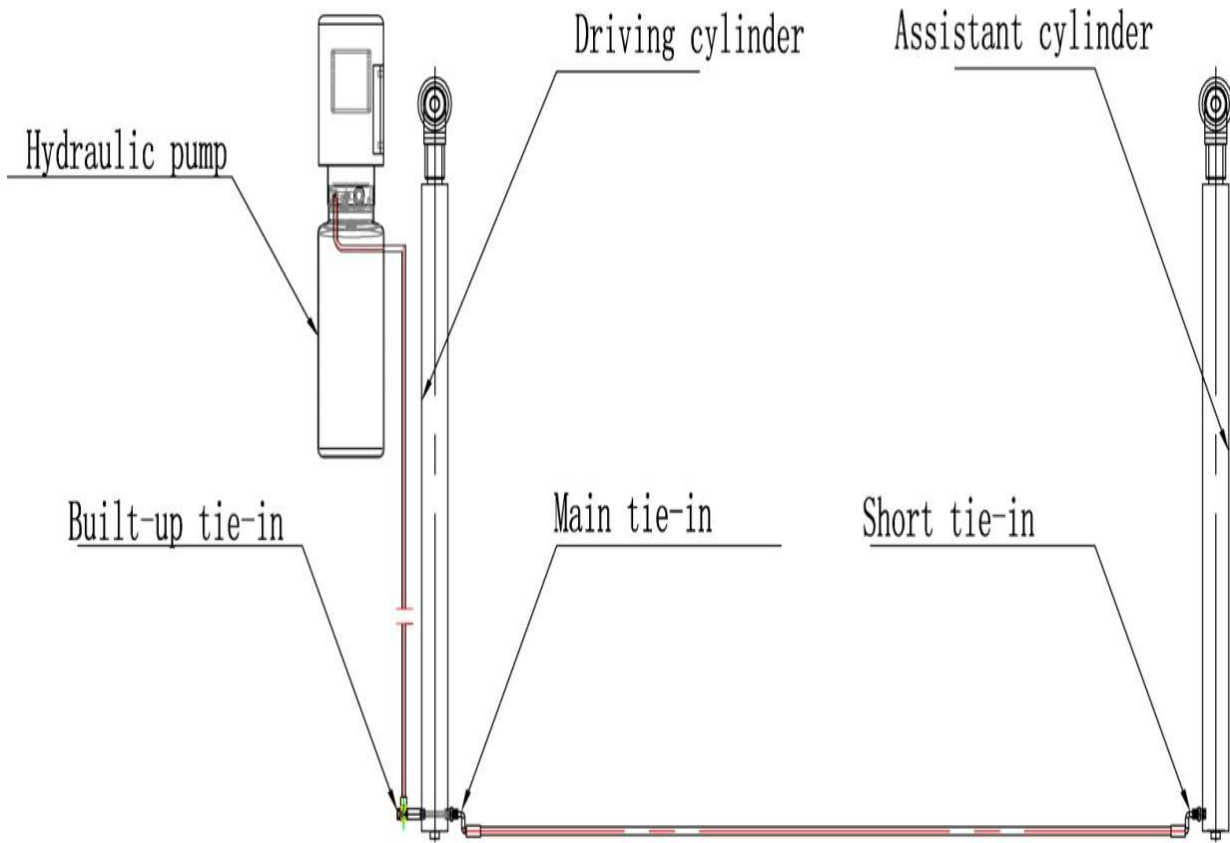

Step10: Mounting the Pump and the control box.

1. Mount the power unit onto the main post.
2. Connect the pump with the control box as in the wiring diagram.

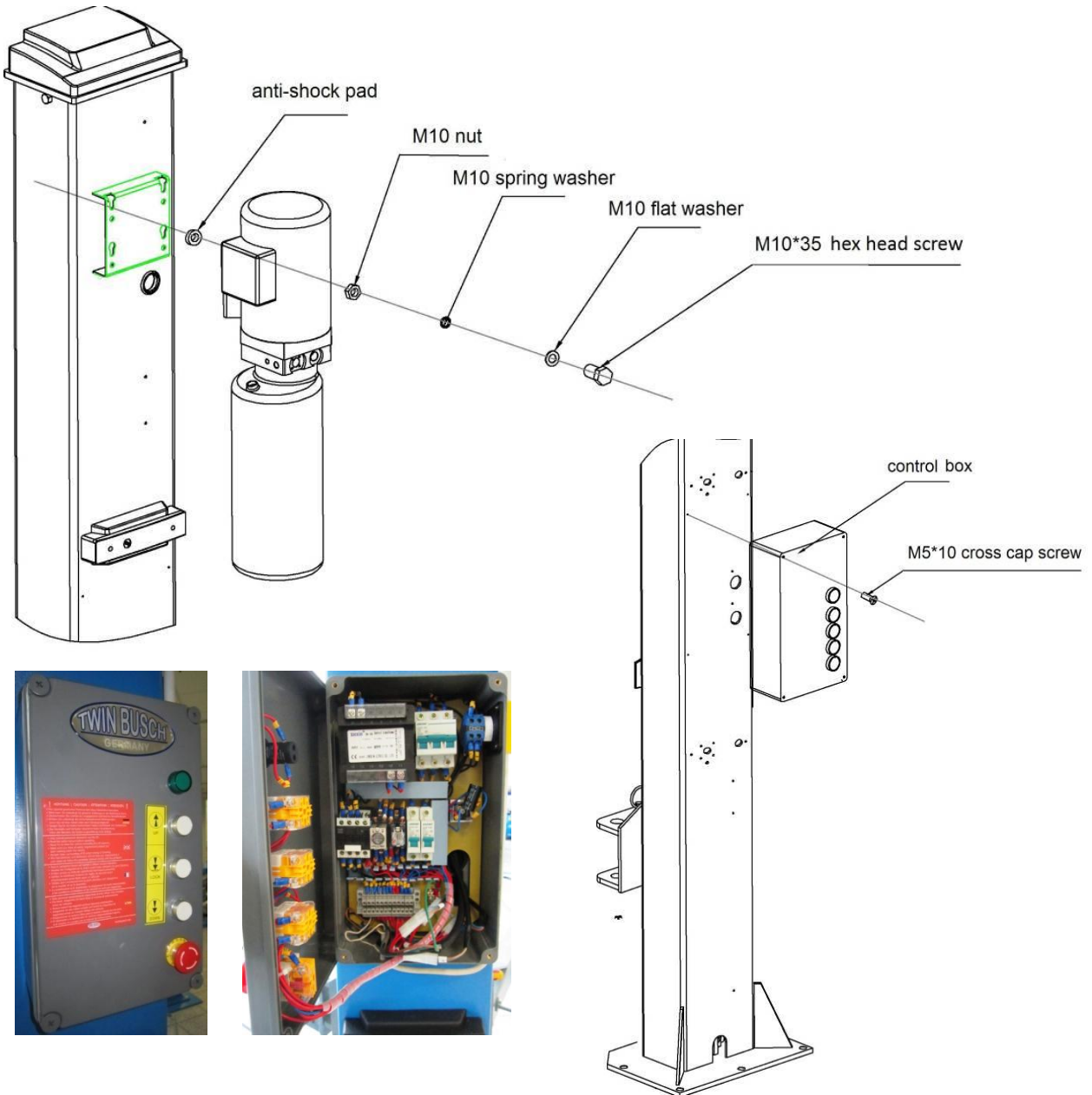

Step 11: Install the oil hose protector.

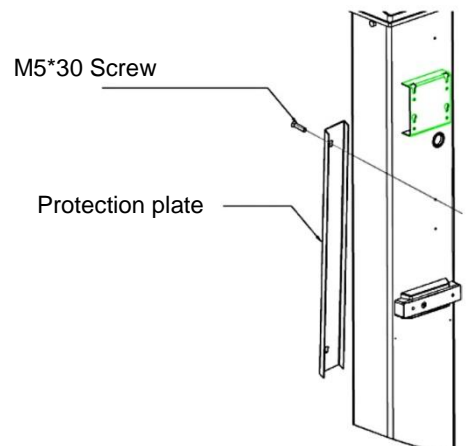

Oil hose protection plate

Step12: Install the lifting arms.

Connect the lifting arm and the carriage with the pins. Install the swing arms on the carriages and make sure the safety lock and half moon are correctly positioned.

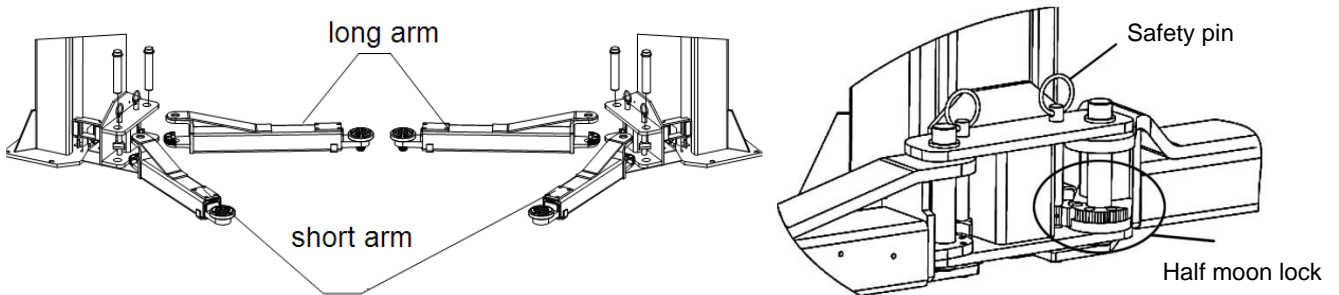

Filling with Hydraulic oil

The oil tank has a volume of 10 Liters and should be filled to at least 80% to ensure the pump has enough oil. (Recommended oil HLP 32).

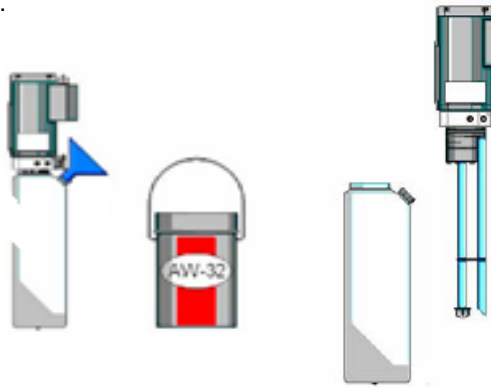

Step 14: Testing

1. When testing the lift for the first time **NEVER** do the test with a vehicle on the lift.
2. Check all the connections.

Step 15: Mount the post covers and the door protections.

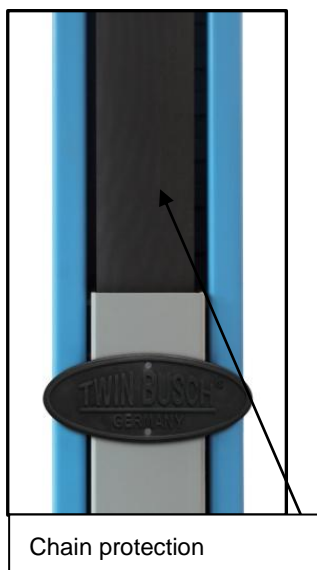

3.4 Check list after installation

S/N	To check	Y	N
1	Are the posts vertical? (90°)		
2	Are both posts parallel to each other?		
3	Are all oil connections correct?		
4	Are the cables secure and tight?		
5	Are the lifting arms correctly mounted?		
6	Are all electrical connections correct?		
7	Are all bolts, screws and joints secure?		
8	Are all moving parts and cables lubricated?		

4. Operation instructions

4.1 Safety checks

- 4.1.1 Check all connections for leaks, if no leaks are found the lifting process can begin.
- 4.1.2 If the safety devices are not working the lift may not be used.
- 4.1.3 When a vehicle is lifted it is very important that the weight is correctly balanced, the manufacture and dealers will take no responsibility for any damage or injury caused by improper use.
- 4.1.4 Operators and other personnel must stand clear of the lift when in use. Personnel must stand in a designated safety area.
- 4.1.5 When the lift has reached the desired height the power should be turned off to avoid tampering.
- 4.1.6 Make sure that all safety locks are engaged before working under the lift.

4.2 Descriptions of control box

Description	Function
Main switch	On/Off
Power indicator	Shows Power supply
UP-Button	To lift
Safety lock	To apply safety lock
DOWN-Button	To lower the lift
Emergency stop butt	Turns off power supply

4.3 Flow chart for operation

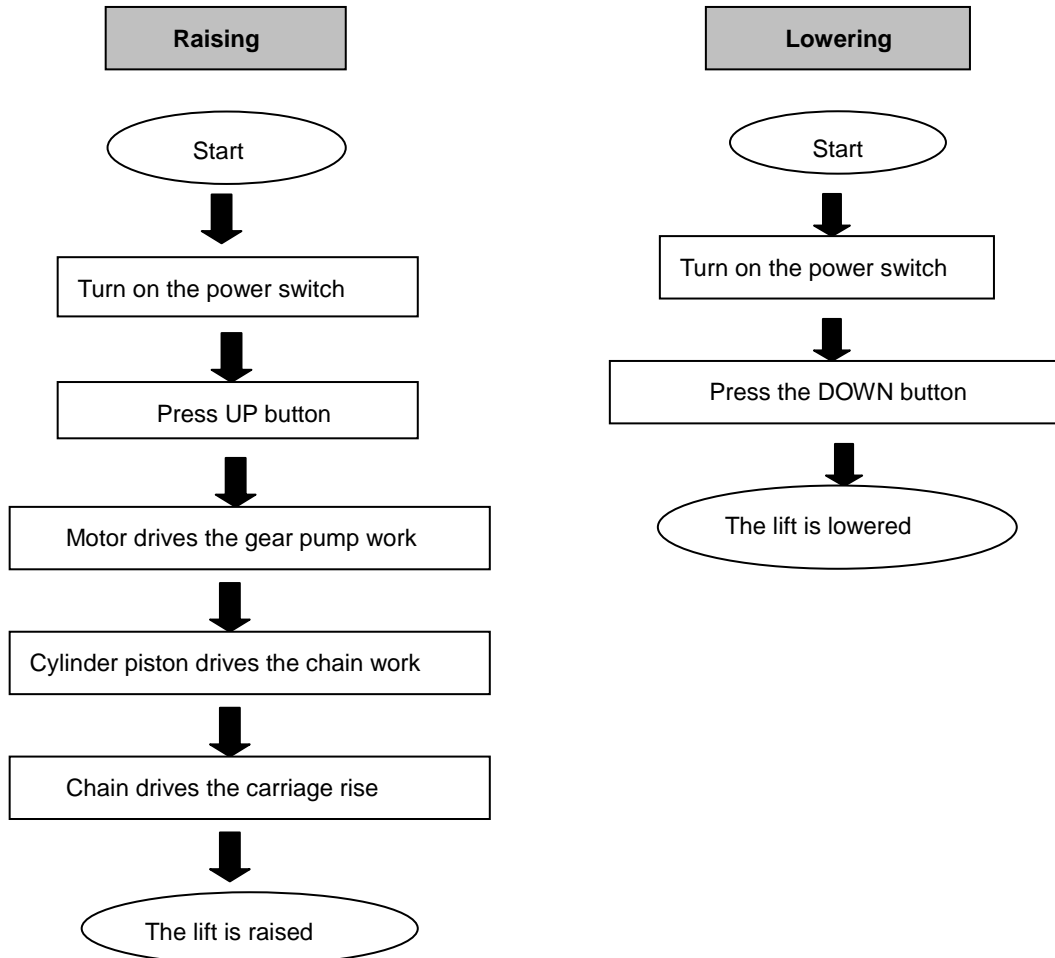

4.4 Operating instructions

Raising the lift

1. **Always read the instruction and safety manuals before working with the lift.**
2. Drive the vehicle onto the centre of the lift making sure the weight is evenly displaced.
3. Make sure that the vehicle can't roll or move from the desired position.
4. Turn on the main switch and press the UP button until the lift has reached the desired height.
5. When the lift has reached the required level press the safety lock button to engage the mechanical safety mechanism.
6. When all safety precautions have been taken, turn off the main switch and check the stability before working on the

Lowering the lift

1. Turn on the power.
2. Press the DOWN (I) button. The lift will automatically rise to disengage the safety mechanism before going down.
The lift will stop at approximately 800mm from the floor.
3. Press the DOWN (II) button to lower the lift, an alarm signal will be heard as the lift descends to the floor.
4. Remove the vehicle.

4.5 Emergency lowering in case of power cut

When the safety mechanism is not engaged:

- a. Release all four Electromagnets, on the posts simultaneously.

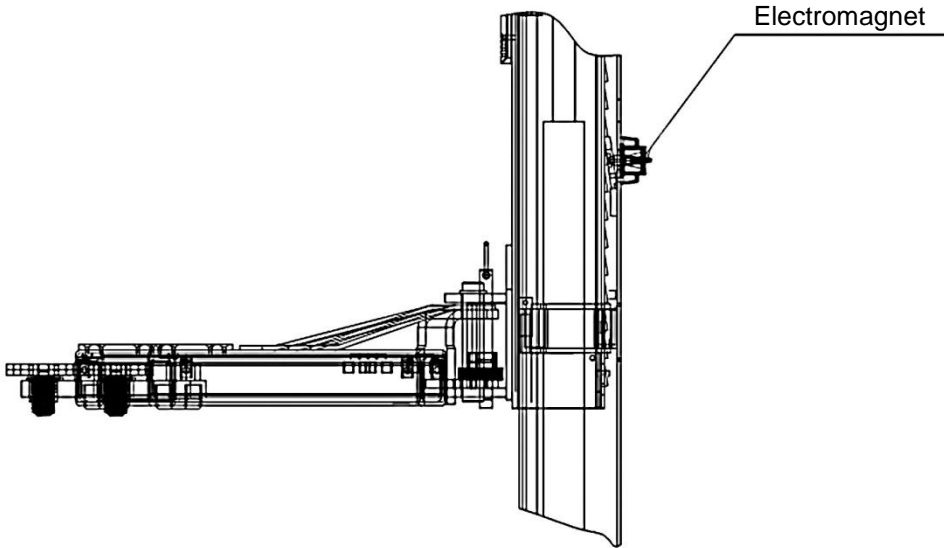

- b. Turn the valve screw manually.

(Press the screw in and turn left to open and right to close. „OPEN“ (↺) „CLOSE“ (↻))

Electromagnetic valve

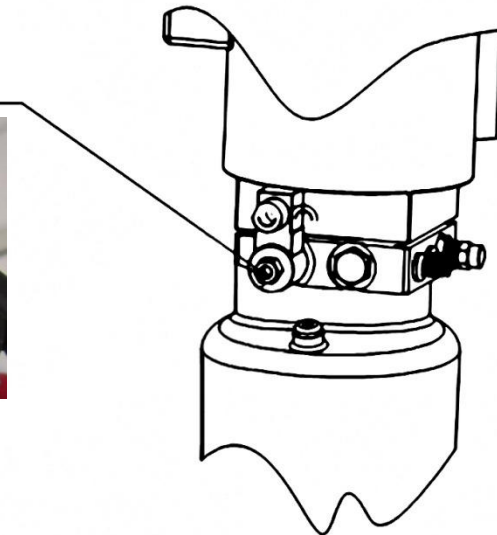
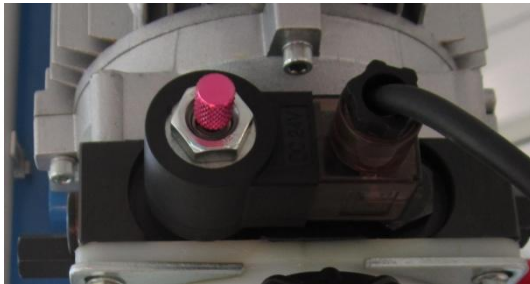

When the safety mechanism is engaged:

- a. Open the hydraulic plug to enable the connection of a manual pump. (if available).

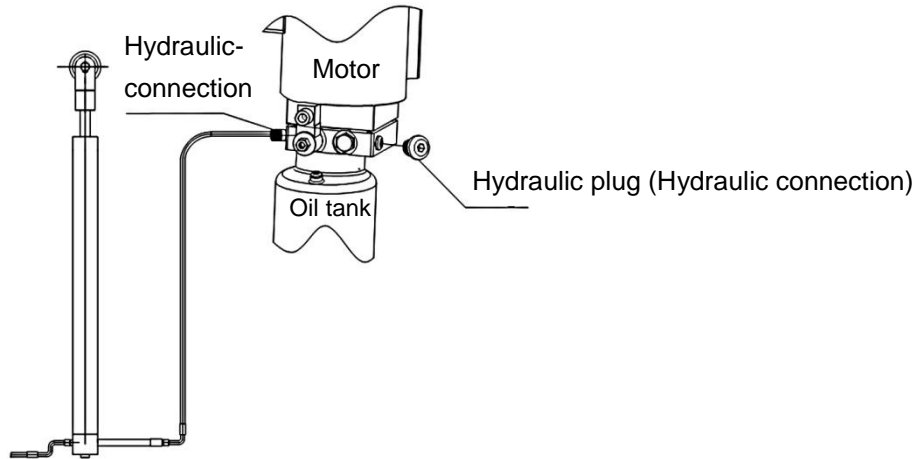

- b. Press the pump lever to fill the cylinder with oil (optional) the safety can now be released.

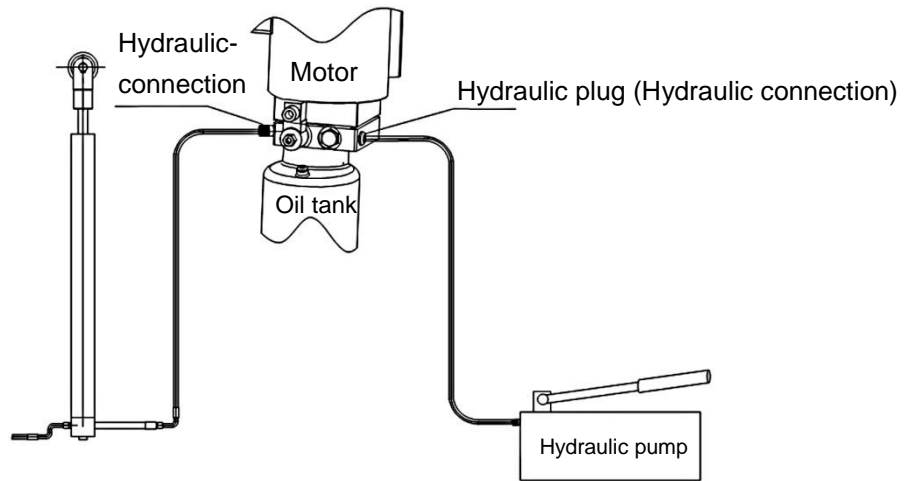

- c. Release all four Electromagnets, on the posts simultaneously and hold.

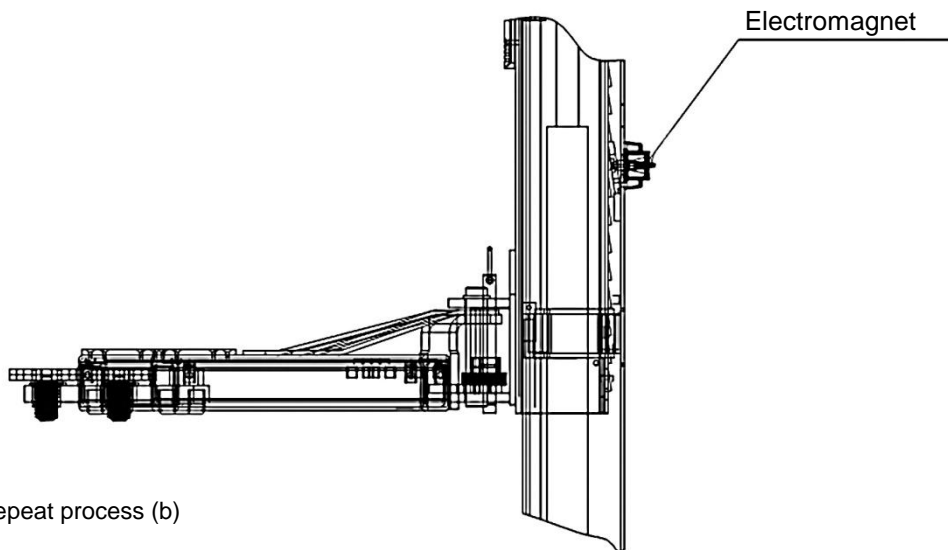

Repeat process (b)

Trouble shooting

Attention: Please don't hesitate to contact us if you can't solve the problem yourself.

We will help as soon as possible. To help us help you please send a detailed description of your problem with pictures if possible. This way we can diagnose your problem much quicker.

PROBLEME	Cause	Solution
Abnormal noise.	Excessive wear on the inside of the post.	Lubricate the inner side (grease).
	Dirt on the post runner.	Clean the runners.
Motor does not run / lift does not rise.	Loose wires	Check wires/ connections
	Motor is defect.	Replace
	The limit switch is defect or loose connector	Reconnect or replace the switch
Motor runs, lift doesn't rise	Motor is running backwards	Check wiring.
	Pressure valve is loose or blocked.	Tighten / Clean.
	Gear pump is defect.	Replace.
	Oil level too low.	Top up Oil.
	Oil hose loose or damaged.	Tighten or replace.
	Cushion valve loose or blocked	Clean / Tighten
Lift lowers too slowly.	Oil hose is leaking	Tighten / Replace.
	Cylinder piston leaking	Replace gasket.
	Direction valve is leaking	Clean /replace.
	Pressure valve is leaking.	Clean / replace.
	Manual or electrical release valve is blocked	Clean / replace.
Lifting to slow	Oil filter blocked or not sealed	Clean / replace.
	Oil level too low.	Top up oil
	Pressure valve wrongly adjusted	Adjust
	Oil is too hot. (over 45°C)	Change oil
	Cylinder gasket.	Replace
Lift is to slow	Restriction valve blocked	Clean / replace.
	Hydraulic oil dirty	Change oil.
	Release valve blocked	Clean
	Oil hose damaged.	Replace
Steel cable is worn	Is not lubricated	Lubricate / Replace

Maintenance

Simple low cost maintenance will enhance the safety and prolong the life of your lift.

The service intervals can be chosen in between working times. Here are the lubrication (greasing points):

S/N	Description
1	Cable pulley (top)
2	Steel cable
3	Chain wheel
4	Chain
5	Slide
6	Bolt
7	Safety lock
8	Lifting arm
9	Lifting plate
10	Cable pulley (bottom)

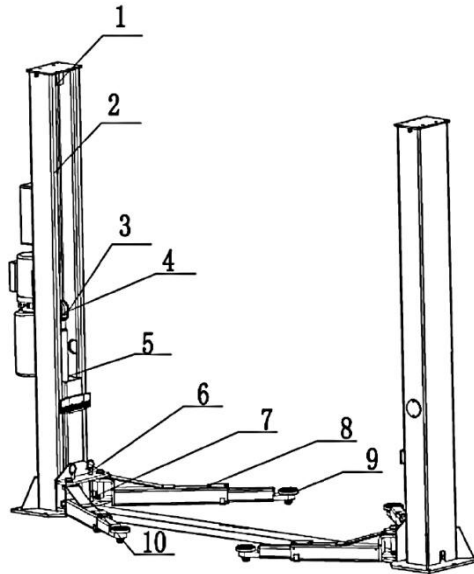

6.1. Daily service before use

It's very important to have a daily safety check before the lift is used. Discovery of worn or defect parts saves time and expensive repairs, and loss through damages or injuries.

- Check oil hoses for leakage and damage.
- Check all electrical connections and make sure they are in good condition.
- Check that all bolts are securely tightened.
- Check that the safety mechanism is working properly and no visible wear can be seen.

6.2. Weekly service

- Check all moving parts.
- Check the movement of safety parts.
- Raise the lift completely to check the oil level, refill if necessary.
- Check that all bolts are securely tightened.

6.3. Monthly service

- Check that all bolts are securely tightened.
- Check that all moving parts have enough lubrication and the whole construction is in good working order.
If damaged parts are discovered they should be replaced

6.4. Yearly service

- Empty and clean the oil tank, replace with new oil
- Replace the oil filter.

When the user follows the above service suggestions the lift will stay in a good working condition and unnecessary costs can be avoided.

Attachment (Pack List)

S/N	Material #	Name	Drawing#	Property	Qty
1		Power side post assembly	FL-8224E-A1	Assembly	1
2		Post assembly	FL-8224E-A2	Assembly	1
3		Carriage assembly	FL-8224E-A3	Assembly	2
4		Power unit		Assembly	1
5		Oil cylinder	FL-8224-A4-B3	Assembly	1
6		Drive oil cylinder	FL-8224-A4-B2	Assembly	1
7		Electrical system		Assembly	1
8			Control box		1
9			Wire package		1
10		Steel cable L=8820mm	FL-8224E-A6	Assembly	2
11		Long arm	FL-8224-A7	Assembly	2
12		Short arm	TW-235E-A8	Assembly	2
13		Slot base plate	FL-8224-A9	Powder-coating	1
14		Base cover plate	FL-8224-A10	Powder-coating	1
Carton(include the following)					
17		Post cap	FL-8224E-A1-B6	ABS	2
18		Arm shaft	FL-8224 -A12	Zinc-plating	4
19					
20		Short feet-protection fender	FL-8224 -A18-B4	Powder-coating	2
21		Long feet-protection fender	FL-8224-A7-B4	Powder-coating	2
22		Lifting tray assembly	FL-8224 -A7-B3	Assembly	4
23		Rubber oil hose L=500mm		Assembly	1
24		Rubber oil hose L=2900mm	8224E-B4-B2	Assembly	1
25		Safety locking plate	FL-8224E -A1-B2	Zinc-plating	
26					
27		Positioning block	FL-8224E -A1-B3	Zinc-plating	
28		Hose & wire cover	FL-8224E -A1-B8	Powder-coating	6
29		Chain protection cloth	FL-8224 -A11	Assembly	2
30		Rod of chain protection cloth	FL-8224 -A13	Zinc-plating	4
31		Rubber protection pad	FL-8224 -A3-B7	Rubber	2
32		Nylon washer	FL-8224 -A17	Rubber	10
33					
34		Hex head full swivel nut	M10*35	Standard	4
35		Hex socket cylinder head screw	M8*12	Standard	8
36		Cross cap screw	M6*10	Standard	28
37		Cross cap screw	M6*30	Standard	12
38		Cross cap screw	M6*16	Standard	4
39		Cross sunken head screw	M8*16	Standard	4
40		Class C flat washer	M6	Standard	8
41		Class C flat washer	M10	Standard	4
42		Spring washer	M10	Standard	4
		Hex nut	M6	Standard	8
		Hex nut	M10	Standard	4
		Type B circlip	38	Standard	4
		Expansion bolt	M18*180	Standard	10

Attachment 2, Dimensions diagram

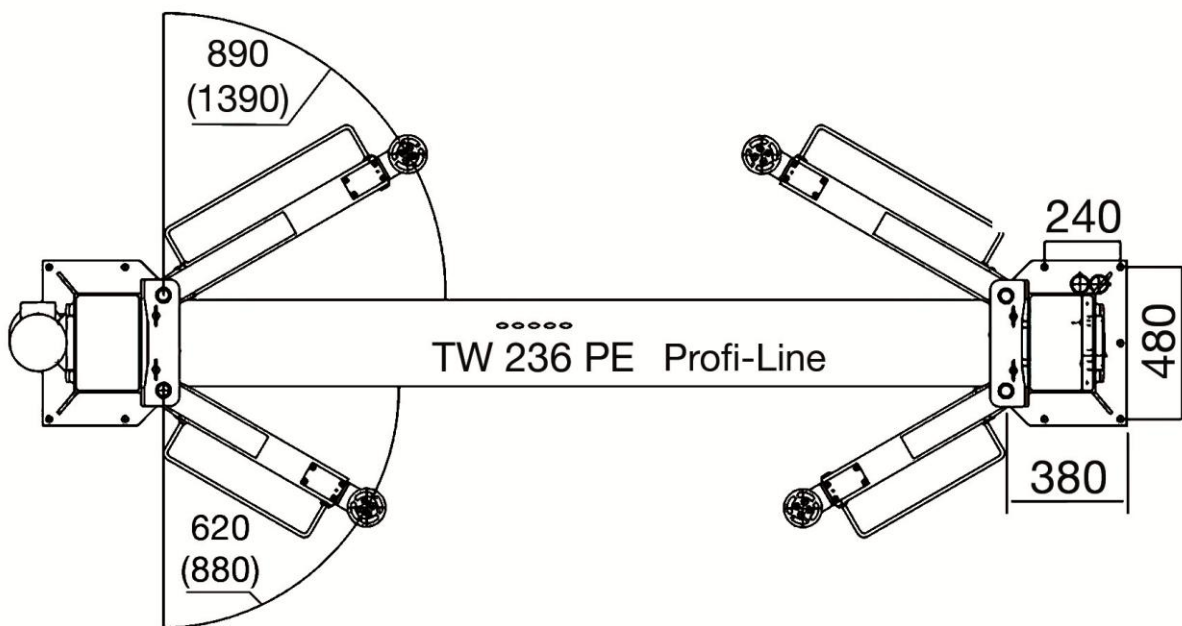
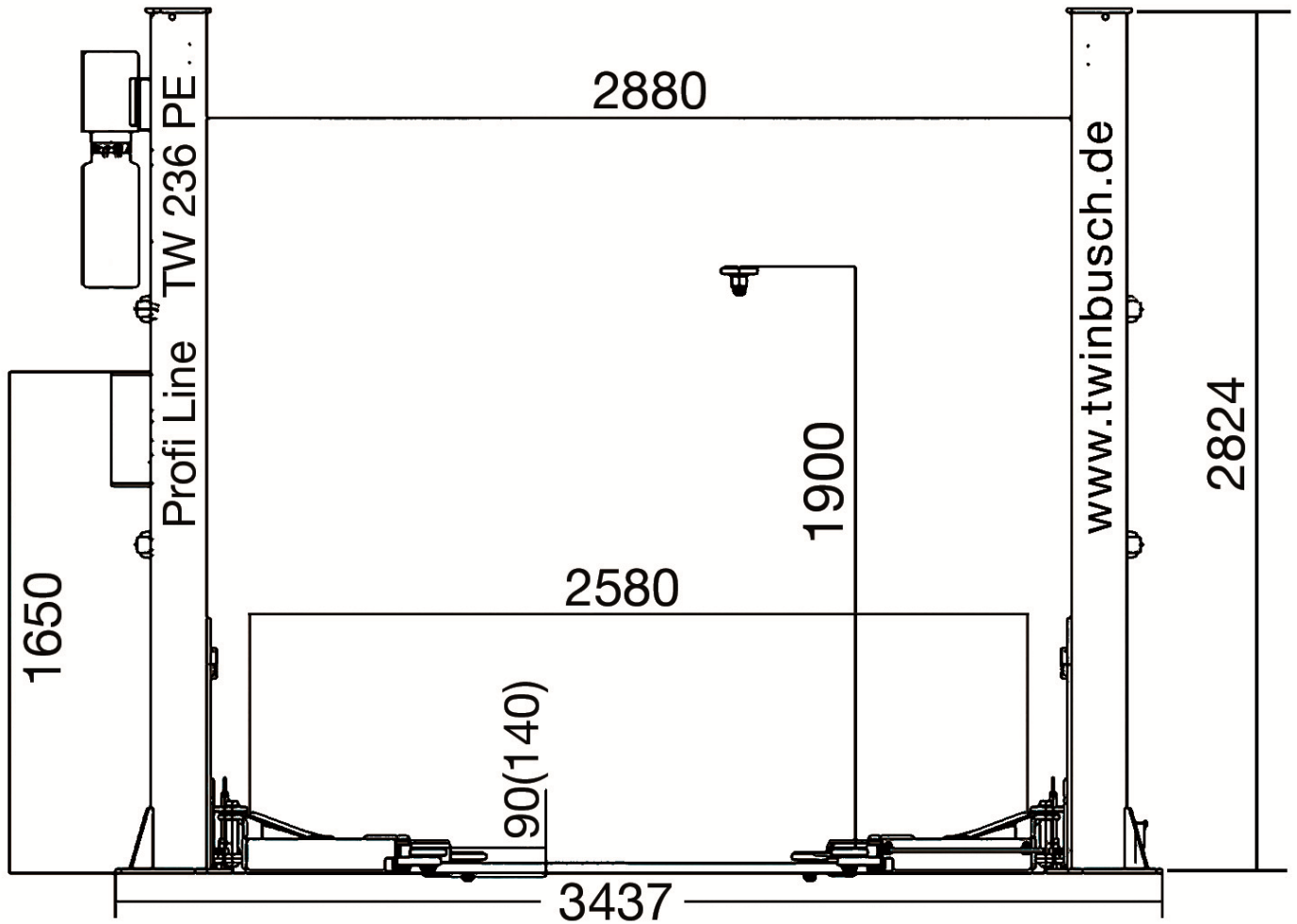

Weight Displacement

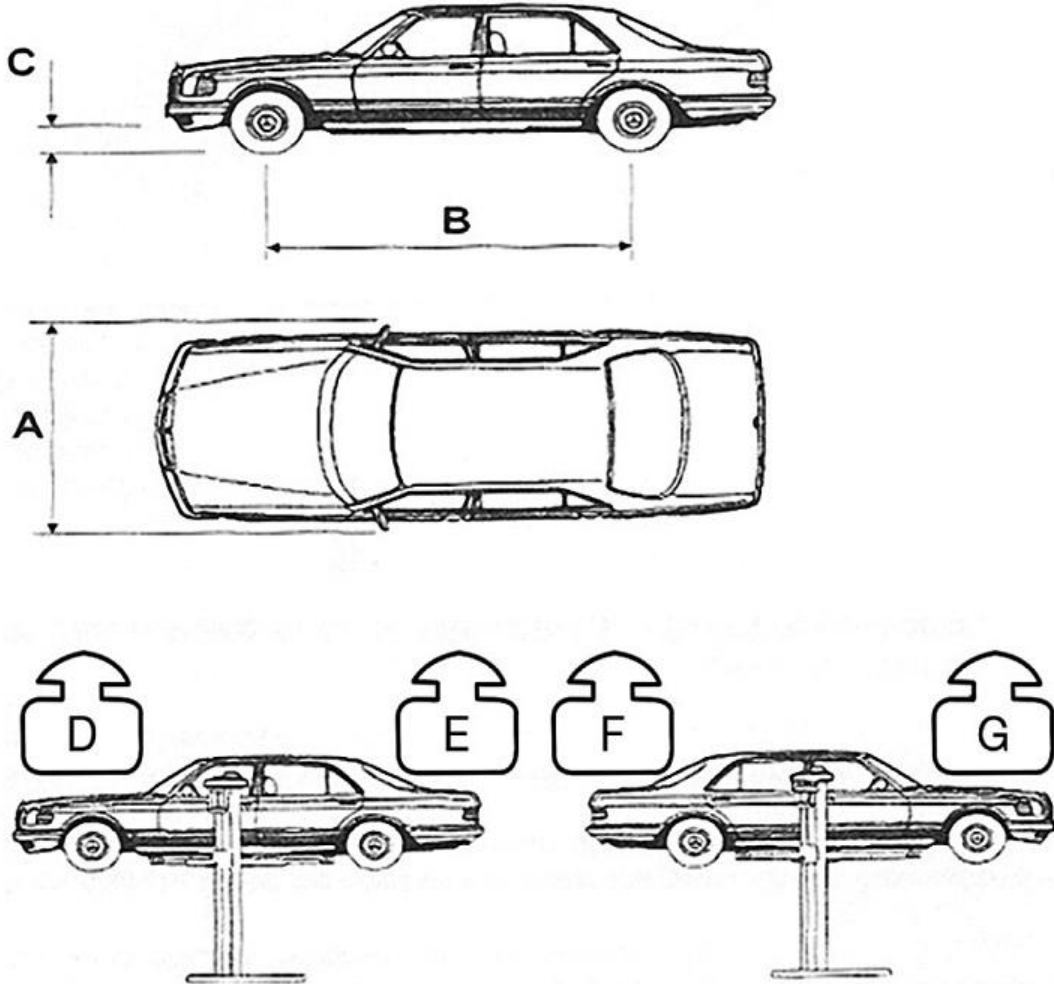

Modell	A (mm)	B (mm)	C (mm)	D (kg)	E (kg)	F (kg)	G (kg)
TW 236 PE	2400	2900	100	2100	1500	2100	1500

Attachment 3, Diagram for ground fixtures

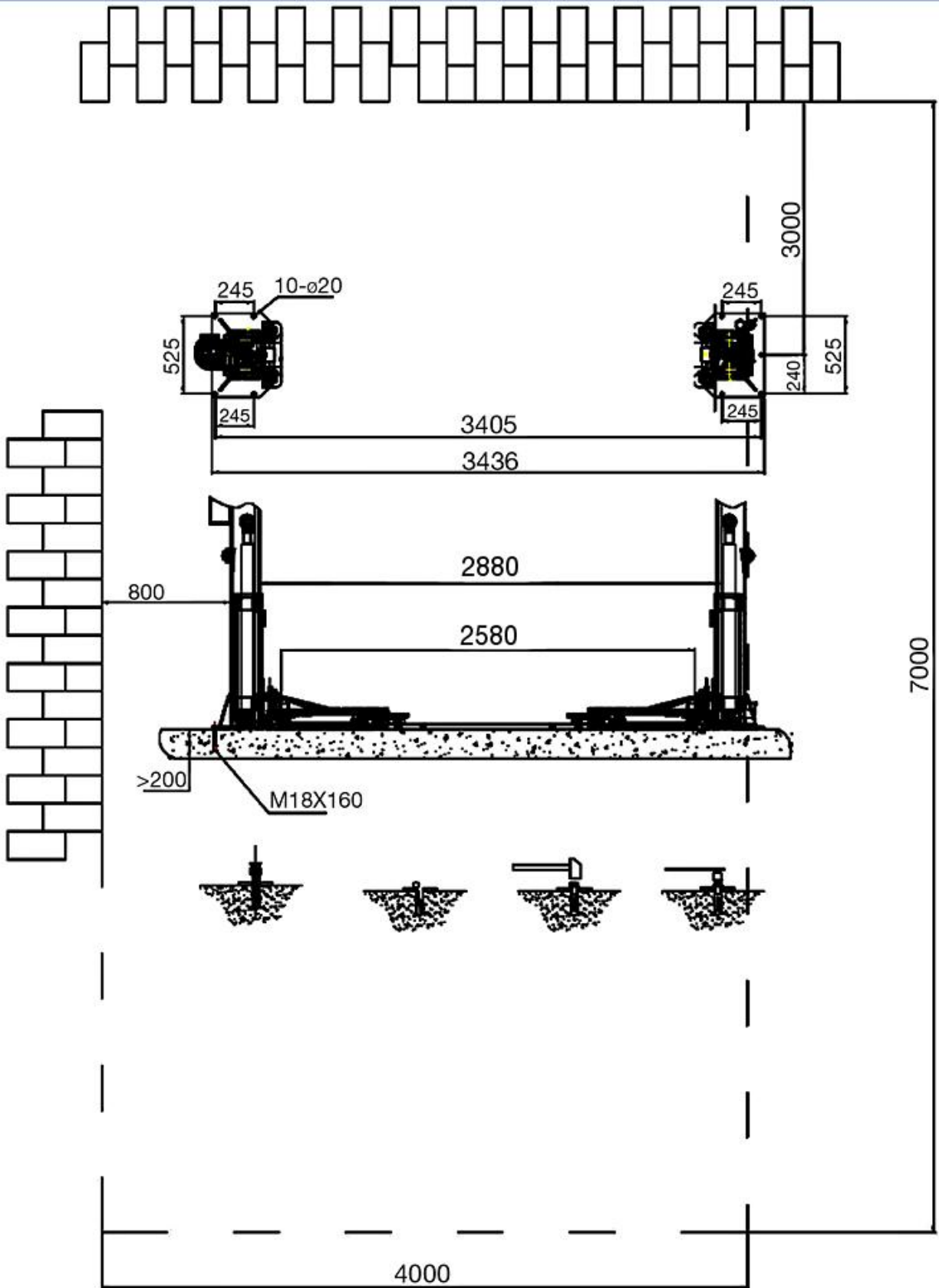

Requirements for the concrete floor:

- Concrete C20 / 25 according to DIN 1045-2 (Previously known as DIN 1045 concrete B25).
- Horizontal, accuracy of flatness smaller than 5 mm (0.2”).
- New concrete must dry for 28 days.

Foundation dimensions:

- Ideally, it's better to cover the whole area in concrete C20 / 25, 200 mm (up to 4 t) or 250 mm thick (5 t).

Minimum requirements: 2-Post lift 4 t:

4 m x 3 m x 0,2 m

(13 ft. x 10 ft. x 8 in.)

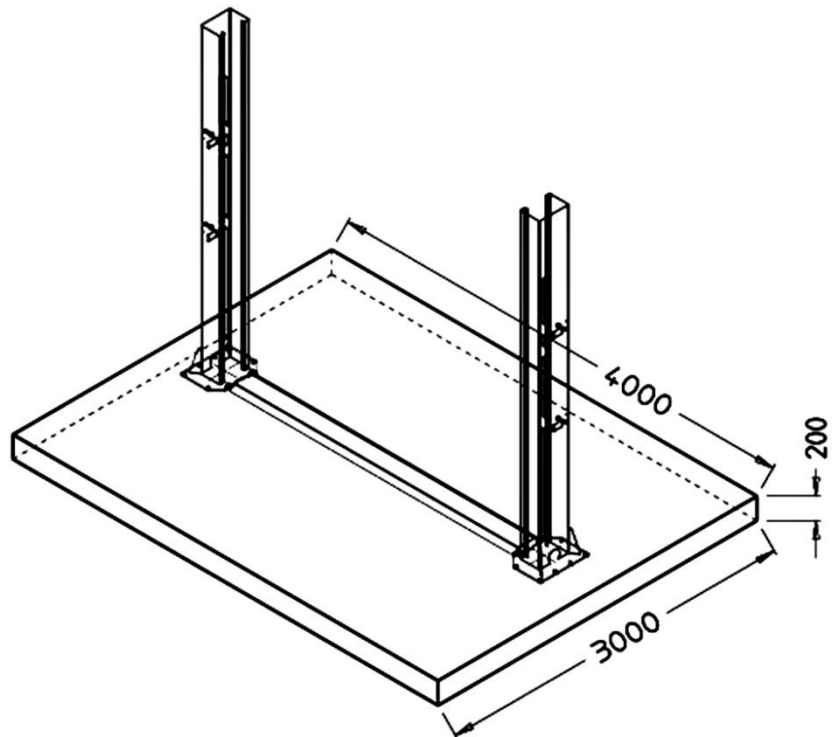

alternativ H-form

alternativ Block-form

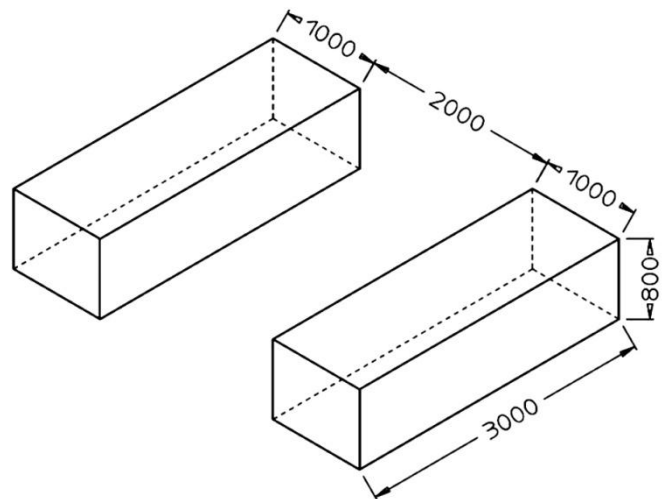
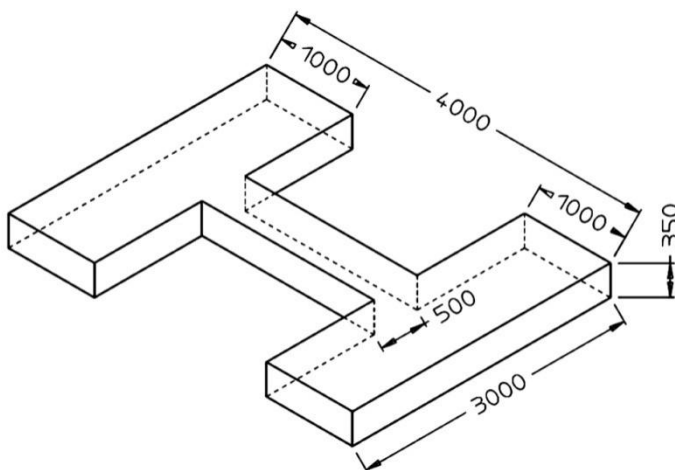

□ **Other requirements:**

- The surrounding ground must be suitable for the load, for example, no sand asphalt, etc..
- If in doubt, the foundation should always be checked by a structural engineer.

In case of frost, please note the following:

In cases of freezing the concrete should have exposure class XF4.

Thus, the following minimum requirements for the concrete in frost conditions:

Exposure class XF4

Maximum w / c: 0.45

Minimum compressive strength: C30 / 37 (instead of C20 / 25)

Minimum cement content 340 kg / m³

Minimum air content: 4.0%

It must however be noted that the lifting platforms not for use outdoors

The main switch corresponds to IP54, but remaining electrical parts, Motors and limit switches are designed to a maximum of IP44.

Expansion bolts

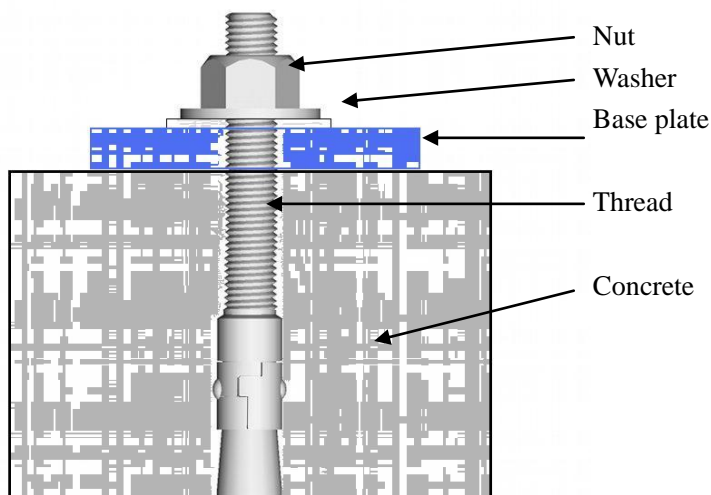

Expansion bolts should be tightened to 120 Nm.

Attachment 4, Hydraulic system

- 1. Main cylinder
- 2. Assistant cylinder
- 3. E-magnetic unloading valve
- 4. Throttle valve
- 5. Motor
- 6. Coupling
- 7. Gear pump
- 8. Single-way valve
- 9. Overflow valve
- 10. Anti-surge valve
- 11. Cushion valve
- 12. Emergent unloading valve

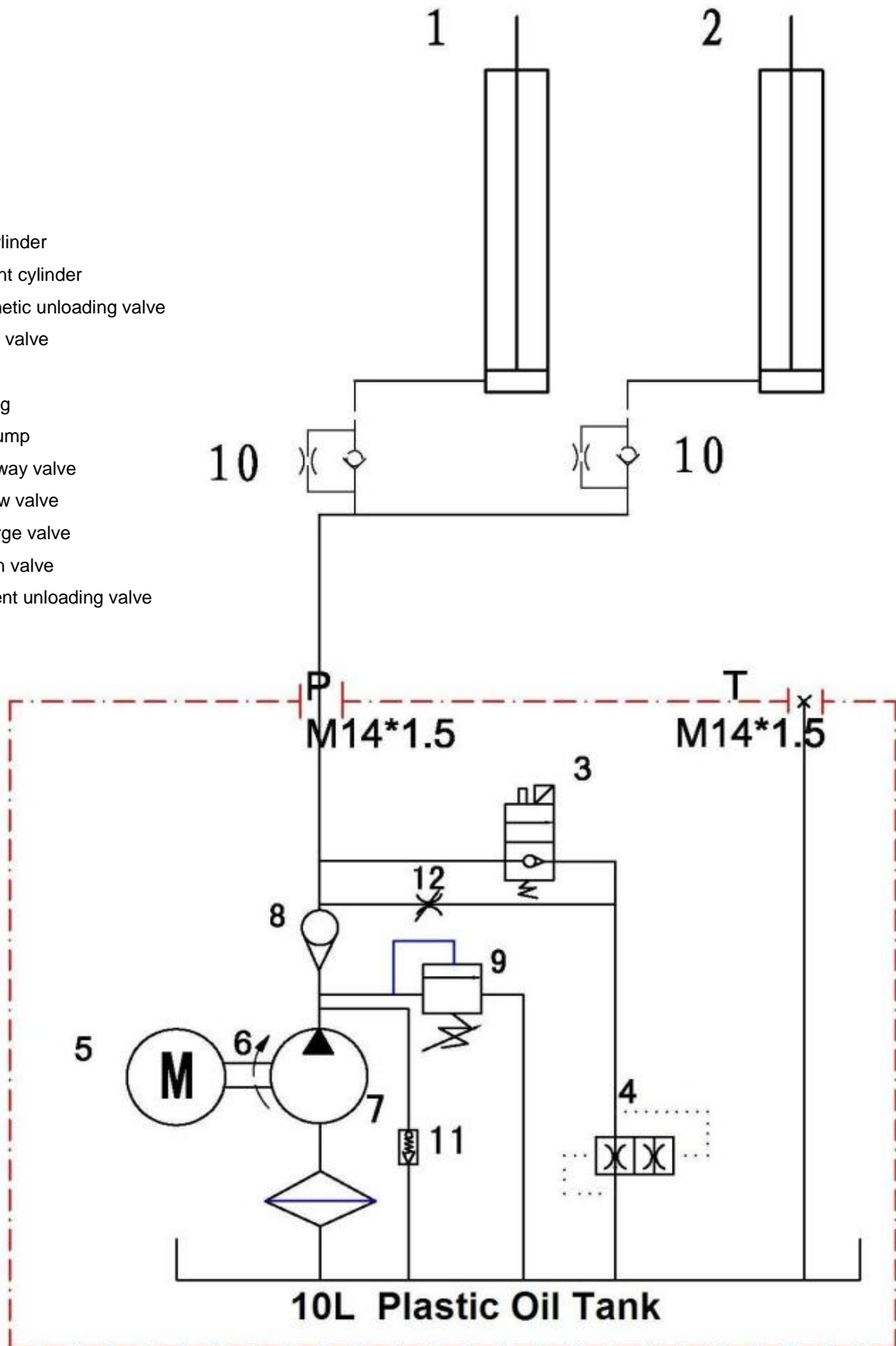

Attachment 5, Wiring diagram

Single phase

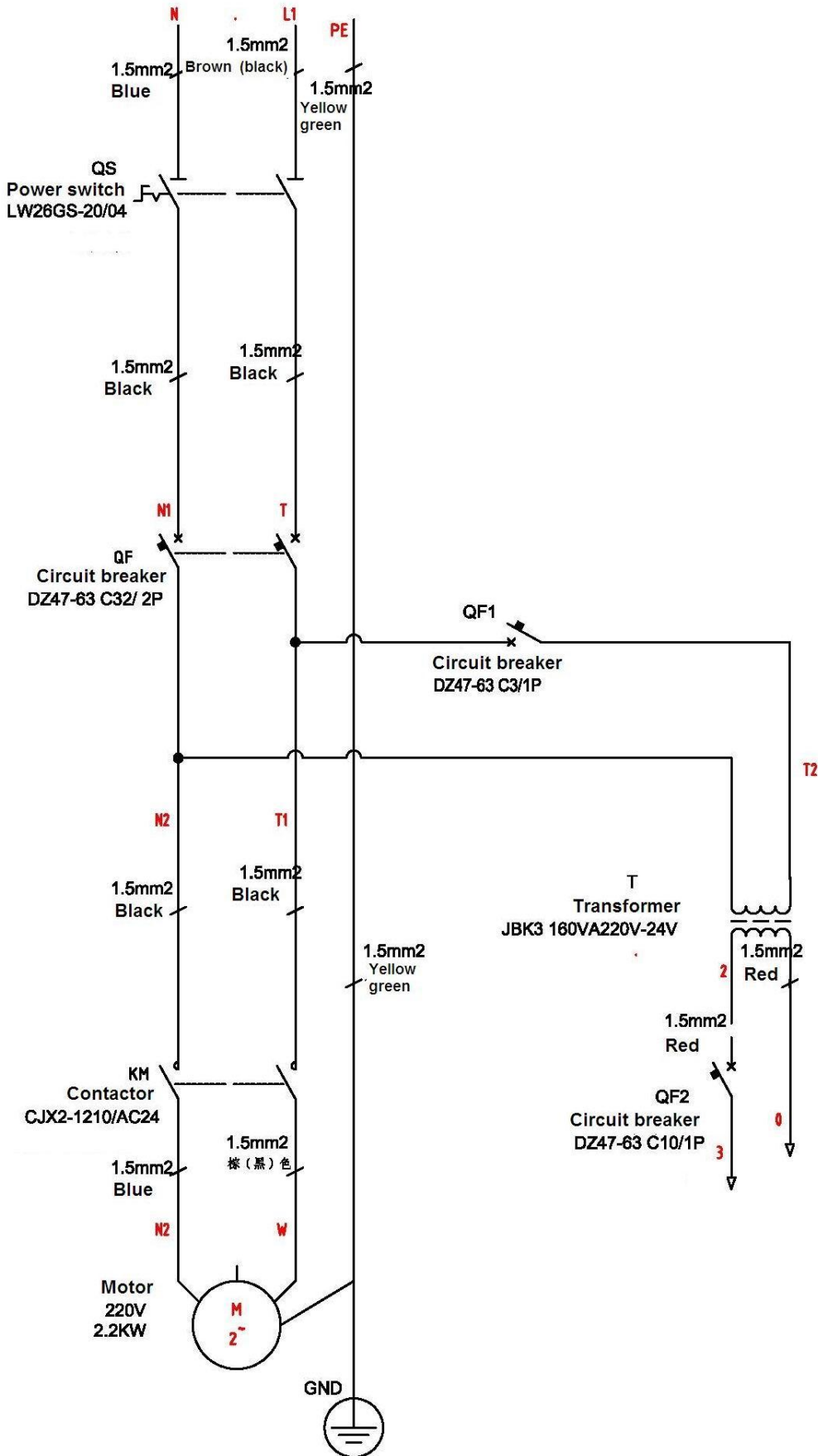

Three phase

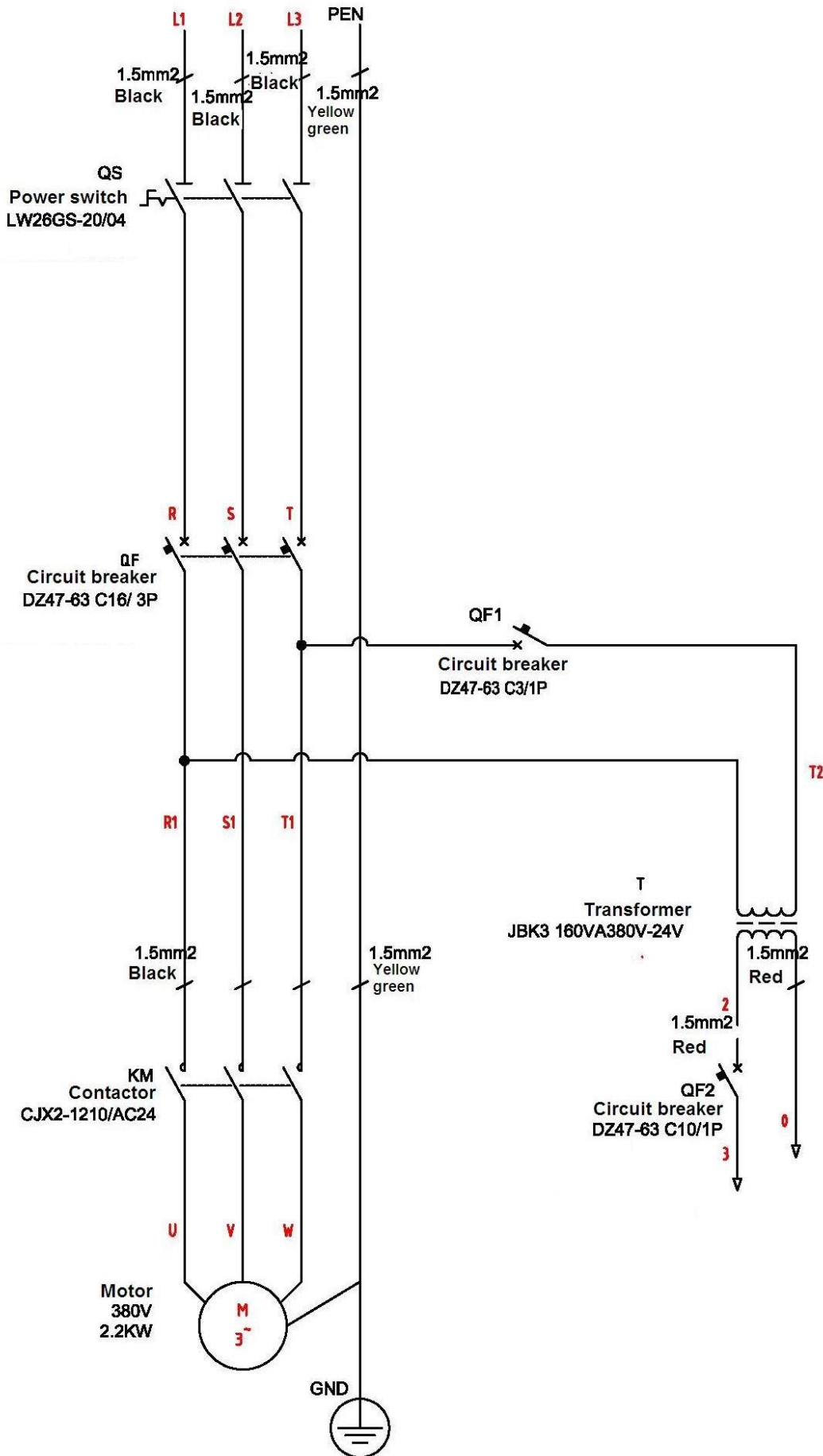

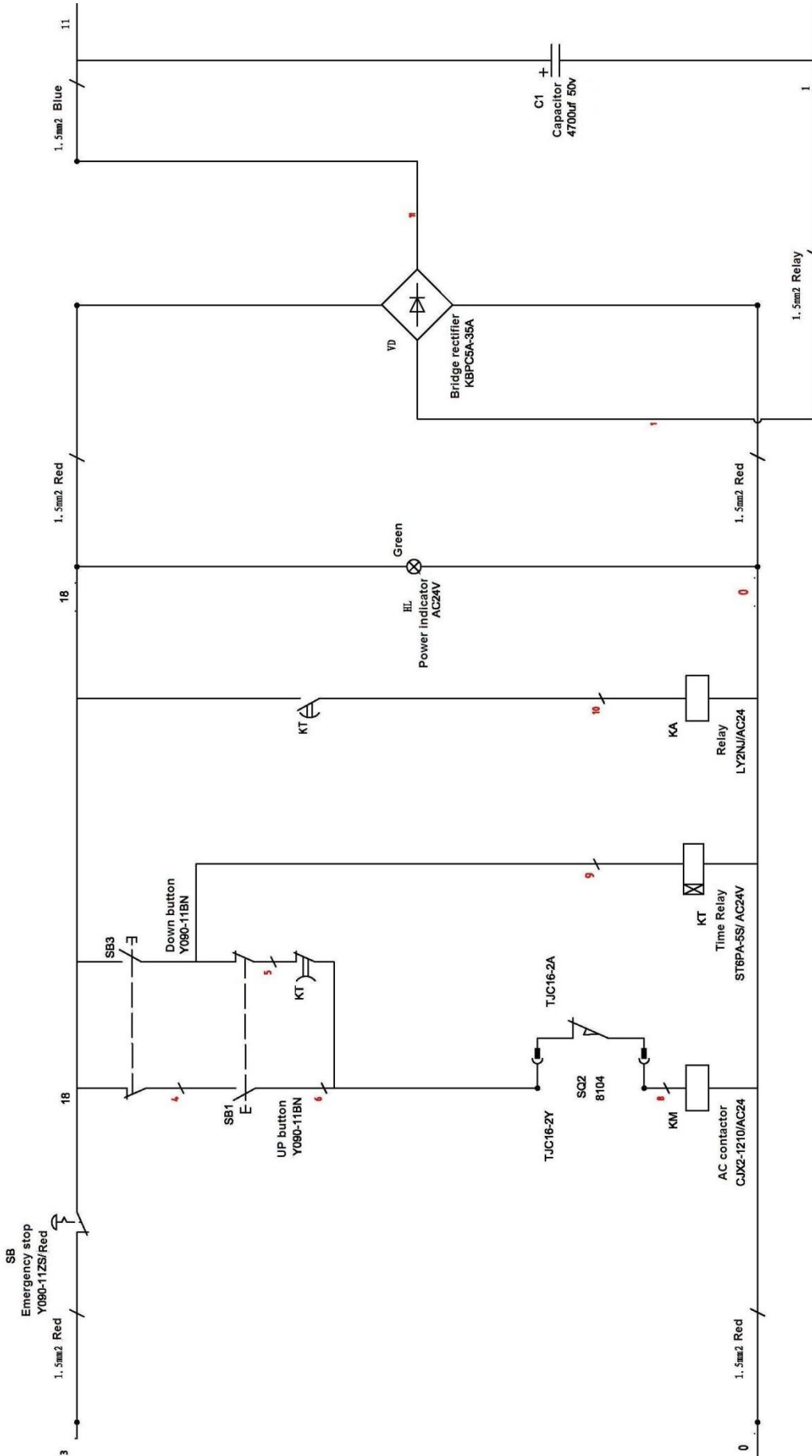

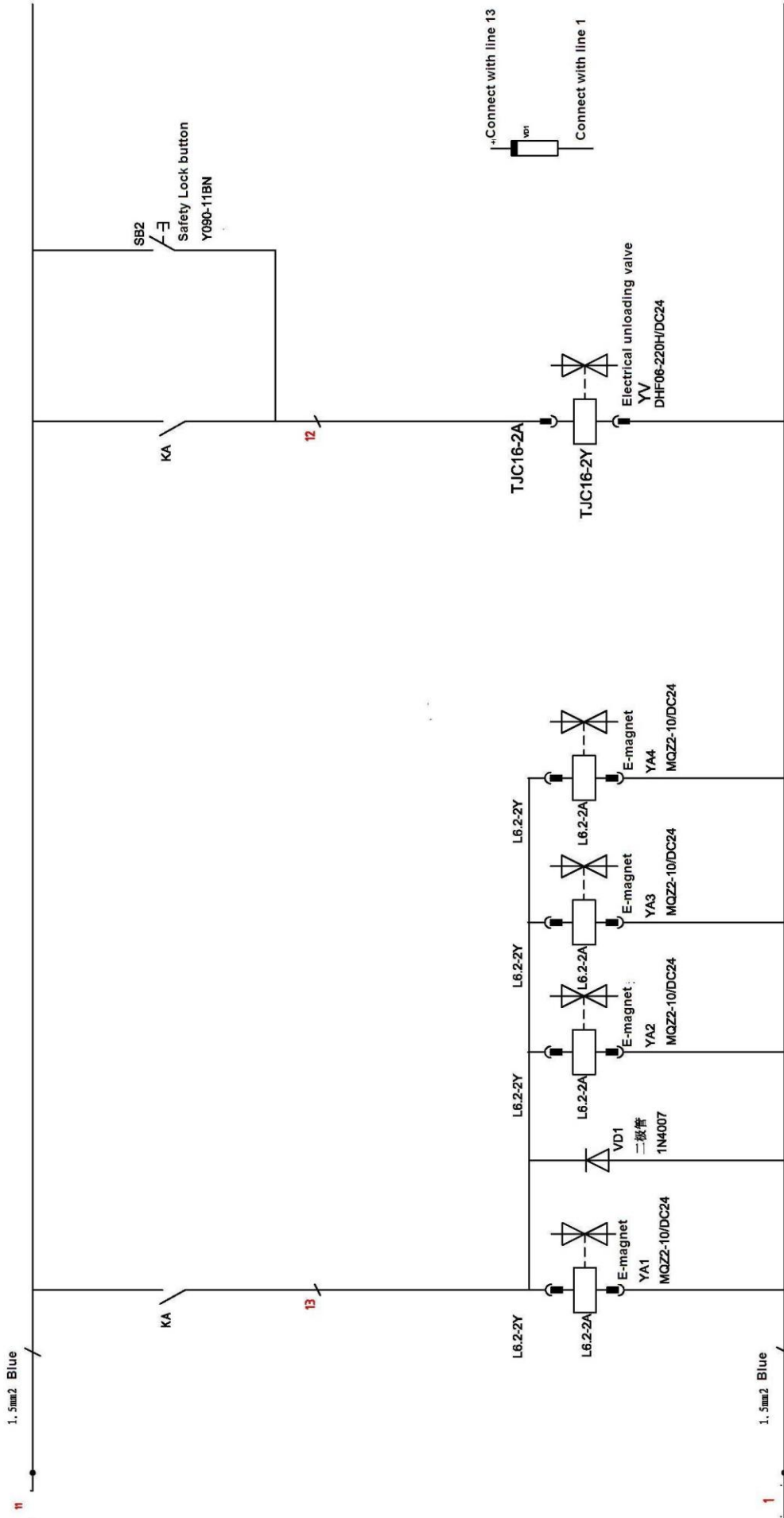

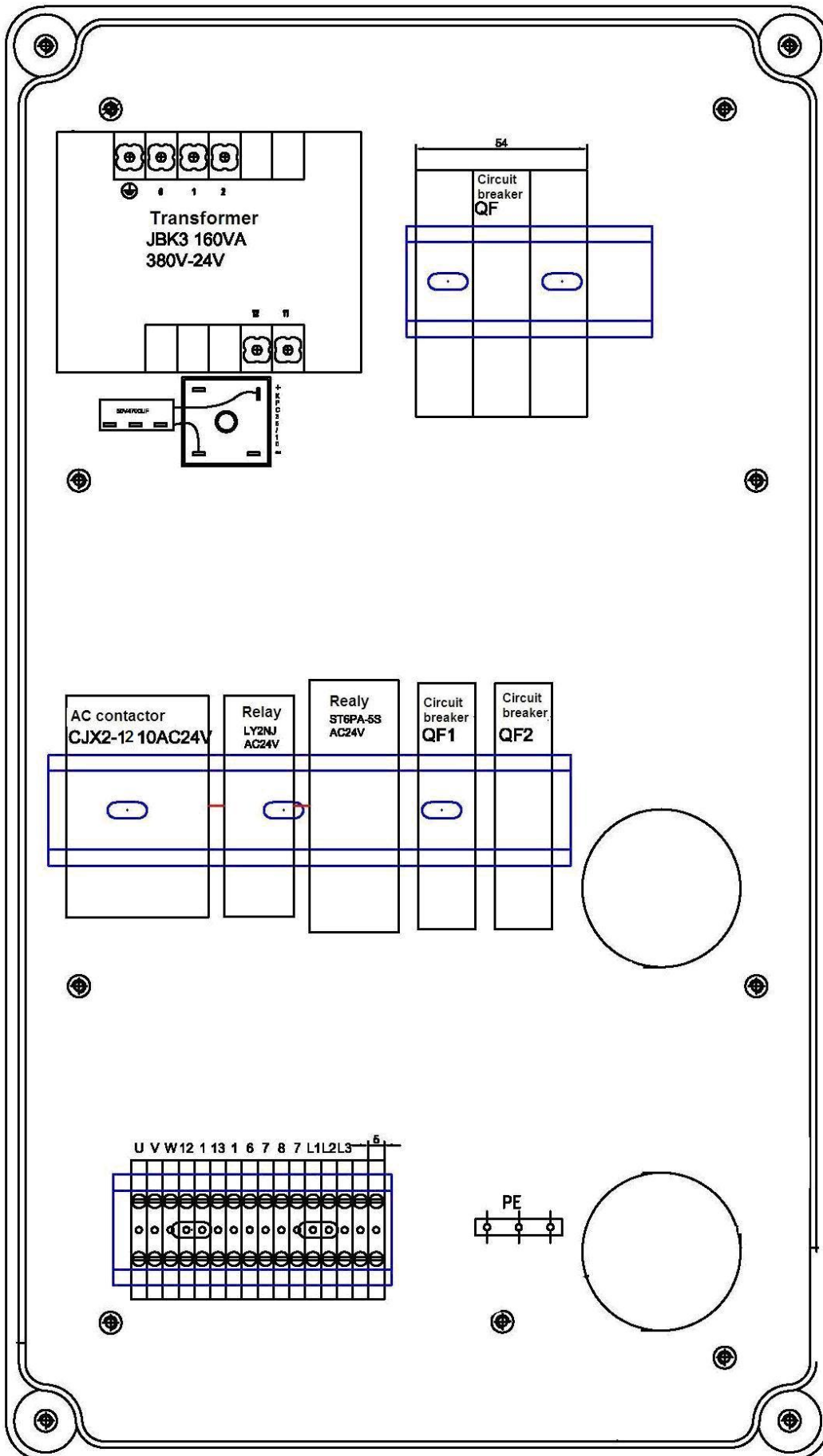

Attachment 6, Explosion drawings

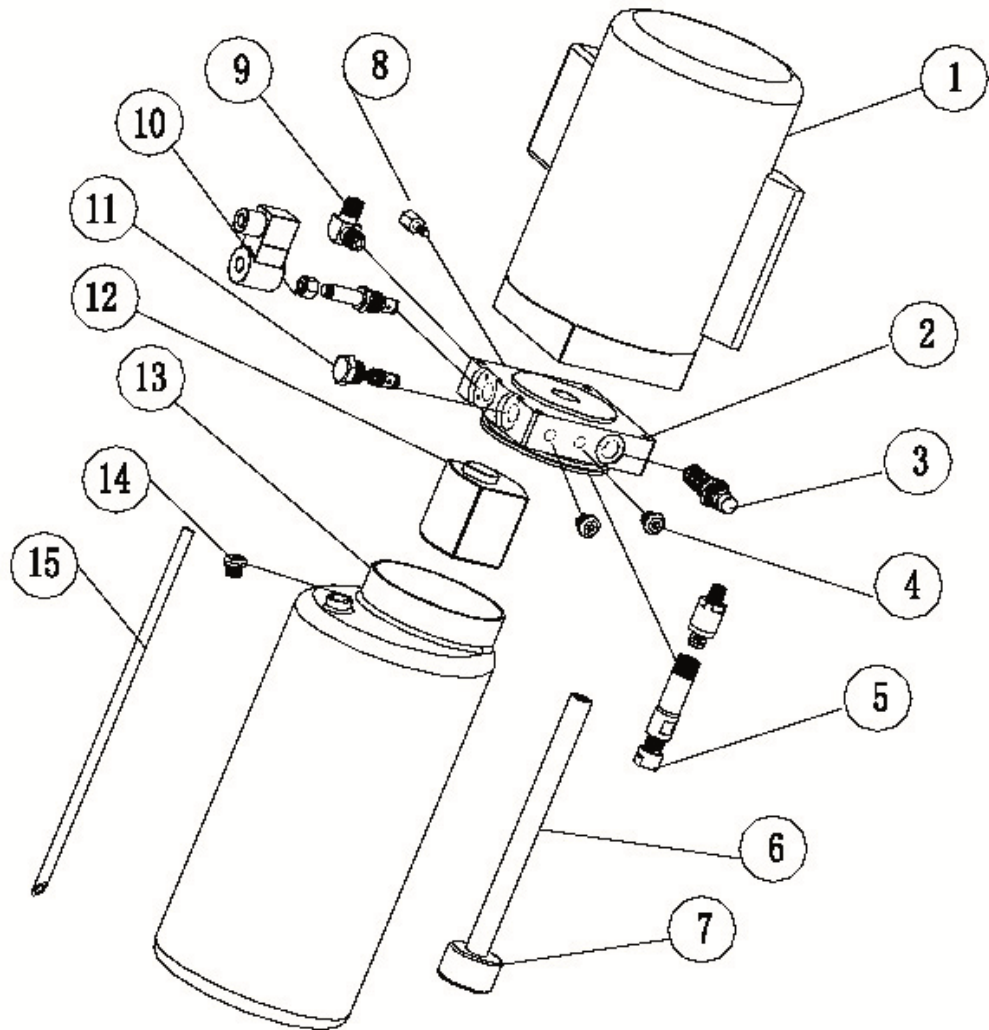

S/N	Name	Qty
1	Motor	1
2	Hydraulic block	1
3	Overflow valve	1
4	Removable plug	2
5	Cushion valve	1
6	Oil absorbing pipe	1
7	Oil filter	1
8	Throttle valve	1
9	Oil pipe tie-in	1
10	E-magnetic unloading valve	1
11	One-way valve	1
12	Gear pump	1
13	Plastic oil tank	1
14	Oil tank cover	1
15	Oil back pipe	1

S/N	Material #	Name	Drawing#	Qty	Property	Note
1		Steel cable L=8820mm	FL8224-A6	2	Assembly	
2		Hex nut M16	GB/T610-2000	8	Standard	
3		Class C flat washer M16	GB/T95-1985	4	Standard	
4		Expansion bolt M18*180		10	Standard	

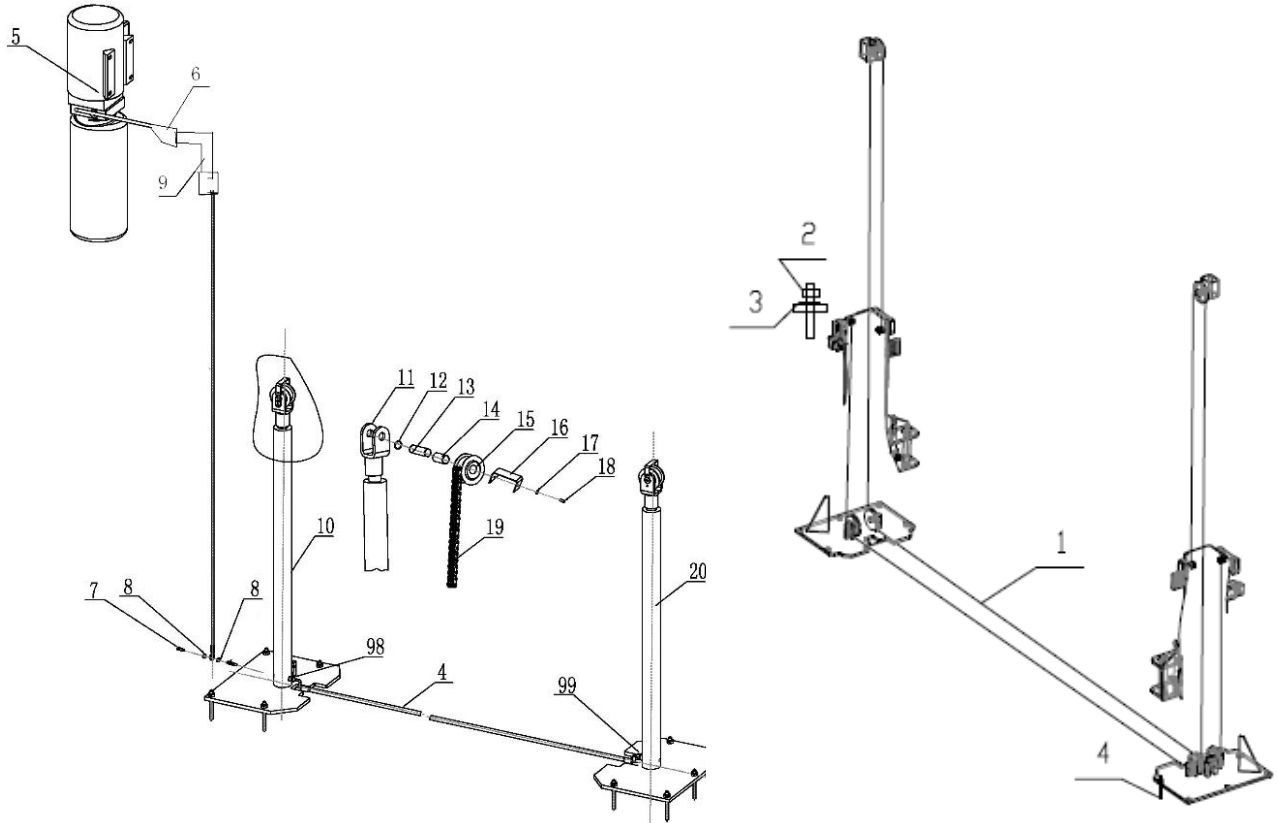

S/N	Material #	Name	Drawing#	Qty	Property	Note
4		Rubber oil hose L=2900		1	Assembly	
5		Power unit (electrical release)		1	Assembly	
6		PU oil hose L=500		1	Assembly	
7		Composite connector		2	Assembly	
8		Composite washer	Match with 1/4connector	4	Standard	
9		Square Connector		1	Assembly	
10		Drive oil cylinder	FL-8224-A4-B2	1	Assembly	
11		Chain wheel bracket	FL-8224-A4-B9	2	Zinc -plating	
12		Type B circlip 25	GB/T894.2-1986	4	Standard	
13		Chain wheel shaft	FL-8224-A4-B11	2	Zinc -plating	
14		Bearing 2548	SF-1	2	Standard	
15		Chain wheel	FL-8224-A4-B10	2	Zinc -plating	
16		Baffle plate	FL-8224-A4-B12	2	Zinc -plating	
17		Spring washer M6	GB/T93-1987	4	Standard	
18		Inside hex cylinder head screw M6*10	GB/T70.1-2000	4	Standard	
19		Chain	LH1234-127LGB/6074-1995	2	Standard	
20		Assistant oil cylinder	FL-8224-A4-B3	1	Assembly	
98		Main oil cylinder connector	FL-8224-A4-B4	1	Zinc -plating	
99		Assistant oil cylinder connector	FL-8224-A4-B5	1	Zinc -plating	

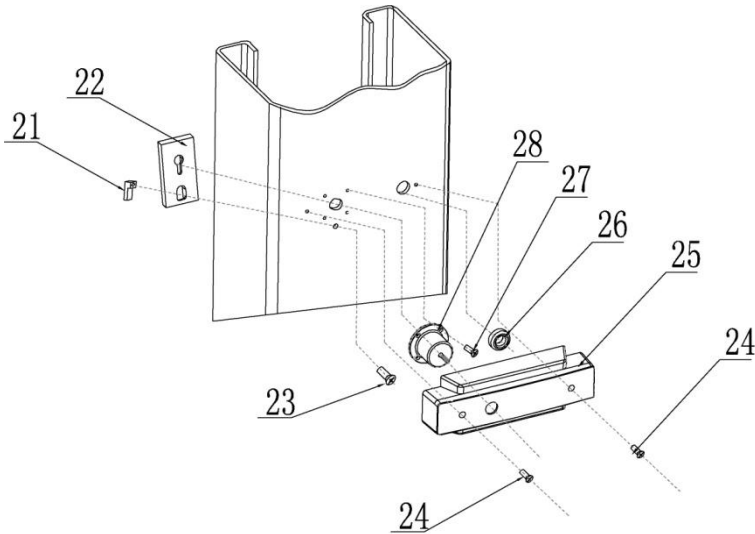

S/N	Material #	Name	Drawing#	Qty	Property	Note
21		Positioning block	FL-8224E-A1-B3	4	Zinc-plating	
22		Safety locking plate	FL-8224E-A1-B2	4	Zinc-plating	
23		Cross cap screw M6*16	GB/T818-2000	4	Standard	
24		Cross cap screw M5*10	GB/T818-2000	8	Standard	
25		Electromagnet protection cover	FL-8224E-A1-B5	4	Plastic	
26		φ20 hose clip	FL-8224-A1-B6	2	Rubber	
27		Cross cap screw M5*10	GB/T818-2000	16	Standard	
28		Tractive electromagnet	FL-8224E-A1-B6	4	Assembly	

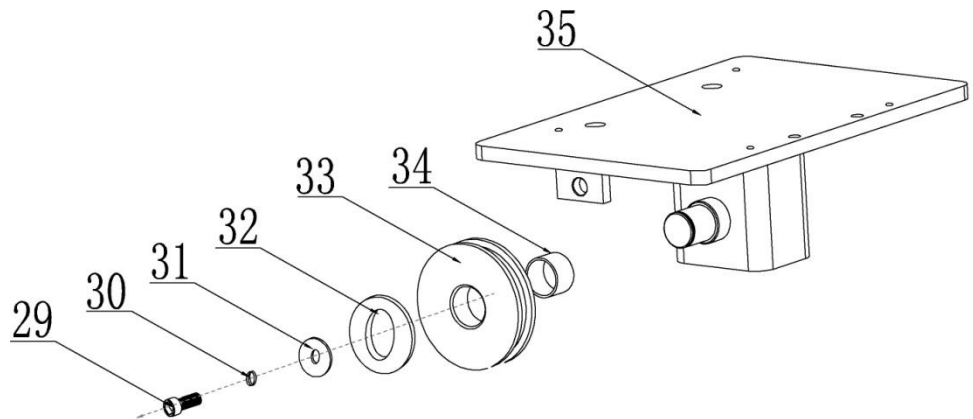

S/N	Material #	Name	Drawing#	Qty	Property	Note
29		Hex socket cylinder head screw M8*20	GB/T70. 2-2000	2	Standard	
30		Spring washer M8	GB/T93-1987	2	Standard	
31		Retaining ring	FL-8224-A1-B3-C	2	Zinc-plating	
32		Washer	GB/T894. 2-1986	2	Zinc-plating	
33		Up pulley	FL-8224-A1-B2	2	Zinc-plating	
34		Bearing 2518	SF-1	2	Standard	
35		Top plate	FL-8224-A1-B3-C	2	Welded	

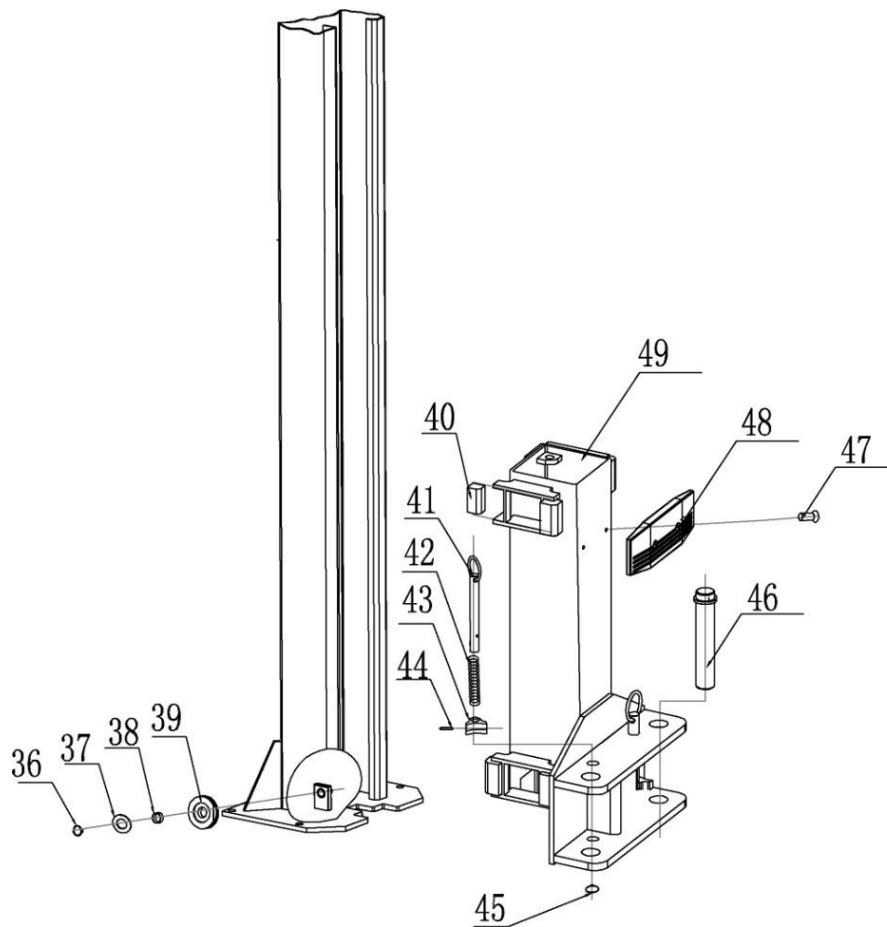

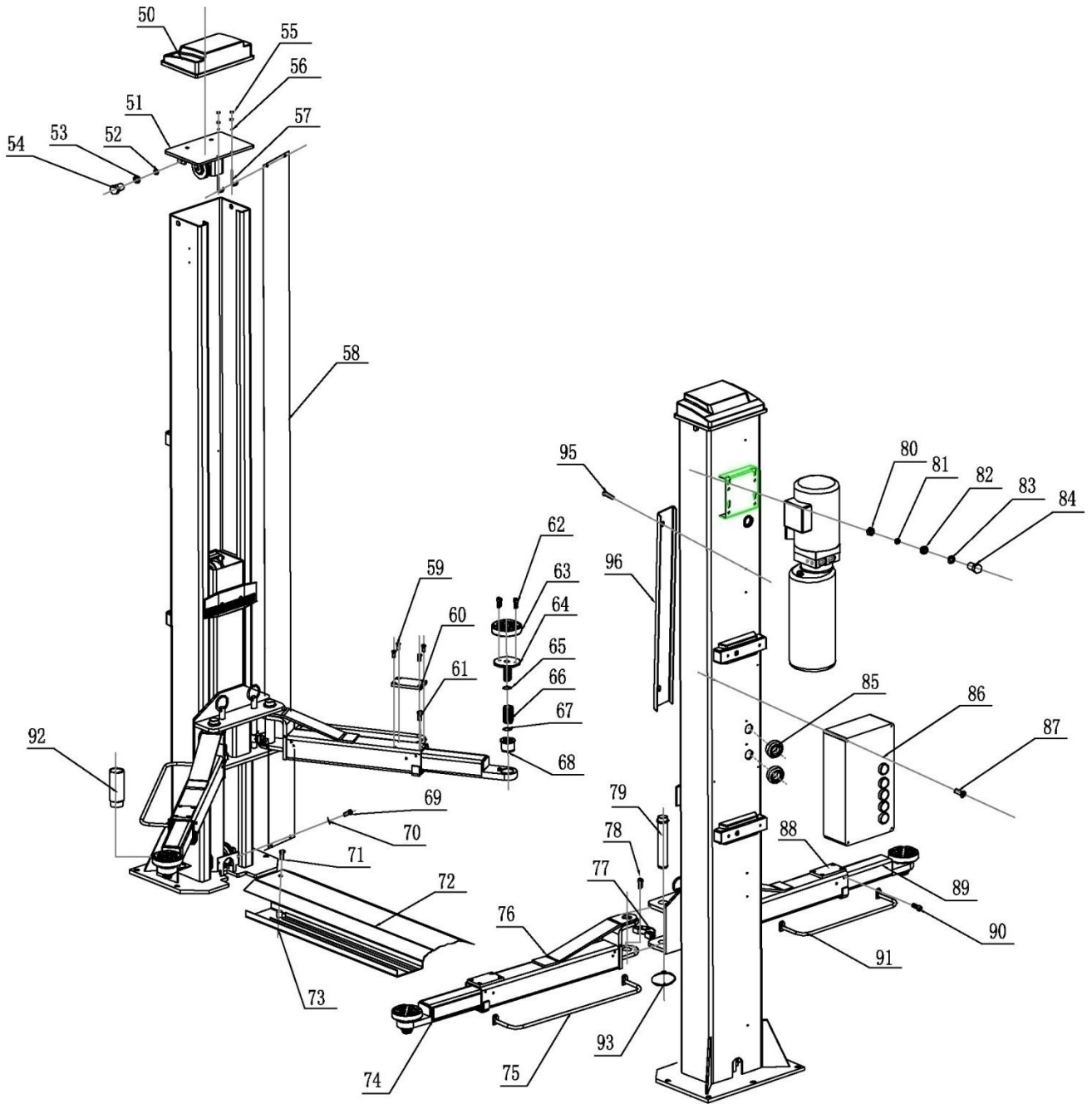

S/N	Material #	Name	Drawing#	Qty	Property	Note
36		Type B circlip 25	GB/T894.2-1986	4	Standard	
37						
38		Bearing 2516	SF-1	4	Standard	
39		Down pulley	FL-8224-A1-B2	4	Zinc-plating	
40		Slider	FL-8224-A3-B6	16	Nylon	
41		Pulling rod	FL-8224-A3-B2	4	Zinc-plating	
42		Pressure spring	FL-8224-A3-B5	4	Zinc-plating	
43		Teeth block	FL-8224-A3-B6	4	Zinc-plating	
44		Elastic pin 5*35	GB/T879.1-2000	4	Standard	
45		Type B circlip 22	GB/T894.2-1986	4	Standard	
46		Pin shaft assembly	FL-8224E-A12	4	Zinc-plating	
47		Cross socket flat head screw M8*16	GB/T819.1-2000	4	Standard	
48		Protection rubber pad	FL-8224-A3-B7	2	Rubber	
49		Carriage assembly	FL-8224-A3-B1	2	Welded	





S/N	Material #	Name	Drawing#	Qty	Property	Note
51		Top plate	FL-8224-A1-B3	2	Assembly	
52		Class C flat washer M12	GB/T95-1985	4	Standard	
53		Spring washer M12	GB/T93-1987	4	Standard	
54		Hex head full swivel screw M12*20	GB/T5781-2000	4	Standard	
55		Hex nut M6	GB/T6170-2000	8	Standard	
56		Class C flat washer M6	GB/T95-1985	4	Standard	
57		Rod of chain protection cloth	FL-8224-A13	4	Standard	
58		Chain protection	FL-8224-A11	2	Cloth	
59		Cross socket flat head screw M5*10	GB/T819.1-2000	16	Standard	
60		Rectangular protection pad	FL-8224-A7-B7	4	Rubber	
61		Cross socket flat head screw M8*10	GB/T819.1-2000	4	Standard	
62		Inside hex sunken head screw M8*20	GB/T70.3-2000	8	Standard	
63		Round lifting pad	FL-8224-A7-B3-C4	4	Rubber	
64		Lifting tray	FL-8224-A7-B3-C1	4	Assembly	
65		Type B circlip 22	GB/T894.2-1986	4	Standard	
66		Swivel sheath	FL-8224-A7-B3-C2	4	Q235A	
67		Circlip 38*2.5	GB/T895.2-1986	8	Standard	
68		Inside swivel sheath	FL-8224-A7-B3-C3	4	Q235A	
69		Cross cap screw M6*8	GB/T818-2000	4	Standard	
70		Class C flat washer M6	GB/T95-1985	4	Standard	
71		Inside hex sunken head screw M12*20	GB/T70.3-2000	2	Standard	
72		Base plate	FL-8224-A10	1	Q235A	
73		Slot base plate	FL-8224-A9	1	Welded	
74		Long tensile arm	FL-8224-A7-B2	2	Welded	
75		Long feet protection fender	FL-8224-A7-B4	2	Welded	
76		Long arm	FL-8224-A7-B1	2	Welded	
77		Teeth block	FL-8224-A7-B5	4	Q235A	
78		Hex socket cap screw M10*20	GB/T70.1-2000	12	Standard	
79		Arm shaft	FL-8224-A12	4	Welded	
80		Hex nut M8	GB/T6170-2000	4	Standard	
81		Spring washer M8	GB/T93-1987	4	Standard	
82		Anti-shock pad	FL-8224-A14	4	Rubber	
83		Class C flat washer M8	GB/T95-1985	4	Standard	
84		Hex head full swivel screw M8*35	GB/T5781-2000	4	Standard	
85		Φ40 hose clip	FL-8224-A1-B7	2	Rubber	
86		Control box	FL-8224E	1	Assembly	
87		Cross cap screw M5*10	GB/T818-2000	4	Standard	
88		Short arm	FL-8224-A18-B1	2	Welded	
89		Short tensile arm	TW-235E-A20-B1	2	Welded	
90		Hex socket cylinder head screw M8*12	GB/T70.2-2000	8	Standard	
91		Short feet protection fender	FL-8224-A18-B4	2	Welded	
92		Height adapter	FL-8224-A15	4	Welded	
93		Type B circlip 38	GB/T894.2-1986	4	Standard	
S/N	Material #	Name	Drawing#	Qty	Property	Note
961		Slide wire cover	FL-8224-A13-B8	6	Q235A	

2		Rubber lifting pad	FL-8224-A7-B3-C4	4	Rubber	
3		Y-shape seal ring	KD 63*48*10	1		
4		O-shape seal ring	(ID)23.6*3.55	1		
5		Anti-dust ring	DHS 40*48*5/6.5	1		

Attachment 7, Spare parts list

S/N	Material #	Name	Spec.	Qty	Pic.	Note
1		Power switch	LW26GS-20/04	1		
2		Button	LAY711BN12	1		
3		Power indicator	AD17-22G-AC24	1		
4		Transformer	JBK3-160VA400V-24V JBK3-160VA230V-24V	1		
5		AC contactor	CJX2-1210/AC24V	1		
6		Circuit breaker	DZ47-63 C16/3P DZ47-63 C32/2P	1		
7		Circuit breaker	DZ47-63 C3/1P	1		
9		Limit switch	ME8104	1		
11		Emergency stop	LAY701ZS42	1		
12		Bridge rectifier	KBPC5A-35A	1		
13		Capacitor	4700UF/50A	1		
14		Relay	LY2NJ/AC24	1		
15		Relay holder	PTF-08A	1		
16		time relay	ST6PA-5S/AC24V	1		

S/N	Material #	Name	Spec.	Qty	Pic.	Note
17		Time relay holder	PYF-08AE	1		
18		Control box	380*260*135	1		



Space for notes:



Space for notes:



Inspection findings

Regular/ extraordinary inspection

On the date of this lift was put through a regular/ extraordinary and thorough inspection. During this inspection these issues were/ were not found.

Scope of the audit:

Outstanding partial inspection:

The use of this equipment is authorized and the machine and all features have been inspected .

Location/ Date	Inspectors signature
----------------	----------------------

Operator or agent

Taken notes of the defects

Defect corrected
Date Signature

Verification

Date Signature

On the date of this lift was put through re-inspection. During this inspection these issues were/ were not found.

The use of this equipment is authorized and the machine and all features have been inspected.

Location/ Date	Inspectors signature
----------------	----------------------



Safety review pursuant to UVV type

Safety inspection before commissioning/ regular checks/ extraordinary
(Mark off those that do not apply)

Inspection	Good shape	defective	Re-inspection	Notes
Warning labels/ signs				
Name plate/ ID				
Limit switch function				
Condition of rubber plates				
Function of carrier arm locks				
Supporting structure (cracks etc.)				
Function of safety latches				
All screws tight				
Condition of steel cables				
Condition of covers				
Condition of chain				
Condition of cable pulleys				
Condition of hydraulic lines				
Fluid level of hydraulic unit				
Hydraulic system seals				
Condition of the piston rod				
Condition of electronics				
Function test of the lift				
Foundation condition (cracks)				
Lift Slides/guides in the lift column				
Other				
(Check the appropriate box, if re-inspection is necessary mark that box as well!)				

Inspector (Name, Address):

Inspected on:

Inspection result:

- Commissioning/ use possible. Resolve issues by
- Commissioning/ use prohibited. Re-inspection necessary.
- No defects. Commissioning/ use possible.

Signature owner/ operator:

Signature inspector:



Inspection findings

Regular/ extraordinary inspection

On the date of this lift was put through a regular/ extraordinary and thorough inspection. During this inspection these issues were/ were not found.

Scope of the audit:

Outstanding partial inspection:

The use of this equipment is authorized and the machine and all features have been inspected .

Location/ Date

Inspectors signature

Operator or agent

Taken notes of the defects

Defect corrected
Date Signature

Verification

Date Signature

On the date of this lift was put through re-inspection. During this inspection these issues were/ were not found.

The use of this equipment is authorized and the machine and all features have been inspected.

Location/ Date

Inspectors signature



Safety review pursuant to UVV type

Safety inspection before commissioning/ regular checks/ extraordinary

(Mark off those that do not apply)

Inspection	Good shape	defective	Re-inspection	Notes
Warning labels/ signs				
Name plate/ ID				
Limit switch function				
Condition of rubber plates				
Function of carrier arm locks				
Supporting structure (cracks etc.)				
Function of safety latches				
All screws tight				
Condition of steel cables				
Condition of covers				
Condition of chain				
Condition of cable pulleys				
Condition of hydraulic lines				
Fluid level of hydraulic unit				
Hydraulic system seals				
Condition of the piston rod				
Condition of electronics				
Function test of the lift				
Foundation condition (cracks)				
Lift Slides/guides in the lift column				
Other				
(Check the appropriate box, if re-inspection is necessary mark that box as well!)				

Inspector (Name, Address):

Inspected on:

Inspection result:

- Commissioning/ use possible. Resolve issues by
- Commissioning/ use prohibited. Re-inspection necessary.
- No defects. Commissioning/ use possible.

Signature owner/ operator:

Signature inspector:



The company

Twin Busch GmbH | Amperestr. 1 | D-64625 Bensheim

declares hereby, that the **2-post vehicle lift**

TW 236 PE + 236 PE B3.9 | 3600 kg

TW 246 PE + 242 PE B3.9 | 4200 kg

serial no.

in the configuration placed on the market by us, meets the relevant safety and health requirements, as required by the following EC directive(s) in it's/their current version(s).

EC-directive(s)

2006/42/EC Maschinen, 2006/95/EC Niederspannung

Applied harmonized standards and regulations

EN 1493:2010 Car lifts

EN 60204-1:2006/A1:2009 Safety of machinery - Electrical equipment of machines

CE Certificate

N8M 15 04 87411 016

date of issue: 20.04.2015

M6A 15 04 87411 015

place of issue: München

technical file no.: 646821 401002

Certification body

TÜV Süd Product Service GmbH,

Ridlerstraße 65,

D-80339 München

Notified Body Appointment No. 0123

Any alteration to the equipment, improper use or installation void this declaration.

Authorized person to compile technical documentation is: Michael Glade (adress as below)



TWIN BUSCH GmbH

Amperestr. 1 · 64625 Bensheim
Tel. 08251 / 70585-0 · Fax: 70585-28

Authorized signatory: Michael Glade

Bensheim, 23.06.15 Qualitätsmanagement

Twin Busch GmbH | Amperestr. 1 | D-64625 Bensheim

twinbusch.de | E-Mail: info@twinbusch.de | Tel.: +49 (0)6251-70585-0



Twin Busch GmbH | Amperestraße 1 | D-64625 Bensheim
Tel.: +49 (0) 6251-70585-0 | Fax: +49 (0) 6251-70585-29 | info@twinbusch.de