

Model No. EE-MS12M
Mobile Lifting Table
Lifting Capacity, 1200KG/2700lbs.

TRANSLATED VERSION
Installation, Operation
and Parts Manual

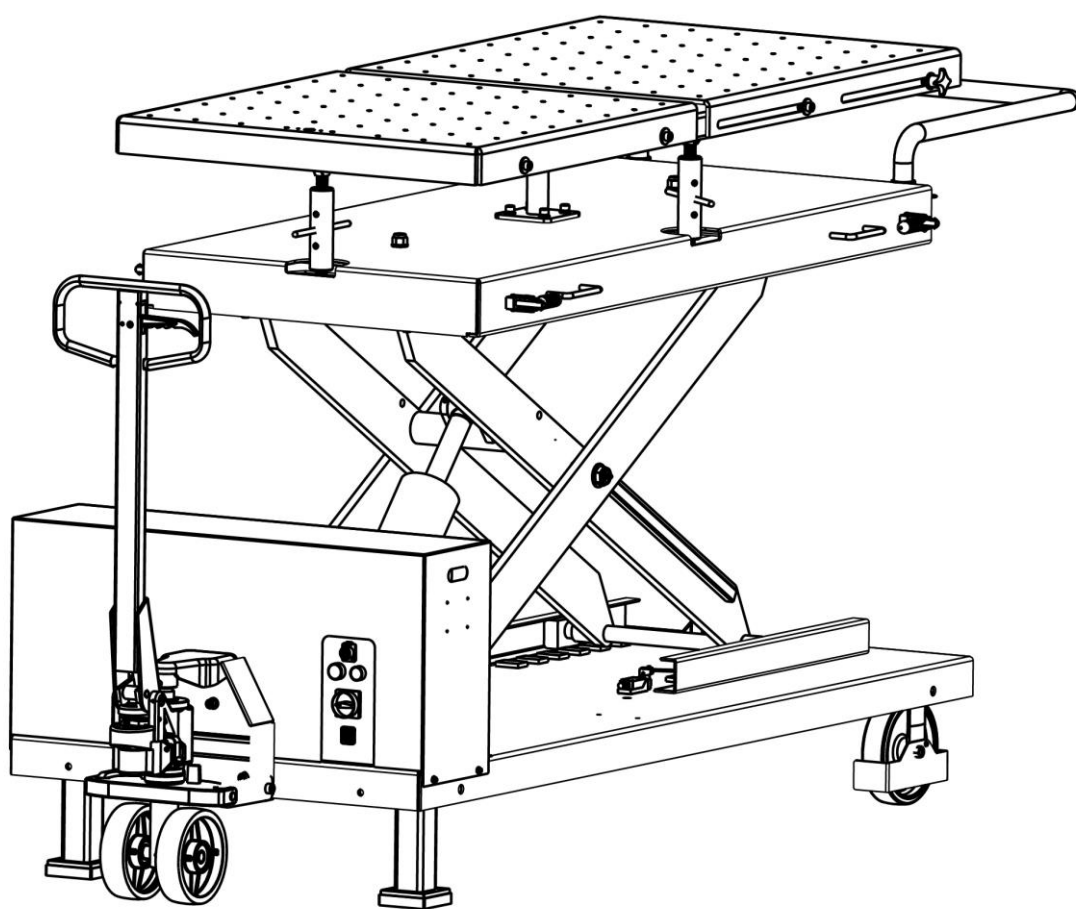

EAE



Distributed by

Please read this entire manual carefully and completely before installation or operation of the lift.

24/02/2021

www.eae-ae.com

IMPORTANT NOTES

Before start up, connecting and operating EAE products, it is absolutely essential that the operating instructions/owner's manual and, in particular the safety instructions are studied carefully. By doing so you can eliminate any uncertainties in handling EAE products and thus associated safety risks up front; something which is in the interest of you own safety and will ultimately help avoid damage to the device, When an EAE product is handed over to another person, not only the operating instructions but also the safety instructions and information on its designated use must be handed over to the person.

By using the product you agree the following conditions:

Copy right

The enclosed instructions are the property of EAE or its supplier, and are protected against duplication and reproduction by copyright laws, international agreements, and other domestic legislation. The reproduction or disclosure of instructions or an extract thereof is prohibited and offenders are liable to prosecution; EAE reserves the right or initiates criminal proceedings and asserts claims for damages in the event of infringements.

Warranty

The use of non-approved hardware will result in a modification of our products and thus to the exclusion of any liability or warranty, even if such hardware has been removed again in the interim.

It is not permissible to make any changes to our products and these are not only to be used together with genuine accessories and genuine replacement parts. Otherwise any warranty claims will be invalid.

Liability

The liability of EAE is limit to the amount that the customer has actually paid for this product. This exclusion of liability does not apply to damages caused through willful misconduct or gross negligence on the part of EAE.

All information in this manual is believed to be correct at time of publication.

EAE reserves the right to amend and alter technical data and composition without prior notice.

Please confirm at time of ordering.

| | |
|--|-----------|
| IMPORTANT NOTES | 2 |
| SAFETY NOTES | 4 |
| 1.1 Operation of the lifting table | 4 |
| 1.2 Checking of the lifting platforms | 4 |
| 1.3 Important safety notices | 4 |
| 1.4 Noise | 5 |
| 1.5 Warning labels | 6 |
| PACKING, STORAGE AND TRANSPORTATION | 7 |
| 2.1 The lift was packed as whole for transportation | 7 |
| 2.2 Storage | 7 |
| 2.3 Lifting and handling | 7 |
| PRODUCT DESCRIPTIONS | 8 |
| 3.1 General descriptions | 8 |
| 3.2 Construction of the lift | 8 |
| 3.3 Technical data | 8 |
| 3.4 Dimensions | 9 |
| COMMISON | 10 |
| 4.1 Jack installation | 10 |
| 4.2 Fill the oil reservoir with hydraulic oil | 11 |
| 4.3 Safety instructions | 11 |
| 4.4 Control button descriptions | 12 |
| 4.5 Use the pallet jack | 12 |
| 4.6 Use the lifting platform | 12 |
| TROUBLE SHOOTING | 13 |
| MAINTENANCE | 14 |
| Annex 1, Electrical diagrams and parts list | 15 |
| Annex 2, Hydraulic diagrams and parts list | 18 |
| Annex 3, Exploded mechanical drawings and parts list | 21 |

SAFETY NOTES

1.1 Operation of the lifting table

This mobile lifting table is designed for dismantling and fixing batteries of electric vehicles as well as engine, gearbox, drive axle, fuel tank, suspension, bracket and chassis components of traditional vehicles. Users are not allowed to use it for any other purposes. The applicable national regulations, laws and directives must be observed.

Only users aged 18 or above who have been instructed on how to operate the lifting table and have proven their ability to do so to the owner are to be entrusted with unsupervised operation of the lifting table. The task of operating the lifting table must be granted in writing.

Before loading onto the lifting table, users should study the original operation instructions and familiarize themselves with the operating procedures in several trial runs.

Lift within the rated load. Don't attempt to raise with excessive weight.

1.2 Checking of the lifting platforms

Checks are to be based on the following directives and regulations:

- Basic principles for testing lifting tables
- The basic health and safety requirements
- Harmonized European standards
- The applicable accident prevention regulations

The checks are to be organized by the user. The user is responsible for appointing an expert or qualified person to perform checking. It must be ensured that the person chosen satisfies the requirements.

The user bears special responsibility if employees of the company are appointed as experts or qualified persons.

1.3 Important safety notices

1.3.1 Recommend for indoor use only. DO not expose the lift to rain, snow or excessive moisture.

1.3.2 Only use this lift where the altitude is within 1000 meters and where the foundation is stable and capable of sustaining the load. Do not use on any asphalt surface.

1.3.3 Read and understand all safety warnings before operating the lift.

1.3.4 Keep hands and feet away from any moving parts. Keep feet clear of the lift when lowering.

1.3.5 Only these properly trained personnel can operate the lift.

1.3.6 Do not wear unfit clothes such as large clothes with flounces, ties, etc., which could be caught by moving parts of the lift.

1.3.7 To prevent evitable incidents, surrounding areas of the lift must be tidy and with nothing unsecured.

1.3.8 Lift within the rated capacity.

1.3.9 Lower the lift to its lowest position and do remember to turn off the power when service finishes.

1.3.10 Do not modify without manufacturer's advice.

1.3.11 If the lift is going to be left unused for a long time, users are required to:

- a. Disconnect the power;
- b. Empty the oil tank;
- c. Lubricate the moving parts with hydraulic oil.

WARNING: The warnings, cautions and instructions discussed in this instruction manual cannot cover all possible conditions and situations that may occur. It must be understood by the operator that common sense and caution are factors which cannot be built into this product, but must be supplied by the operator.































1.4 Noise

The noise during normal working is less than 70 dB(A)

1.5 Warning labels

All safety warning labels are clearly depicted on the lift to ensure that the operator is aware of and avoid the dangers of using the lift in an incorrect manner. The labels must be kept clean and they have to be replaced if detached or damaged. Please read carefully the meaning of each label and memorize them for future operation.

DON NOT ENTER UNDER THIS PLATFORM UNLESS IT IS MECHANICALLY LOCKED

| | | |
|---|---|---|
|  CAUTION |  CAUTION |  CAUTION |
|  <p>Read and digest the complete operation instructions before operating the lifting table.</p> |  <p>Prior to move the table the load platform must have been lowered fully.</p> |  <p>Use only when the lifting table is in a static position. Lock the casters when necessary.</p> |
|  CAUTION |  CAUTION |  CAUTION |
|  <p>Before raising operation, run the lifting table without load for a complete cycle to ensure it is in good condition.</p> |  <p>Ensure the load is centered over the carrying table.</p> |  <p>The space under or around load carrying table shall be free of obstructions before use.</p> |
|  CAUTION |  CAUTION |  CAUTION |
|  <p>The load carrying table shall be observed by the operator throughout the motion of the table.</p> |  <p>Avoid excessive rocking the lifted load or the carrying table.</p> |  <p>In case of trouble or disruption, turn off the main switch and make sure it cannot be switched on again unintentionally. Inform the supervisor.</p> |
|  WARNING |  DANGER | The instructions, cautions and warnings written above as well as in the in Manual cannot cover all possible conditions and situations that may occur. The Common sense for safety must be always in the mind of the operator. For damages caused through willful misconduct or gross negligence, the manufacturer or its distributors are excluded of liability. |
|  <p>Don't use on a slope of greater than 2.5 %.</p> |  <p>Load within the maximum load capability. Do not attempt to lift goods with excessive length or width.</p> | |
|  WARNING |  DANGER | |
|  <p>Don't use outdoor in strong breeze with the wind speed being more than 14 m/s.</p> |  <p>Keep hands, feet and other parts of the body away from the moving parts to avoid pinching or shearing.</p> | |
|  WARNING |  DANGER | |
|  <p>It is for carrying goods only. Travelling on the load carrying platform is forbidden.</p> |  <p>Never try to remove, interrupt or modify the safety related components or devices.</p> | |

PACKING, STORAGE AND TRANSPORTATION

Packing, lifting, handling, transporting operations must be performed only by experienced personnel with appropriate knowledge of the lift and after reading this manual.

2.1 The lift was packed as whole for transportation

| Item | Packed by | Dimension | Weight(kg) | Quantity |
|----------------------------|------------------------|----------------------------|------------|----------|
| MS12M mobile lifting table | Steel frame and carton | 2230*1020*730mm | 767 kg | 1 |
| | | 87 13/16"x40 3/16"x28 3/4" | 1689 lbs. | |

2.2 Storage

The packs must be kept in a covered and protected area in a temperature range of -10°C to +40°C. They must not be exposed to direct sunlight, rain or water.

Stacking the packs

We advise against stacking because the packs are not designed for this type of storage. The narrow base, heavy weight and large size of the packs make stacking difficult and potentially dangerous.

If stacking is unavoidable, use all appropriate precautions:

-never stack more than 2 meters in height.

-never make stacks of single packs. Always stack pairs of packs in a cross pattern so that the base is bigger and the resulting stack is more stable. Once the stack is complete, restrain it using straps, ropes or other suitable methods.

A maximum of three packs can be stacked on lorries, in containers, and in railway wagons, on condition that the packs are strapped together and restrained to stop them falling.

2.3 Lifting and handling

The packs can be lifted and transported only by using lift trucks.

Opening the packs

When the lift is delivered, make sure that it has not been damaged during transportation and that all the parts are present.

Packs must be opened adopting all the precautions required to avoid injury to persons (keep at a safe distance when cutting the straps) or damage to parts of the machine (be careful that no parts are dropped while you are opening the **packs**)

PRODUCT DESCRIPTIONS

3.1 General descriptions

This mobile lifting table is designed for dismantling and fixing batteries of electric vehicles as well as engine, gearbox, drive axle, fuel tank, suspension, bracket and chassis components of traditional vehicles. The mobile and compact structure make it easily enter into the service space. With a maximum lifting capacity of 1200kg and reserved holes (100mm*100mm) on the working table for positioning and fixing components with specialized fixtures.

The suspend platform can tilt within a height of 30mm.

Hydraulic driven with mechanical safety locking protection.

3.2 Construction of the lift

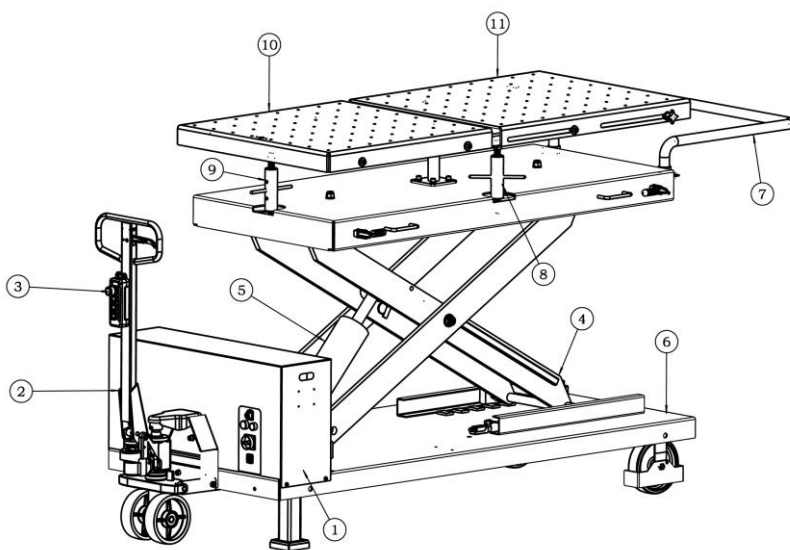

1. Power unit
2. Mobile jack
3. Hand-held control unit
4. Support arm
5. Hydarulic cylinder
6. Base frame
7. Hand-held bar
8. Side-tilt adjusting device
9. Front-tilt adjusting device
10. Fixed side of suspended platform
11. Extendable side of suspended platform

3.3 Technical data

| | |
|--|--|
| Model | EE-MS12M |
| Rated capacity | 1200kg/2700 lbs. |
| Motor | 1.5kW |
| Voltage | 220V-1Ph-50HZ 230V-1Ph-50Hz 110V-1Ph-60Hz 220V-1Ph-60Hz |
| Full rise time with rated load (normal speed) | Approx.45s |
| Full rise time with rated load (slower speed) | Approx.170s |
| Full descent time with rated load | Approx.40s |
| Hydraulic pressure | Approx.16 MPa /2300 psi |
| Oil reservoir | 4L / 4.2quarts |

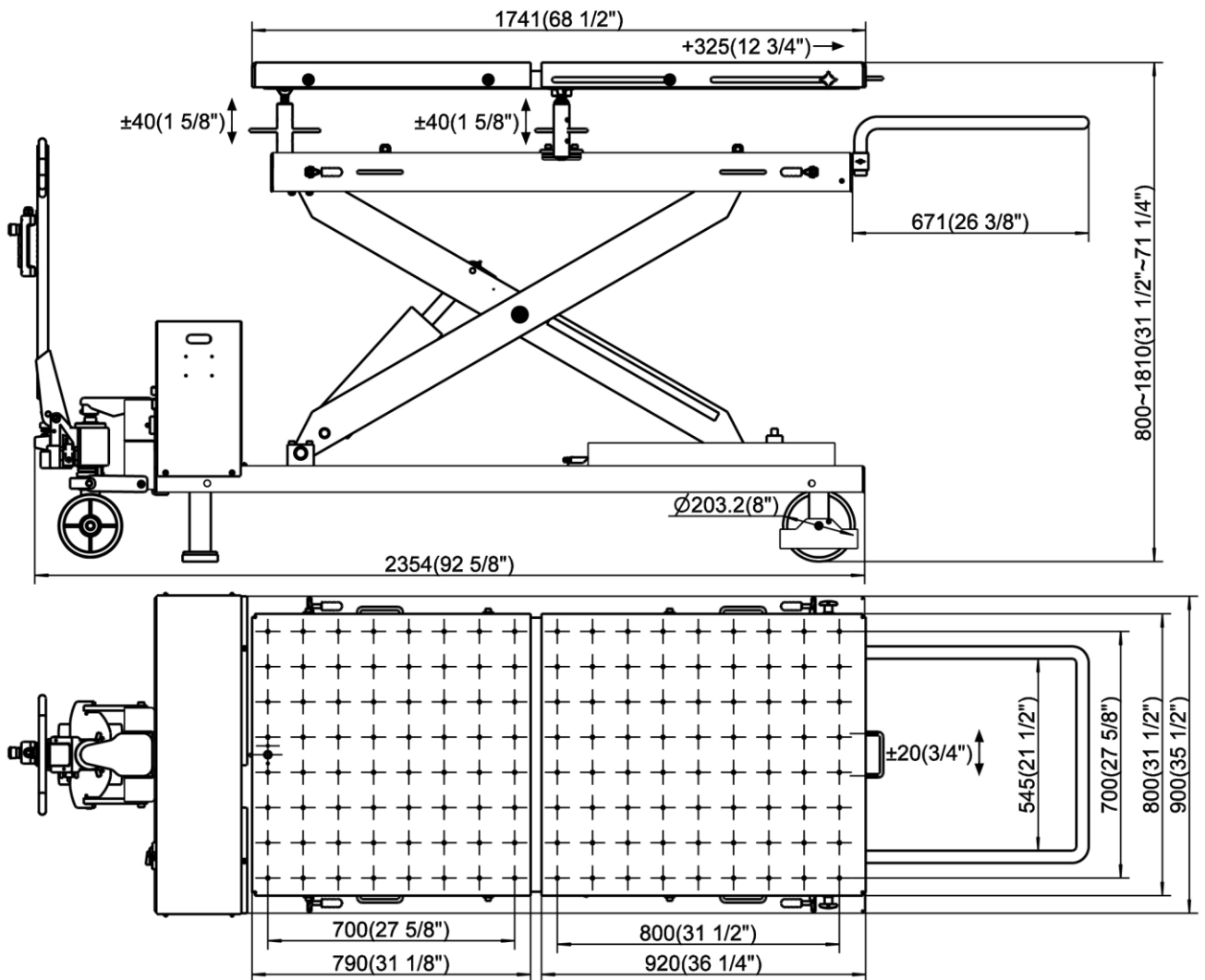
3.4 Dimensions

COMMISON

Only authorized persons are allowed to operate the lifting table.

Read and digest the complete operation instructions before operating the lifting table.

4.1 Jack installation

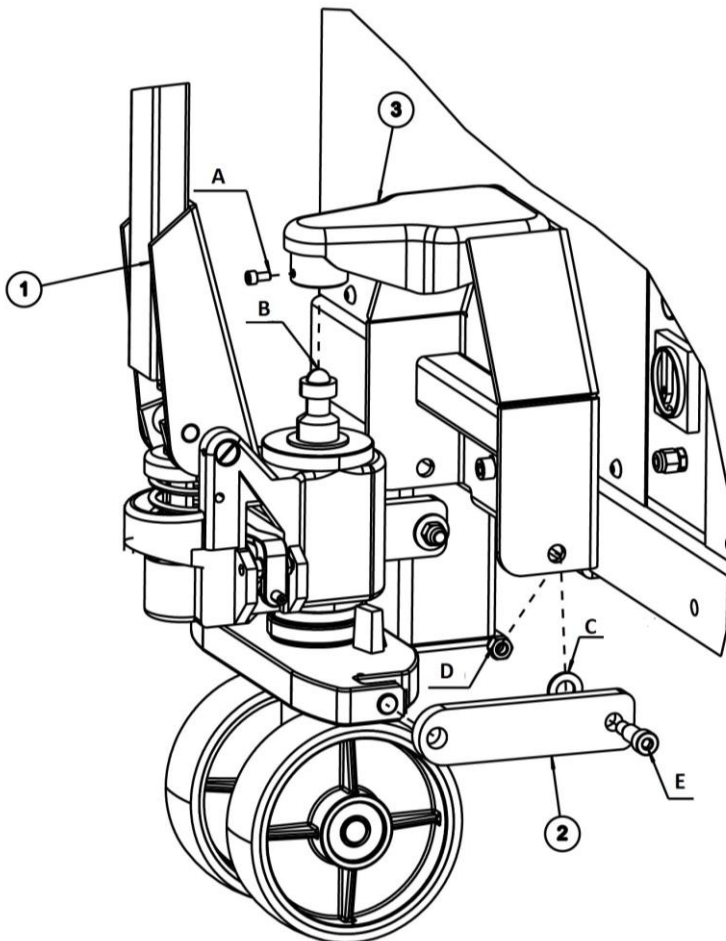

A : hex socket cylinder head screw M6x12
B: steel ball
C: flat washer D14
D: locking nut M10
E: hex socket botton head screw M10x25

Installation steps :

1. Put steel ball B into position as indicated in the scheme.
2. Untighten screw A attached with component 3.
3. Insert ball B into component 3.
4. Connect component 3 and component 2 as indicated by the scheme.
5. Tighten the screw A.

4.2 Fill the oil reservoir with hydraulic oil

ONLY CLEAN AND FRESH OIL ONLY

Lift must be fully lowered before changing or adding hydraulic oil.

Fill about 3 liters (3.2 quarts) into the oil tank to run the lift up and down for 2 or 3 cycles.

It is suggested to use HM NO.46 hydraulic oil when average temperature of the location is above 18 degree Celsius and using HM NO.32 hydraulic oil when temperature is below 10 degree Celsius. Change the oil 6 months after initial use and once per year thereafter.

4.3 Safety instructions

Use the lift after carefully reading the instruction manual and understand the contents for safe and proper use.

4.3.1 Before commissioning

- This lifting table is only designed for loading batteries and engine, gearbox, drive axle, fuel tank, suspension, bracket and chassis components. Do not use for any other purpose.
- Don't use on a slope of greater than 2.5 %.
- Don't use outdoor in strong breeze with the wind speed being more than 14 m/s.
- Lower the pallet jack and use only when the lifting table is in a static position.
- Prior to move the lifting table, its load platform must have been lowered fully.
- Before loading operation, run the lifting table without load for a complete cycle to ensure it is in good condition.
- Do not use the lifting table whenever any of the safety devices are not operating properly.
- The space under or around load carrying table shall be free of obstructions before use.
- Check and remove oil or foreign materials on the lifting platform.
- Check if the safety lock device is working properly before operation.

4.3.2 During commissioning

- The load shall be centered and well fixed on the carrying table.
- Do not attempt to raise or lower whatever loads that exceed the rated capacity.
- Only raise and lower after verifying that load is properly positioned or fixed.
- Travelling on the load carrying platform is forbidden
- The load carrying table shall be observed by the operator throughout the motion of the lift table.
- Do not shack the load during raising or lowering the lifting table. If the load is tilting to one side, stop the motion of the lift immediately.
- Keep hands, feet and other parts of the body away from the moving parts to avoid pinching or shearing.
- Prohibit unauthorized persons from accessing the lifting table.
- When lowering lifting table, make sure nothing will interfere with its descent.

4.3.2 Others

- This lifting table is not designed to be waterproof. Do not use it in environment with excessive moisture.
- Do not use this lifting table in explosive environment.
- Only move the lifting table when it is completely lowered.
- When the lifting table is not in use, lower it completely.
- Prohibit unauthorized persons from using the lifting table.
- Do not change or modify without permission. Otherwise the lift may not operate properly, or a serious accident may occur.
- If you find a problem with the lifting table during use or inspection, stop using it and request maintenance. Do not use until it is repaired.
- Use the lifting table after reading the instruction manual carefully and understand the contents of them for safe and proper use.

4.4 Control button descriptions

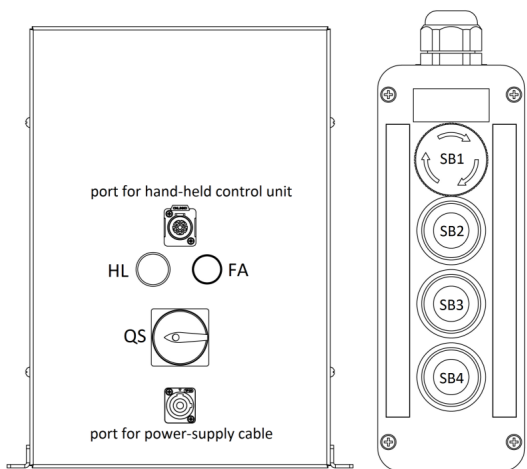

| CODE | Description | Function |
|------|-----------------|---|
| QS | Main switch | Turn on or off the main power supply |
| HL | Power indicator | Display if power supply is connected |
| SB1 | Stop button | Turn off the hand-held control |
| SB2 | UP button | Push to rise slowly |
| SB3 | UP button | Push to rise normally |
| SB4 | DOWN button | Control the lowering movement |
| FA | Buzzer | Audible warning for overloading and descent |

In case of overloading at raised position, it shall not possible for the platform to start from the rest. The load exceeded has to be removed in order to restore to normal working state.

4.5 Use the pallet jack

Prior to move the table, the load platform must have been lowered fully.

The pallet jack is used to move the lift by lifting its base off the floor.

Always descend the base onto the floor before raising.

The pallet jack is operated by a hand grip and a lever inside the grip.

Push down the LEVER and move up and down the hand grip to raise the base frame of the lift.

Keep the LEVER at neutral position when moving the lift .

Pull up the LEVER to descend the base frame of the lift.

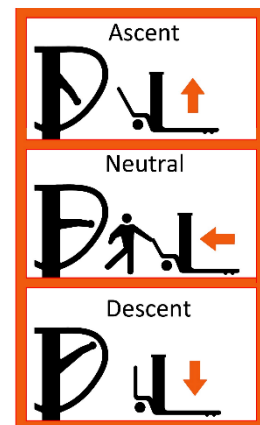

4.6 Use the lifting platform

Before loading operation, run the lifting table without load for a complete cycle to ensure it is in good condition.

Get familiar with lift controls by running the lift without load through a few cycles.

The load carrying table shall be observed by the operator throughout the motion of the lift table.

Do not try to move the lifting table when its platform is raised with load. ONLY move when the lifting table is completely lowered

Ascend

Ensure the load is centered over the carrying table.

1. Make sure that you have read and understood the operation manual before operation.
2. Push the lifting table under the load to be lifted. Lower the mobile pallet jack.
3. Push the UP button until expected height.
4. Turn off the power switch before starting service work.

Descend

When lowering the lift pay careful attention that all personnel and objects are kept clear.

1. Push the UP button to disengage the mechanical locking unit.
2. Push the DOWN button until lower to expected height. Turn off the power switch.

TROUBLE SHOOTING

ATTENTION: If the trouble could not be fixed by yourself, please do not hesitate to contact us for help .We will offer our service at the earliest time we can. By the way, your troubles will be judged and solved much faster if you could provide us more details or pictures of the trouble.

| TROUBLES | POSSIBLE CAUSES | SOLUTIONS |
|--|---|-----------------------------------|
| Motor does not run and will not raise. | Loose wire connection | Check and make a good connection. |
| | Burnt motor. | Replace it. |
| Motor runs but will not raise. | Relief valve is not well screwed up or jammed. | Clean or make adjustment |
| | Damaged gear pump. | Replace it. |
| | Too low oil level. | Add oil. |
| | The hose connection is loose. | Tighten it. |
| | The cushion valve is not well screwed up or jammed. | Clean or make adjustment |
| The table goes down slowly after being raised. | The oil hose leaks. | Check or replace it. |
| | Untightened oil cylinder. | Replace the seal. |
| | The non-return valve leaks. | Clean or replace it. |
| | Solenoid unloading valve fails to work well. | Clean or replace it. |
| | Unloading valve leaks. | Check and adjust the tightness. |
| Raising too slow. | Jammed oil filter | Clean or replace it. |
| | Too low oil level. | Add oil. |
| | The relief valve is not adjusted to the right position. | Make adjustment. |
| | Too hot hydraulic oil (above 45°) . | Change the oil. |
| | Abraded seal of the cylinder | Replace the seal. |
| Lowering too slowly. | Jammed singe way throttle valve | Clean or replace it. |
| | Dirty hydraulic oil | Clean or replace. |
| | Jammed oil hose | Clean it. |

MAINTENANCE

Easy and low cost routine maintenance can ensure the lift work normally and safely.

Following are requirements for routine maintenance.

1. Lubrication before first use

Lubricate the moving parts with NO.1 lithium grease. Regularly add grease for every 3 months.

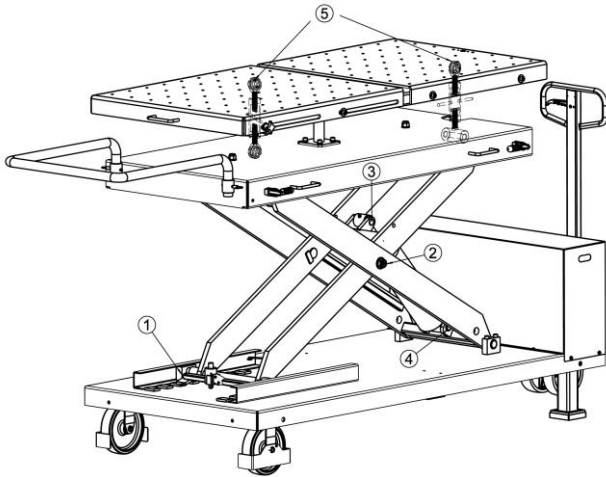

- ① Sliding blocks
- ② Middle shaft of the support arm
- ③ Upside shaft of the cylinder
- ④ Downside shaft of the cylinder
- ⑤ Threaded adjusting rod

2. Routine maintenance

| S/N | ITEM | METHODS | PERIOD |
|-----|---------------------------------------|--|-------------|
| 1 | Foot casters | Push and turn around the lifting cable to check the flexibility of the casters. | Every day |
| 2 | Surface of the load-carrying platform | Inspect and wipe off the oil and stains before use. | Every day |
| 3 | Control buttons | Check if control buttons work as "hold- to -run " and check if they work as the function indicated. | Every day |
| 4 | Mechanical safety catch | Check if it can engage and disengage by pushing control buttons. | Every day |
| 5 | Circlip | Inspect if any circlip goes off its groove. Make sure they are positioned in the grooves. | Every month |
| 6 | Sliding blocks and tracks | Push the UP and DOWN button to check if any slider is over-worn. Add grease to ensure smooth running. Change over-worn sliders. | Every month |
| 7 | Entire lifting platform | Run for several cycles with and without rated load. The table can run steadily and smoothly with no abnormal noise. | Every month |
| 8 | Hydraulic blocks | Inspect if the valves leak or not. Clean or change the valve if any leakage. | Every month |
| 9 | Oil hose and cylinder fitting | Inspect to ensure no leakage before using the lift. | Every month |
| 10 | Hydraulic oil | Change the oil 6 months after initial use and once per year thereafter. Inspect the hydraulic oil and change the oil if the oil becomes black or there is dirt in the oil tank. It is advised to use HM NO.46 hydraulic oil. | Every year |

If users stick to the above maintenance requirements, the lift will always keep a good working condition and its service life could be extended.

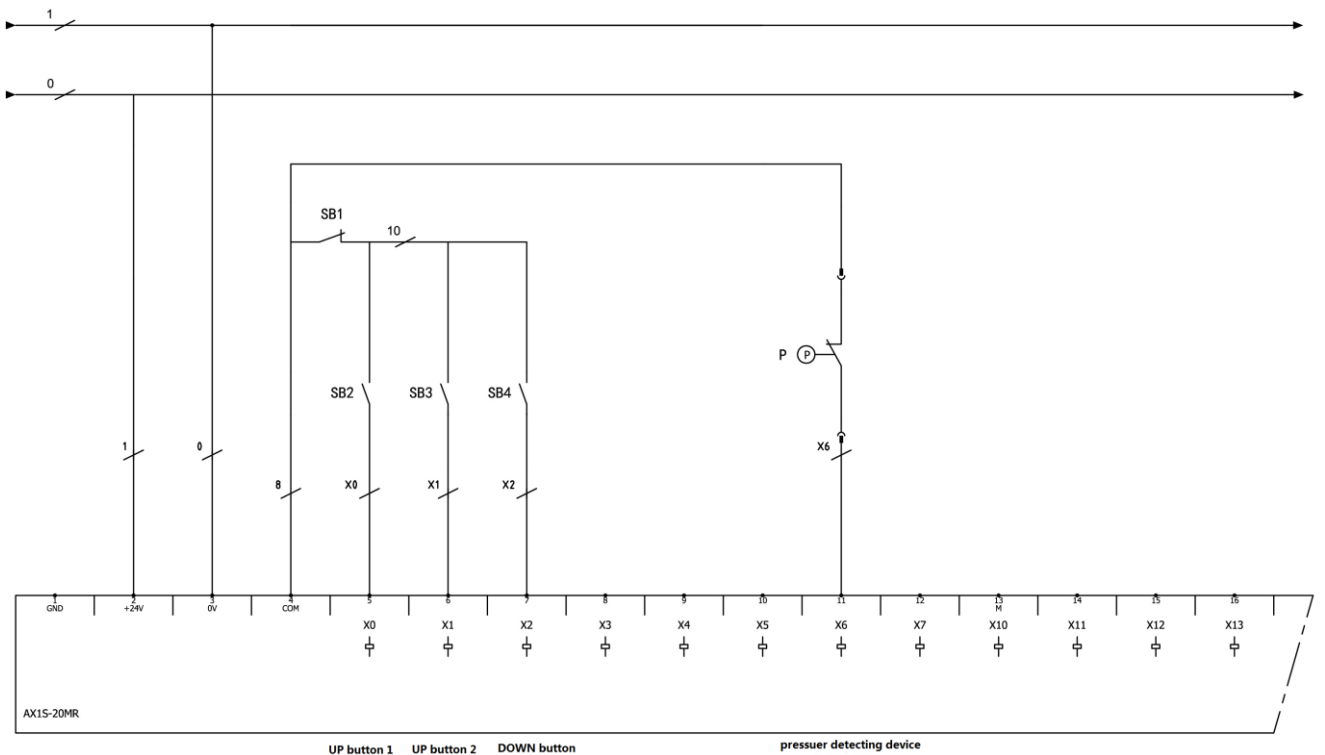
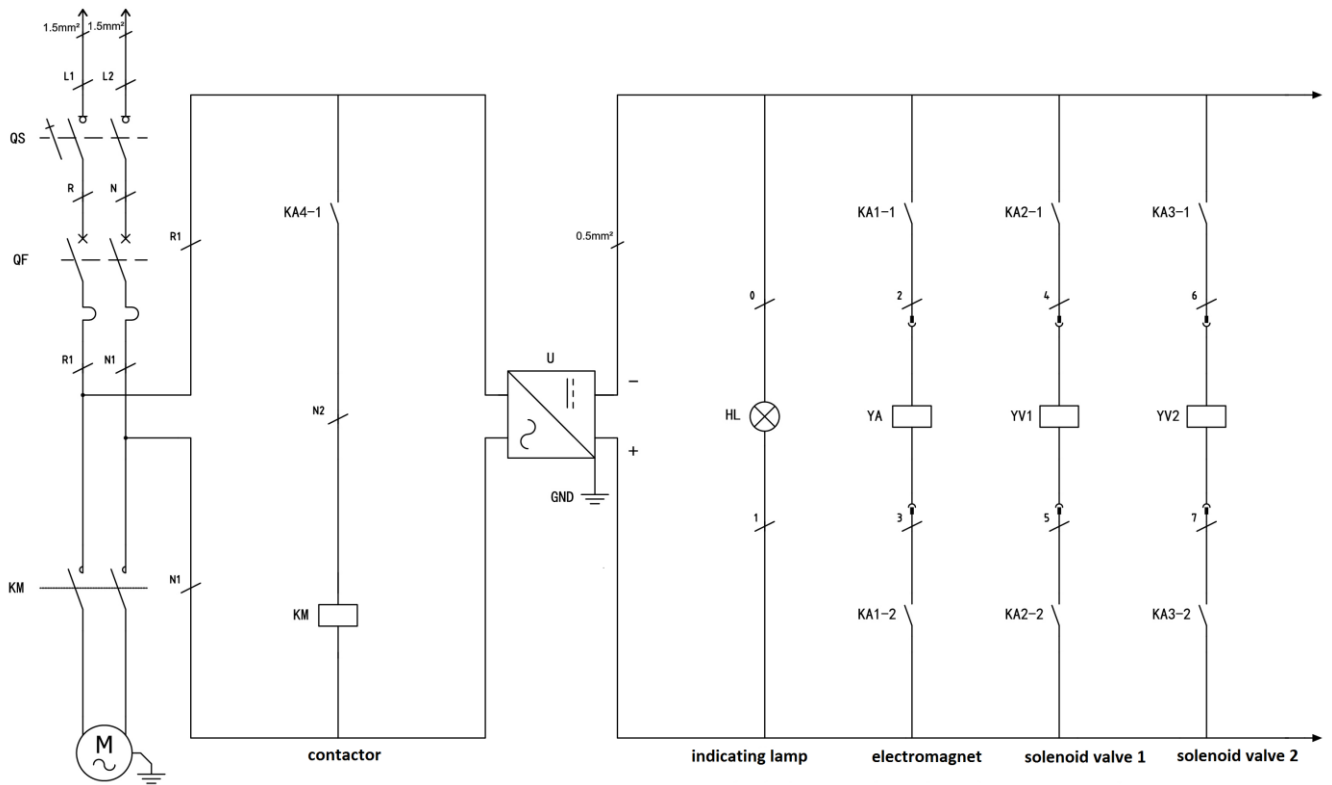
Annex 1, Electrical diagrams and parts list

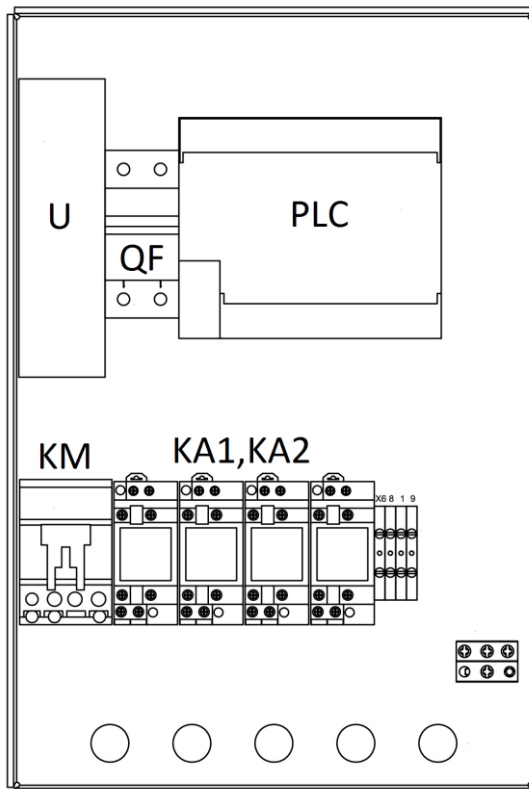
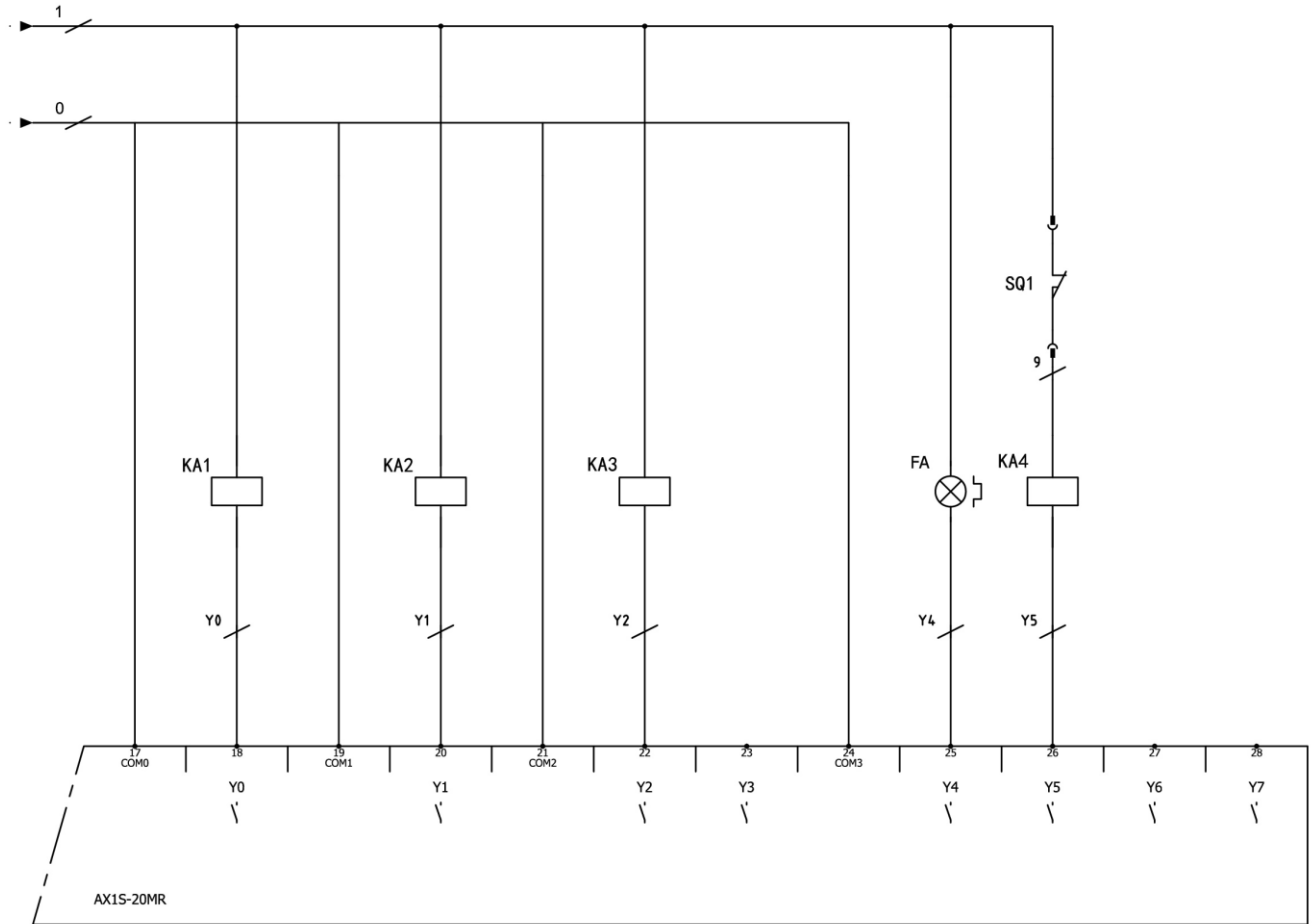

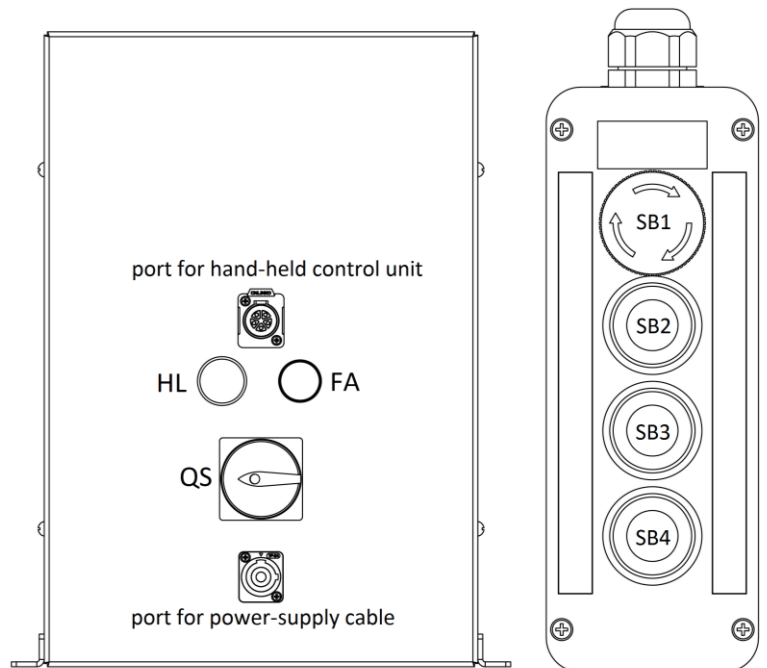

| S/N | Component Code | P-code | Descriptions | Specification | Qty |
|-----|-----------------|-----------|-------------------------------|---------------------------------------|-----|
| 1 | SB1,SB2,SB3,SB4 | 320307035 | Hand-held control | COP-4B | 1 |
| 2 | U | 321103413 | Switching power supply | EDR-150W/AC100V-240V/DC24V | 1 |
| 3 | PLC | 321301022 | PLC | AX1S-20MT-D | 1 |
| 4 | KM | 320901029 | AC contactor 110V (60Hz) | CJX2-1810/AC110V (60HZ) | 1 |
| | | 320902004 | AC contactor 220V/230V (50Hz) | CJX2-1810-AC220V | 1 |
| 5 | SQ1 | 320301011 | Limit switch | TZ8108 | 1 |
| 6 | QF | 320802001 | Circuit breaker | DZ47-63C32/2P(NXB-63C32/2P) | 1 |
| 7 | QS | 320307036 | Power switch | LW26-20GS/04-1 (48mm*48mm) | 1 |
| 8 | HL | 321201001 | Indicating lamp | AD17-22G-AC/DC24(RDD6-22D/31-AC/DC24) | 1 |
| 9 | - | 320503002 | Earth terminal | 4 | 1 |
| 10 | - | 320505006 | Wire terminal | VK-5N(UK-5N) | 4 |
| 11 | FA | 321202001 | Alarm buzzer | AD17-22SM/AC/DC24(RDD16-22SM/AC/DC24) | 1 |
| 12 | QF1 | 320802001 | Circuit breaker | CDB6iC32/2P (CB-60A C32) | 1 |
| 13 | YA | 330310018 | Electromagnet | DCT45*20 | 1 |
| 14 | KA1,KA2 | 320601005 | Relay | HH62P-L/DC24V-10A | 4 |
| 15 | - | 320601009 | Relay holder | PTF-08A-E | 4 |

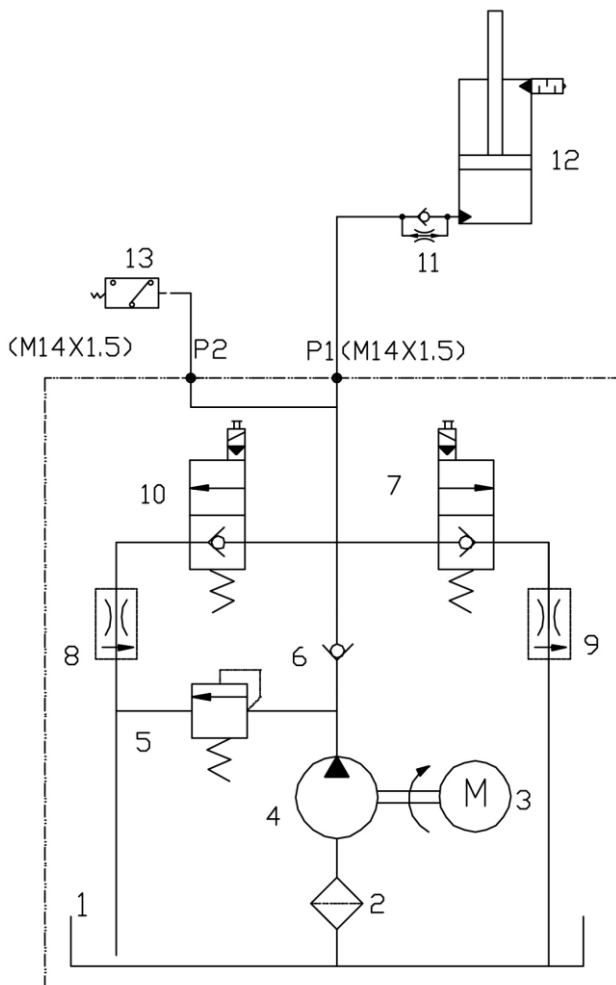
Annex 2, Hydraulic diagrams and parts list

- 1 Steel reservoir
- 2 Filter
- 3 Motor
- 4 Gear pump
- 5 Relief valve
- 6 Non-return valve
- 7 Spool of the solenoid valve
- 8 Pressure make-up valve
- 9 Spool of the solenoid valve
- 10 Pressure make-up valve
- 11 Cylinder connector
(restrictive valve included)
- 12 Cylinder
- 13 Pressure detecting sensor

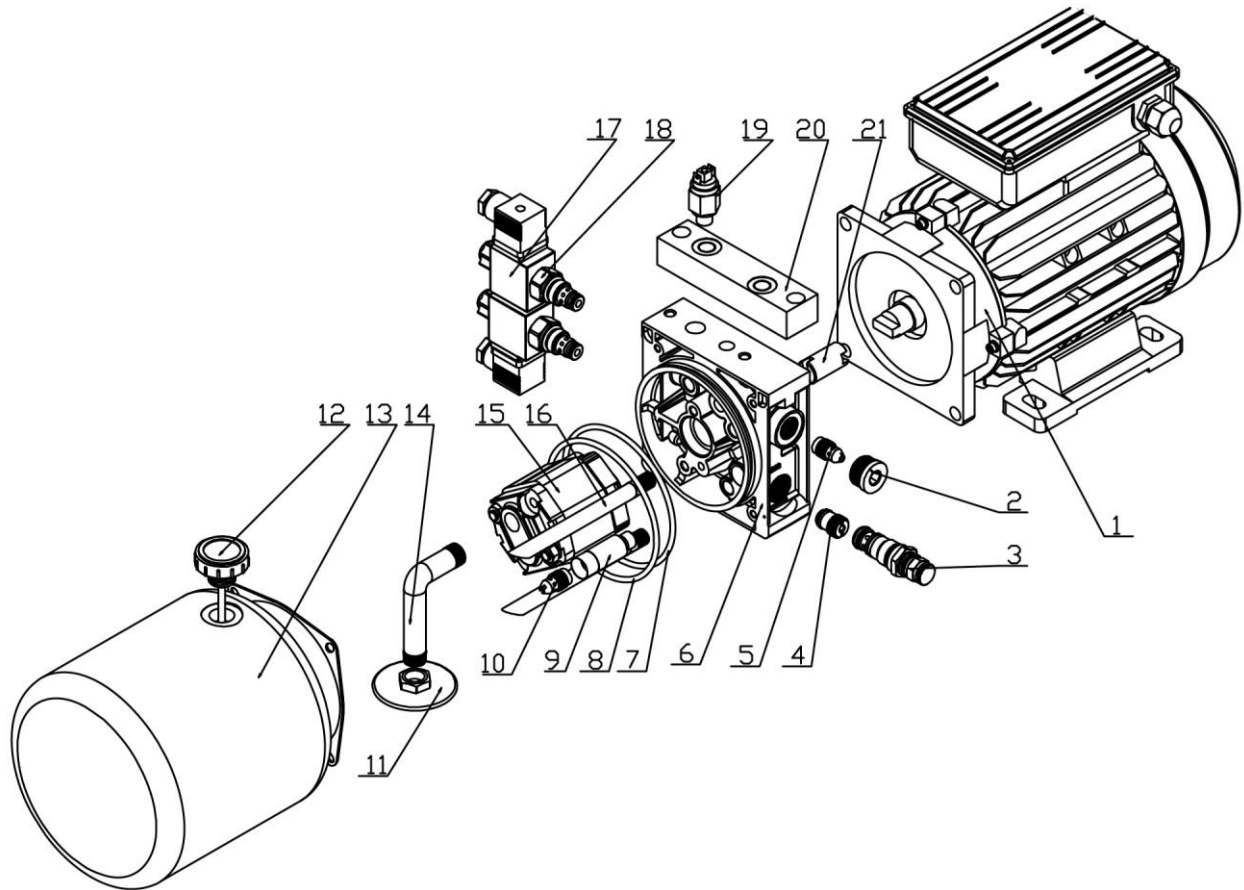

| Pos. | P-code | Descriptions | Specification | Qty |
|------|-----------|-------------------------------------|------------------|-----|
| 1 | 320204207 | Motor (230V-1Ph-50Hz) | ML230150-4F-50HZ | 1 |
| | 320204211 | Motor (220V-1Ph-50Hz) | ML220150-4F-50HZ | 1 |
| | 320204212 | Motor (110V-1Ph-60Hz) | ML110150-4F-60HZ | 1 |
| | 320204213 | Motor (220V-1Ph-60Hz) | ML220150-4F-60HZ | 1 |
| 2 | 330503020 | Steel fitting | SP-06 | 1 |
| 3 | 330304011 | Relief valve | RV03 | 1 |
| 4 | 330302011 | Non-return valve | CV-02A | 2 |
| 5 | 330503024 | Pressure make-up valve | RPCV-02-02 | 2 |
| 6 | 330105008 | Hydraulic block | C010 | 1 |
| 7 | 207101102 | Type O seal ring | 115*2 | 1 |
| 8 | 207101101 | Type O seal ring | 112*4 | 1 |
| 9 | 330600004 | Connector of pressure make-up valve | GJT-G3/8-Z3/8 | 1 |
| 10 | 330503025 | Pressure make-up valve | RPCV-02-01 | 2 |
| 11 | 330403008 | Filter | FS-03B | 1 |
| 12 | 330405055 | Cover | FC-04N | 1 |
| 13 | 330405054 | Oil reservoir | 4L-TS058-33-H | 1 |
| 14 | 330401015 | Oil-sucking pipe | FP-03H-4676 | 1 |
| 15 | 330201901 | Gear pump | CBKL-G2200 | 1 |

| Pos. | P-code | Descriptions | Specification | Qty |
|------|-----------|-----------------------------|---------------|-----|
| 16 | 330402008 | Oil-return pipe | RU12-150 | 1 |
| 17 | 330311007 | Solenoid coil | FC024DC | 1 |
| 18 | 330311006 | Spool of the solenoid valve | SCV | 1 |
| 19 | 320306024 | Pressure sensor | 40V10H17 | 1 |
| 20 | 330105009 | Transition block | MR10-02-02 | 1 |
| 21 | 330404008 | Coupling | ACP-365 | 1 |

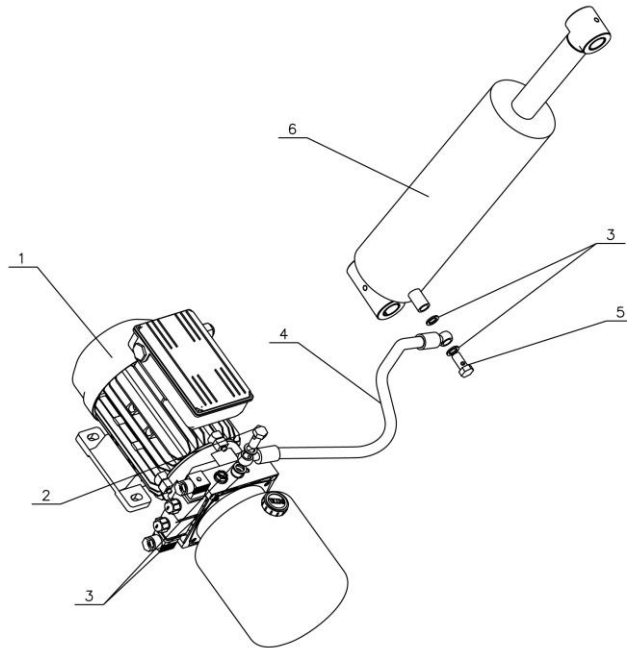

| Pos. | P-code | Descriptions | Specification | Qty |
|------|-----------|--|------------------|-----|
| 1 | 320204207 | Motor (230V-1Ph-50Hz) | ML230150-4F-50HZ | 1 |
| | 320204211 | Motor (220V-1Ph-50Hz) | ML220150-4F-50HZ | 1 |
| | 320204212 | Motor (110V-1Ph-60Hz) | ML110150-4F-60HZ | 1 |
| | 320204213 | Motor (220V-1Ph-60Hz) | ML220150-4F-60HZ | 1 |
| 2 | 410281130 | Cylinder connector | CJ-A12-B5-C10 | 1 |
| 3 | 207103025 | Bonded washer | 13_7X20X1_5 | 1 |
| 4 | 624002128 | Oil hose | L=800 | 4 |
| 5 | 310102038 | Cylinder connector (restrictive valve included) | MLH600-A1-B1 | 1 |
| 6 | 615062206 | Cylinder | YG100/117-40-280 | 1 |

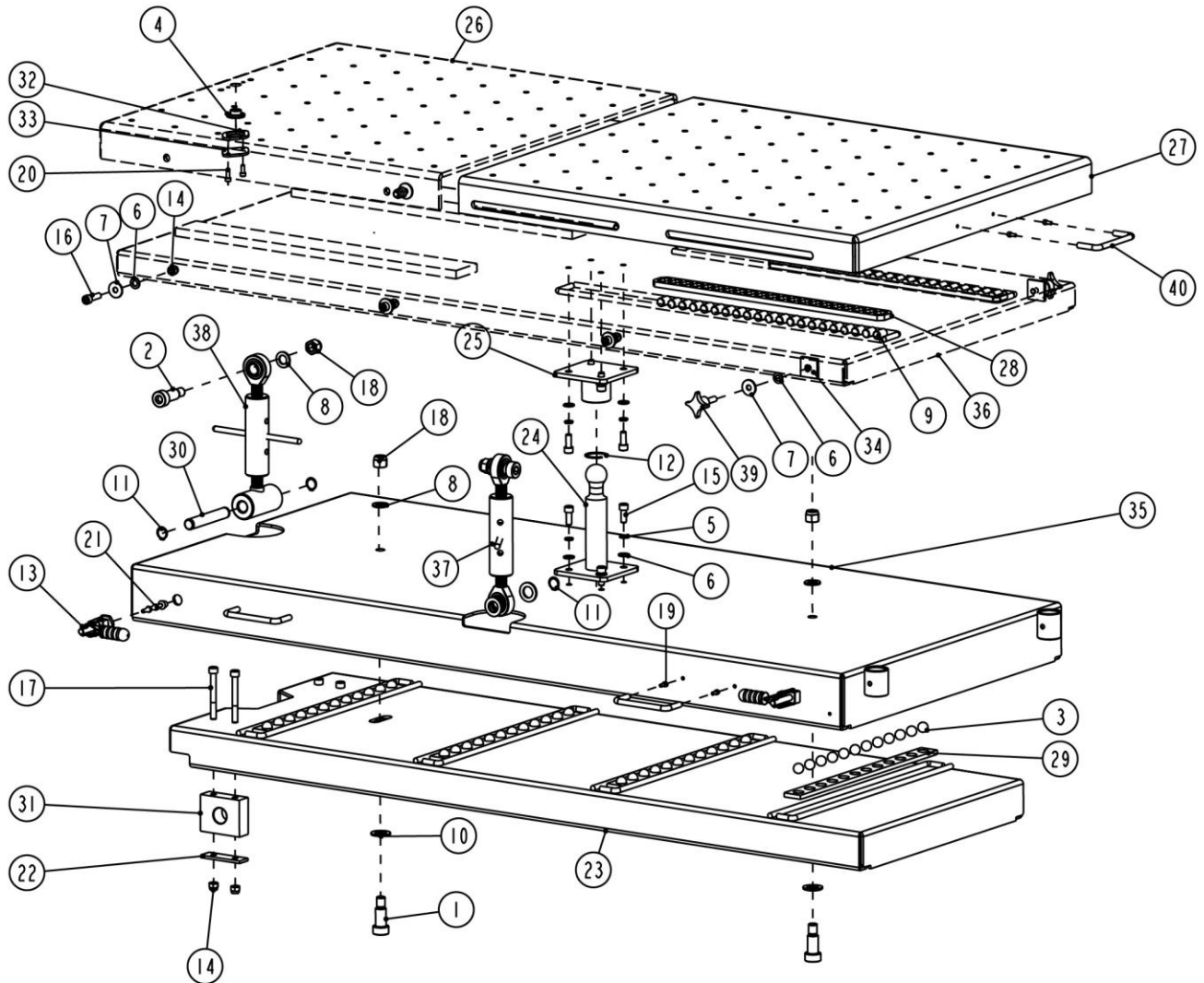
Annex 3, Exploded mechanical drawings and parts list

| POS. | Code | Descriptions | Specification | Qty |
|------|-----------|--|------------------|-----|
| 1 | 202208008 | Hex socket cylinder head screw (with shaft shoulder) | 20-M16X35-GB5281 | 2 |
| 2 | 202208009 | Hex socket cylinder head screw (with shaft shoulder) | 20-M16X40-GB5281 | 2 |
| 3 | 420270280 | Rolling ball | 6435B-A21 | 48 |
| 4 | 208107015 | Levelling bubble scale | BFHD-3412 | 1 |
| 5 | 204101006 | Flat washer | D10-GB93 | 8 |
| 6 | 204101006 | Flat washer | D10-GB95 | 16 |
| 7 | 201104001 | Large washer | D10-GB96 | 8 |
| 8 | 204101009 | Flat washer | D16-GB95 | 4 |
| 9 | 206101014 | Cylindrical pin | D16X25-GB119_2 | 42 |
| 10 | 204101011 | Flat washer | D20-GB95 | 4 |
| 11 | 204301007 | Circlip | D20-GB894_2 | 3 |
| 12 | 204301205 | Circlip | D40-GB893_1 | 1 |
| 13 | 208109022 | Quick clamp | GH-36204M | 4 |
| 14 | 203103007 | Hex locking screw | M10-GB889_1 | 10 |

| POS. | Code | Descriptions | Specification | Qty |
|------|------------|--|---------------|-----|
| 15 | 202109042 | Hex socket cylinder head screw | M10X25-GB70_1 | 8 |
| 16 | 202109044 | Hex socket cylinder head screw | M10X35-GB70_1 | 6 |
| 17 | 202109142 | Hex socket cylinder head screw | M10X90-GB70_1 | 4 |
| 18 | 203103019 | Hex locking screw | M16-GB889 | 4 |
| 19 | 202109008 | Hex socket cylinder head screw | M5X12-GB70_1 | 10 |
| 20 | 202109020 | Hex socket cylinder head screw | M6X15-GB70_1 | 2 |
| 21 | 208109020 | Rubber pressing head | M8X75 | 4 |
| 22 | 410563111 | Padding plate | MS12AC-A2-B6 | 2 |
| 23 | 614059207 | Lower sider platform | MS12AC-A3-B1 | 1 |
| 24 | 614059209 | Cardan joint holder | MS12AC-A3-B3 | 1 |
| 25 | 614059210 | Cardan joint cap | MS12AC-A3-B4 | 1 |
| 26 | 410563303B | Fixed platform | MS12AC-A3-B6 | 1 |
| 27 | 410563313 | Platform extension | MS12AC-A3-B7 | 1 |
| 28 | 420560060B | Needle roller cage | MS12AC-A3-B8 | 2 |
| 29 | 420560070 | Ball roller holder | MS12AC-A3-B9 | 4 |
| 30 | 410562741 | Shaft | MS12AC-A3-B10 | 1 |
| 31 | 420560040 | Support holder | MS12AC-A3-B13 | 2 |
| 32 | 410563393 | lining plate | MS12AC-A3-B14 | 1 |
| 33 | 410563403 | Padding plate for levelling bubble scale | MS12AC-A3-B15 | 1 |
| 34 | 410901097 | Installation plate for hand-held bar | MS12AC-A3-B16 | 2 |
| 35 | 614901031 | Support platform | MS12M-A3-B2 | 1 |
| 36 | 614901032 | Tilting platform | MS12M-A3-B5 | 1 |
| 37 | 615068021 | Side-tilting assembly | MS12M-A3-B17 | 1 |
| 38 | 615068022 | Front-tilting assembly | MS12M-A3-B18 | 1 |
| 39 | 208109026 | Cross knob | NCRM10-35 | 2 |
| 40 | 208109019 | Stainless steel knob | US10-120 | 5 |

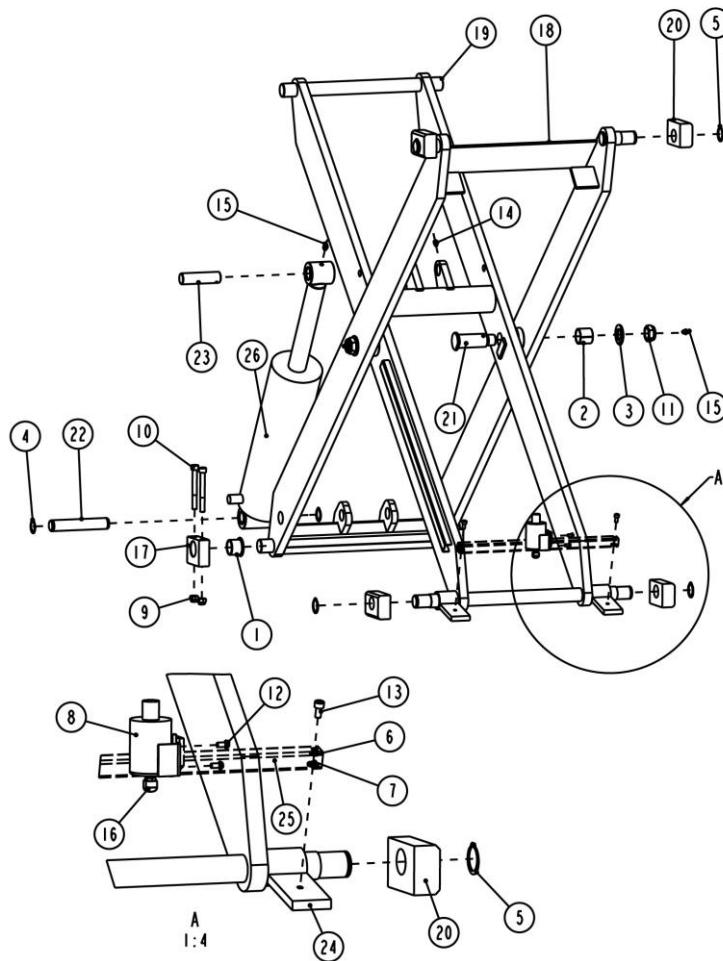

| POS. | Code | Descriptions | Specification | Qty |
|------|-----------|--------------------------------|----------------|-----|
| 1 | 205103004 | Flange bearing | 3026-SF-1F | 2 |
| 2 | 205101054 | Bearing | 3030-SF-2X | 2 |
| 3 | 204101012 | Flat washer | D24-GB95 | 2 |
| 4 | 204301009 | Circlip | D25-GB894_2 | 2 |
| 5 | 204301010 | Circlip | D28-GB894_2 | 4 |
| 6 | 204201003 | Spring washer | D6-GB93 | 2 |
| 7 | 204101004 | Flat washer | D6-GB95 | 2 |
| 8 | 330310018 | Electromagnet | DCT45X20 | 1 |
| 9 | 203103007 | Hex locking nut | M10-GB889_1 | 4 |
| 10 | 202109142 | Hex socket cylinder head screw | M10X90-GB70_1 | 4 |
| 11 | 203103018 | Hex locking nut | M24X3-GB6172_2 | 2 |
| 12 | 202101021 | Cross socket cap head screw | M5X10-GB818 | 2 |
| 13 | 202109019 | Hex socket cylinder head screw | M6X12-GB70_1 | 2 |
| 14 | 202209002 | Hex socket tapping screw | M8X12-GB79 | 1 |
| 15 | 208106001 | Straight oil cup | M8YB-JB9740_1 | 4 |
| 16 | 420550010 | Adjustable head | MR35E-A09-B02 | 1 |
| 17 | 410563353 | Support holder | MS12AC-A2-B1 | 2 |

| POS. | Code | Descriptions | Specification | Qty |
|------|------------|-------------------------------------|------------------|-----|
| 18 | 614059203 | Outside support arm | MS12AC-A2-B2 | 1 |
| 19 | 614059204 | Inside support arm | MS12AC-A2-B3 | 1 |
| 20 | 420560050 | Sliding block | MS12AC-A2-B4 | 4 |
| 21 | 410562291 | Middle shaft of the support bracket | MS12AC-A2-B5 | 2 |
| 22 | 410562301 | Downside shaft of the cylinder | MS12AC-A2-B7 | 1 |
| 23 | 410562311 | Upside shaft of the cylinder | MS12AC-A2-B8 | 1 |
| 24 | 612059205B | Mechanical safety block | MS12AC-A2-B9 | 2 |
| 25 | 614059206B | Connection rod of the lock assembly | MS12AC-A2-B10 | 1 |
| 26 | 615062206 | Cylinder | YG100/117-40-280 | 1 |

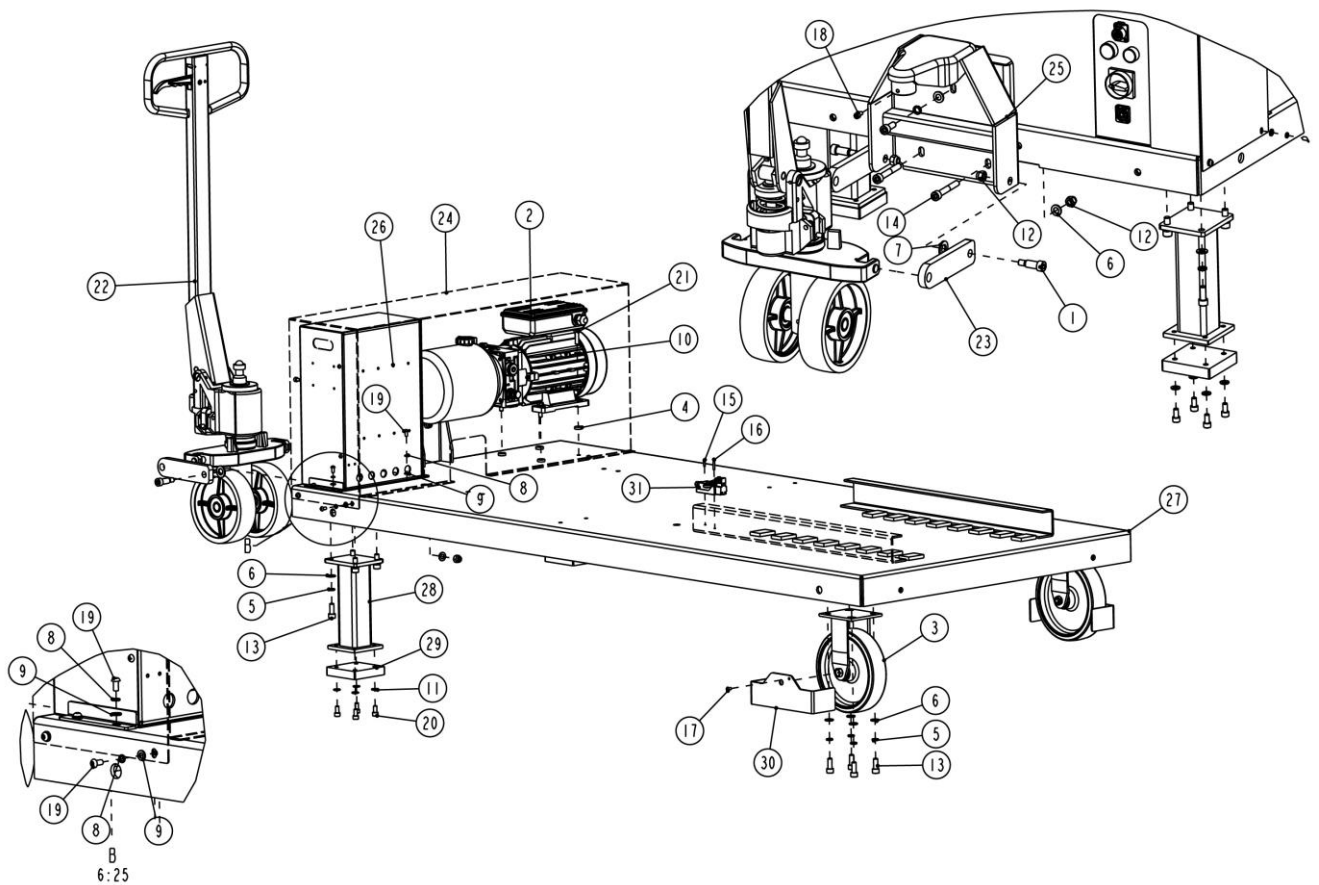

| POS. | Code | Descriptions | Specification | Qty |
|------|-----------|--------------------------------|----------------------|-----|
| 1 | 202208007 | Hex socket cylinder head screw | 13X25-GB52+D2:D2681 | 2 |
| 2 | 622034031 | Power unit | 220V-1.5KW-1PH-60HZ | 1 |
| | 622034030 | Power unit | 220V-1.5KW-1PH-50HZ | 1 |
| | 622034032 | Power unit | 110V-1.5KW-1PH-60HZ | 1 |
| | 622034044 | Power unit | 230V-1.5KW -1PH-50HZ | 1 |
| 3 | 420680063 | TPU caster | 47-08252 | 2 |
| 4 | 420040010 | Anti-shock pad | 6254E-A23 | 4 |

| POS. | Code | Descriptions | Specification | Qty |
|------|-----------|------------------------------------|---------------|-----|
| 5 | 204101006 | Flat washer | D10-GB93 | 17 |
| 6 | 204101006 | Flat washer | D10-GB95 | 19 |
| 7 | 204101008 | Flat washer | D14-GB95 | 2 |
| 8 | 204201003 | Spring washer | D6-GB93 | 10 |
| 9 | 204101004 | Flat washer | D6-GB95 | 10 |
| 10 | 204201004 | Spring washer | D8-GB93 | 4 |
| 11 | 204101005 | Flat washer | D8-GB95 | 12 |
| 12 | 203103007 | Hex locking nut | M10-GB889_1 | 5 |
| 13 | 202109042 | Hex socket cylinder head screw | M10X25-GB70_1 | 17 |
| 14 | 202109080 | Hex socket cylinder head screw | M10X70-GB70_1 | 2 |
| 15 | 202101009 | Cross socket cap head screw | M4X14-GB818 | 1 |
| 16 | 202101010 | Cross socket cap head screw | M4X25-GB818 | 1 |
| 17 | 202110001 | Hex socket button head screw | M5X8-GB70_2 | 2 |
| 18 | 202109019 | Hex socket cylinder head screw | M6X12-GB70_1 | 1 |
| 19 | 202110003 | Hex socket button head screw | M6X12-GB70_2 | 10 |
| 20 | 202109028 | Hex socket cylinder head screw | M8X16-GB70_1 | 8 |
| 21 | 201102013 | Hex socket full swivel bolt | M8X30-GB5781 | 4 |
| 22 | 615062007 | Pallet jack | MS12AC-A1-B2 | 1 |
| 23 | 410562913 | Connection rod | MS12AC-A1-B3 | 2 |
| 24 | 410901299 | Box for the control and power unit | MS12AC-A1-B4 | 1 |
| 25 | 614059217 | Cover of the Pallet jack | MS12AC-A1-B6 | 1 |
| 26 | 615068019 | Control box | MS12AC-A1-B8 | 1 |
| 27 | 614059218 | Mobile base frame | MS12M-A1-B1 | 1 |
| 28 | 614059219 | Support tube assembly | MS12M-A1-B7 | 2 |
| 29 | 420680064 | Rubber pad | MS12M-A1-B9 | 2 |
| 30 | 410901269 | Wheel deflector | MS12M-A1-B10 | 2 |
| 31 | 320301011 | Limit switch | TZ8108 | 1 |