

EZDown Instruction **EZDown Ford – ED0590**

1 THIS KIT IS ONLY TO BE FITTED ON THE RIGHT HAND SIDE OF THIS VEHICLE.

Warranty is voided if Cables are removed.

Please ensure the cables are free flowing and not over tightened and locked in position.

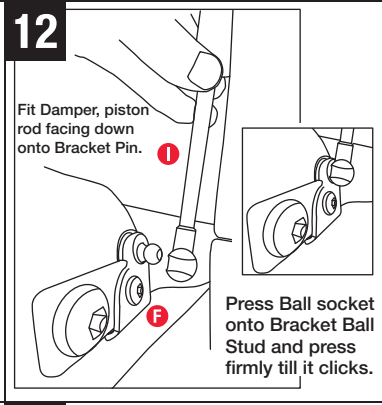
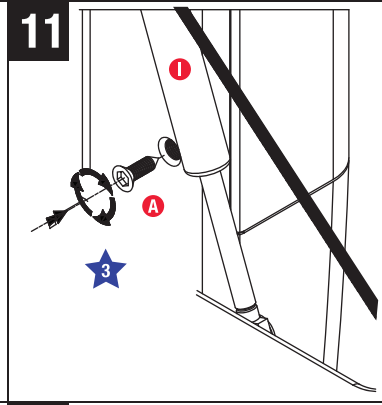
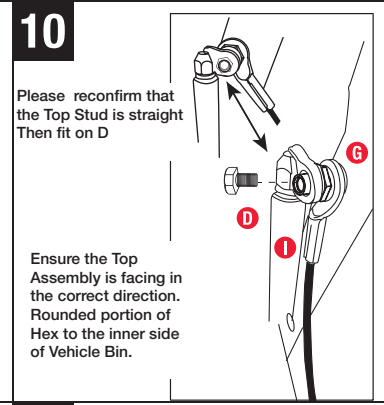
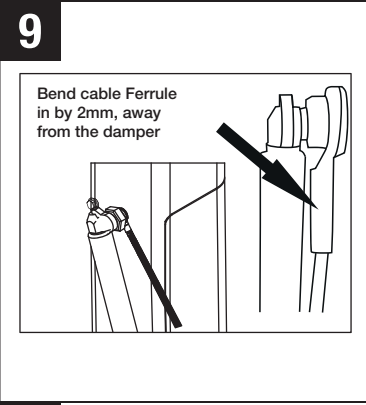
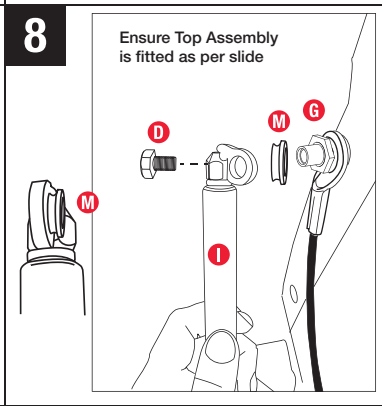
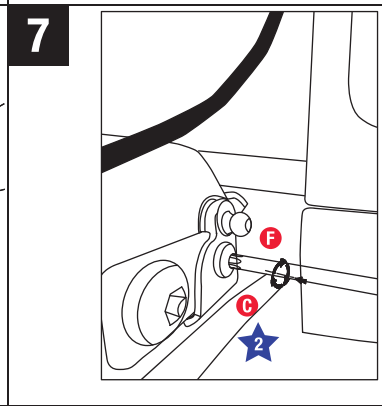
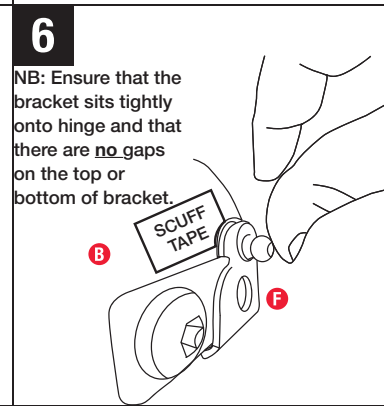
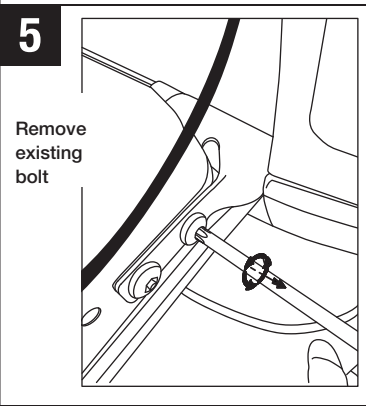
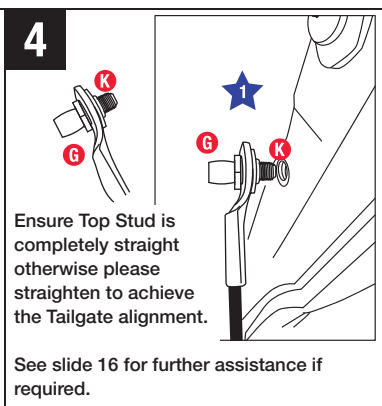
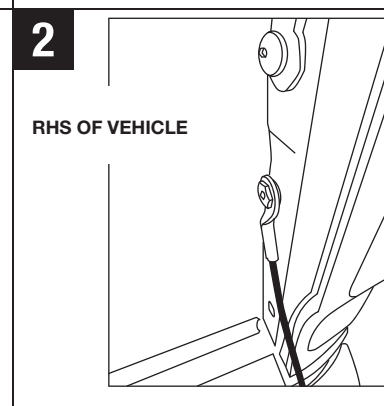

13

PLEASE ENSURE

Confirm that the Damper has some movement in the tailgate open position therefore ensuring the cables are taking the tailgate weight and not the damper.

14

Tailgate Alignment procedure:

1. Your Tailgate is misaligned when your side top of Tailgate to body is not flush.
2. If the tailgate in relation to the body is either set to far inward or outward.

15

IF THERE IS...

Place threaded bar into Top Stud Hole. Tap gently to straighten until your threaded bar is straight.

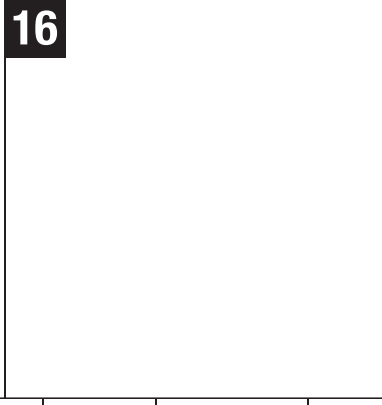

FITTING CODE	MANUFACTURER	MODEL TYPE	YEAR	STOCKIST	PRODUCT	REVISION	LABOUR	DATE	PAGE
ED0590	FORD	FORD T6	2011 onwards	GENERAL USE	EZDown	4	20min	01/07/2019	1
TORQUE – N.m	★ 25N.m ± 2N.m	★ 65N.m ± 2N.m		★ 17N.m ± 2N.m				www.ezdown.co.za	

NB: After installation please close tailgate gently to ensure that there is no interference with any hardware.

IMPORTANT:
No liability will be incurred by Industrial Specialised Applications company, for injury, death, or property damage caused by a product which has been set up, operated, and/or installed contrary to EZDown installation guide/manual, or which has been subjected to misuse, negligence, or accident, or which has been repaired or altered by anyone other than Industrial Specialised Applications, or which has been used in a manner or for a purpose for which the product was not designed.

