

Sonic

9004 Remote Mount Siren Amplifier

Installation Instructions

9004-12-GB & 9004-24-GB



Emergency Service and Utility Warning Systems

Features Overview :

- Up to 5 tones: Wail, Yelp, Hi-lo, Pulsar & Air-horn
- Tone change, start & stop from Horn press
- Run inputs
- Low volume test mode
- Day & night volume levels
- Fault indication
- Over voltage protection
- Over Current protection
- Overheating protection

- 100W / 60W Speaker Outputs
- Horn switch polarity detection
- Relay driver output for horn bypass
- Configurable operational modes
- Data output
- Reverse polarity protection
- Under voltage protection
- Speaker short circuit protection
- Low volume start mode

Approvals:

2004/104/EC as amended by (2009/16/EC)

ECE REG 10.4

10R-04 7932

NPIA specification 5 (issue 11)



As part of our policy of continuous improvement we reserve the right to change specifications without notice.

Contents:

Features overview	1
Approvals	1
Safety information	2
Electrical Information	2
Tone Information	3
Fitting Information	3
Dimensional Drawing	3
In the Box	4
Features description	5
Wiring loom Information	6
Software description for dip switch settings	6
Typical Installation diagrams	8
Description of Positive and Negative HRT detection	9
Wiring a horn bypass relay	9
Wiring day and night volume switching	10
Wire size selection matrix	10
Fault codes and Troubleshooting	11

Safety Information:

- Sirens are produced in 12 and 24 Volt versions. Ensure that you have the correct version for your installation.
- A suitable fuse and holder is provided with the siren amplifier wiring loom where bought. Otherwise the recommended fuses are: 15A fuse – 12V version and 7.5A fuse – 24V version.
- The Siren amplifier should be installed by an electrically competent person in accordance with the fitting instructions.
- Any wiring to or from the siren should be sufficient to carry the load, loads are given on page 6, there is also a wire size selection matrix on page 10 which may aid this.
- Sirens may get hot in use and they should be sited where this will not cause any hazards. Consideration should be given to allowing air flow over the amplifier.
- This equipment generates high levels of sound which may be detrimental to hearing. Care should be taken during installation and testing so as to avoid endangering yourself or others.
- Use of this equipment does not guarantee right of way over other road users and may not always be heard by them. It should be operated only by trained and competent personnel.

Electrical Information:

Operating Voltage range 12V model:	11V – 16V
Operating Voltage range 24V model:	22V – 32V
Speaker requirements:	11 Ohm impedance, 100W _{rms} loudspeaker
Standby current with power on	< 20mA
Standby current without power on	< 1mA
	(Current consumption due to feeds on the input lines, such as the horn)
Maximum operating current:	10A
Ambient operating temperature range:	- 30°C to + 60°C

Tone information

Tone:	frequency range:	cycles per minute:	Sound Pressure:
Wail	500Hz – 1800Hz	11 ¼ cpm	118dB – 121dB
Yelp	500Hz – 1800Hz	178 cpm	118dB – 121dB
Hi-lo	670Hz, 1100Hz	55 cpm	116dB – 120dB
Pulsar	500Hz – 1800Hz	650 cpm	118dB – 121dB
Air-Horn	500Hz – 1800Hz	3000 cpm	119dB – 122dB

Note: sound pressure measured from 1m, using a PA100-R loudspeaker on 100W output.

Fitting information:

Leave room for airflow around the siren (approx. 50mm).

Don't place any wiring directly on the siren casing.

The siren amplifier is not waterproof, so should be fitted in a suitable location.

Siren amplifier dimensional drawing

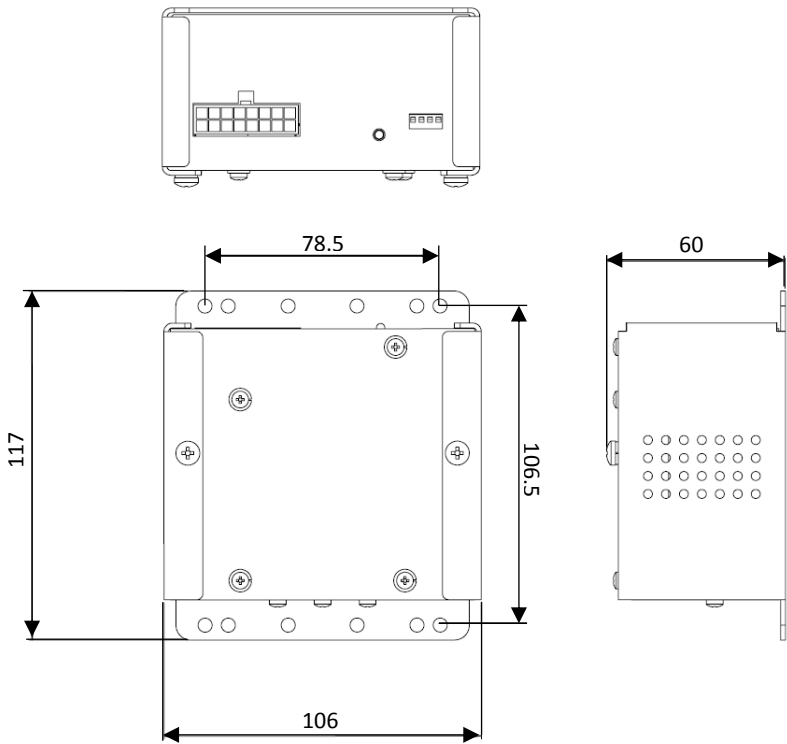

SIREN DIMENSIONS IN mm

In The Box:

9004 siren amplifier	Quantity x1	PH PN: 9004-12-GB or 9004-24-GB
Installation Instructions	Quantity x1	PH PN: D00216
Plug	Quantity x1	PH PN: 504303
Pins	Quantity x16	PH PN: 504304
Fuse (Rating dependant on voltage model)	Quantity x1	PH PN: 560400 (15A, 12V model) PH PN: 560103 (7.5A, 24V model)

Note; an 11 Ohm impedance 100W speaker is required along with the siren amplifier to produce sound. Please see page 14 for further details on Premier Hazard speakers, speaker cowls and switch accessories.



9004 SERIES
SIREN AMPLIFIER



POLY BAG
CONTAINING:
PLUG x1,
PINSx16



INSTALLATION
INSTRUCTIONS

DESPATCHED IN SUITABLE PACKAGING

Accessories:

12V change over relay SPDT	PH PN: 562601
24V change over relay SPDT	PH PN: 562602
9004-12 wiring loom kit	PH PN: ME005-000-12
9004-12 wiring loom kit	PH PN: ME005-000-24
Extra Brown / white cable for day & night volume	PH PN: 507021

Features:

Horn polarity detection – The siren amplifier detects if the horn is positive switched or negative switched on start up. The HRT wire (pin 9) should be connected to the switched side of the horn (see page 9 for full details).

Low volume start – When Low volume start is selected the siren tone sounds quietly at first then builds up from around half volume to full volume over a period of 3 seconds.

Data output – This provides a 200mA positive output feed that can be connected to a data logger, the data output is switched on when the siren is sounding and operating correctly.

Relay output – This provides a 200mA positive output feed that can be used to connect to a separate relay (available separately) so that the Horn can be bypassed when the siren is operating.

This output is active when either the tone is sounding or when the run input is selected (see page 9 for an example of the wiring).

Configurable operation modes – The operation mode and tones can be configured using the dip switches on front panel of the siren. (See pages 6 & 7 for full details) For the changes to the dip switch settings to be applied the power has to be switched off and then back on again.

Low volume test mode – The Low volume test mode is intended for use when fitting and testing the siren so that no special hearing protection is required. The Low volume mode is selected by switching dip switch 4 to the on position and deselected by switching it to the off position. For the change to the dip switch settings to be made the power has to be switched off and then back on again.

Please Note the volume can be reduced even further by running in night mode (see page 10 for wiring details)

Fault LED – The siren amplifier has a fault LED incorporated into the front panel to aid debugging and trouble shooting of any faults. The LED will flash in different patterns to identify a particular fault (see page 11 for fault codes and troubleshooting).

Circuit protection – The siren amplifier has the following protective circuitry incorporated into it to ensure that fitting errors don't cause damage to the siren or vehicle systems as well as:

- **Start delay** – the siren will not work until three seconds after power is first applied to the siren amplifier to allow voltage to stabilise after engine started, stopping damaging voltage transients effecting the speaker.
- **Reverse Polarity protection** – if the positive and ground lines have been reverse wired the siren will not function, however the siren amplifier and speaker will not be damaged by this.
- **Over temperature protection** – In the event of the siren overheating through excessive prolonged use or extreme ambient temperatures. The siren will switch off the siren output until it has cooled sufficiently to resume operation.
- **Over current protection** – if the siren amplifier circuit is drawing too much current, caused by a speaker failing or short circuit, the siren will switch off the siren output. The power to the siren amplifier will have to be reset to clear this fault.
- **Speaker short circuit protection** – if a short circuit is detected on the speaker the siren output will switch off. The power to the siren amplifier will have to be reset to clear this fault.
- **Over and under voltage protection** – if the operating voltage is out of operating parameters for the voltage version of the siren, the siren will not operate. i.e. when 12V siren fitted to 24V vehicle or if the vehicle battery is flat.

Wiring Loom information:

Pin No:	Wire Colour:	Function:	Wire rating:
1	Brown / white stripe	Speaker 100W output	10A
2	–	Speaker 60W output	10A
3	Brown	Speaker common output	10A
4	Gray	Soft start input (negative input)	1A
5	Blue	Relay output (Positive output, 200mA max)	1A
6	Not connected	No Function	–
7	Not connected	No Function	–
8	Pink	Data output (Positive output, 200mA max)	1A
9	Orange	Horn ring transfer input - HRT (pos. or neg. input)	1A
10	White	Run input (Positive input)	1A
11	Violet	Air-Horn input (Negative input)	1A
12	Green	Input 3 (Negative input)	1A
13	Yellow	Input 2 (Negative input)	1A
14	Yellow / black stripe	Input 1 (Negative input)	1A
15	Black	Battery ground return	10A
16	Red	Battery power input	10A

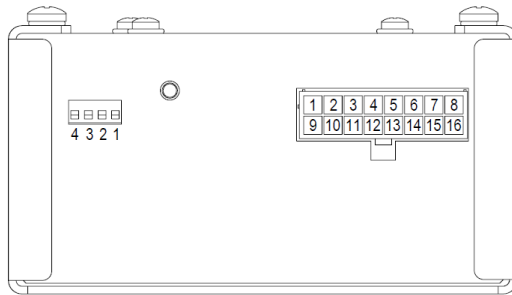

CONNECTOR PIN OUTS & DIP SWITCH TOGGLES IDENTIFICATION

Software description / operating modes:

The operations mode is controlled by the DIP switch settings which are read when the siren is first powered up. If a change to the dip switch setting's is made it will not be implemented until the power to the siren amplifier has been reset.



Low volume test mode off

This switches the tone generation to normal operating mode, full volume.



Low volume test mode on

This switches the tone generation to low volume mode, so that the siren system can be tested in a workshop or garage without the need for special hearing protection.



Mode 0 - Wail, Yelp, Hilo, Pulsar, using negative inputs and HRT to toggle tone

- Grounding input 1 will play the wail tone, pressing HRT will switch the tone to yelp, further presses of HRT toggle between Wail and Yelp. Releasing input 1 will stop the tone from sounding.

- Grounding input 2 will play the Yelp tone, pressing HRT will switch the tone to HILO tone, further presses of HRT toggle between YELP and HILO. Releasing input 2 will stop the tone from sounding.
- Grounding input 3 will play the HILO tone, pressing HRT will switch the tone to PULSAR, further presses of HRT toggle between HILO and PULSAR. Releasing input 3 will stop the tone from sounding.



Mode 1 - Wail, Yelp, Hilo, Pulsar, using negative inputs and HRT to toggle tone, run to enable

- Putting a positive feed on the run input will enable the following tones to work, removing this feed will stop the tones working.
- Grounding input 1 will play the wail tone, pressing HRT will switch the tone to yelp, further presses of HRT toggle between Wail and Yelp. Releasing input 1 will stop the tone from sounding.
- Grounding input 2 will play the Yelp tone, pressing HRT will switch the tone to HILO tone, further presses of HRT toggle between YELP and HILO. Releasing input 2 will stop the tone from sounding.
- Grounding input 3 will play the HILO tone, pressing HRT will switch the tone to PULSAR, further presses of HRT toggle between HILO and PULSAR. Releasing input 3 will stop the tone from sounding.



Mode 2 - Wail, Yelp, start from HRT, double press to stop, run to enable

- Putting a positive feed on the run input will enable the following tones to work, removing this feed will stop the tones working.
- The first press of the HRT will start the siren sounding in Wail tone, pressing the HRT switches the tone to Yelp, successive presses of HRT toggle though the wail and yelp tones.
- A double press of the HRT stops the tone from sounding, placing the siren into standby.



Mode 3 - Wail, Yelp, Hilo, start from HRT, double press to stop, run to enable

- Putting a positive feed on the run input will enable the following tones to work, removing this feed will stop the tones working.
- The first press of the HRT will start the siren sounding in Wail tone, pressing the HRT switches the tone to Yelp, successive presses of HRT toggle though the wail, yelp, Hilo tones.
- A double press of the HRT stops the tone from sounding, placing the siren into standby.



Mode 4 - Wail, Yelp, Pulsar, start from HRT, double press to stop, run to enable

- Putting a positive feed on the run input will enable the following tones to work, removing this feed will stop the tones working.
- The first press of the HRT will start the siren sounding in Wail tone, pressing the HRT switches the tone to Yelp, successive presses of HRT toggle though the wail, yelp, pulsar tones.
- A double press of the HRT stops the tone from sounding, placing the siren into standby.



Mode 5 - Wail, Yelp, Hilo, Pulsar, start from HRT, double press to stop, run to enable

- Putting a positive feed on the run input will enable the following tones to work, removing this feed will stop the tones working.
- The first press of the HRT will start the siren sounding in Wail tone, pressing the HRT switches the tone to Yelp, successive presses of HRT toggle though the wail, yelp, Hilo, pulsar tones.
- A double press of the HRT stops the tone from sounding, placing the siren into standby.



Mode 6 - Not used, if it is selected it will default to setting mode 1



Mode 7 - Test mode for Premier Hazard use only.

Typical installation diagram – operation modes 0, 1 & 6

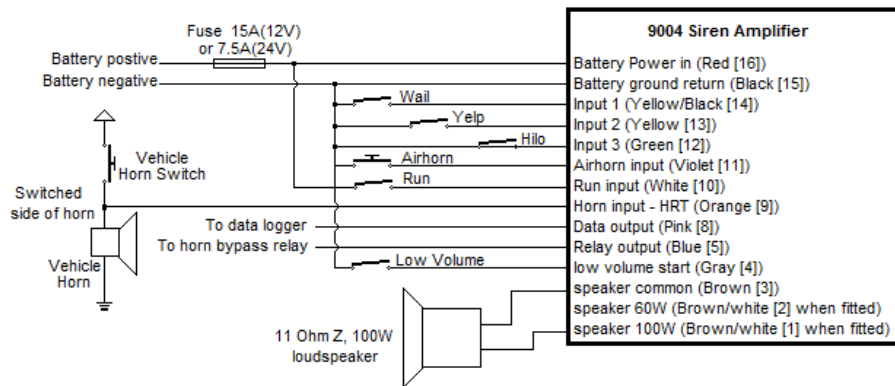

Typical installation diagram – operation modes 2– 5

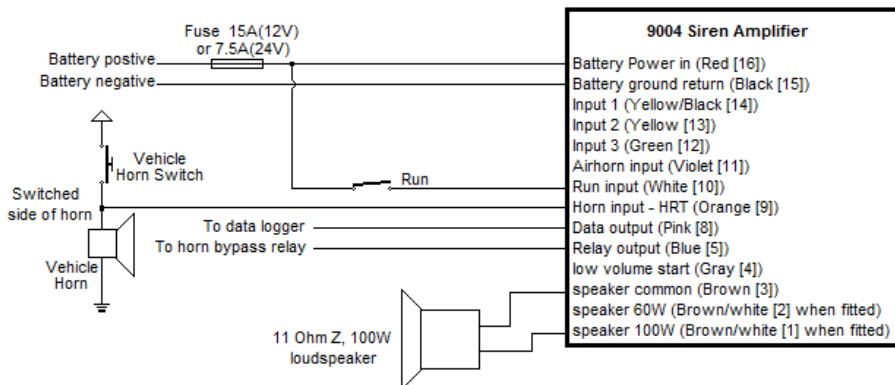

Positive & Negative HRT detection:

The Siren amplifier detects if the horn ring transfer is positive or negative switched at start up. If the HRT input senses a positive feed it must be a negative switched horn, if it doesn't sense a positive feed it must be a positive switched horn. The HRT input just needs to be connected to the switched side of the vehicle horn for the detection to work.

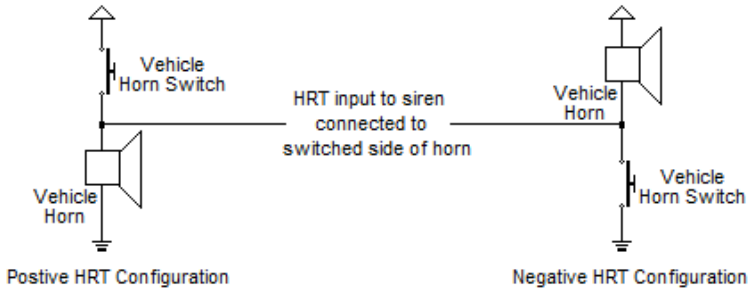

Occasionally there can be a problem when fitting over the top of an old system where a positive to negative HRT change over relay has been fitted. As the siren amplifier is looking for a positive feed when the horn is not pressed and no feed when the horn is pressed. Either connecting the positive horn feed directly to the HRT input or wiring the relay as shown below should resolve this issue.

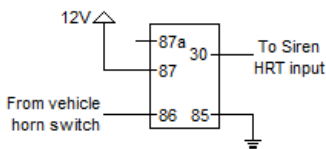

Key:	
30	Common contact
87	Normally open contact
87a	Normally closed contact
86	Coil positive input
85	Coil ground return

Wiring a horn bypass relay:

The diagram below shows how to connect the HRT input and relay output of the siren amplifier to additional components to act as horn by pass for either a positive or negative switched horn.

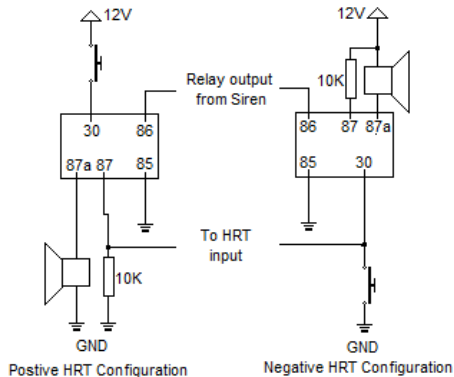

Recommended resistor value: 10K, 0.25W, radial.

Day & Night Volume Switching

Below are two different wiring possibilities for wiring a switch to control the siren output for day and night volume levels.

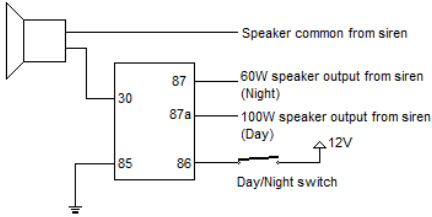

Day and night switching using relay

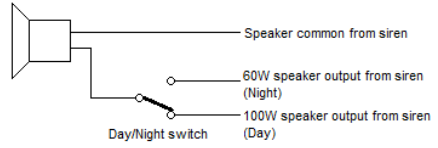

Day and night switching using SPDT Switch

SPDT switch PH PN: 502

Note: SPDT switch can be used for both operations, when using SPDT switch it must be rated correctly for the current passing through it (6A).

Wire size selection matrix:

Wire CSA		Maximum permissible current over distance					
mm ²	AWG	5A	10A	15A	20A	25A	30A
0.34	22	1.8m	0.9m	X	X	X	X
0.5	20	2.9m	1.5m	0.9m	X	X	X
0.75	18	4.5m	2.2m	1.5m	1.2m	0.9m	X
1.5	16	7.5m	3.5m	2.4m	1.8m	1.5m	1.2m
2.5	14	12m	6m	4m	2.8m	2.5m	2m
4	12	20m	9.5m	6m	4.7m	3.8m	3.2m
6	10	30m	15m	10m	7.5m	6m	5m
10	8	48m	24m	16m	11.8m	9.4m	8m
16	6	75m	37m	25m	18.8m	15m	12.6m
25	4	120m	60m	40m	30m	24m	20m

Notes:

Wire Crimping

It is the purchaser’s responsibility to use a compatible crimping tool when fitting wire crimps (PH part No. 504304, manufactured by T.E. Connectivity, Man part No. 794956 – 1), to ensure correct quality of crimp connections.

Fault Codes:

When the siren amplifier detects a problem with its operation it flashes the fault LED on the front of the unit, fault patterns below. The fault light should be treated as a warning of improper operation and possible causes should be investigated. The trouble shooting table below may assist with this, note this is not intended to be an exhaustive list and is a guide only all work should be carried out by an electrically competent person.

Flash Pattern	Detected Fault
Steady on	Short circuit on speaker detected
Steady flashing (on, off)	Over heated
Two flashes with a pause	Under voltage
Three Flashers with a pause	Over voltage
Four flashes with a pause	Over current, or short circuit

Troubleshooting:

Problem	Possible solutions
No siren tone output	Check power to siren Check if fuse blown Check speaker connected Check run input connected (if required)
Fuse blown	Check cabling for shorts Particularly wires passing through panels Replace fuse
Fuse Keeps blowing when starting a tone	Check speaker cables for shorts Check speaker resistance (should be $4.4R \pm 1R$) Try running without speaker connected (tone should be audible at siren, without blowing fuse)
Overheated fault indicated	Wait for siren to cool and operation should resume. Check that siren has sufficient air gap to allow for air flow. Ensure that siren is fitted away from other equipment that may get hot.
Under Voltage fault indicated	Check battery voltage (may be below 11V) Check correct voltage version of siren is fitted Check cabling is rated correctly (if under rated may have a voltage drop down line) Check ground return to battery (ground could be unstable)
Over Voltage fault indicated	Check correct voltage version of siren is fitted Check battery voltage (may be over charged) Check alternator is attached to battery correctly
Over Current fault indicated	Check speaker resistance (should be $4.4R \pm 1R$) Check speaker cable for shorts Check alternator connected to battery Check power to siren (could be unstable, due to alternator problem, grounding, cabling or another device fitted to vehicle)

9004 SIREN AMPLIFIER ACCESSORIES



502



504



509

SWITCH PANELS



509A



SPEAKER
PA100-R



SPEAKER & FLUTE
PA100-A



R – SPEAKER COWL



S – SPEAKER COWL



C – SPEAKER COWL



L – SPEAKER COWL



M – SPEAKER COWL



SONIC WIRING HARNESS
ME05 SERIES

IMAGES NOT
TO SCALE