



USERS MANUAL

M-SQ20 / 25

- 1500 RPM -

Marine diesel generating set 230/400V / 50Hz

Digital Diesel Control



Art.nr. . 40200441

WHISPER POWER BV
Kelvinlaan 82
9207 JB Drachten
Netherlands
Tel.: +31-512-571550
Fax.: +31-512-571599
www.whisperpower.eu

V1. November 2010

CONTENTS:

1	INTRODUCTION.....	4
1.1	General	4
1.2	Service and maintenance	4
1.3	Guarantee	4
1.4	Liability	5
1.5	Identification	5
1.5.1	General.....	5
1.5.2	Identification plate	5
2	INFORMATION.....	7
2.1	Safety	7
2.1.1	General.....	7
2.1.2	Electrical safety	7
2.1.3	Earth insulation failures	7
2.1.4	Installation	7
2.1.5	Operation.....	8
2.1.6	Fire and explosion	8
2.1.7	Chemicals.....	8
2.2	Transport, lifting and storage.....	9
2.3	The M-SQ20 / 25.....	9
2.3.1	Features	9
2.3.2	Remote control	9
2.3.3	Documentation	9
2.3.4	Accessories included in the standard delivery.....	9
2.4	Components	10
2.4.1	Main components	10
2.4.2	Generator control panel.....	12
2.4.3	Remote control panel	12
2.5	Technical Information	12
2.5.1	AC alternator	12
2.5.2	Engine	13
2.5.3	Digital Diesel Control system.....	13
2.5.4	Battery charger	13
2.5.5	Alarms and shut down	13
2.5.6	Monitoring.....	13
2.5.7	Control.....	14
2.5.8	Remote control	14
2.5.9	Hour counter.....	14
2.5.10	Load indicator	14
2.5.11	Fuel specification.....	14
2.5.12	Oil information	14
2.5.13	Cooling liquid.....	14
2.5.14	Technical data	15
2.5.15	Electrical diagram control wiring M-SQ20 / 25.....	16
2.5.16	Terminal modes 115V 400C 50Hz.....	17
2.5.17	Generator Diagram 3 phase with AVR 230V – 400V 50Hz with AVR.....	18
2.5.18	AC Wiring Diagram single phase with AVR 230V Hz (Double Delta)	19

3	OPERATION	20
3.1	General	20
3.2	Operating Instructions	20
3.2.1	Summarised operating instructions (daily use)	20
3.2.2	Extended operating instructions	20
4	MAINTENANCE	23
4.1	Alternator	23
4.2	Engine	23
4.2.1	Preliminary instructions	23
4.2.2	Bleeding fuel lines	23
4.2.3	Valve clearance	23
4.2.4	Replacing fuel filter	23
4.2.5	Replacing oil filter	24
4.2.6	Tensioning V-belt	24
4.3	Regular maintenance	25
4.3.1	Maintenance schedule	26
4.3.2	Taking out of service	26
5	TROUBLE SHOOTING	27
5.1	Alternator/ electrical faults	27
5.1.1	General	27
5.1.2	Trouble shooting table	27
5.2	Engine faults	28
5.2.1	General	28
5.2.2	Trouble shooting table	29
5.2.3	Warnings	32
5.2.4	Service address	32
5.3	Special procedures alternator	32
5.3.1	Automatic Voltage Regulator (AVR)	32
5.3.2	Residual voltage check / excitation procedure (flashing)	33
5.3.3	Testing rotary rectifier diodes	33
5.3.4	Winding resistant values	33
5.3.5	Meggering	34
5.4	Special procedures engine	34
5.4.1	Setting the RPM	34
5.4.2	Adjusting valve clearance and retightening the cylinder head bolts.	35
5.4.3	Measuring exhaust backpressure	35
5.4.4	Disassembling instructions	36
6	SPARE PARTS	38
	MAINTENANCE LOG	41

1 INTRODUCTION

1.1 General

This manual applies to the WhisperPower M-SQ20 / 25 generating set controlled by Digital Diesel Control first launched in September 2005. For other models see other manuals available on our website: www.whisperpower.eu.

The M-SQ20 / 25 Marine Diesel Generating set is manufactured and marketed by WhisperPower.

It is important to read this manual before installing and operating the generating set. Both safety and durability rely very much on the correct identification, installation and a good understanding of ratings, features, design, maintenance and operation procedures.

The information, specifications, illustrations and statements contained within this publication are given with our best intentions and are believed to be correct at the time of going to press.

Our policy is one of continued development and we reserve the right to amend any technical information without prior notice.

Whilst every effort is made to ensure the accuracy of the particulars contained within this publication neither the manufacturer, distributor, or dealer in any circumstances shall be held liable for any inaccuracy or the consequences thereof.



WARNING

A warning symbol draws attention to special warnings, instructions or procedures which, if not strictly observed, may result in damage or destruction of equipment, severe personal injury or loss of life.



DANGER

This danger symbol refers to electric danger and draws attention to special warnings, instructions or procedures which, if not strictly observed, may result in electrical shock which will result in severe personal injury or loss of life.

1.2 Service and maintenance

Regular service and maintenance should be carried out according to the directions in this manual. For service and maintenance one can appeal to the manufacturer or the dealers.

1.3 Guarantee

WhisperPower guarantees that this generating set has been built according to good workmanship, according to the specifications in this manual and according to European Community safety regulations.

During production and prior to delivery, all of our generating sets are tested and inspected.

The well functioning of this generating set is subject to guarantee. The period and conditions of this guarantee are laid down in the general conditions of delivery as registered with the Chamber of Commerce and Industries for the North of the Netherlands number 01120025. The guarantee period is two years, limited to 1000 running hours. Some aspects of our guarantee scheme are given here in more detail:

Guarantee does not cover failures that are caused by misuse, neglect or a faulty installation.

Example 1. Faulty installation:

Seawater entering the engine is the most common cause of damage to combustion engines in boats. (Both to propulsion and generator engines.) The entry of water must be avoided under all conditions. Be aware that the conditions in blue water sailing can be extreme. See the installation manual for instructions but remember these are for guidance only as many factors influence the installation of a generator. The ultimate responsibility will always be with the owner to ensure a safe and compliant installation.



WARNING

Damage caused by the ingress of water is never covered by guarantee.

Example 2: Misuse:

Long term running with no load or too little load can cause the exhaust to get choked with soot or carbon. Cleaning the exhaust is not covered by guarantee.

Example 3: Neglect

Sometimes the seal of the raw water pump starts leaking. Mostly this begins with a little drip and slowly gets worse. Regular visual inspection of the generator is necessary to prevent damage to occur from a leaking water pump. When one find serious damage after weeks of neglect guarantee claims will not be honoured.

Example 4: Neglect

Whisper generators have an option for an auto start/stop mode or interval mode.

WhisperPower cannot be held responsible for damage caused by the unattended running generator.

Guarantee means that faulty parts are repaired or replaced free of charge. If necessary the whole generator unit will be exchanged. Labour necessary to complete repairs on board a vessel executed by an authorized service engineer is covered, but is limited to a reasonable number of hours and reasonable rates in relation to the actual repair work that has to be done.

Travel expenses and travel hours are not covered. Also not covered is the labour required to take a generator out of a boat or for reinstallation. There is no cover for labour needed to get access to the generator, for example to remove equipment or bulkheads etc.

Goods to be delivered under guarantee will be invoiced. Only after the faulty goods are returned will the invoice be credited. Payment in advance may be required or guaranteed by credit card. If after the faulty goods are returned, it is indicated that the failure was not covered by guarantee a credit will not be issued. For example if a Printed Circuit Board is returned with clear damage caused by seawater, guarantee will be refused.

Freight costs to deliver spares by normal mail or carriers is covered under guarantee. Special services like express mail, overnight delivery etc. are not covered. Taxes and duties are not covered. For shipments to remote off shore areas any additional costs incurred over normal carriage will be invoiced to the customer.

The cost for returning faulty goods is not covered under guarantee.

1.4 Liability

WhisperPower does not accept responsibility for damage, injuries or casualties which are the result of operation of the generating set in specific conditions which brings dangers which could not be foreseen, or could be avoided by additional measures. WhisperPower does not accept liability for damage due to use of the generator, possible errors in the manuals and the results thereof.

Automatic start/stop

WhisperPower cannot be held responsible for damage caused by the unattended running generator using the auto-start/stop mode or interval mode.

1.5 Identification

1.5.1 General

Before using this generating set it is very important to identify the set correctly. To communicate for service or ordering parts it is also essential to correctly identify the generating set. Also for the daily operation of the generating set it is necessary that the operator knows the correct specifications.

1.5.2 Identification plate

All required identification data are on the identification plate.

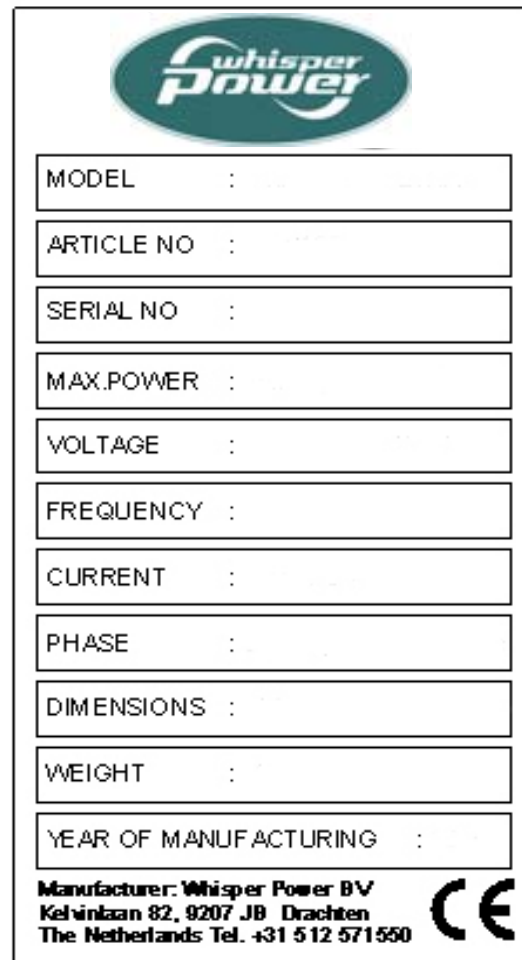



	
MODEL	:
ARTICLE NO	:
SERIAL NO	:
MAX.POWER	:
VOLTAGE	:
FREQUENCY	:
CURRENT	:
PHASE	:
DIMENSIONS	:
WEIGHT	:
YEAR OF MANUFACTURING	:
Manufacturer: Whisper Power BV Kelvinlaan 82, 9207 JB Drachten The Netherlands Tel. +31 512 571550	
	

Fig. 1: Identification plate.

- 1 The identity of the generating set is given by the SERIAL NUMBER.

When this number is available the manufacturer can trace the specifications of the generating set. On the nameplate are also some basic features of the set:

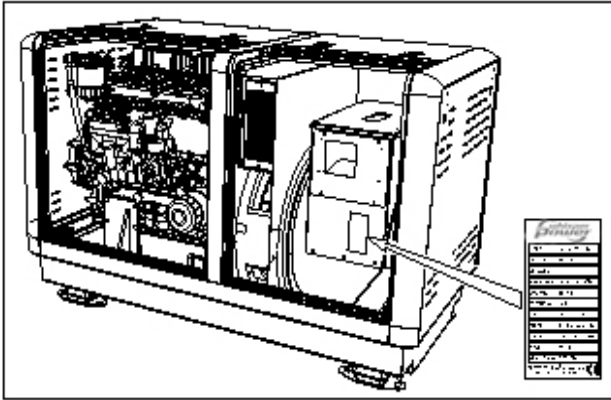

Fig. 2: Location identification plate.

2 POWER

The nameplate gives the nominal maximum continuous load in kVA = kW calculated with power factor one. When calculating a load one should always take into account the power factor or cos phi of this load. The power should never exceed the nominal power as shown on the nameplate. Power is rated at an ambient temperature of 40°C and a seawater temperature of 25°C. For higher temperatures the generating set has to be de-rated.

3 VOLTAGE. This shows the nominal voltage.

This voltage should be within the specified tolerance at the nominal frequency. The M-SQ20 / 25 can be connected for different voltages in single phase or tri phase. The nameplate indicates the connection as made in the factory; **BE AWARE THAT THE CONNECTIONS COULD BE RECONNECTED BY FORMER USERS**

- 4 **FREQUENCY.** This is shown in Hz and is determined by the speed of the engine (RPM). 50 Hz correlates with 1500 rpm.
- 5 **CURRENT.** This shows the maximum current that is acceptable at the specified frequency, voltage and power factor. When connected in tri phase the indicated current is the current between two phases that can be taken off three times.
- 6 **WEIGHT** shows the net dry weight (approximately) in kg. This is without fuel, oil, packing and external installation equipment
- 7 **CE MARKING.** The CE symbol shows that the generating set is build according to European Community safety regulations. This includes the regulations regarding the safety of pleasure craft, safety of machinery, regarding electric safety and electric magnetic compatibility (EMC).

Safety also relies on the installation, application and circumstances. See also the remarks in this manual under **SAFETY**.

Before changing a factory setting you are advised to consult the manufacturer. When the generating set you have to identify is not new you have to take into account the possibility that former users did change the settings. Check the settings (voltage, frequency, rpm) when there is any doubt.

2 INFORMATION

2.1 Safety

2.1.1 General

When correctly installed and used in normal circumstances this generating set fulfils EC safety regulations. This generating set could be part of an installation or could be used in a way that additional regulations of the EC or other authorities have to be taken into account.



DANGER

Warning signs draw attention to special warnings, instructions or procedures which, if not strictly observed, may result in electrical shock which will result in severe personal injury or loss of life.

Circumstances could make it also necessary to take additional measures. Be aware of wet conditions and hazardous environments caused by explosive gases etc

2.1.2 Electrical safety



This warning sign indicates parts which could be live. The voltage of 230V or 230V/400V generated by this generating set is dangerous and if instructions and procedures are not strictly observed may result in electrical shock which will result in severe personal injury or loss of life.

- Check all wiring at least once a year. Defects, such as loose connections, burned cables etc. must be repaired immediately.
- Do not work on the electrical system if it is still connected to a current source. Only allow changes in your electrical system to be carried out by qualified electricians.
- Using the auto-start/stop (interval) mode the generator can start unexpectedly. When working on the electrical system, the 3 Amp fuse must be removed from the control panel and the battery plus cable must be removed from the battery.
- Connection and protection must be done in accordance with local standards.

2.1.3 Earth insulation failures

According to local regulations and depending on the application it could be necessary to take measures for protection against earth insulation failures.

In the standard delivery “neutral” and “ground” are not connected. To make a connection between “neutral” and “ground” could be necessary as part of a specific insulation failure protection system.

Small pleasure craft in Europe is submitted to The Recreational Craft Directive 94/25/EC. The guidelines of this directive refer to (ISO 13297).

When the installation complies with this standard the “neutral” and “ground” should be connected on the generating set.

Be aware that insulation protection systems can be different for different applications and even within the ship there could be different standards for different spaces. We did refer to the Recreational Craft Directive that applies to pleasure craft up to 24 m of length. Sometimes one has to comply with other standards such as the rules of certification societies like Lloyds Register of Shipping or Veritas, regulations for the protection of personal, building legislation, etc. It is of the greatest importance to have expert advice on this issue.



In all situations the transfer switches between shore, inverter and generator should switch both neutral (N) and all phase lines (L1, L2 and L3).

2.1.4 Installation

Whisper generating sets are not self contained and have to be properly installed in enclosed areas such as a machine room.



Installation includes measures to be taken to outlet exhaust fumes which contain carbon monoxide and are extremely dangerous. Carbon monoxide (CO) is an invisible odourless gas. Inhalation produces headache, nausea or death. Installation includes measures for proper ventilation, safe electric connections, safe installation of the starting battery, proper fitting of the cooling system and fuel pipes etc. See the installation manual.

2.1.5 Operation

External moving parts like fans and V-belts are covered by the canopy and therefore the M-SQ20 / 25 is very safe when the canopy is closed.



Nevertheless take note of the signs on the generating set which show symbols in a triangle indicating danger.



When service has to be carried out while the engine is running, be aware of moving parts like V-belts.

- The generating set should be operated by authorised personnel only.
- Be aware of hot parts and especially parts of the exhaust system and cooling system.
- If the generating set is unsafe, fit danger notices and disconnect the battery positive (+) lead so that it cannot be started until the condition is corrected.
- Do not attempt to operate the generating set with a known unsafe condition. Disconnect the battery positive (+) lead prior to attempting any repairs or cleaning inside the enclosure.
- Always consult the manual before carrying out maintenance.
- Do not change the settings without consulting the manufacturer. Keep a record of setting changes in this manual.

2.1.6 Fire and explosion



Fuels can be flammable. Proper handling limits the risk of fire and explosion.

- Avoid refilling the fuel tank while the engine is running. When oil or fuel is leaking do not use the generating set.
- Do not run the engine close to explosives or gasses.
- Hydrogen gas generated by charging batteries is explosive. Take measures for proper ventilation. Do not smoke or allow sparks, flames, or other sources of ignition around batteries.
- Keep a fire extinguisher on hand.



Fig. 3 Fire extinguisher port.

- In case of fire do not open the soundshield. To avoid serious injury or death from fire, shut down engines, generator sets and blowers. Break through the label which is indicated by BREAK THROUGH HERE and then immediately discharge entire contents of gaseous portable fire extinguisher through the fire extinguisher port. On the generating set this fire extinguisher port is indicated by the label as shown in figure 3.
- Poor electrical connections or using wiring which is not suited for the rated currents can cause overheating and possibly fire.

2.1.7 Chemicals

- Fuels, oils, coolants, and battery electrolyte can be hazardous to personnel if not treated properly. Do not swallow or have skin contact with these liquids. Do not wear clothing that has been contaminated by fuel or lubricating oil.
- Gaskets may be manufactured from asbestos. Particles of this material should not be inhaled as this may result in fatal diseases.
- On no account allow any unprotected skin to come into contact with the injector spray as the fuel may enter the blood stream with fatal results.
- Engines may be fitted with seals or O-rings manufactured from "viton" or similar material. When exposed to abnormal high temperatures in excess of 400°C an extremely corrosive acid is

produced which cannot be removed from the skin. If signs of decomposition are evident, or if in doubt, always wear disposable heavy duty gloves.

2.2 Transport, lifting and storage



When lifting the generating set avoid any risk of personal injuries, do not stand under the generating set.

- Use soft slings to avoid damage
- On the engine are lifting eyes, which can be used to take the generator out of the capsule. The lifting eyes can also be used to lift the entire generator set, including the capsule
- After transporting the generating set check for damage before installation.
- Long term storage can have detrimental effects on engine and alternator. The engine should be put through an engine preservation procedure. (See the maintenance chapter)
- The alternator windings tend to condense. To minimise condensation, store the generating set in a dry and warm storage area.
- After removing the generating set from long term storage perform an insulation check. (See the alternator maintenance paragraph for procedures)
- While the battery is stored it should be recharged every 12 weeks.

2.3 The M-SQ20 / 25

2.3.1 Features

This generating set includes a 4 cylinder diesel engine which is connected by close coupling to a tri phase synchronous alternator in a sound attenuated capsule. The set is mounted on a steel base frame and mounted securely on anti vibration mounting pads to the capsule base. The complete set is again on rubber mountings. All cables and hoses are guided through the capsule's sides. The set is not self contained and is only operable after proper installation using additional accessories and installation materials.

Installation accessories are listed in the installation manual and are available through the supplier of the generating set. The full automatic Digital Control is based on microprocessor technology. Several automatic start/stop functions can be programmed and monitored (see Digital Diesel Control user manual).

2.3.2 Remote control

The full automatic remote control panel including 15 mtr cable comes as standard with the M-SQ20 / 25.

2.3.3 Documentation

Included in the delivery is this user manual (number: 40200441), an installation manual (number: 40200451), a user manual for DCC (number: 40200461) and a quick reference guide for the DDC (40200275).

Not included in the standard delivery but available as options are:

- Parts manual; number: 40200187
- Workshop manual; number: 40200174

However in this manual there is a list of important parts for maintenance and spare parts as well as a chapter on maintenance and problem solving.

All manuals are available on our web site www.whisperpower.eu.

2.3.4 Accessories included in the standard delivery

- Expansion tank, hose and fittings
- Template to mount the generator

2.4 Components

2.4.1 Main components

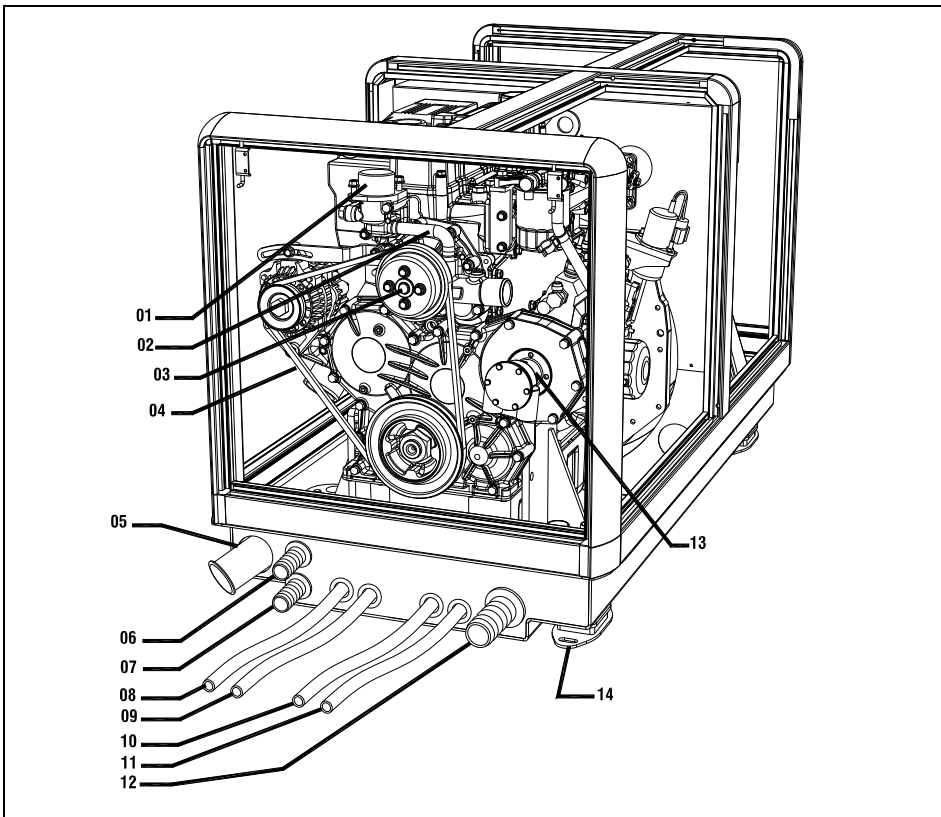

- 01 Thermostat housing
- 02 Boiler connection
- 03 Engine coolant pump
- 04 V-belt
- 05 Exhaust connection
- 06 Bypass cooling water out
- 07 Bypass cooling water in
- 08 Battery +
- 09 Battery -
- 10 Fuel out
- 11 Fuel in
- 12 Raw water inlet
- 13 Raw water pump
- 14 Rubber engine mounting

Fig. 4: Left View main components M-SQ20 / 25

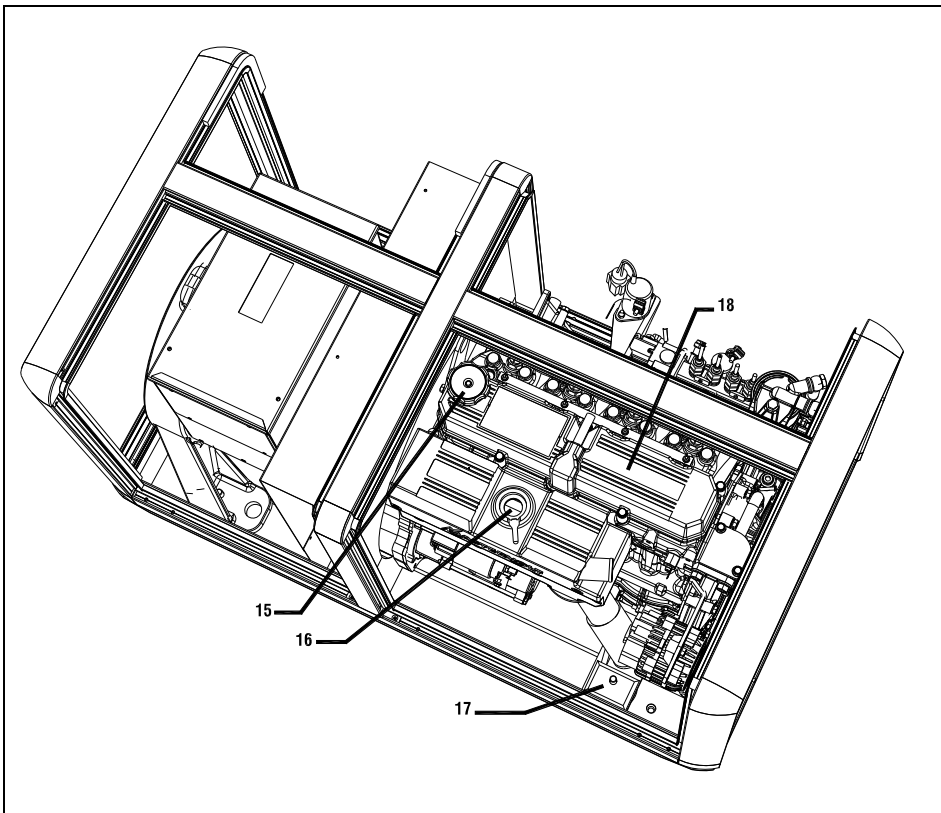

- 15 Filler cap engine oil
- 16 Filler cap engine coolant
- 17 Rubber engine mounting
- 18 Rocker cover

Fig. 5 Top View main components M-SQ20 / 25

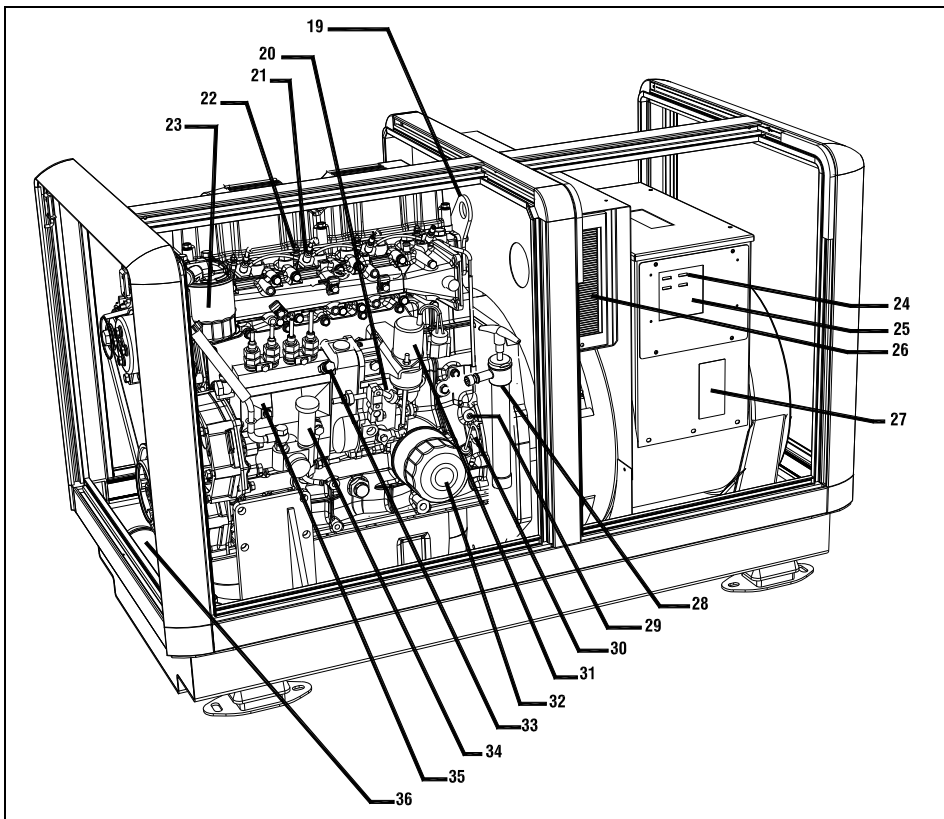

Fig. 6 Front View main components M-SQ20 / 25.

- 19 Hoist eye rear
- 20 Engine speed adjusting screw
- 21 Fuel injector
- 22 Glowplug (4x)
- 23 Fuel filter
- 24 Fuses
- 25 Control panel
- 26 Air cleaner element
- 27 Identification plate
- 28 Oil swump handpump
- 29 Coolant drain plug
- 30 Engine oil dipstick
- 31 Fuel solenoid
- 32 Oil filter
- 33 Injection pump air bleeding screw
- 34 Fuel lift pump for manual priming
- 35 Fuel injection pump
- 36 Heat exchanger

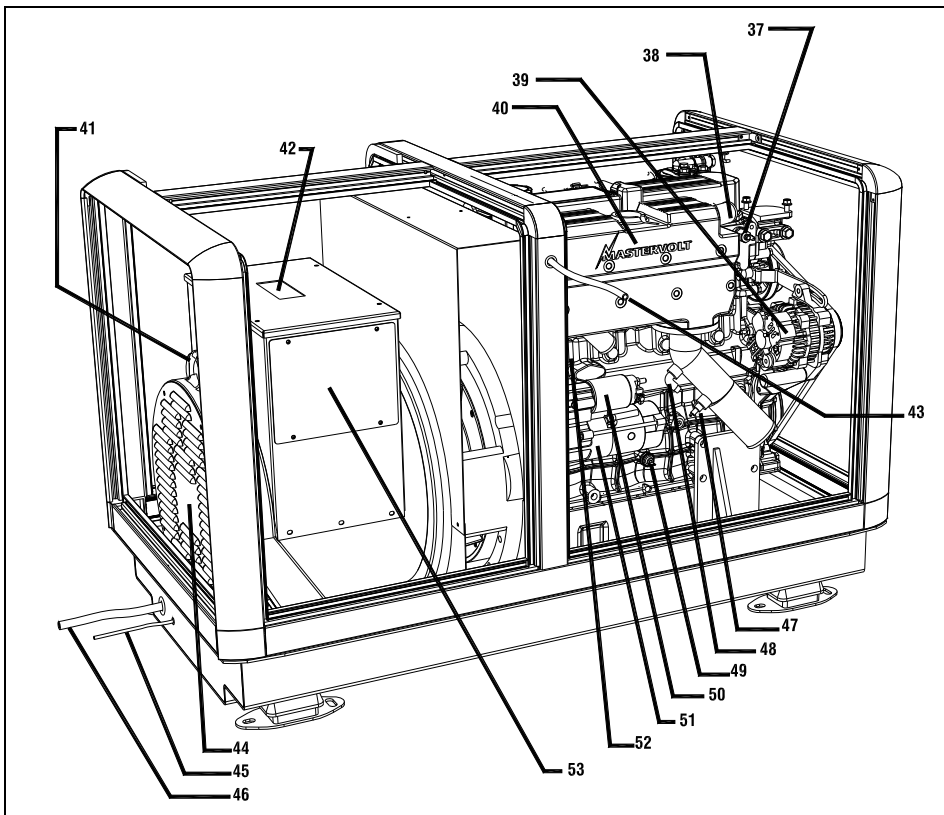

Fig. 7: Rear View main components M-SQ20 / 25.

- 37 Temperature switch
- 38 Hoist eye front
- 39 Alternator
- 40 Exhaust manifold (watercooled)
- 41 Hoist eye alternator
- 42 Digital Diesel Control (DDC)
- 43 Expansion tank
- 44 Power take off hydro pump
- 45 Remote control
- 46 AC power output
- 47 Temperature switch exhaust
- 48 Cooling water injection bend
- 49 Engine oil pressure switch
- 50 Starter motor solenoid
- 51 Starter motor
- 52 Engine serial number (above starter motor solenoid)
- 53 Automatic voltage regulator (AVR)

2.4.2 Generator control panel

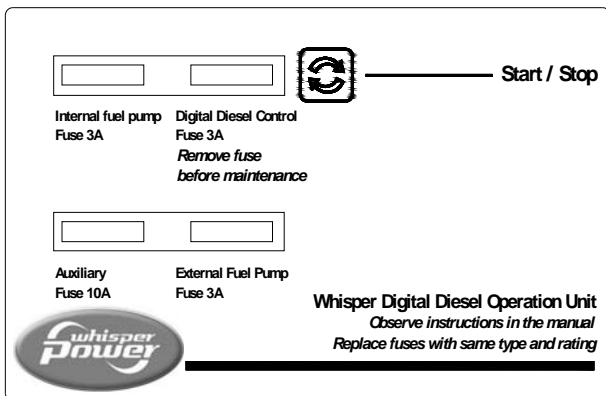

Fig. 8 Control panel.

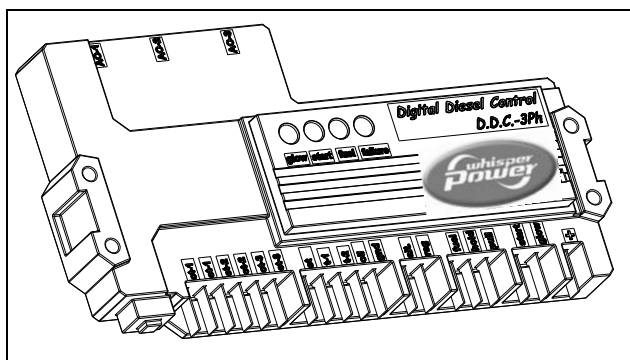
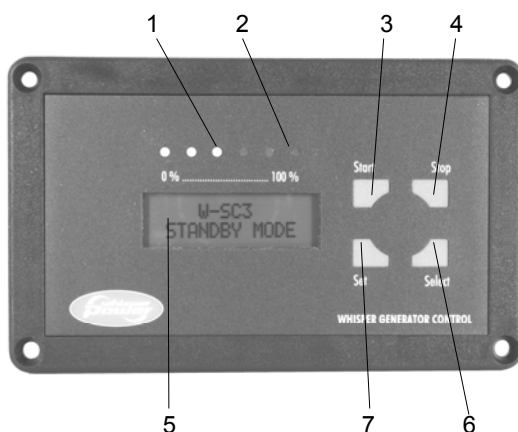

Fig. 9 Digital Diesel Control unit

2.4.3 Remote control panel



- 01 Generator load indicator
- 02 Failure LED
- 03 Start button
- 04 Stop button
- 05 Display
- 06 Select button
- 07 Set button

Fig. 10 Digital Diesel remote control panel.

2.5 Technical Information

2.5.1 AC alternator

The tri phase synchronous alternator is directly coupled, one bearing, brushless, rotating field design, 12 wire, four pole (1500 RPM) and regulated by an Automatic Voltage Regulator (AVR).

The exciter stator has a residual magnetism, which guarantees self-exciting of the generator on start-up (that thereby generates a residual voltage of about 10% nominal voltage).

The AVR, powered by an auxiliary circuit on the main stator, acts on the exciter stator indirectly controlling the field generated by the main rotor by means of the sequence exciter rotor - diode bridge - main rotor.

The voltage regulator controls and keeps constant the average voltage of one phase. The voltage setting on the AVR can be adjusted with the help of a trimmer "V" between 185 and 290 Volts. (See par. 5.3.1)

A frequency control progressively deactivates the machine when the drive motor speed drops below a pre-set, adjustable threshold preventing over-excitement at low operating speeds and abating the load engage effects on the engine.

The AVR works only within limits of the set frequency 50 Hz. When operating below the lower limit of 46 Hz \pm 1 Hz the AVR will stop regulating to avoid overloading the exciter coil (This setting can be changed with trimmer "UF"). (See par. 5.3.1)

When applying the generator set at 60 Hz the AVR is re-adjustable as well. To operate at 60 Hz the engine RPM and Digital Diesel Control settings must also be changed. For the USA market a dedicated manual (Art. No 50200444) is available for 60 Hz applications. Please refer to the WhisperPower service centre for specific instructions to convert the generating set to 60 Hz.

A further option is to readjust the stability of the regulator. In the event of very irregular (alternating) loads it could be necessary to change this setting with the help of trimmer "S" to avoid interference of the regulator and the alternating load. In conclusion the regulator reaction time can be modulated to eliminate any voltage instability that may arise. (See par. 5.3.1)

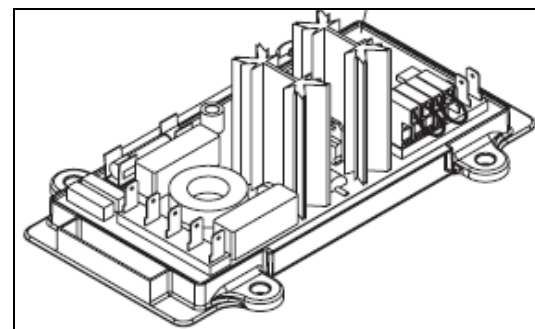

Fig. 11 Automatic Voltage Regulator (AVR).

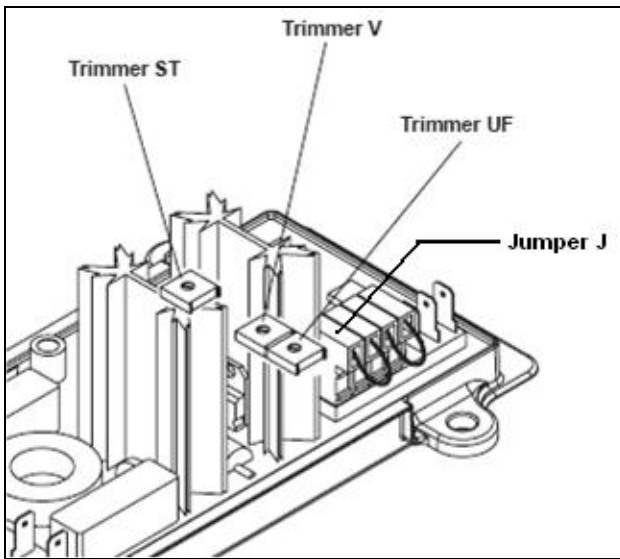

Fig. 12 AVR Trimmers (potentiometers).

The power comes from 12 wires that can be connected in star, delta or combined double / star and double / delta arrangements to take off different voltages. For tri phase 400V use, the alternator should be connected in star. For single voltage 230V use the wires should be connected in double delta. The alternator is specially designed that in this way one can take off the full power off the generator. However the use of three groups of 230 V taken from the three corners of a single delta arrangement is recommended. Other voltages (115 Volt) can be arranged as well. Further technical data on the connections of the alternator can be found in drawings and diagrams in this manual.

The tri phase synchronous alternator is directly coupled, one bearing, brushless, rotating field design, 12 wire, four pole (1500 RPM) and regulated by an Automatic Voltage Regulator (AVR).

Residual magnetism causes a small voltage over the stator windings and allows a current to flow in the windings, which is magnified because of the feedback effect between rotor and stator. The field windings in the rotor are short-circuited over a diode to rectify the current. A capacitor over an additional winding in the stator which is at an angle with the power-winding keeps the voltage stable within 5 % at the specified rpm and provides voltage fall off with speed, preventing over-excitation at low engine speeds and softening the effect of load switching to relieve the burden on the engine.

Further technical data on the design of the alternator can be found in drawings and diagrams in this manual.

2.5.2 Engine

The M-SQ20 / 25 generating set is based on the Mitsubishi S4S 4 cylinder 4 stroke diesel engine. The engine is indirectly injected. The engine is water cooled and the cooling liquid is cooled by a heat exchanger and raw (sea) water. The heat exchanger and all other parts which are in direct contact with the raw (sea) water are made of seawater resistant material like naval brass and copper nickel.

The engine has been specially adapted for the WhisperPower application and is very different from the standard engine supplied for industrial applications!

2.5.3 Digital Diesel Control system

The standard electrical engine control system is 12 Volt negative earth, non earth return (ungrounded) is available as optional. Check your identification data to determine which system is applied. The system is designed according to the "energise to run" system. The Digital Diesel Control is a very advanced microprocessor based full automatic system. Besides automatic start the system offers many monitoring options. See the separate Digital Diesel Control users manual (number 50200261).

The microprocessor unit of the Digital Diesel Control is located in the black box on top of the AC alternator (see figure 5).

2.5.4 Battery charger

On the engine is an alternator generating 50 Amp 12V. This current is rectified to charge the battery. The voltage is regulated at approx. 14.4V.

2.5.5 Alarms and shut down

In case of malfunctioning this will be indicated by the failure light, details will be shown on the display and the engine will be shut down. There are three functions guarded: oil pressure, oil temperature and exhaust temperature.

Exhaust temperature too high indicates the cooling water to be blocked.

All alarm switches are closed when no malfunction occurs. A contact is cut in the event of an alarm. This means that the generating set will not work when the alarm switches are broken or there is a loose wire. The system therefore is intrinsically safe. The panel will display details about the alarm.

2.5.6 Monitoring

Refer to the operating of the Digital Diesel Control

2.5.7 Control

The generating set can be operated by push buttons on the panel on the alternator or by the remote control. By pushing the START button the control system is activated and will start the engine automatically. Pushing the STOP button will stop the engine and the electrical system will be deactivated. Stopping the engine is executed by the solenoid that will shut off.

2.5.8 Remote control

All wiring connections from the remote control to the board are made by plug in connectors.

An intermediate communication cable is in the standard supply. If necessary an optional longer 8 wire communication cable can be connected if the standard length does not suit the required distance. Numerous remote control units can be put in parallel by using the connectors on the back of the units. (See installation instructions)

2.5.9 Hour counter

The remote control offers several timer functions that help to schedule maintenance.

2.5.10 Load indicator

On the remote control the load will be indicated on the display and by the LED-bar. The load is measured by current transformers on the alternator. All phases are monitored and overload of all phases or just one or two phases will provoke an alarm or even shut down when the alarm is ignored.

2.5.11 Fuel specification

The engine must only be used with diesel fuel oil which conforms to the standards for use in modern diesel engines. Fuel free from water and contaminants is of the utmost importance.

2.5.12 Oil information

1 Specification:

The oil must be suitable for oil changes as specified in the maintenance chapter. The Mitsubishi engine must be run on heavy duty lubricating oil meeting the requirements of API class CD, CF or CF4.



It is very important to use the correct oil specification. Very often local oil suppliers recommend a higher class, because they assume that a higher class is allowed. This is not the case. One should not follow these

recommendations. Using the wrong specification will cause high oil consumption.

2 Oil viscosity:

We recommend a multigrade oil 15W40.

3 Oil capacity:

Excluding the oil filter the content of the crankcase is 9 l. Including the oil filter it is 9.3 l. Note that the engine may contain some residual oil due to testing at the factory.

While filling, check the lubricating oil level by means of the engine oil dipstick. Do not overfill with lubricating oil as this may have a detrimental effect on engine performance.

4 Oil pressure

- Minimum at idle 98 kPa (1 kgf/cm²/14psi) (1 bar).
- At 2230 rpm \pm 300 kPa (3 kgf/cm²/45 psi) (3 bar).

2.5.13 Cooling liquid

The engine is cooled by cooling liquid. The capacity of this system of the M-SQ20 / 25 is 9.5 litres.



Always use coolant which is compatible with aluminum components of the cooling system. Do not mix coolants with different kinds of chemical compound, as this may cause congelation of the coolant. In case of doubt refresh the content of the entire cooling system.

We recommend not using water but cooling liquid that is marketed for the use in combustion engines. Cooling liquid protects the engine against frost to minus 25° C. Also it protects the engine block against corrosion. One can fill the engine via the filling cap on the exhaust manifold. Fill up till the level is just below the filling cap. When the engine is on temperature the liquid will expand and the redundant liquid will be pressed into the expansion tank. This tank has to be filled up till the mark. When cooling liquid is not available clean fresh water could be used with an additive of anti freeze. When using water with anti freeze the right mixture has to be calculated according to the information of the supplier of the anti freeze. When the cooling is based on keel cooling or radiator cooling the capacity of these coolers and piping has to be taken into account calculating the right mixture.

The cooling liquid in the engine is pressurised and has a boiling point above 100° C. The temperature switch in the thermostat housing switches at 110° C. When keel cooling is applied the cooling system is not pressurised. There should be a special cap on the manifold without valves leaving the connection to the expansion tank open. See the special manual on keel cooling and radiator cooling.

2.5.14 Technical data

GENERAL

Model	M-SQ20 / 25
RPM	1500 rpm
Alternator	3 phase synchronous (air cooled)
Engine	Mitsubishi diesel, model S4S (Japan)
Number of cylinders	4
Displacement	3331 cm ³
Bore X stroke	94x120 mm
Combustion air consumption	10 m ³ /min.
Continuous power 50Hz	25 kW electric power
Cooling system	indirect cooling by raw water, 20-25 l/min.
Cooling water pump	PTO driven WhisperPower self priming impeller pump, type M16
Fuel lift pump engine	Mechanical pump, additional electrical pump available upon request
Starting battery (optional)	110 Ah 12V
Fuel consumption	2-9 litre/hour, load dependent
Control	Digital Diesel Control including automatic start/stop

ELECTRICAL SPECIFICATIONS

Output voltage	230/400V 50 Hz alternating current (AC) tri phase re-connectable to take off single phase or dual voltage
Output rating 50Hz	25kVA at powerfactor cos phi = 1
Voltage tolerance	± 2% (balanced load)
Frequency tolerance	± 3%
Alternator	Air cooled, brushless, four pole, twelve wire, synchronous
Voltage regulation:	AVR

MECHANICAL SPECIFICATIONS

Supply includes	Sound shield with steel base, mounted on rubber anti vibration mounts. (Genset without sound shield is optional)
Dimensions in sound shield hwxwd	126x68x80 cm
Dimensions without sound shield	115x60x75 cm
Color:	metallic silver / grey
Weight with sound shield	580 kg
Weight without sound shield	480 kg
Max. operation angle	25 degrees
Standard supplies	Remote panel (+15 m cable), fuel filter, fuel lift pump, user and installation manuals
Optional	Installation kits, mobile (vehicle) version, non earth return, spare part kits, PTO to drive hydraulic pump

2.5.15 Electrical diagram control wiring M-SQ20 / 25

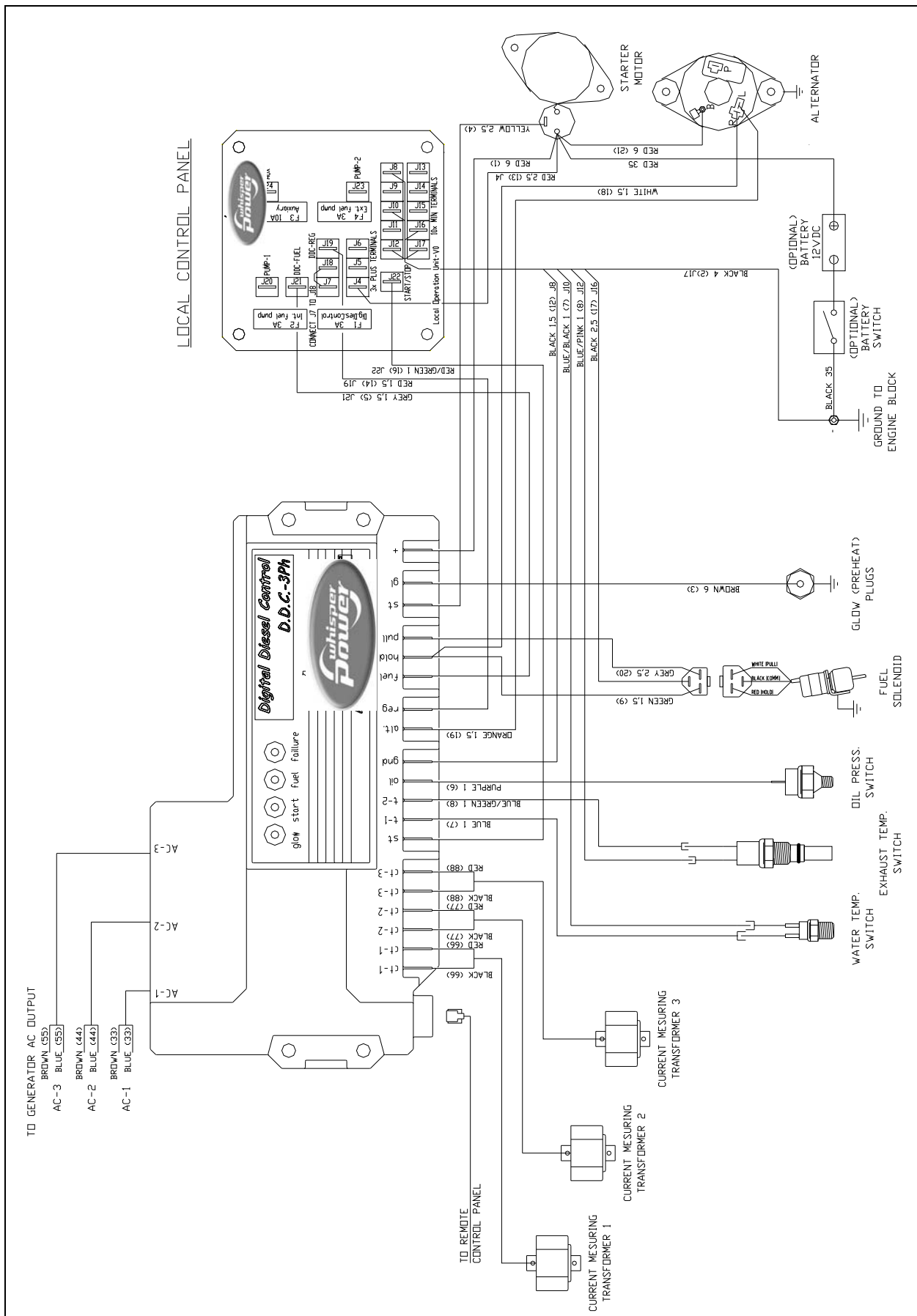

Fig. 13 Electrical Diagram control wiring M-SQ20 / 25

2.5.16 Terminal modes 115VAC – 230VAC - 400VAC 50H

Fig. 14 Terminal modes

2.5.18 AC Wiring Diagram single phase with AVR 230V Hz (Double Delta)

Fig 16. AC Wiring Diagram single phase with AVR 230V Hz (Double Delta)

3 OPERATION

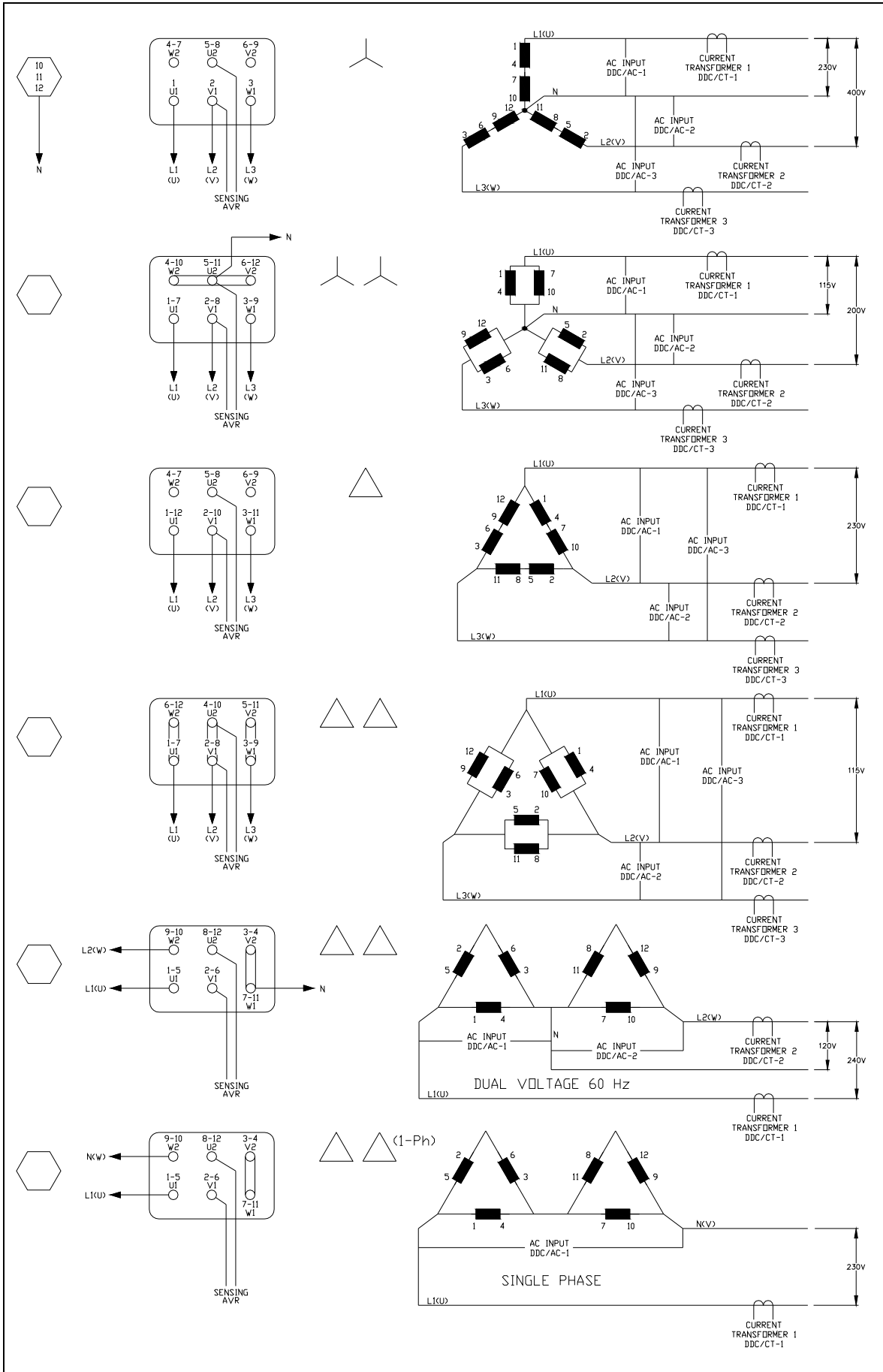
3.1 General

The generating set is operational after full installation and filling up with: fuel, engine lubricating oil and cooling liquid, filling the starter battery with acid (WhisperPower batteries do not need to be filled up and are sealed), connecting the remote control panel.

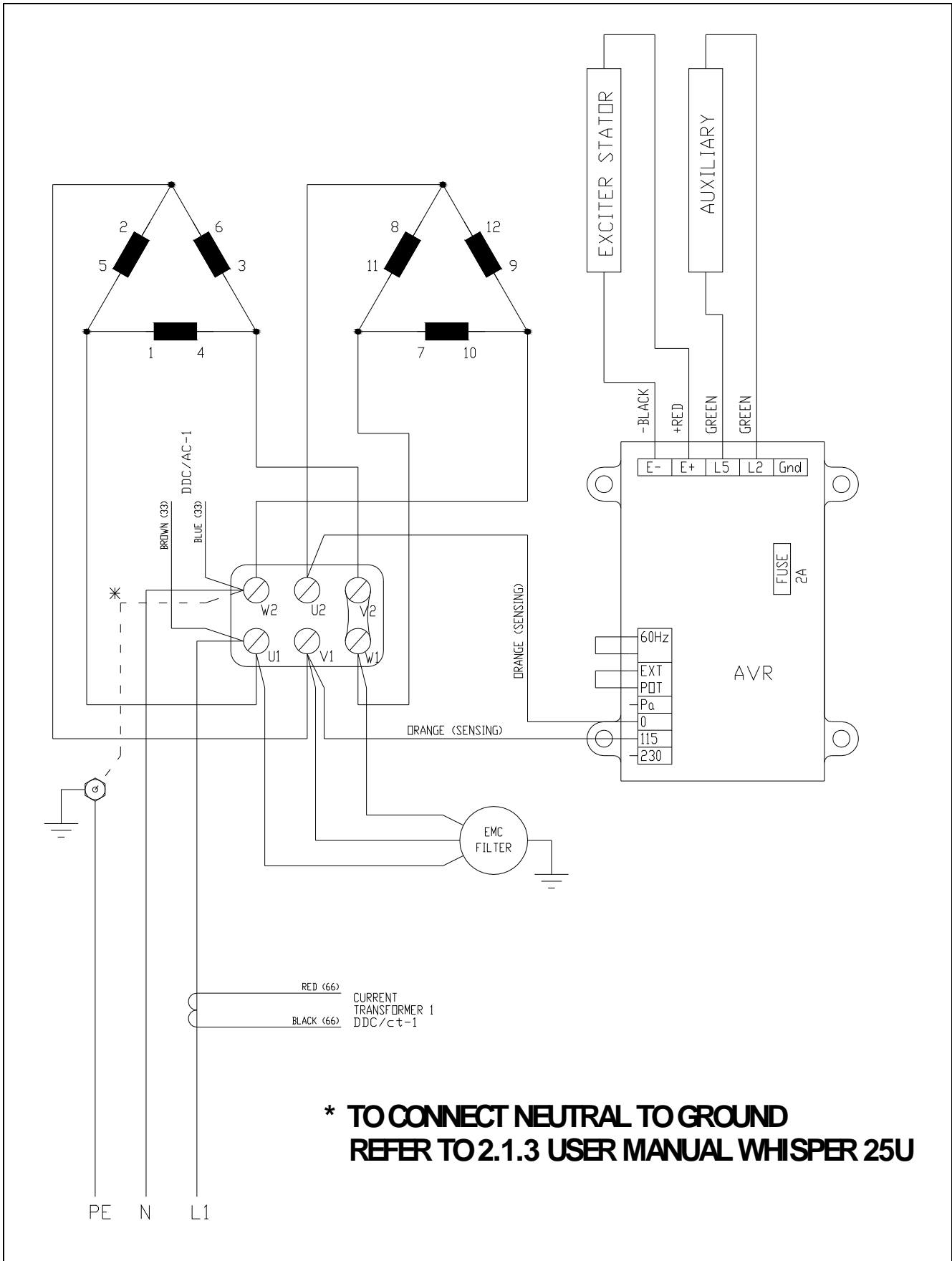
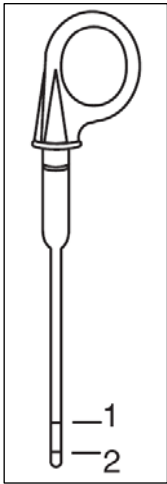

1 Max. oil level;
2 Min. oil level.

Fig. 17 Engine Oil Dipstick markings.

3.2 Operating Instructions

3.2.1 Summarised operating instructions (daily use)

Routine "pre-start" checks:

- 1 Check oil level.
- 2 Water inlet (all valves open).
- 3 Power source selector switch (off/shore power/generator power). Switch to power source switch "OFF", or switch off all consumers in the usual way. If a Masterswitch is installed, this is operating automatically.
- 4 Switch on battery switch (when installed).
- 5 Fuel valve: open.

Starting:

Push the start button to initiate the full automatic starting procedure. You can monitor the procedure on the display.

In operation checks:

- 1 Check for abnormal noise or vibration
- 2 Check the voltage
- 3 Check sea water flow at exhaust outlet
- 4 Power source selector switch (off/shore power/generator power). Switch to power source generator. If a Masterswitch is installed, this is operating automatically.
- 5 Before loading the generating set up to maximum, have it run warm. Continuous load should be restricted to 70 % of maximum load.

Stopping generator:

- 1 Switch off all electrical devices (consumers). If the generating set has been running under full load for a longer period, do not shut it down abruptly. Reduce the electrical load to about 30% of the rated load and let it run for approx. 5 minutes.
- 2 Press the STOP button.
- 3 Close the inlet sea water cock.
- 4 Switch to another 230V/400V power source, if available. If a Masterswitch is installed, this is done automatically.

3.2.2 Extended operating instructions

Check when starting the first time or after a longer period of rest:

- 1 If there is any damage caused by transport or installation.
- 2 Check if installation conforms to the installation instructions.
- 3 Ensure the generating set is free to turn without obstruction.
- 4 Check all hoses and hose connections for leaks.
- 5 Check all cables and cable end terminal connections.
- 6 Check the engine and generator mounting bolts.

Routine "pre-start" checks:

- 1 Check engine oil level.

The generator switches off in the event of insufficient oil-pressure. Even when the oil level is too low the oil pressure can be high enough. Do not run the generator with the oil below the lowest mark in the, because a smaller volume of oil will become contaminated considerably quicker than a larger volume. Therefore we recommend daily oil-checks.

Check oil level prior to starting the engine or at least 5 minutes after the engine has stopped.

- 2 Check sea water cocks. Do not forget the valve of the water outlet in case of a water/exhaust gas separator.
- 3 Check the water strainer.
- 4 Check for leakages.
- 5 Regularly check the siphon vent in the cooling water supply.
- 6 If no Masterswitch is used: Switch main Power Source Selector switch to "OFF" or switch off all devices.
- 7 Switch on the battery switch.

Starting the generator:

By pushing the start button briefly the electric system is activated and the starting procedure will begin. (By pushing the stop button the system is deactivated)

The first time starting up or after running out of fuel it could be necessary to prime the fuel system. (See bleeding fuel system instructions in the maintenance chapter).

A restart protection prevents starting the engine when it is already running, which could cause damage.



In the event of starting problems (numerous attempts are made), close the sea-water inlet cock while cranking to prevent the outlet system and engine to fill up with water.

During the starting process, the cooling water pump is driven with the engine. The cooling water is discharged to the exhaust outlet, because the engine does not run, the exhaust pressure is not high enough to expel this water.

Open the valve immediately when the engine starts in order to prevent damaging the impeller.

Water in the cylinders will cause serious damage to the engine. For instance; a bent piston rod or a cracked cylinder head. In fact water in the cylinder is the main cause for engine damage in pleasure craft.

Checks once the generator is in operation:

- 1 Check for abnormal noise or vibration.
- 2 Check the voltage.
- 3 Check coolant flow.

Always check immediately after starting the generator if cooling water flows at the exhaust outlet. If this is not the case, check the cooling water pump. After having become acquainted with the generator you will be able to recognise the coolant flowing through the system by listening for the noise of the water which is expelled.



Be aware that especially in harbours the coolant water inlet can easily be blocked by floating objects.

- 4 Power source selector switch (off/shore power/generator power). Switch to power source generator. If a Masterswitch is installed, this operates automatically.

Before loading the generating set up to maximum, have it run warm. The first 50 hours of running the continuous load should be restricted to 70 % of maximum load. Running for long periods at no load or light load in the first 50 hours can cause cylinder glazing and high oil consumption.

Engine load during longer operation:

Please ensure that the generating set is not overloaded. Overloading occurs when the electrical load (demand) is so high that the generator cannot be turned around properly by the diesel engine. Overloading causes the engine to run rough, while using oil and excessive fuel and producing soot by the exhaust. The engine can even stop.

The generator should therefore only be loaded at the maximum rated power for short periods (2-3 hours) only!

The high peak current is meant for the ability to start electrical devices that need a high current for starting especially electric motors and compressors (from a still stand state).

In order to prolong the generating set's life expectancy, the nominal electrical demand on the system should be about 70% or the rated generating set's maximum load. Please note this when switching on your electrical devices!

Nevertheless, the Whisper is designed so as not to overheat, even under extreme conditions.

Do not run the generator for very long periods at no load or at very low load. When this is necessary do load the generator at least one hour in 10 hours for minimum 70%. Long term running at too low load will cause the exhaust to be choked by carbon.



Never remove the battery while the engine is running or any electrical cable while the battery is connected in the circuit. Only disconnect the battery with the engine stopped and all switches in "OFF" position

Stopping the generating set:

- 1 Avoid stopping of the generator abruptly after a long period of operation at high load! Doing so, you avoid unnecessary thermal load to your generating set!

Act as follows:

Prior to switching off the generating set, decrease the generator load (i.e. turn off most electrical users) and let the generator run at low load for approx. 5 minutes to allow the engine to get properly cool (the influent sea water must flow through the system in order to cool the engine).

If the generator is operating in a hot environment and you do not act as given above, the excessive heat in the engine can trip the "high temp" alarms. In that case, a restart of the engine is not possible for some time. It is also recommended to switch off electrical users prior to stopping the generator because of the voltage drop that occurs as the engine comes to a halt. Such voltage drops may cause damage to electric motors, compressors (in refrigerators or air conditioners etc.).

- 2 Press the STOP button.
- 3 Close the inlet sea water cock.
- 4 Switch to an other 230V/400V power source, if available. If a Masterswitch is installed, this is done automatically.



If the engine is not running and 'failure' and 'charging' LED is blinking, reset by stop button, otherwise it will drain the start battery

4 MAINTENANCE

4.1 Alternator

The alternator does not require any maintenance. Periodic inspection and cleaning is recommended, depending on environmental conditions.

However when the alternator has been idle for a long period attention to winding condition is recommended.

The condition of windings can be assessed by measurement of insulation resistance to earth. (See 5.3.5 Meggering)

The alternator bearing is greased for life and is therefore not regreasable

4.2 Engine

4.2.1 Preliminary instructions

All regular maintenance can be carried out when the enclosure is open. When oil and dirt has gathered in the enclosure measures have to be taken to avoid spilling oil and polluting the environment.

The first service on the engine should be carried out after 50 hours of its life and after a major overhaul. In the first 50 hours the engine should receive special attention:

Long periods of light or no load running in the first 50 hours may lead to cylinder glazing and high oil consumption.



For the same reason it is of the greatest importance to use the right oil specification.

The first time starting up or after running out of fuel it could be necessary to prime the fuel system.

4.2.2 Bleeding fuel lines

Ensure there is sufficient fuel. The Whispers are self bleeding. To check the well functioning release the bleed screw on the high pressure fuel pump. Turn loose the cap of the fuel lift pump, and move the piston up and down to prime the system. Retighten the bleed screw when no further air bubbles are expelled. Retighten the cap when ready.

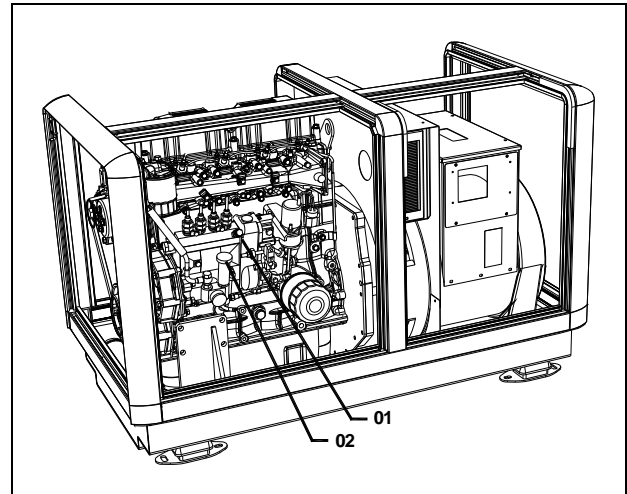

01 Injection pump air bleeding screw

02 Hand operated fuel lift pump

Fig. 18 Bleeding fuel lines.

4.2.3 Valve clearance

When the engine is in cold condition both valves (inlet and outlet) should have a clearance of 0.25 mm. The adjustment has to be done at TDC (see 5.4.2).

4.2.4 Replacing fuel filter

Filter change depends on contamination of the fuel, but should be done however, at least every 300 running hours. A clogged filter results in a lack of output of the generating set.

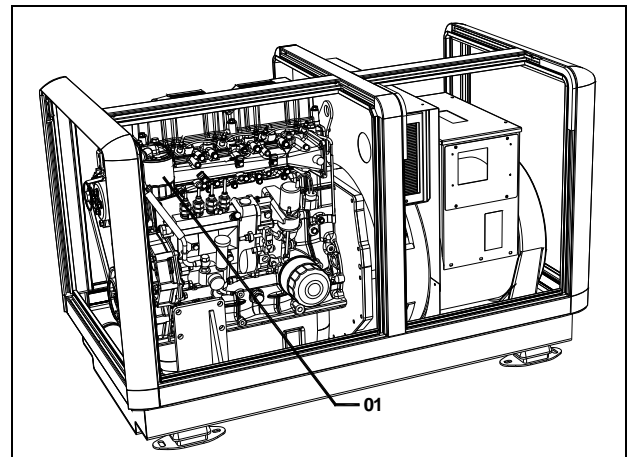

01 Fuel filter

Fig. 19 Location fuel filter cartridge

4.2.5 Replacing oil filter

Replacement has to be executed according to the schedule in this manual. Drain the oil using the sump pump and put some tissues under the filter.

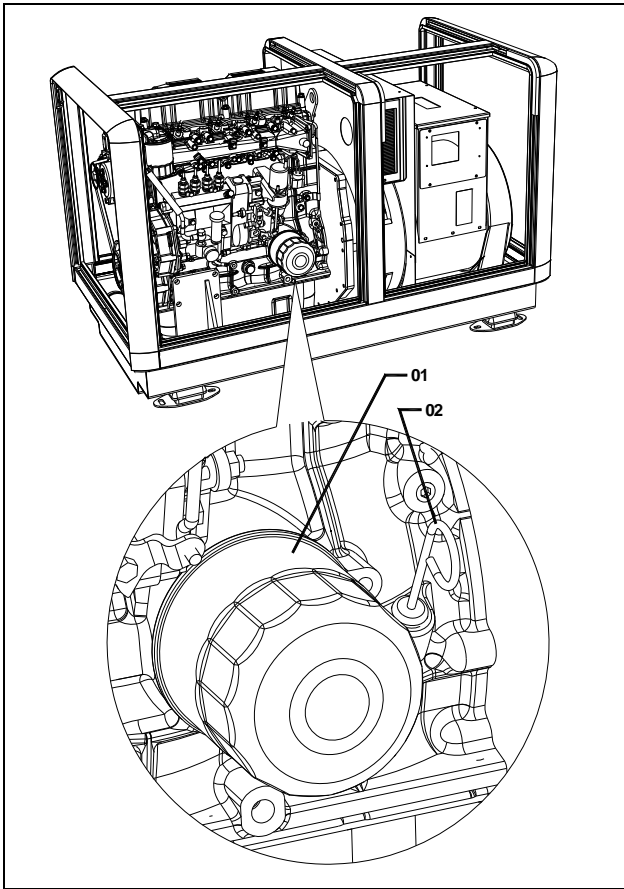

- 01 Engine oil filter
- 02 Engine oil dipstick

Fig. 20 Location engine oil filter and dipstick.

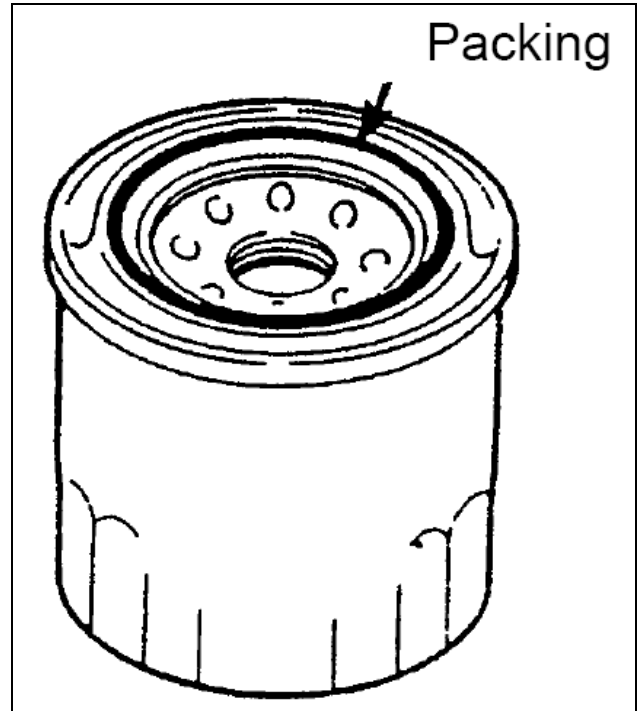

Fig. 21 Location rubber packing-ring oil filter.

A smear of oil has to be put on the seal of the filter before fitting the filter. The filter should be fastened manually: when the rubber touches the metal turn 3/4 further.

4.2.6 Tensioning V-belt

The alternator bracket allows for readjust of the V-belt. Deflections should be 13 mm (see fig. 22)

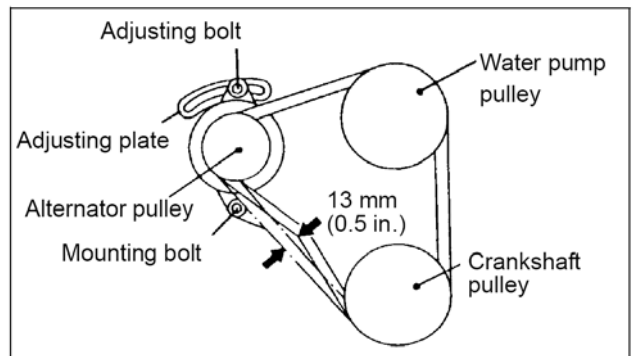

Fig. 22 Tension V-belt.

4.3 Regular maintenance

CHECK DAILY:

- Oil level

Take care the oil level is never below the mark. Do not add oil when the level is still above the mark.

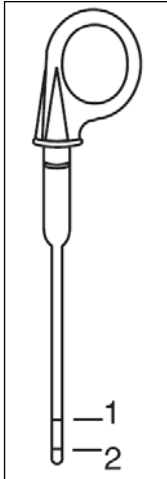

- 1 Max. oil level;
2 Min. oil level.

Fig. 23. Engine oil dipstick markings

- Level cooling liquid
- Hoses for loose connections or deterioration.
- Water inlet filter.
- V-belt tension

AFTER FIRST 50 HOURS:

- Change oil and replace the oil filter.
Have the engine run until it is on temperature and stop it. Replace the filter. Drain oil by the sump pump into a suitable retainer and fill up with fresh oil. Start the engine again and have it run for 5 minutes. Stop the engine again and pause for a few minutes to let the oil gather in the crankcase. Check the level again and add oil when necessary.
- Check and tighten nuts, bolts, and unions, paying particular attention to the fuel system.
- Observe the exhaust at the normal full load. The exhaust must be free from soot. Do not allow the engine to run with a dirty exhaust without investigating the cause as this may result in an expensive breakdown.
- Check air vent (siphon breaker valve) on a regular basis. When the air vent it not working properly, the engine can fill up with water by siphoning. Water in the combustion chamber causes serious damage to the engine.
- Check and readjust V-belt.
- Check the electrical connections

EVERY 150 HOURS:

- Change oil.
- Check the battery acid level (not for WhisperPower batteries).
- Check battery terminals for corrosion
- Check and readjust V-belt
- Check impeller raw water pump (durability depends on the purity of the sea water. In sandy water and warm water wear will increase).

When replacing the impeller the gasket between the pump case and the cover should be replaced as well. So when ordering a spare impeller order a gasket as well. Remove the cover to get access to the impeller. Remove the old impeller with the help of two screwdrivers. Install the new impeller and add some grease. Turn the blades in the direction of rotation of the pump.

EVERY 300 HOURS:

- Replace the impeller of the raw water pump.
- Retighten the cylinder head bolts and adjust the valve clearance. (See paragraph 5.4.2).
- Check air cleaner element.
- Replace the oil filter.
- Replace the fuel filter
Replacement depends on the condition of the fuel. We recommend replacement every 300 hours.

EVERY 1000 HOURS:

- Replace the V-belt.
- Retighten cylinder head bolts/adjust + check and adjust valve clearance.

EVERY 2000 HOURS:

- Check lubricating oil pressure
- Clean and check or replace fuel injector nozzles and check injection pressure.
- Check the air cleaner element:
The air is taken from the section between the alternator and the engine
- Check the cooling system:
The engine cooling liquid is indirectly cooled by raw water via a heat exchanger. The seawater is pumped by the PTO driven impeller pump. All parts of the cooling system are of corrosion free and seawater resistant materials such as naval brass and copper/nickel. In case of gathering of dirt in the system it could be cleaned by compressed air. When overhauling the engine one could clean the parts thoroughly or replace.

When the generator set runs less than 150 hours a year the oil should be changed yearly

4.3.1 Maintenance schedule

Check oil level	daily
Check water inlet filter	daily
Check the level of the cooling liquid	daily
Check hoses for loose connections or deterioration	daily
Change oil and oil filter	after first 50 hours
Check and tighten nuts, bolts, etc.	after first 50 hours
Check exhaust	after first 50 hours
Check air vent	after first 50 hours
Check and readjust V-belt	after first 50 hours
Check electrical connections	after first 50 hours
Change oil	150 hours
Check battery	150 hours
Check air vent	150 hours
Check and readjust V-belt	150 hours
Check impeller water pump	150 hours
Replace impeller water pump	300 hours
Retighten cylinderhead bolts and readjust valve clearance	300 hours
Replace oil filter	300 hours
Replace fuel filter	300 hours
Check air cleaner element	300 hours
Retighten cylinderhead bolts , adjust valve clearance	1000 hours
Replace the V-belt	1000 hours
Check lubricating oil pressure	2000 hours
Check injector and injection pressure	2000 hours
Check inlet air filter	2000 hours
Check cooling system	2000 hours

4.3.2 Taking out of service

When not using the generating set for a longer period it is recommended to execute an engine preservation procedure.

- 1 Clean the engine.
- 2 Loosen the fuel suction pipe and fuel return and put them in a can with preservation diesel fuel. Start the engine and run the engine warm.
- 3 Drain the hot engine oil and refill with preservation oil.
- 4 Stop the engine and take loose the inlet of the raw water pump. Drain the water from the water lock. Crank the engine having the raw water inlet sucking anti freeze from a can until the pump, heat exchanger and manifold are filled.
- 5 The coolant can stay in the engine
- 6 Disconnect the battery and store it in a place free of frost and dry and charge it regularly.
- 7 Close inlet- and outlet openings with tape.
- 8 Protect the generating set against the influences of bad weather conditions.

This method of preservation will be sufficient for 6 months. Change oil before using the engine again.

5 TROUBLE SHOOTING

5.1 Alternator/ electrical faults



CAUTION!

Remove 3 Amp. Fuse in the control panel while working on the generator to prevent the engine to start



DANGER!

Take care for parts which are live!

5.1.1 General

If any problem should occur, check basic conditions and examine all external wiring, switch gear and circuit breakers. Also check if measuring instruments give the correct value. If in doubt, measure directly on the alternator terminals with an independent instrument. This should only be carried out by an experienced electrician. If during these measurements the engine immediately stops after starting and an error code is displayed at the remote control panel ("AC VOLTAGE"), one can start the generator by means of a "service start" at the service menu (see paragraph "service start" of the user's manual of the Digital Diesel Control). By doing this, the generator will keep running for 2 minutes before it stops. This offers you

the possibility to carry out measurements to investigate the cause of the failure.

Check if the engine is running correctly at 1500 RPM (50 Hz) according to its settings and does as well under load. A RPM drop of 3% at full load is acceptable. Therefore a no load setting should be at 1545 RPM = 51.5 Hz. Under no circumstances should the RPM under full load be below 1485 RPM = 49.5 Hz.

When the problem is in the RPM refer to the engine fault finding paragraph.

Digital Diesel Control system will help to indicate failures and display causes.



CAUTION!

If the voltage is set any higher than its maximum limit, the generator may be damaged.

If the bottom speed is set at too low a frequency, the generator may be damaged. On the other hand too high a frequency can cause voltage drops with high loads.

A failure code is displayed when a hardware failure at the generator is detected.

<i>Failure code</i>	<i>Problem</i>
COMMUNICATION	Communication error between the panel end the generator
LOW START BAT	Starter battery voltage too low
ALTERNATOR	No output battery charging voltage
EXHAUST TEMP	Exhaust temperature is too high
WATER TEMP	Coolant temperature is too high
OIL PRESSURE	Oil pressure failure
LOW VOLTAGE	Generator AC output voltage is too low
HIGH CURRENT	Generator is in overload
FREQUENCY	Output frequency of the generator is too low

5.1.2 Trouble shooting table

PROBLEM	CAUSE	SOLUTION
No output (Voltage) at all	<ul style="list-style-type: none"> • Circuit breaker "off" or faulty main fuse • Faulty fuse of the AVR 	Check switches and fuses and measure directly on the alternator to exclude external causes. Check fuse of the AVR
	<ul style="list-style-type: none"> • Loss of residual magnetism 	Check the residual magnetism, temporarily increase RPM with 15%. Try to and flash the alternator (see special procedures)
	<ul style="list-style-type: none"> • Low engine RPM. 	Check the engine RPM and adjust (see special procedures).
	<ul style="list-style-type: none"> • Faulty RPM. 	Check by independent excitation if the problem is in the AVR or in the windings and replace if necessary (see special procedures).

PROBLEM	CAUSE	SOLUTION
	<ul style="list-style-type: none"> • Rotor diode broken. 	Check the diode in the rotor (see special procedures). The M-SQ20 / 25 has one diode block/rectifier unit.
Generator output voltage too low when no load is on it (less than 225V between phase and neutral).	<ul style="list-style-type: none"> • Engine is not reaching the rated RPM. • Faulty AVR. When slightly too low, adjustment could be necessary • Defective diode 	See special procedures to readjust RPM. Try to readjust AVR. Check by independent excitation if the problem is in the AVR or in the windings and replace AVR if necessary (see special procedures). Check the diode in the rotor (see special procedures). The M-SQ20 / 25 has one diode block/rectifier unit.
Generator output voltage too low under load (less than 225V). In no load condition it is OK	<ul style="list-style-type: none"> • When applying 3 phase: an unbalanced load; check the voltage of the other phases. When the voltages are different this is caused by an unbalanced load. • Engine is not reaching the rated RPM. Possibly too much load or engine problems (lack of fuel) • Faulty AVR or readjustment necessary 	Bring load in balance. When slightly out of balance, remove the sense wires to the phase with the highest load and check if the voltage on the other phases is not too high. Switch off a load; (part off) consumers See to engine RPM problems Try to readjust the voltage Check by independent excitation if the problem is in the AVR or in the windings and replace AVR if necessary (see special procedures).
Generator output voltage too high, (more than 235V)	<ul style="list-style-type: none"> • Over-energising due to defective AVR or wrong AVR setting 	Check AVR, readjust and replace if necessary capacitor specification and replace AVR if necessary (see special procedures)..
Generator output voltage too high, (more than 235V) In no load condition it is OK	<ul style="list-style-type: none"> • Unbalanced load 	Bring load in balance. When slightly out of balance, remove the sense wires to the phase with the highest load and check if the voltage on the other phases is not too low.
Generator voltage fluctuates.	<ul style="list-style-type: none"> • Disturbances on the electrical system/ user side. • AVR reacts on fluctuating load • Engine runs irregularly. 	Check if electrical load is fluctuating Readjust the stability setting on the AVR trimmer "ST" When engine runs irregularly see section: "Engine runs irregularly" at the "Engine faults" paragraph.
Generator is not able to start an electric motor	If the generator is unable to supply enough power to start an AC electric motor, this is usually because this motor draws too much current during starting As the alternator is very much under-rated the problem will appear by the engine RPM collapsing	Check the electric motor's current draw required for starting. This should not exceed the rated generator output current. This could be remedied by using a "soft-start". Inquire at your nearest WhisperPower dealer or directly at the manufacturer, WhisperPower in the Netherlands.

5.2 Engine faults



CAUTION!

Remove 3 Amp. fuse in the control panel while working on the generator to prevent the engine from starting.

5.2.1 General

Most electrical problems relating to Voltage or Frequency are due to wrong engine speed.

Note that RPM and Hz are basically the same.

Use the problem solving table to find the cause of a wrong engine speed. When there is no obvious cause one can adjust the RPM (see special procedures).

When the engine is not cranking well, starting problems almost always originate from battery problems or poor battery cable connections.

When the engine is cranking, well starting problems almost always originate from lack of fuel or air bubbles in the fuel pipes.



CAUTION!

When the engine does not start instantly, prolonged cranking can fill up the exhaust system with cooling water because of the water injected exhaust. When the water enters the cylinder through the valves this will

bring severe damage to the engine. When the engine does not start and repeated cranking is necessary shut off the seawater inlet. Open the valve immediately after the engine has started.

A failure code is displayed when a hardware failure at the generator is detected.

<i>Failure code</i>	<i>Problem</i>
COMMUNICATION	Communication error between the panel end the generator
LOW START BAT	Starter battery voltage too low
ALTERNATOR	No output battery charging voltage
EXHAUST TEMP	Exhaust temperature is too high
WATER TEMP	Coolant temperature is too high
OIL PRESSURE	Oil pressure failure
LOW VOLTAGE	Generator AC output voltage is too low
HIGH CURRENT	generator is in overload
FREQUENCY	output frequency of the generator is too low

5.2.2 Trouble shooting table

PROBLEM	CAUSE	SOLUTION
Diesel engine fails to crank, it does not react at all, or the starter makes clicking noises, or the engine cranks very slowly	<ul style="list-style-type: none"> • Almost certainly this is an electrical problem. One other possibility is that the engine is locked by water in the cylinders or there is other severe damage. Display will indicate "low battery voltage". 	Check on water in the cylinder and further damage by cranking. When there is water in the cylinder, then deactivate the control system, disconnect the battery, remove the glow plugs. Crank the engine to remove the water through the opening of the glow plugs. Check oil on the presence of water and change oil. Find out how the water did enter the cylinder (check the air vent). Take precautions to prevent it from happening again. When there is no mechanical malfunction the problem must be an electric malfunction.
No reaction at all	<ul style="list-style-type: none"> • Starter battery switched "OFF". • Faulty fuse on control panel 	Check position of the battery switch and switch "ON". Replace fuse
No reaction or clicking noises, or slow cranking	<ul style="list-style-type: none"> • Starter battery voltage insufficient (battery too weak). • To thick engine lubricating oil. • Starter motor faulty 	Check battery voltage. Recharge the battery. Inspect battery terminals and cables for a good electrical connection (inspect against corrosion, tattered wires, etc.) Change oil for a lower viscosity. Repair the starter motor
Starter is turning engine smoothly, but engine fails to start	<ul style="list-style-type: none"> • Out of fuel or faulty fuel, water in the fuel. • Fuel solenoid is not working. • Fuel lift pump is not working. • Fuel filter is blocked. • Air in fuel lines. 	Fill up with fuel or replace with better quality. Check if solenoid comes in; if not check wire connections and circuitcy to solenoid (see DC wiring diagram). Check fuel filter and fuel lift pump: clean or replace if necessary. Bleed air from fuel system (see maintenance section).



PROBLEM	CAUSE	SOLUTION
	<ul style="list-style-type: none"> • Wrong valve clearance. • Low compression because of dirty valves. 	Adjust valve clearance, Clean valves. Take off the injection bent and inspect the outlet port. When little rust in the port clean the valve by taking off the valve spring and rotate until clean. When the outlet port is strongly affected by rust, the exhaust system is not properly installed (see paragraph 5.4.3). Contact WhisperPower service department for advice.
	<ul style="list-style-type: none"> • Blocked injector. 	Have the injector tested and cleaned if necessary.
	<ul style="list-style-type: none"> • Loss of compression by wear out or damage 	Repair by WhisperPower service
Engine runs irregularly.	<ul style="list-style-type: none"> • Unsuitable contaminated fuel • Lack of fuel. • Choked fuel filter. • Disturbances on the electrical system/ user side. • Faulty fuel lift pump. • Choked air cleaner. • Lack of air. • Choked exhaust system, exhaust blocked, rubber exhaust hose kinked. • Air in the fuel pipes • Blocked injector. • Wrong valve clearance. • Temporarily hunting (this will disappear when engine has run in). 	<p>Fill up with fuel or replace by better quality.</p> <p>Check fuel filter and fuel lift pump: clean or replace if necessary.</p> <p>Check if electrical load is fluctuating.</p> <p>Try the pump by manual operation. Repair when faulty or replace</p> <p>Check the air intake</p> <p>Check the exhaust hose</p> <p>Bleed air from fuel system (see maintenance section).</p> <p>Have the injector tested and cleaned if necessary.</p> <p>Adjust valve clearance.</p>
Engine speed drops	<ul style="list-style-type: none"> • Too much oil. • Lack of fuel. • Lack of intake air. • Choked exhaust system, exhaust blocked, rubber exhaust hose kinked. • Generator overloaded • Defective generator (windings, bearings or other) • Damaged engine 	<p>Drain oil to proper level.</p> <p>Check fuel supply system: fuel pump and filter.</p> <p>Check air intake.</p> <p>Check exhaust system.</p> <p>Reduce the electrical load (switch off some consumers).</p> <p>Generator must be sent to manufacturer for repair of damaged bearing or winding.</p> <p>Repair by WhisperPower service</p>
Engine does not stop on command	<ul style="list-style-type: none"> • Fuel solenoid is not switching off • Loss of control 	Faulty Digital Diesel Control unit. Stop the engine manually by the stop handle. Check wire connections to fuel solenoid. Check solenoid function. Replace if necessary
Engine exhaust smokes	<ul style="list-style-type: none"> • Faint blue smoke - generally the result of light load • Heavy blue smoke - caused by lubricating oil: Overfull oil sump or worn cylinder bore, stuck broken or worn piston rings. • Black smoke –incomplete combustion caused by: Overload, choked air cleaner, inlet temperature too high, unsuitable fuel or water in fuel. 	<p>Increase load.</p> <p>Check the oil level. Check the compression.</p> <p>Check air cleaner Check the fuel . Check for overload.</p>

PROBLEM	CAUSE	SOLUTION
Engine starts, but stops after 10 seconds	<ul style="list-style-type: none"> Protection system stops the engine; this can be caused by oil pressure failure, lack of cooling water (exhaust temperature alarm). Overload, loose wire or faulty alarm switch. Digital Diesel Control will help to indicate failure. 	See paragraph 2.5.5. and 3.2.2 for information on the alarm system. Bypassing the switches can help to confirm the failure. When there is no real failure, it could be a faulty alarm switch
Engine stops by itself (Digital Diesel Control will help to indicate failures)	<ul style="list-style-type: none"> Overload or short circuit. Lack of fuel. Oil pressure low. (oil pressure switch tripped). Excessive heat in cooling system (thermo-switch tripped). Lack of cooling water (exhaust switch tripped). Impeller broken. Cooling water blocked. Water strainer blocked. Air or water in the fuel. Blocked air or fuel filter. Loss of compression by wear out or damage. V-belt broken or loose. Thermostat faulty 	<p>Switch off the consumers and test for short circuit.</p> <p>Check fuel supply system: fuel lines, pump, filter, valves, tank level, etc.</p> <p>Check oil level. Check engine's oil pressure and have it repaired by WhisperPower.</p> <p>Check cooling water system flow: water pump, inlet water filter, coolant flow.</p> <p>Repair by WhisperPower service.</p> <p>Readjust or replace V-belt</p> <p>Check thermostat and replace</p>
Sooty, black exhaust.	<ul style="list-style-type: none"> Generator is being overloaded. Digital Diesel Control will indicate "overload". Insufficient intake air. Choked air cleaner. Fuel injector faulty. Valve clearance incorrect. Poor fuel quality. Poor quality lubricating oil. Continuous running with very low load. 	<p>Check electrical load and switch off some consumers</p> <p>Check intake air paths and filter, clean and replace if necessary.</p> <p>Replace injector.</p> <p>Readjust valve clearance</p> <p>Use better quality diesel.</p> <p>Use better quality oil.</p> <p>Increase load and have the engine run for a few hours</p>
Loss of power	<ul style="list-style-type: none"> Wrong measurement. Check if the load is measured correctly. Does the Amp meter show the correct value? When calculating the load by multiplying voltage and amps this should be done by using the exact values, taking into account the power factor of the consumers. When any doubt, measure the power directly with an appropriate instrument. Overfull oil sump. Choked fuel filter. Choked air cleaner Exhaust blocked. Injector blocked. Loss of compression, sticking or damaged piston ring. Wear out of cylinder. 	<p>Bring the oil to the correct level</p> <p>Replace the fuel filter.</p> <p>Check air inlet openings; clean air cleaner.</p> <p>Check the exhaust system.</p> <p>Have the injector checked.</p> <p>Have the compression measured. Clean or replace the rings.</p> <p>Have the compression measured and have the engine overhauled.</p>
Over-temperature	<ul style="list-style-type: none"> Overload. Low level of cooling oil or air in the cooling system Water inlet system blocked. Broken impeller. Water strainer choked Heat exchanger choked. Faulty thermostat 	<p>Take away the overload.</p> <p>Fill up with liquid and release air bubbles. Check if there are air blocks in the system; see the installation manual</p> <p>Check the cooling system thoroughly.</p> <p>Check the thermostat or replace.</p>

Warnings



CAUTION!

Generator must be shut off immediately if:

- Motor RPM suddenly rises or drops.
- Unusual noise comes from generating set.
- Exhaust gases suddenly colour dark.
- Engine failure warning light is on.

5.2.3 Service address

If you cannot correct a problem with the aid of the malfunction table, contact your WhisperPower Service Centre or WhisperPower Netherlands, tel: INT+31-512-571550. www.whisperpower.eu.

5.3 Special procedures alternator

5.3.1 Automatic Voltage Regulator (AVR)

The voltage regulator has a $\pm 2\%$ voltage precision in the machine working range with distortion free loads.

The phase voltage can be adjusted by trimmer "V" (see figure 24) from 185 to 290V.

The regulator is equipped with a frequency dependant excitation limiter; the frequency can be calibrated by trimmer "UF", which is factory set at 46Hz (56Hz), ± 1 Hz. On reaching this frequency, the machine begins to reduce its voltage until it deactivates for very low frequencies.

A fuse protects the regulator and generator against overloads and/or faults; a pocket has been provided on the edge of the board to hold a spare fuse (rapid type 32x6.3 2A).

Another trimmer "ST" allows to adapt the regulator to the generator parameters.

The regulator has been built to suppress the voltage surges on releasing the load that are below 20% at nominal load.

AVR SETTINGS

To select the AVR settings access the control board after removing the cover. Most adjustments are factory set to ensure satisfactory results in the operating tests on commissioning. Further adjustments may be necessary to ensure optimum operation under specific working conditions.

If the alternator has to operate at 50Hz the jumper "J" across the terminals marked "60Hz" has to be left in place, if it has to operate at 60Hz this jumper should be removed. The output voltage can be changed by adjusting potentiometer "V". Take the generating set to its nominal speed and turn until the required voltage is obtained. If a small variation in speed causes a change in voltage, then

the bottom speed protection should first be calibrated. The voltage reference (orange wires) should be connected:

- to terminals "0" and "115" for an output voltage between 100 and 140V (factory setting)
- to terminals "0" and "230" for an output voltage between 200 and 280V.

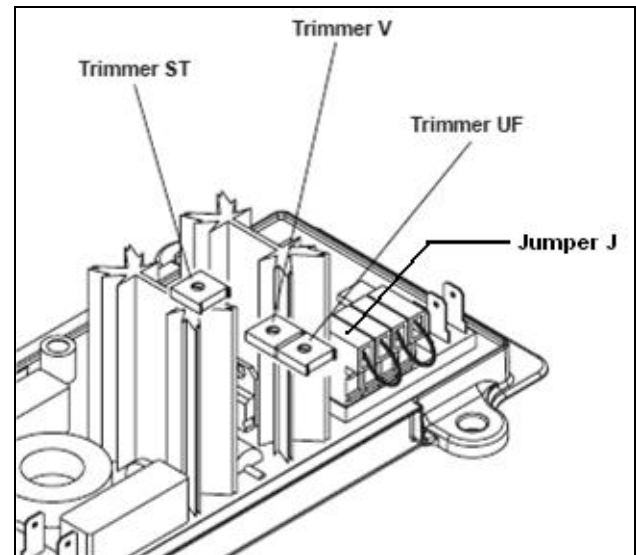

Fig. 24. Automatic Voltage Regulator (AVR)

To increase the range of available voltages by about 15% use terminal "Pa" instead of terminal "0". Caution: if the voltage is set any higher than its maximum limit the generator may be damaged.

Setting the bottom speed at 50 (60)Hz: start up rotation of the generating set adjusting it to obtain a frequency of 46 (56)Hz. Turn trimmer "UF" until the voltage begins to drop. Restore nominal speed.

Caution: if the bottom speed is set at too low a frequency the generator may be damaged. On the other hand, too high a frequency can cause voltage drops with high loads. If on load voltage fluctuations are experienced adjust potentiometer "ST", which modulates the reaction time of the regulator to external inputs, thereby eliminating any instability in the alternator-load system.

5.3.2 Residual voltage check / excitation procedure (flashing)

When residual magnetism disappears there is no residual voltage. Residual magnetism can disappear after the generating set being out of service for a long period or a short circuit. This can be solved by exciting the exciter field coil directly, disconnecting the AVR first. Put 12 Volt directly over the electronic regulator terminals taking polarity into account.

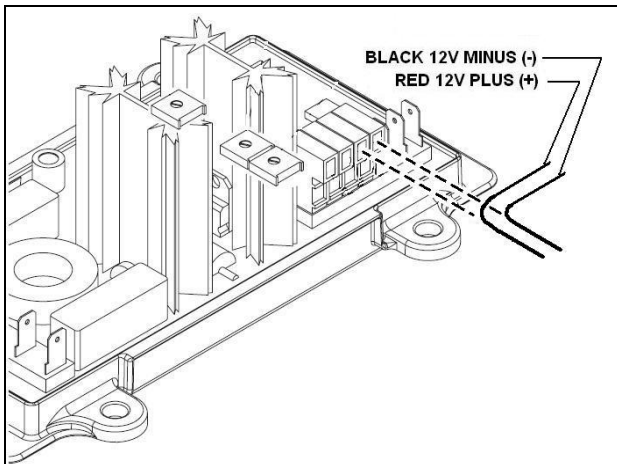

Fig.25 Residual voltage check / excitation procedure.

When using the starter battery fuse it and limit the current with a 30 Ohm resistor. Flashing can be done while the engine is running and the wiring is connected. When a variac (variable power supply) is available one should be able to control the voltage manually.



CAUTION

If the starter set battery is used for exciting one must take care. A short circuit can cause heavy sparking, fire and injuries.

When external excitation does not bring back voltage, the rotating rectifier diodes should be tested and a winding resistant test should be executed.

5.3.3 Testing rotary rectifier diodes

The diodes in the rotor can be checked with a multimeter. The diodes are integrated in a rectifier unit. When all diodes are faulty the alternator will not generate any voltage. When one or more diodes are faulty the alternator will produce too low voltage.

The flexible leads connected to the diodes should be disconnected at the terminal end, and the forward and reverse resistance checked. A healthy diode will indicate a very high resistance (infinity) in the reverse direction, and a low resistance in the forward direction. A faulty diode will give a full deflection reading in both directions with the test meter on the 10,000 ohms scale, or an infinity reading in both directions. In case of faulty diodes replace the

rectifier unit. One can get access to the diode unit by taking off the backend of the alternator.

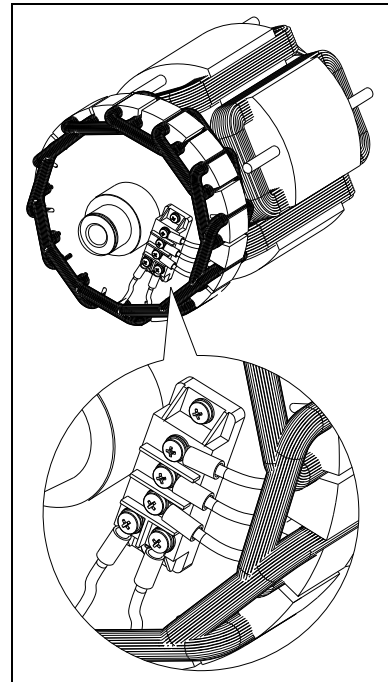

Fig. 26. Location rectifier diode block

5.3.4 Winding resistant values

If after establishing and correcting any fault on the AVR and diodes, and output is still low when separately excited, then the main rotor, stator auxiliary and exciter stator winding resistance should be checked as the fault must be in one of these windings. The respective leads must be disconnected before taking the readings.

Resistance values should be within 10% of the values given in the table below:

Resistance M-SQ20 / 25

• Resistance main stator windings	0.33 Ohm
• Resistance rotor windings	1.18 Ohm
• Resistance auxiliary winding	3.85 Ohm
• Resistance exciter stator winding	18 Ohm
• Resistance exciter rotor winding	0.18 Ohm

5.3.5 Meggering

One can try to measure resistance between the housing and the windings with a multimeter which should read infinity. When readings are infinity but a fault is suspected one can do a high voltage resistance test (MEGGERING) This procedure should be carried out by an expert. The AVR should be disconnected during this test. A 500V 'Megger' or similar instrument should be used. The insulation resistance to earth of all windings should be in excess of 2 MOhm. Should the insulation resistance be less than this value, drying out the generator windings is essential. Drying out can be carried out by direct warm air (60-80°C) from a fan heater or similar apparatus into the generator air inlets or outlets.

5.4 Special procedures engine

5.4.1 Setting the RPM

RPM is set by the manufacturer and should not need readjustment! However a very slight offset after running in could occur. RPM can be measured by a frequency meter. Before readjustment check any other explanation for the wrong speed. Engine speed is set at the factory at nominal 1500 (50 Hz) RPM. A RPM drop of 5% at full load is acceptable. Therefore a no load setting should be at ± 1575 RPM = 52.5 Hz. Under no circumstances should the RPM be under full load below 1470 RPM = 49 Hz. When no cause can be found for a wrong speed, the setting can be adjusted:

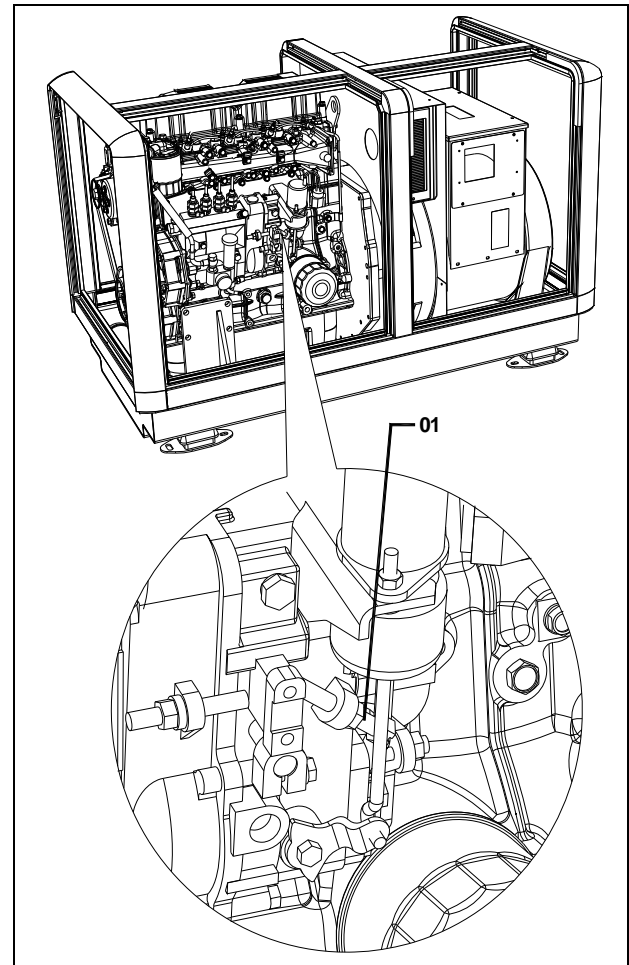

01 Engine speed adjusting screw

Fig. 27 Location engine speed adjustment screw.

It is very important to identify the correct setting assembly (see fig. 27). The screw is to be locked in position with the lock-nut.

5.4.2 Adjusting valve clearance and retightening the cylinder head bolts.

Both procedures have to be executed with a cold engine. When both procedures are executed be sure to retighten the cylinder head bolts before adjusting the valve clearance. When retightening the cylinder head bolts, drain the coolant by removing the coolant drain plug (ref. to fig. 4).

Loosen the bolts slightly, remove the rocker assembly (the rocker arms, shaft, and stays) and then retighten the bolts to the specified torque in the numerical order illustrated (ref. to fig. 28).

Tightening torque cylinder head bolt:	118 ± 5 Nm
Rocker stay tightening torque:	10-20 Nm

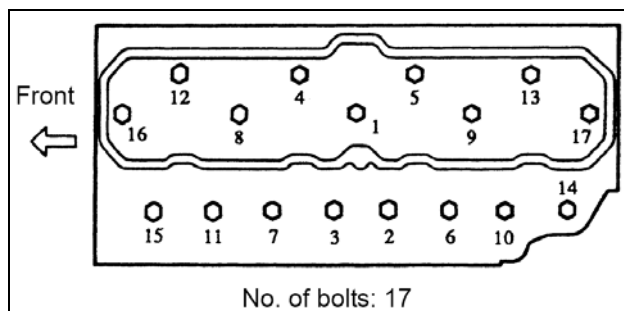

Fig. 28. Cylinderhead bolt tension sequence.

The clearance of both (intake and exhaust) valves should be 0.25 mm in cold condition. Set the piston of the first cylinder to be adjusted to top dead centre (T.D.C.) of compression stroke.

The T.D.C. of compression stroke can be found by aligning the T.D.C. mark "O" on the crankshaft pulley with the mark on the gear case

First align the T.D.C. mark for the No. 1 cylinder. Confirm that the valves do not move up or down when the crankshaft is turned about 20 degrees in normal and reverse direction of rotation.

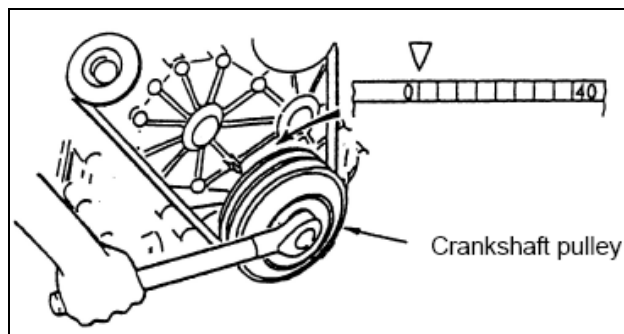

Fig. 29. Checking valve clearance (turning)

If the rocker arms move piston no.1 is on the T.D.C. of the intake or exhaust stroke. In such case turn the crankshaft

360° in the direction of engine rotation again. No. 1 piston is now at T.D.C. of the compression stroke.

After adjusting the valves of cylinder 1 adjust the valve clearance of the remaining cylinders in firing order 1-3-4-2 Turn the crankshaft 180° clockwise from the T.D.C. of cylinder 1 to the T.D.C. of cylinder 3. Adjusts the valves of cylinder 3 and turn the crankshaft further clockwise to the T.D.C. of cylinder 4 and finally to 2.

5.4.3 Measuring exhaust backpressure

The exhaust system must be of adequate size - 2 1/2" / 63 mm - and maximal length (see installation manual). When any doubt, backpressure has to be measured. An easy way to measure for back-pressure is to use a water column.

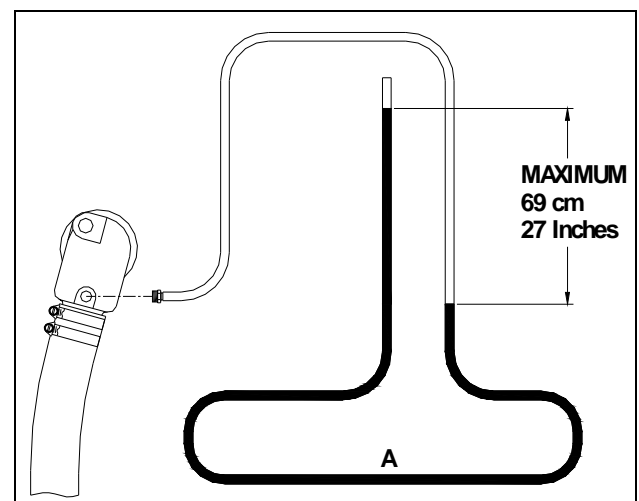

Fig. 30 Measuring exhaust backpressure.

A water column can be made visible in a plastic tube along a yardstick and fitting the end to a hose connection to fit in the adaptor on the injection bent after removing the exhaust temperature switch.

The bent A hanging down should not be too short helping to damp the pulsating effect of the gas discharge. The water column should be no more than 27 inches (69 cm.) of water (1 PSI - 0,07 bar)

5.4.4 Disassembling instructions

It could be necessary for repair or checks to disassemble the generating set.

Following instructions will help:

- 1 The design of the M-SQ20 / 25 makes it possible to do most repairs on the spot. The heat exchanger is accessible and can be removed. The connections of the alternator are very accessible as well.
- 2 The sound shield canopy can be disassembled according to exploded view below.

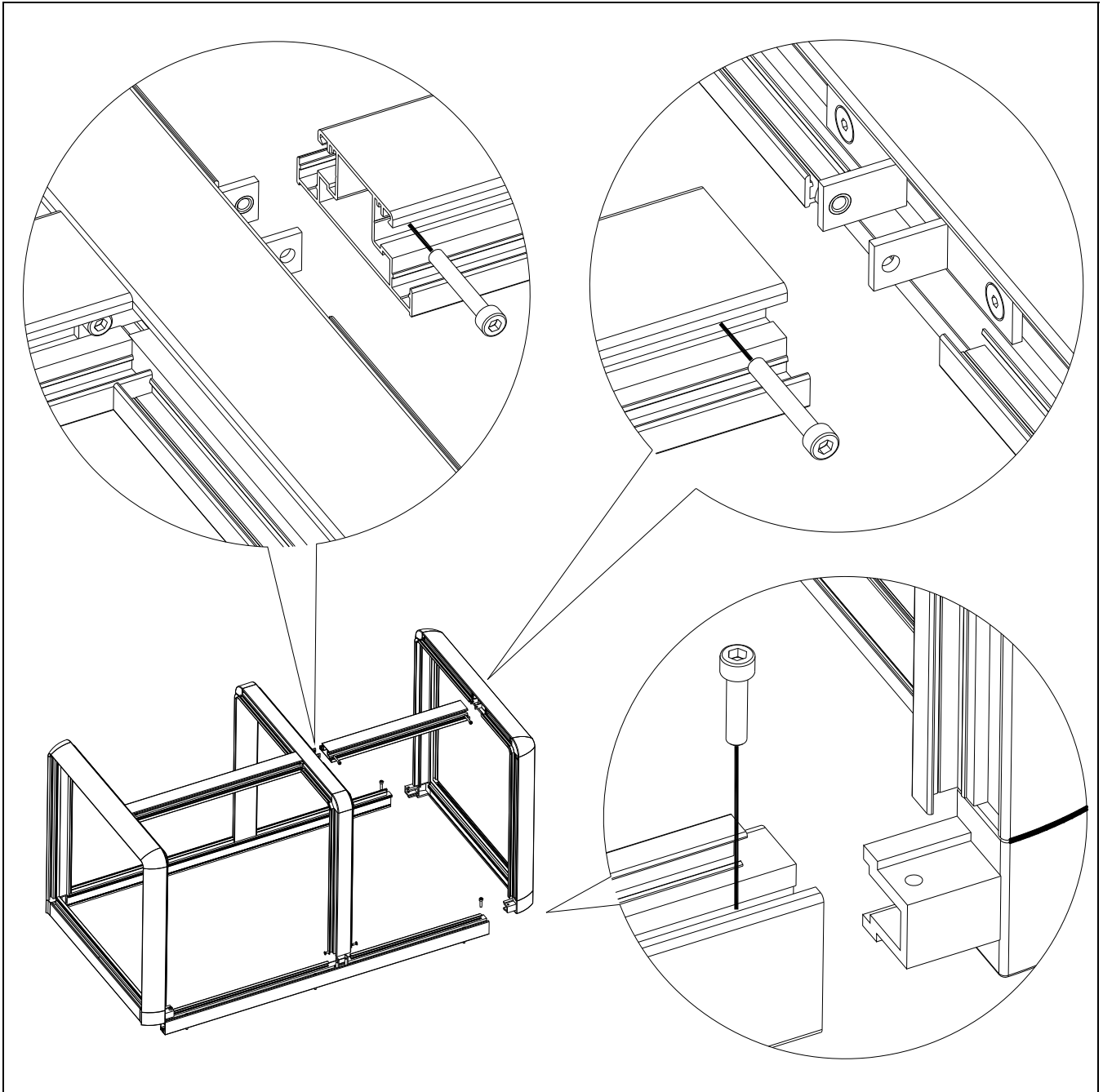

Fig. 31 Exploded view soundshield

- 3 To take the generating set out of the canopy all hose and cable connections have to be taken off. The set is fixed to its base by four rubber mountings and can be loosened by removing the four nuts from the bolts of these mountings. The easiest way to get the generator out of its capsule is by lifting the set with the aid of the lifting eyes
- 4 Taking the generator set from its mounting, or to replace a mounting can be done according to the drawing below
- 5 Reassembling the generating set one should take care of alignment, cleaning the surfaces between engine and alternator and tighten the bolts crosswise and gradually.
- 6 Test the generating set first outside its capsule and check very carefully for leakages before putting it back in its enclosure.

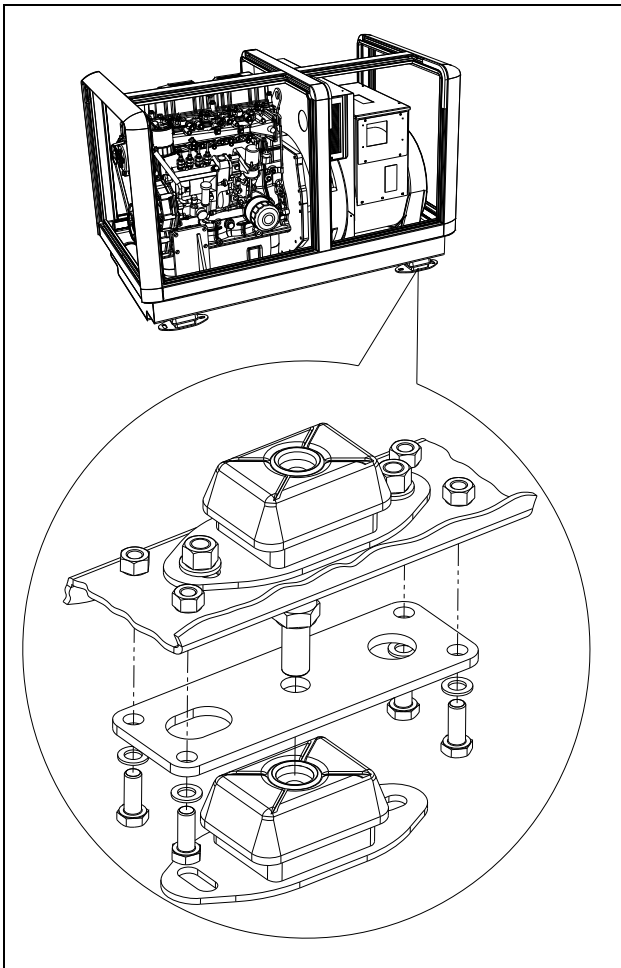

Fig. 32 Exploded view rubber mountings

6 SPARE PARTS

A complete parts manual in English is available as an option number: number: 40200187 (***)

A work shop manual in English is available as an option, number: 40200174 (***)

We recommend the following spares for service and maintenance.

- Kit A: parts for regular maintenance parts marked (*) article no. 40201560
- Kit B: parts for maintenance + spare parts: all parts marked (*)+(**) article no. 40201561
- Kit C: parts for "world travellers" all parts marked (*)+(**)+(***) article no. 40201562

ARTICLE NO	DESCRIPTION
40206122	Fuel filter (*)
50208120	V-belt (*)
40208121	Oil filter (*)
50230007	Air cleaner element (*)
50208186	Raw water pump complete WhisperPower type M25 (***) (see next pages)
40206254	Impeller + gasket (*) (8+15)
40201812	Cover type M16 (**) (10)
50209018	Bolts cover (**) (1) (6 pcs.)
40206257	Repair kit A. See next pages (**)
40206258	Repair kit B. See next pages
50201553	Heat exchanger complete with appendages (***)
50201551	Water hoses with clamps (**)
50209145	Measuring coil Wh 25, 3 pcs (***)
50208010	Rotary diode three phase (**)
50208015	Alternator bearing including O-ring (**)
50208020	Voltage regulator
40209161	Local control panel (***)
50209199	Digital Diesel Control Unit 3 phase (***)
50212170	Fuses 10 Amps(*)
50212154	Fuses 3 Amps (*)
50212197	Fuses 32 x 6.3 / 2 Amps (*)
50201559	Wiring loom complete (***)
40209102	Digital Diesel Remote control panel (***)
50209133	Cable remote control 15 mtr, including connectors
50208033	Overhaul gasket kit / Seal kit (***)
50208030	Cylinder head gasket kit
50206040	Glow plug, 4 pcs (**)
50208050	Nozzle injector, 4 pcs (**)
50206045	Thermostat (**)
50206038	Gasket thermostat (**)
50208034	Gasket rocker cover (**)

More extensive parts list on the internet: WHISPERPOWER.EU (fast moving parts)

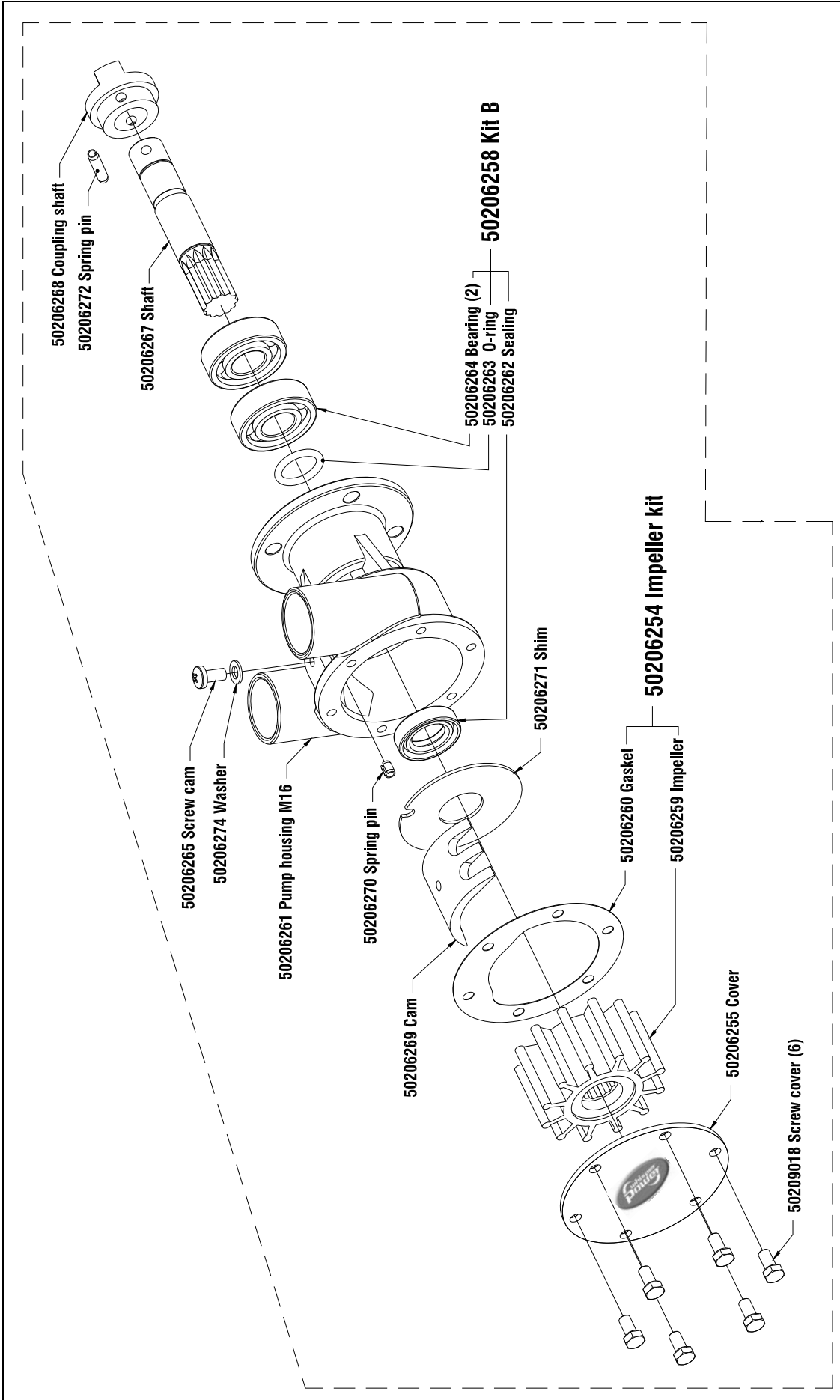

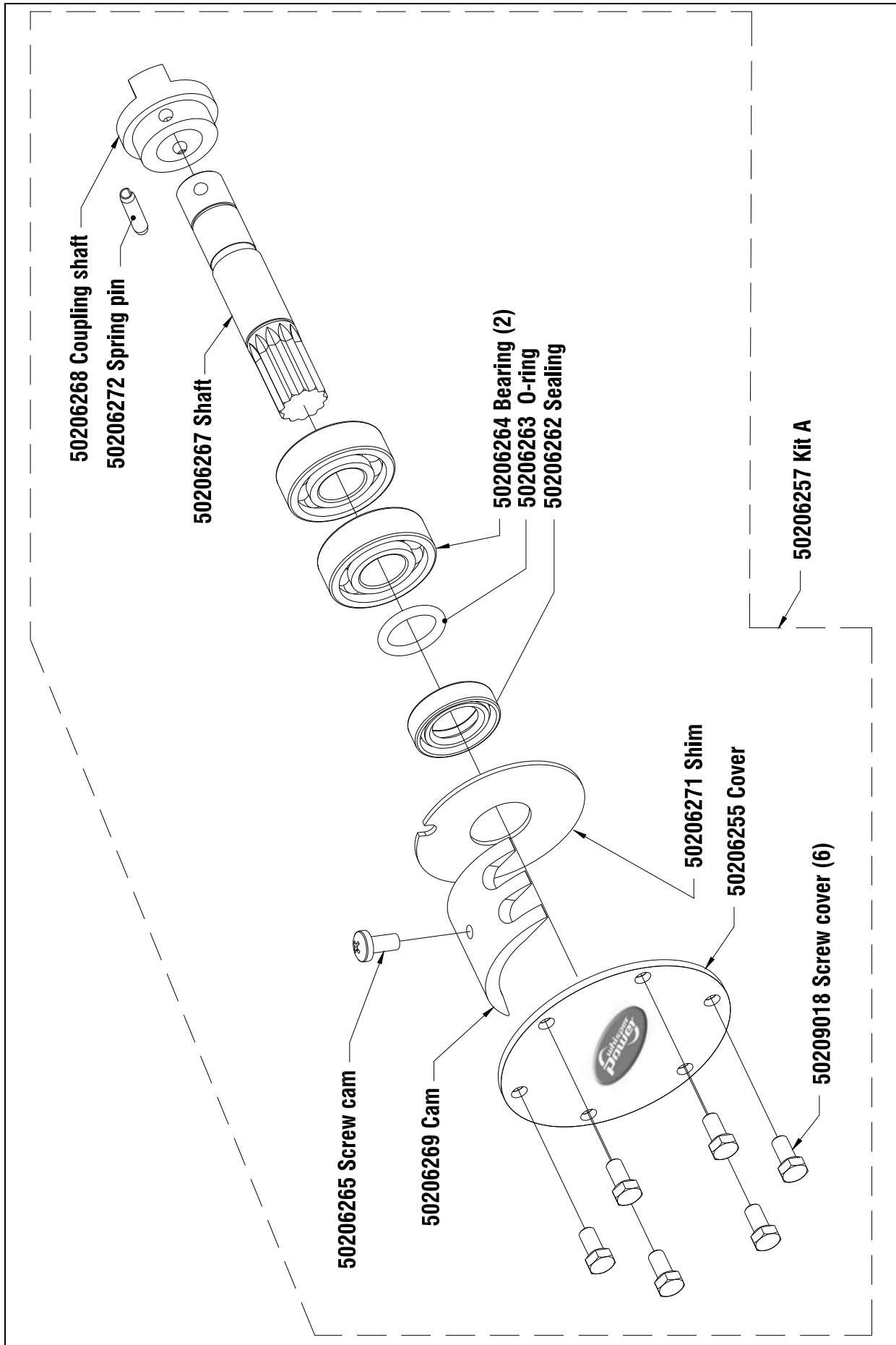



MAINTENANCE LOG

first service after 50 hours: hour counter: remarks:

next service (every 150 hours): hour counter: remarks:



Kelvinlaan 82, 9207 JB Drachten, Netherlands
Tel : + 31-512-571550 / Fax : + 31-512-571599
www.whisperpower.eu / info@whisperpower.nl