

INSTALLATION

# ➤ Instructions

## Thule Slide Out G2 12V MB Sprinter

301885, 301860

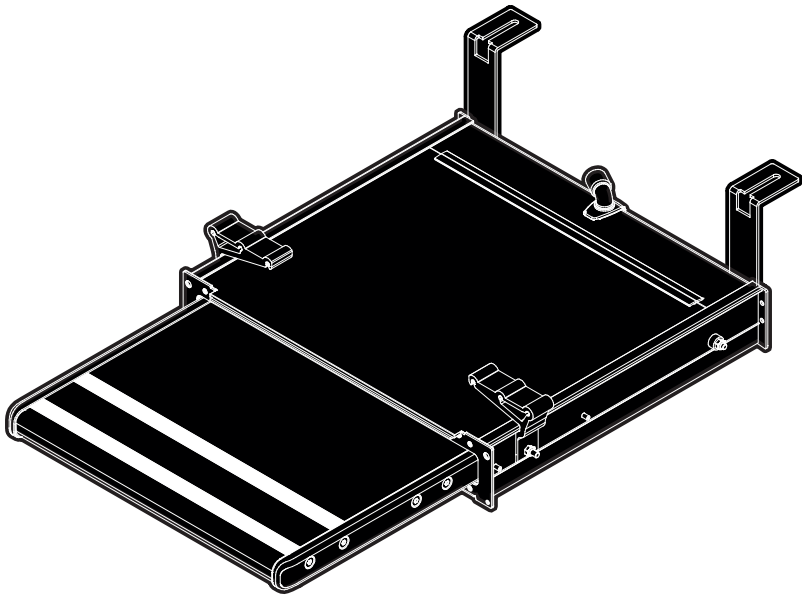



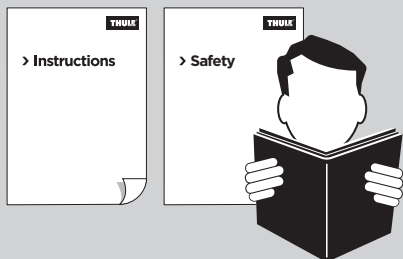

<b>DE</b>	Trittstufen - Bedienungsanleitung
<b>NL</b>	Opstaptrade - Gebruikershandleiding
<b>FR</b>	Marchepieds - Instructions d'utilisation
<b>IT</b>	Gradini - Istruzioni per l'uso
<b>ES</b>	Escalones - Manual de usuario
<b>SV</b>	Fotsteg - Användarmanual
<b>FI</b>	Astinlaudat - Käyttöohje
<b>DA</b>	Trapper - Brugermanual
<b>NO</b>	Trapper - Brukerhåndbok
<b>PL</b>	Stopnie - Instrukcja obsługi

<b>1</b>	<b>WARNINGS &amp; INFO</b>	<b>4</b>
	Warnungen & Info / waarschuwingen & info / avertissements et informations / avvertimenti e informazioni / advertencias e información / varningar & info / varoitukset ja tiedot / advarsler og info / advarsler og info / ostrzeżenia i informację	
<b>2</b>	<b>CONTENT</b>	<b>5</b>
	Inhalt / inhoud / contenu / contenuto / contenido / innehåll / sisältö / indhold / innhold / zawartość	
<b>3</b>	<b>TOOLS</b>	<b>6</b>
	Werkzeuge / gereedschappen / outils / strumenti / herramientas / verktyg / työkalut / værktøjer / verktøy / narzędzia	
<b>4</b>	<b>INSTALLATION</b>	<b>7</b>
	Installation / installatie / installation / installazione / instalación / installation / asennus / installation / instalasjon / instalacja	
<b>5</b>	<b>ELECTRICAL INSTALLATION</b>	<b>12</b>
	Elektroinstallation / Elektrische installatie / Installation électrique / Installazione elettrica / Instalacion electrica / Elektrisk installation / Sähköinen asennus / Elektrisk installation / Elektrisk installasjon / Instalacja elektryczna	
<b>6</b>	<b>ACCESSORIES</b>	<b>17</b>
	Zubehör / accessoires / accessoires / accessori / accesorios / tillbehör / tarvikkeet / tilbehør / tilbehør / akcesoria	

# 1 WARNINGS & INFO

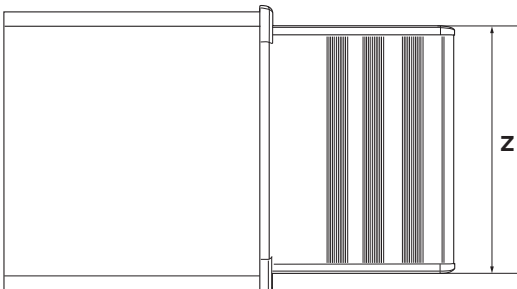
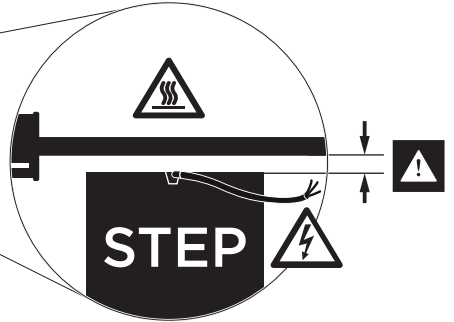
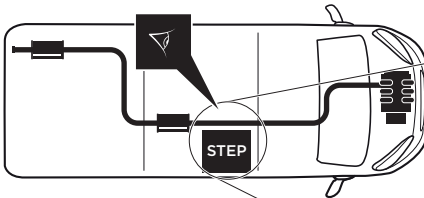
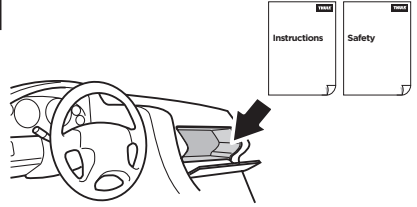
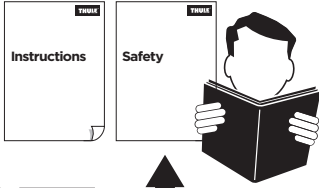

(TYPE 400) Z = 407  
Z (TYPE 550) Z = 552  
(TYPE 700) Z = 707



### 3 TOOLS

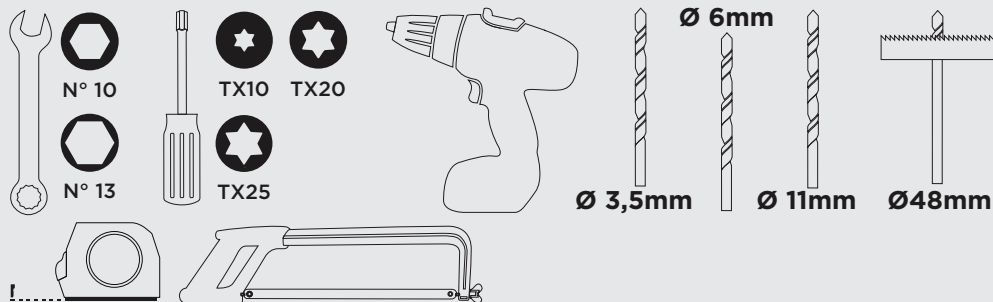

## 4 INSTALLATION

1



TX25

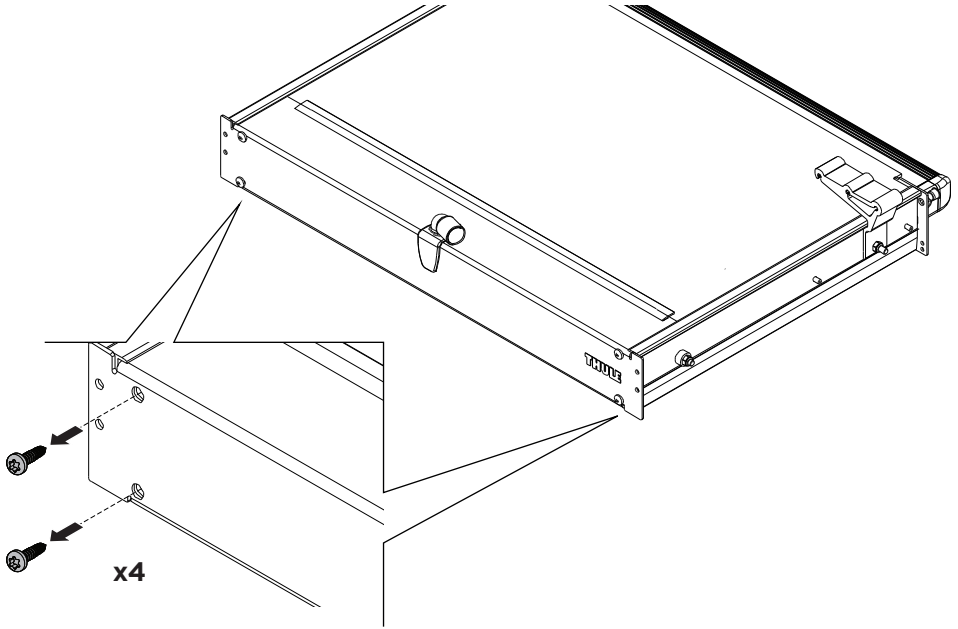

2

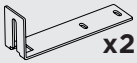

x2



TX25

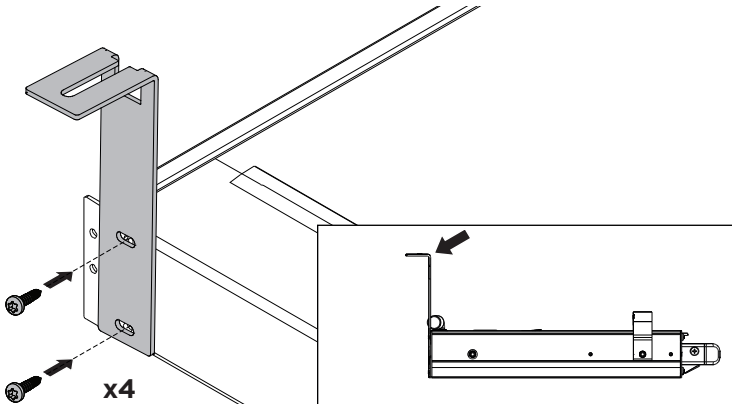

3



Ø 3,5mm



Ø 11mm

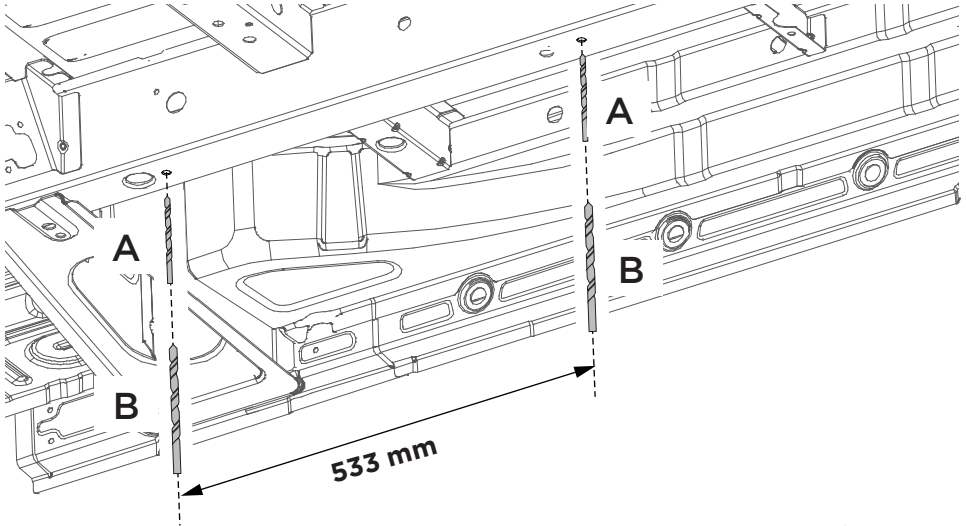

A = Ø 3,5 mm

B = Ø 11 mm

4



x2

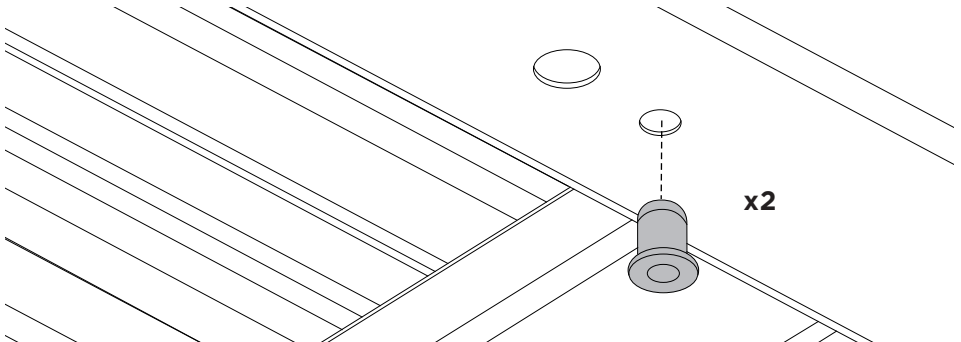



5

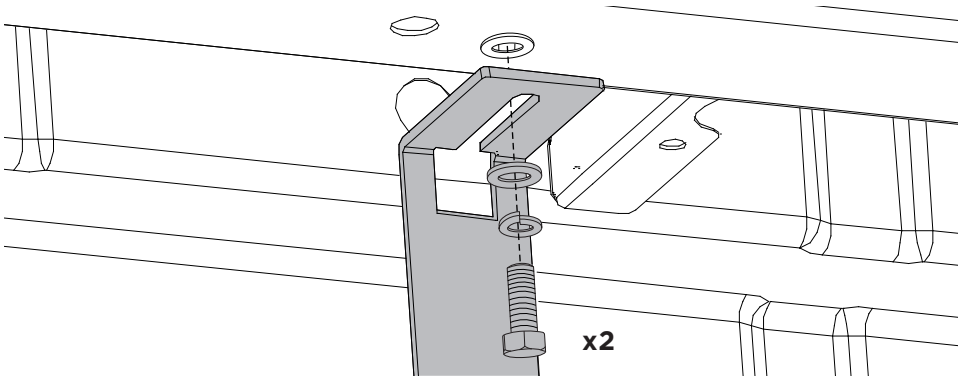

6

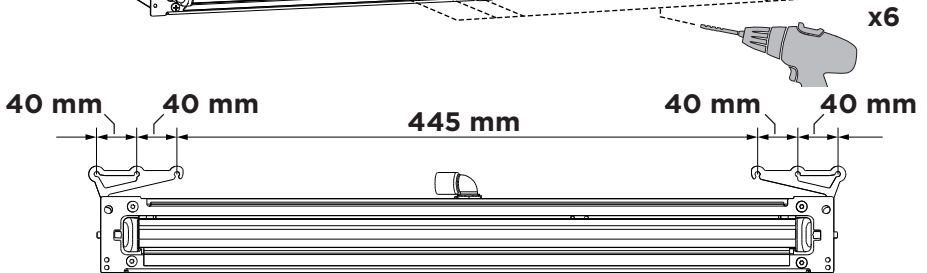
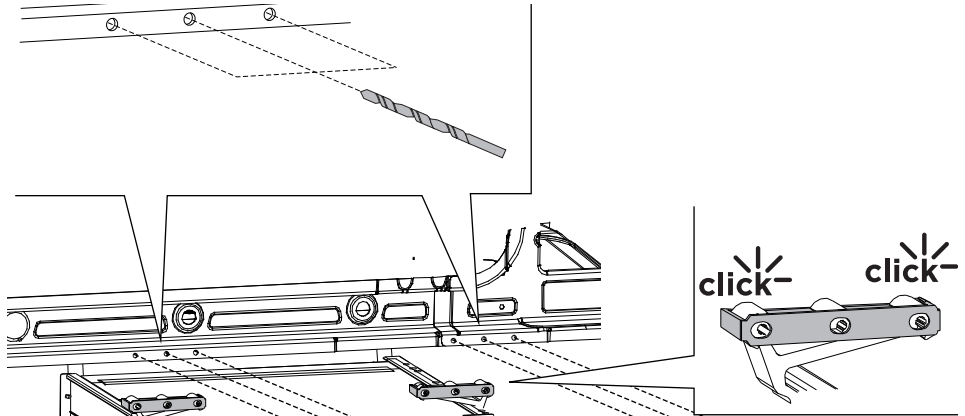
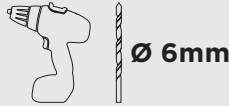
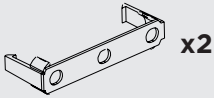

7

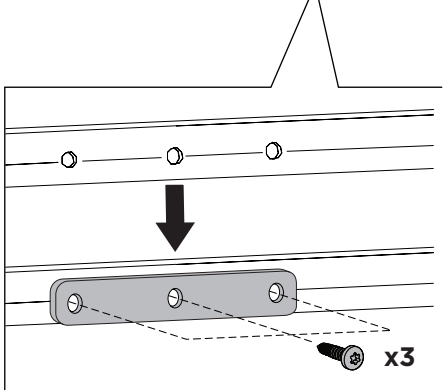
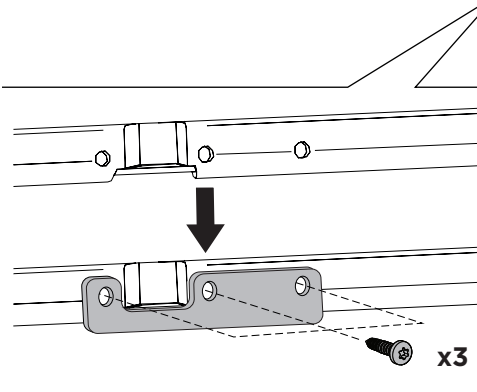
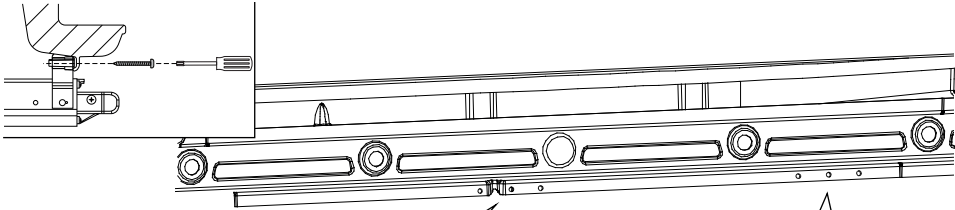

8

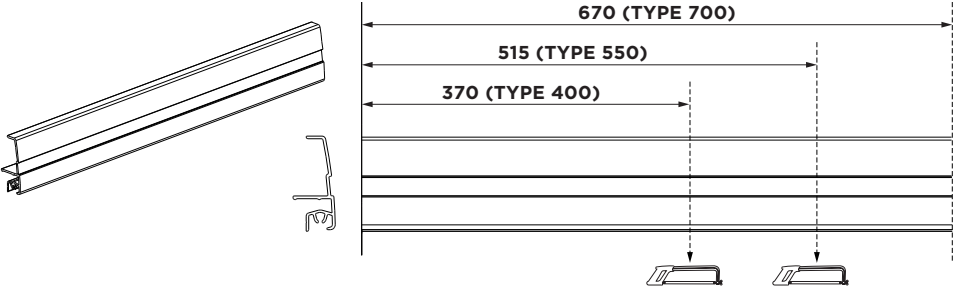
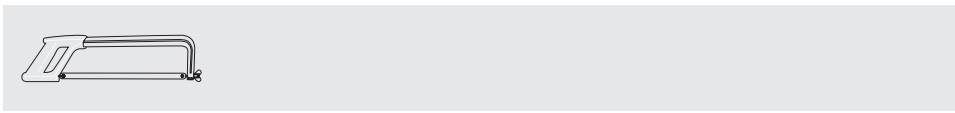

9

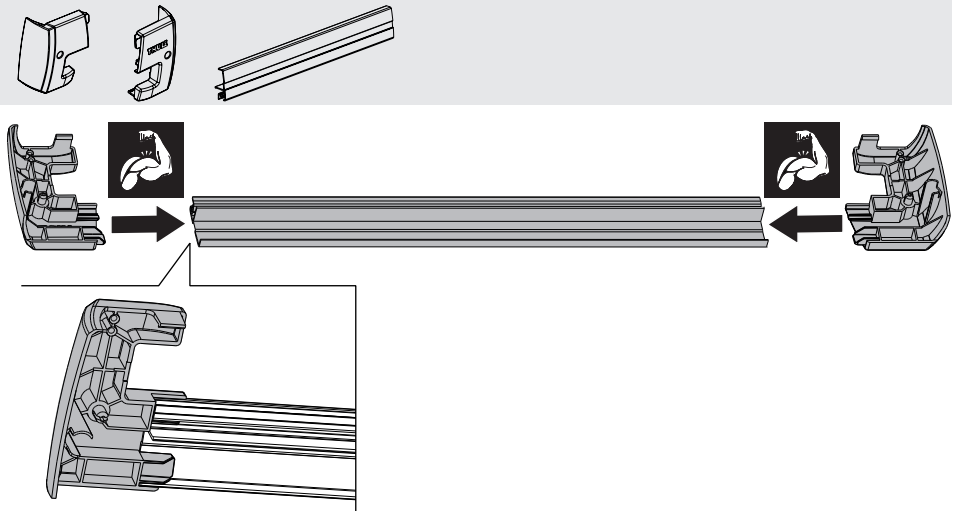

10

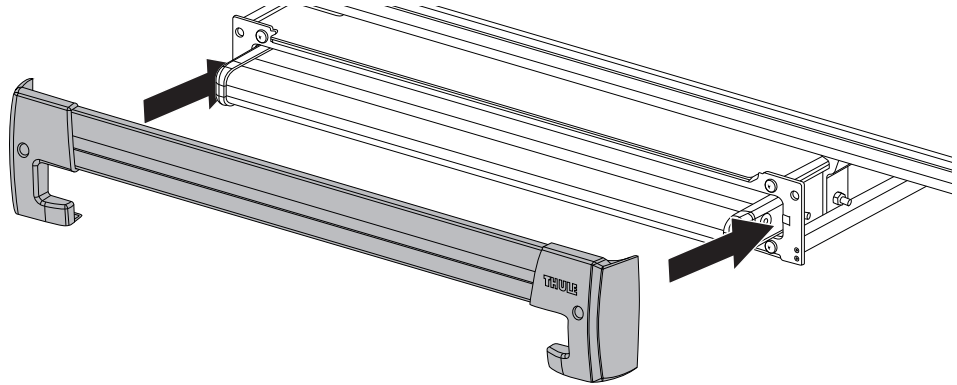

11

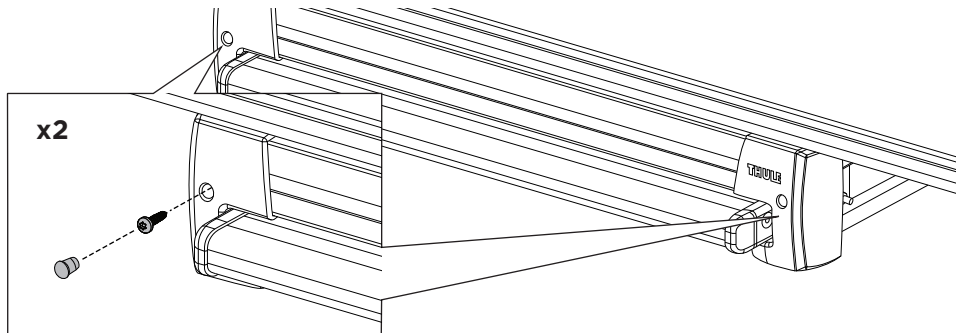

# 5 ELECTRICAL INSTALLATION

i



**RED/ROT/ROOD/  
ROUGE/ROSSO/ROJA/  
RÖD/PUNAINEN/RØD/  
RÖD/CZERWONY**

**BLACK/SCHWARZ/  
ZWART/NOIR/NERO/  
NEGRO/SVART/  
MUSTA/SORT/SVART/  
CZARNY**

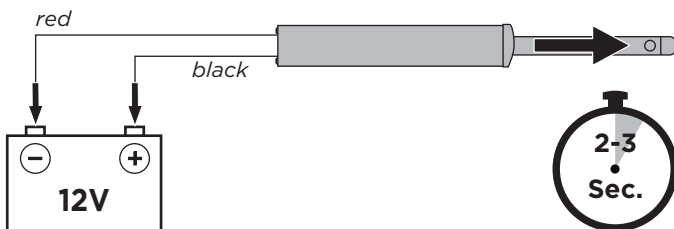
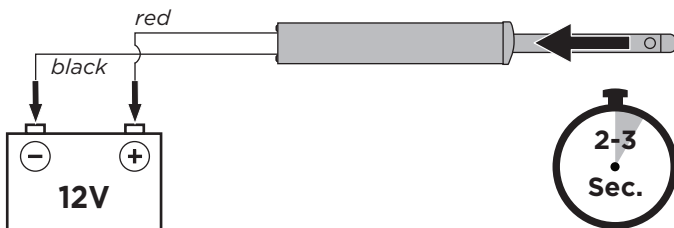

1

**OPTIONAL**

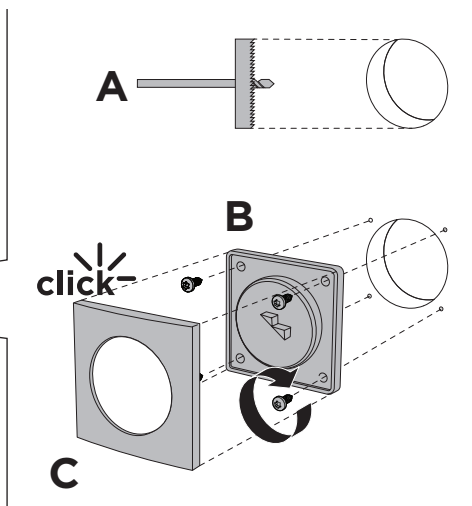
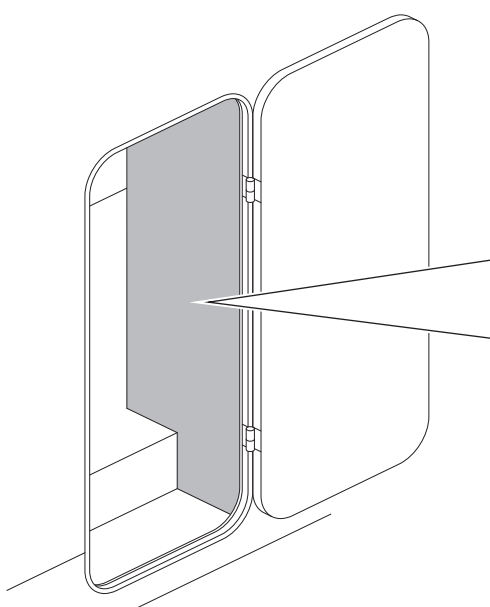
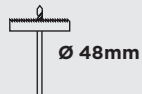

# THULE STEP with WARNING LAMP (or BUZZER)

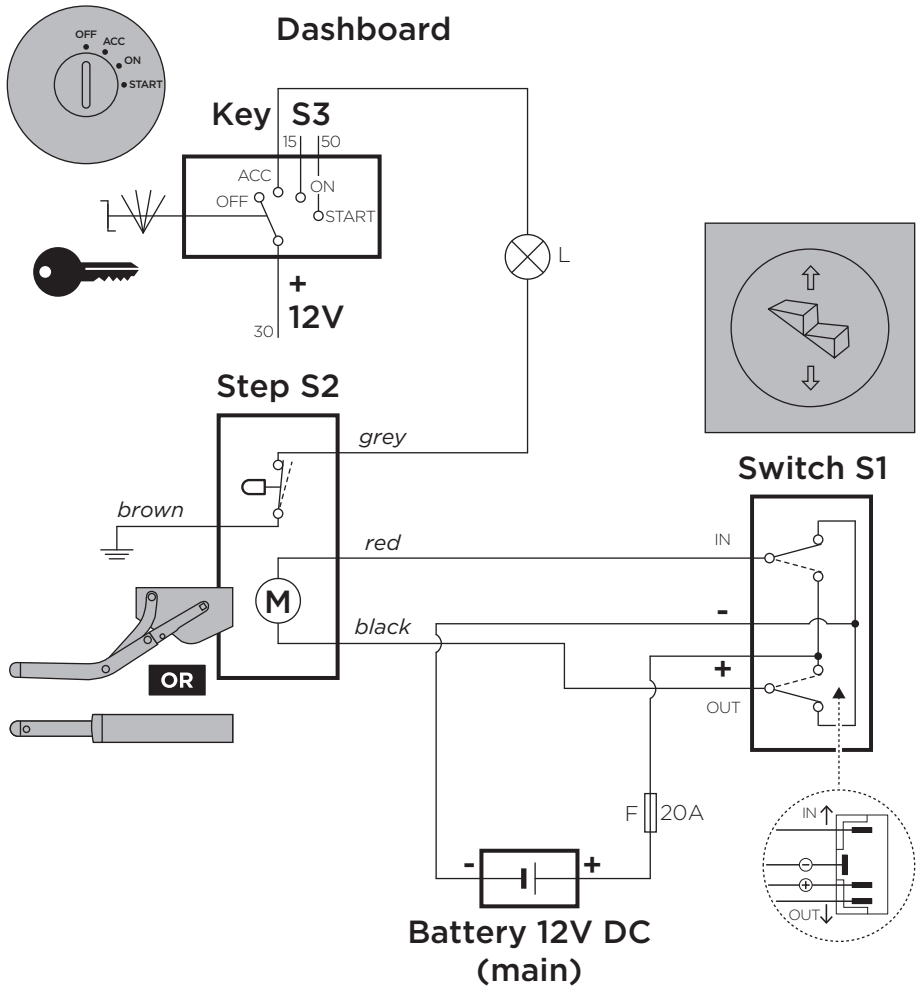

**BLACK/SCHWARZ/  
ZWART/NOIR/NERO/  
NEGRO/SVART/  
MUSTA/SORT/SVART/  
CZARNY**

**GREY/GRAU/GRIJS/  
GRISE/GRIGIO/GRIS/  
GRÅ/HARMAA/GRÅ/  
GRÅ/SZARY**

**RED/ROT/ROOD/  
ROUGE/ROSSO/ROJA/  
RÖD/PUNAINEN/RØD/  
RØD/CZERWONY**

**BROWN/BRAUN/  
BRUIN/MARRON/  
MARRONE/MARÓN/  
BRUN/RUSKEA/BRUN/  
BRUN/BRAZOWY**

# THULE STEP with OPTIONAL RELAY (308200) for AUTOMATIC RETRACTION

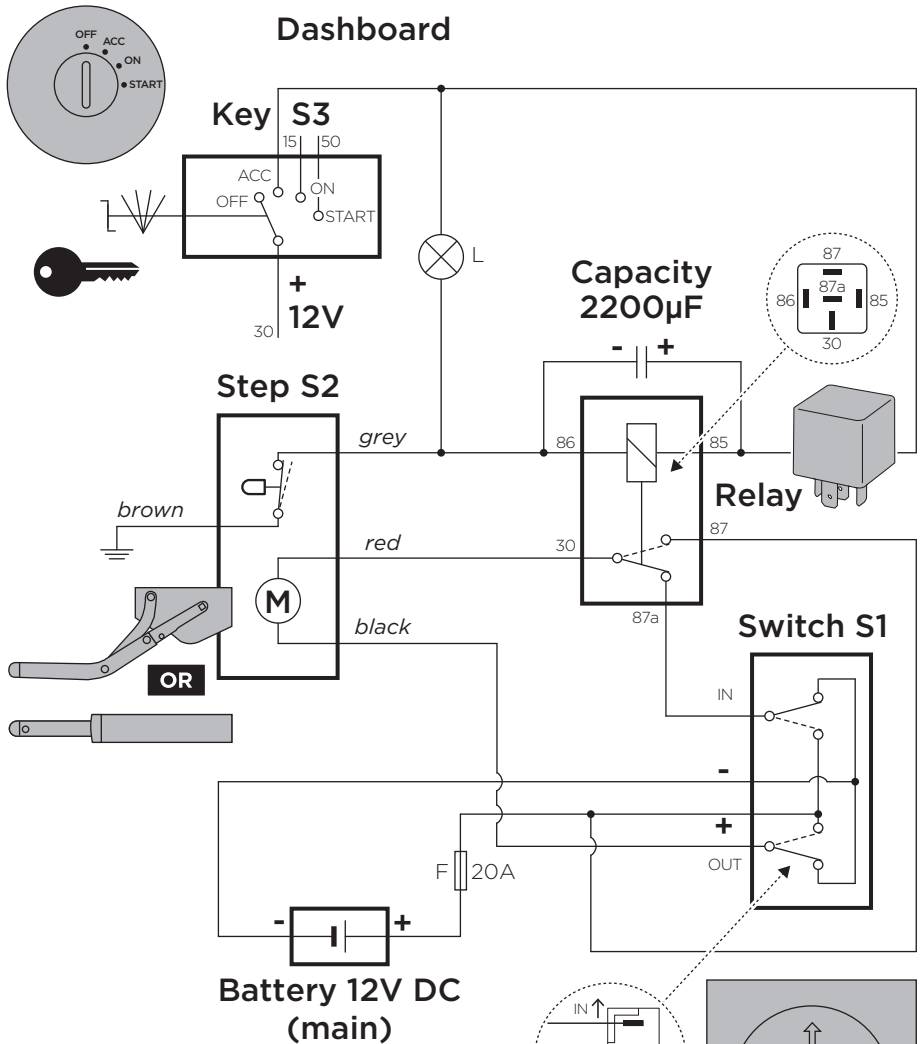

**BLACK/SCHWARZ/  
ZWART/NOIR/NERO/  
NEGRO/SVART/  
MUSTA/SORT/SVART/  
CZARNY**

**GREY/GRAU/GRIJS/  
GRISE/GRIGIO/GRIS/  
GRÅ/HARMAA/GRÅ/  
GRĄ/SZARY**

**RED/ROT/ROOD/  
ROUGE/ROSSO/ROJA/  
RÖD/PUNAINEN/RÖD/  
RÖD/CZERWONY**

**BROWN/BRAUN/  
BRUIN/MARRON/  
MARRONE/MARÓN/  
BRUN/RUSKEA/BRUN/  
BRUN/BRAZOWY**

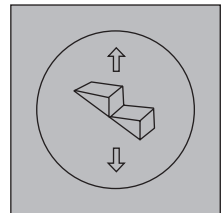
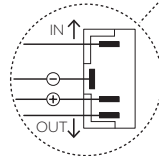

2

i

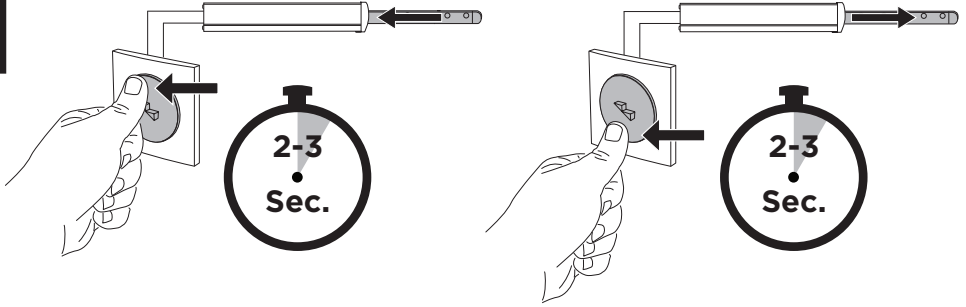

3

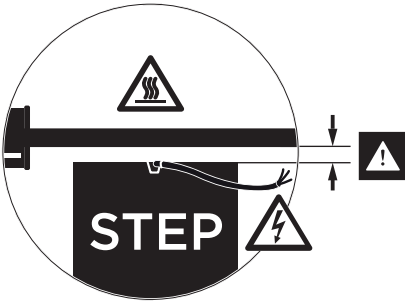
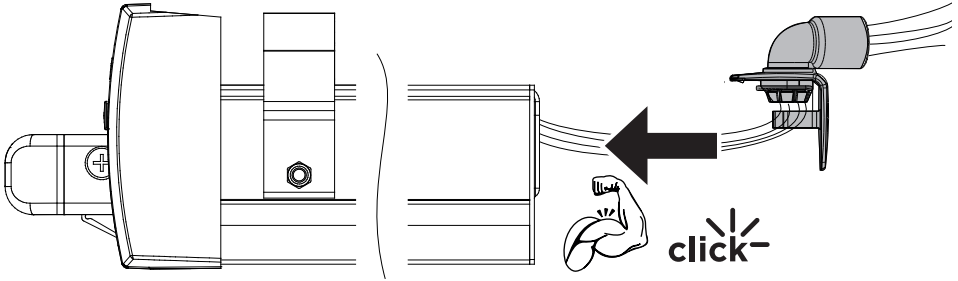

OR

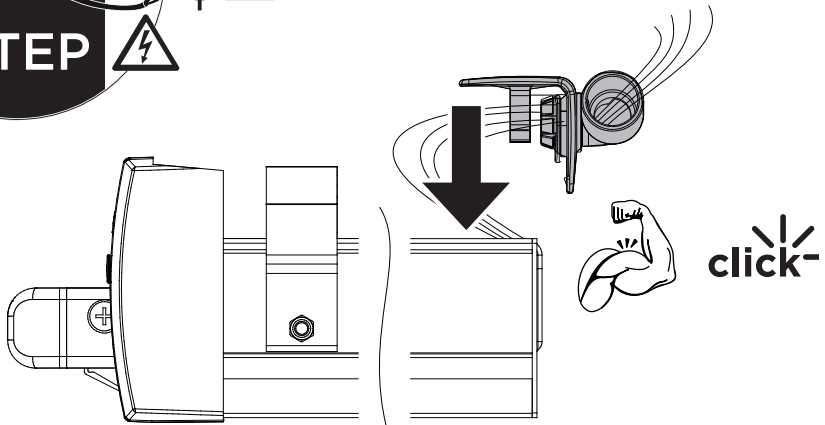

**i**

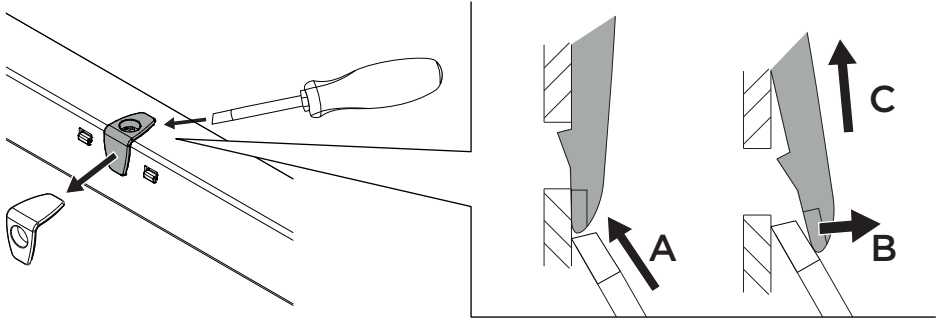

**4**

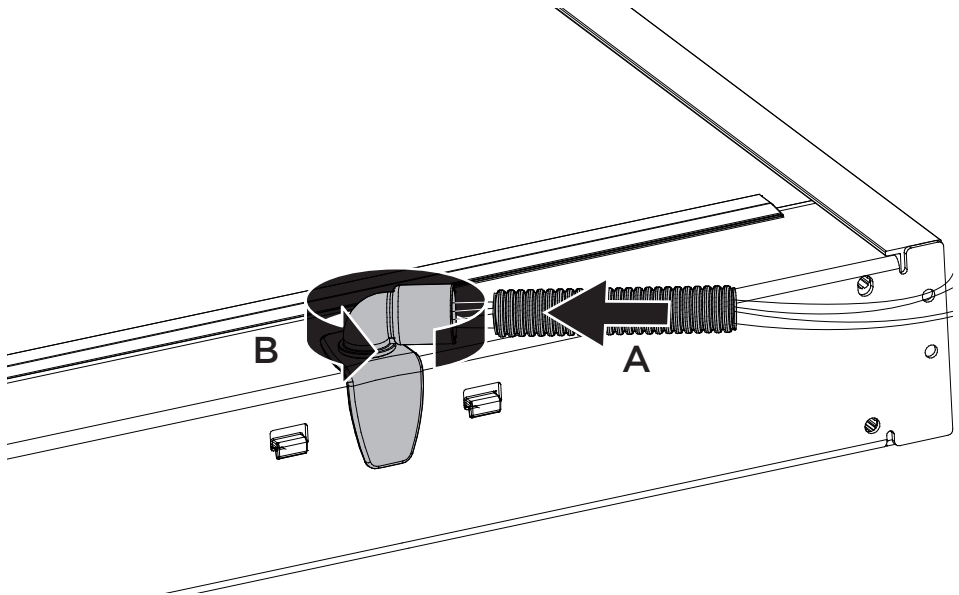



## 6 ACCESSORIES

**Electronic control unit (308812)**

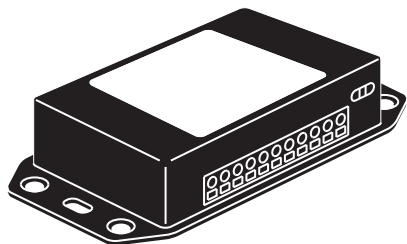

**Relay for Automatic retraction x10 (308200)**

