

Geschwindigkeit 3-stufig SPEED IN 3 STEPS				
Kammer-Nr. TERMINAL CAVITY NO.	Anschlussbezeichnung TERMINAL DESIGNATION	Farbe COLOUR	COLOUR	Querschnitt mm <sup>2</sup> CROSS SECTION
1	Ausg. 2 *	gelb	YELLOW	0,75
2	Ausg. 1 *	grau	GREY	0,75
3	---	---	---	---
4	15 (53a)	blau	BLUE	0,75
5	---	---	---	---
6	rückwärts (R)	weiß-grün	WHITE-GREEN	0,75
7	neutral (N)	violett	VIOLET	0,75
8	vorwärts (F)	blau-gelb	BLUE-YELLOW	0,75
9	15	rot	RED	0,75
-	KD *	schwarz-gelb	BLACK-YELLOW	0,75

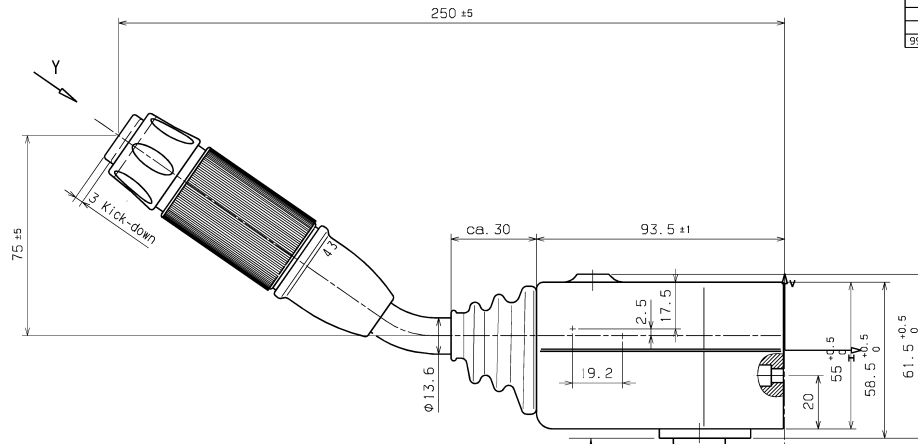

Geschwindigkeit 4-stufig SPEED IN 4 STEPS				
Kammer-Nr. TERMINAL CAVITY NO.	Anschlussbezeichnung TERMINAL DESIGNATION	Farbe COLOUR	COLOUR	Querschnitt mm <sup>2</sup> CROSS SECTION
1	Ausg. 3 *	grün	GREEN	0,75
2	Ausg. 2 *	gelb	YELLOW	0,75
3	---	braun	BROWN	0,75
4	15 (53a)	blau	BLUE	0,75
5	Ausg. 1	grau	GREY	0,75
6	rückwärts (R)	weiß-grün	WHITE-GREEN	0,75
7	neutral (N)	violett	VIOLET	0,75
8	vorwärts (F)	blau-gelb	BLUE-YELLOW	0,75
9	15	rot	RED	0,75
-	KD *	schwarz-gelb	BLACK-YELLOW	0,75

•hochflex Litzen  
•HIGH FLEX CABLES



Zulässige Kontaktbelastung ca. 1A induktiv bei 24V  
PERMISSIBLE CONTACT LOAD APPROX. 1A INDUCTIVE WITH 24V

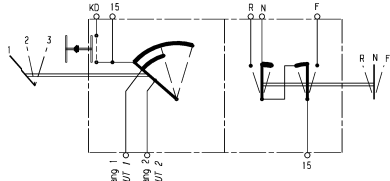

Drehwinkel für Gangwahl  
ANGLES OF ROTATION FOR GEAR SELECTION

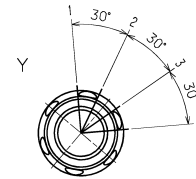

Gehäuse RDST-SWF-Nr. 909.505  
AMP-Nr. 480673-0  
Passender Stecker RD SWF-Nr. 921.133  
AMP-Nr. 926.988-1

Hebel: Stahl mit schwarzem Schrumpfschlauch überzogen  
LEVER: STEEL COVERED WITH BLACK SHRINK-FIT SLEEVE

Griff: schwarz  
GRIP: BLACK

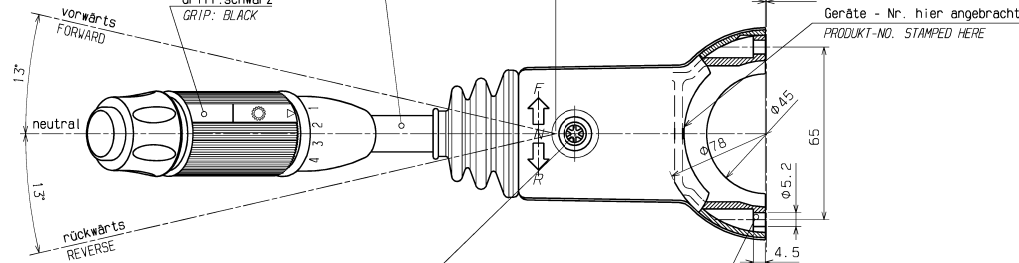

Schraube M5 mit Innentorx, selbstformend  
Anzugsmoment 1,5-2,0 Nm  
SCREW M5 WITH INTERNAL TORX THREAD FORMING  
TIGHTENING TORQUE 1,5-2,0 Nm

Passende Schraube M5x16, Kopf Ø8,5  
SWF-Nr. 916.804  
MATCHING SCREW M5 x 16, HEAD Ø8,5  
SWF-NO. 916.804

Zulässige Kontaktbelastung ca. 1A induktiv bei 24V  
PERMISSIBLE CONTACT LOAD APPROX. 1A INDUCTIVE WITH 24V

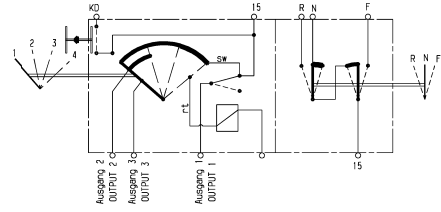

Nicht tol. Masse	Gen. tolerances +	0,5	0,5	0,5	0,5	0,5	0,5	0,5	0,5				
Zul. Abw.	Gen. tolerances +	0,5	0,5	0,5	0,5	0,5	0,5	0,5	0,5				
Nicht tol. Winkel zul. Abw.	Gen. angle tolerance +	2°	2°	2°	2°	2°	2°	2°	2°				
Alle Maße in mm		All dimensions in mm		Massestab		Scale		Kurz-Bezeichnung		Title		Art-Nr. Cat.	
1:1		1:1		LS		SWITCH LS		SWITCH SC		0700			
202.861		3-stufig		3 STEPS		202.861		4-stufig		4 STEPS			
202.861		Kunden-Nr.		Bemerkung		202.861		Zeichnungs-Nr.		Drawing no.		Blatt Sheet	
202.861		Sach-Nr.		REMARK		202.861		A		202.861		1	
202.861		Kunden-Nr.		Bemerkung		202.861		A		202.861		1	
202.861		Sach-Nr.		REMARK		202.861		A		202.861		1	
202.861		Kunden-Nr.		Bemerkung		202.861		A		202.861		1	
202.861		Sach-Nr.		REMARK		202.861		A		202.861		1	
202.861		Kunden-Nr.		Bemerkung		202.861		A		202.861		1	
202.861		Sach-Nr.		REMARK		202.861		A		202.861		1	
202.861		Kunden-Nr.		Bemerkung		202.861		A		202.861		1	
202.861		Sach-Nr.		REMARK		202.861		A		202.861		1	
202.861		Kunden-Nr.		Bemerkung		202.861		A		202.861		1	
202.861		Sach-Nr.		REMARK		202.861		A		202.861		1	
202.861		Kunden-Nr.		Bemerkung		202.861		A		202.861		1	
202.861		Sach-Nr.		REMARK		202.861		A		202.861		1	
202.861		Kunden-Nr.		Bemerkung		202.861		A		202.861		1	
202.861		Sach-Nr.		REMARK		202.861		A		202.861		1	
202.861		Kunden-Nr.		Bemerkung		202.861		A		202.861		1	
202.861		Sach-Nr.		REMARK		202.861		A		202.861		1	
202.861		Kunden-Nr.		Bemerkung		202.861		A		202.861		1	
202.861		Sach-Nr.		REMARK		202.861		A		202.861		1	
202.861		Kunden-Nr.		Bemerkung		202.861		A		202.861		1	
202.861		Sach-Nr.		REMARK		202.861		A		202.861		1	
202.861		Kunden-Nr.		Bemerkung		202.861		A		202.861		1	
202.861		Sach-Nr.		REMARK		202.861		A		202.861		1	
202.861		Kunden-Nr.		Bemerkung		202.861		A		202.861		1	
202.861		Sach-Nr.		REMARK		202.861		A		202.861		1	
202.861		Kunden-Nr.		Bemerkung		202.861		A		202.861		1	
202.861		Sach-Nr.		REMARK		202.861		A		202.861		1	
202.861		Kunden-Nr.		Bemerkung		202.861		A		202.861		1	
202.861		Sach-Nr.		REMARK		202.861		A		202.861		1	
202.861		Kunden-Nr.		Bemerkung		202.861		A		202.861		1	
202.861		Sach-Nr.		REMARK		202.861		A		202.861		1	
202.861		Kunden-Nr.		Bemerkung		202.861		A		202.861		1	
202.861		Sach-Nr.		REMARK		202.861		A		202.861		1	
202.861		Kunden-Nr.		Bemerkung		202.861		A		202.861		1	
202.861		Sach-Nr.		REMARK		202.861		A		202.861		1	
202.861		Kunden-Nr.		Bemerkung		202.861		A		202.861		1	
202.861		Sach-Nr.		REMARK		202.861		A		202.861		1	
202.861		Kunden-Nr.		Bemerkung		202.861		A		202.861		1	
202.861		Sach-Nr.		REMARK		202.861		A		202.861		1	
202.861		Kunden-Nr.		Bemerkung		202.861		A		202.861		1	
202.861		Sach-Nr.		REMARK		202.861		A		202.861		1	
202.861		Kunden-Nr.		Bemerkung		202.861		A		202.861		1	
202.861		Sach-Nr.		REMARK		202.861		A		202.861		1	
202.861		Kunden-Nr.		Bemerkung		202.861		A		202.861		1	
202.861		Sach-Nr.		REMARK		202.861		A		202.861		1	
202.861		Kunden-Nr.		Bemerkung		202.861		A		202.861		1	
202.861		Sach-Nr.		REMARK		202.861		A		202.861		1	
202.861		Kunden-Nr.		Bemerkung		202.861		A		202.861		1	
202.861		Sach-Nr.		REMARK		202.861		A		202.861		1	
202.861		Kunden-Nr.		Bemerkung		202.861		A		202.861		1	
202.861		Sach-Nr.		REMARK		202.861		A		202.861		1	
202.861		Kunden-Nr.		Bemerkung		202.861		A		202.861		1	
202.861		Sach-Nr.		REMARK		202.861		A		202.861		1	
202.861		Kunden-Nr.		Bemerkung		202.861		A		202.861		1	
202.861		Sach-Nr.		REMARK		202.861		A		202.861		1	
202.861		Kunden-Nr.		Bemerkung		202.861		A		202.861		1	
202.861		Sach-Nr.		REMARK		202.861		A		202.861		1	
202.861		Kunden-Nr.		Bemerkung		202.861		A		202.861		1	
202.861		Sach-Nr.		REMARK		202.861		A		202.861		1	
202.861		Kunden-Nr.		Bemerkung		202.861		A		202.861		1	
202.861		Sach-Nr.		REMARK		202.861		A		202.861		1	
202.861		Kunden-Nr.		Bemerkung		202.861		A		202.861		1	
202.861		Sach-Nr.		REMARK		202.861		A		202.861		1	
202.861		Kunden-Nr.		Bemerkung		202.861		A		202.861		1	
202.861		Sach-Nr.		REMARK		202.861		A		202.861		1	
202.861		Kunden-Nr.		Bemerkung		202.861		A		202.861		1	
202.861		Sach-Nr.		REMARK		202.861		A		202.861		1	
202.861		Kunden-Nr.		Bemerkung		202.861		A		202.861		1	
202.861		Sach-Nr.		REMARK		202.861		A		202.861		1	
202.861		Kunden-Nr.		Bemerkung		202.861		A		202.861		1	
202.861		Sach-Nr.		REMARK		202.861		A		202.861		1	
202.861		Kunden-Nr.		Bemerkung		202.861		A		202.861		1	
202.861		Sach-Nr.		REMARK		202.861		A		202.861		1	
202.861		Kunden-Nr.		Bemerkung		202.861		A		202.861		1	
202.861		Sach-Nr.		REMARK		202.861		A		202.861		1	
202.861		Kunden-Nr.		Bemerkung		202.861		A		202.861		1	
202.861		Sach-Nr.		REMARK		202.861		A		202.861		1	
202.861		Kunden-Nr.		Bemerkung		202.861		A		202.861		1	
202.861		Sach-Nr.		REMARK		202.861		A		202.861		1	
202.861		Kunden-Nr.		Bemerkung		202.861		A		202.861		1	
202.861		Sach-Nr.		REMARK		202.861		A		202.861		1	
202.861		Kunden-Nr.		Bemerkung		202.861		A		202.861		1	
202.861		Sach-Nr.		REMARK		202.861		A		202.861		1	
202.861		Kunden-Nr.		Bemerkung		202.861		A		202.861		1	
202.861		Sach-Nr.		REMARK		202.861		A		202.861		1	
202.861		Kunden-Nr.		Bemerkung		202.861		A		202.861		1	
202.861		Sach-Nr.		REMARK		202.861		A		202.861		1	
202.861		Kunden-Nr.		Bemerkung		202.861		A		202.861		1	
202.861		Sach-Nr.		REMARK		202.861		A		202.861		1	
202.861		Kunden-Nr.		Bemerkung		202.861		A		202.861		1	
202.861		Sach-Nr.		REMARK		202.861		A		202.861		1	
202.861		Kunden-Nr.		Bemerkung		202.861							