

Marine Catalog

Heating, Cooling and Roof Solutions

2023



Table of Contents

Welcome to Webasto Marine	4
What's new?	6
We Are Here to Help Develop Your Business	8
<hr/>	
Heating Products	10
Heating Accessories	38
<hr/>	
Cooling Products	86
Cooling Accessories	134
<hr/>	
Integrated Solutions	162
<hr/>	
Roof & Shading Solutions	170
<hr/>	
Further Information	
Nomenclature	188
Webasto subsidiaries and representatives	190
Abbreviations	193
<hr/>	

Welcome to Webasto Marine



Dear Customers, Dear Partners,

Our Webasto marine team would like to thank you again for your periodical feedback on our products and for sharing your future needs. This unique customer-supplier cooperation brings an immense value to us and is one of the main input for our future product roadmaps. Your ideas to improve comfort on board, your needs to simplify your systems, your suggestions to facilitate installations and ease diagnosis, even from a remote location are indeed systematically studied with high attention. Our engineering teams are committed to develop innovative technological solutions to match or to surpass your expectations.

Our long-term innovation-based growth strategy is based on this partnership approach. Our commitment to innovation has been making up our great success over the last years and hopefully for many more years to come. We do hope that the numerous new products which are once again being launched in this catalog will match your initial expectations and enhance our complete on board climate solutions with many additional benefits valued by your own customers.

In this new marine catalog 2023, we keep on with our innovation pace not only by introducing several new products to our climate control range but also by launching a new family member to our shading solutions, the Telescopic Shade 2500.

You will discover in the following pages our new BlueCool V-PRO chiller system which consists of four different modular chiller units which may be flexibly combined to provide up to 1 Mio. BTU/h. The V-PRO system comes with a number of intelligent functions and optional accessories to match your demands.

The BlueCool Connect has already proven to be an excellent choice for remote operation and monitoring your boat's A/C system. Now, the product has received an update featuring an NMEA2000 interface and also offering a plug & play solution for Raymarine, Simrad, Lowrance and B & G displays with HTML5 functionality.

Based on the success of our Folding Shade 2500 system which was appreciated by many customers worldwide we have extended our range and introduced the Folding Shade 3500. This shade has a maximum dimension of 3.5 meter in width and 5 meter length! In this catalogue we are now revealing our latest innovation: the Telescopic Shade 2500. It is the perfect solution to provide shade on the rear deck or the flybridge and can be operated at the touch of a button.

The purpose of this catalog is not only to give you a complete, practical insight into our large marine product portfolio but also to enable you to build complete climate solutions adapted to the demands of your customers for heating, cooling, light and fresh air on board. Should you require a custom-made solution for a special project, our engineering teams also have the capability to develop customized products to support you. Just get in touch with us!

International service and consistent quality of support are an essential part of our customer excellence programs. The marine catalog is only one element of the complete set of tools and services with which we systematically provide to every Webasto marine partner. Please don't hesitate to register for our technical training sessions, to request access to our dealer portal, to download our diagnosis and calculation tools, our product information and marketing materials. We are here to support your business so that your customers can enjoy the same high quality service with our products worldwide. Our financial strength, our unique product portfolio, our large international dealer network and our understanding of your key strategic challenges for the future have positioned us as your supplier of choice when it comes to complete comfort solutions.

We would like to thank you again for your continuous feedback and your trust in our products. Your success is our success!

Your Webasto Marine Team

The new marine catalog provides you with detailed information on our core products as well as on our added-value accessories. You can then build safe applications and deliver fast, professional assistance to your own customers.

The V-PRO Series is the new variable speed chiller system to build large, chilled water systems.

This chiller system consists of four different modular sizes which may be flexibly combined to provide up to 1 Mio. BTU/h. The V-PRO system comes with a number of intelligent functions and optional accessories to match your demands.

New BlueCool V-PRO Series

Four units – two sizes – ONE system

- Four modular units of 60, 90, 130 or 180 kBTU/h, providing up to 1 Mio. BTU/h of system cooling capacity
- Variable speed technology for best efficiency
- Highest cooling performance with high efficiency inverter, variable speed scroll compressor and energy saving ECO modes

High system availability

- Fully autonomous units for high system availability and continuous operation

Unified hydraulic connection

- Layout of hydraulic connection is identical for all four models

Water flow monitoring

- Water flow monitoring integrated for safe and reliable operation

Powerful user interface

- Full color touch-screen display
- Fully redundant, each shows overall system data
- Multiple languages

Outstanding corrosion resistance

- Titanium sea water heat exchanger for outstanding corrosion resistance

Combination of autonomous units

- Simple network cable immediately creates overall system control

BlueCool Connect and Connect App

- Remote access to all BlueCool Series
- Use any device like Smartphone, Tablet or Computer
- Central monitoring via your Multi-Functional-Display e.g. Garmin, Raymarine, Simrad, Lowrance and B&G with HTML5 functionality
- Remote diagnosis and monitoring system
- NMEA 2000 interface

BlueCool MyTouch

- Touch display control unit as standard for all BlueCool A/C series
- Intuitive operation thanks to simple symbols and a clearly organized control menu in ten languages
- Three digital designs allow to customize the user menu
- Upload of own logo or photograph as standby image
- New functions such as a timer, error messages with descriptions, display of operating values and a configuration of the standby display
- Compatible with Vimar Eikon, Eikon Evo and other cover plate

New Shading Solutions

New since 2022: Telescopic Shade 2500

- 12 V powered system, fully retractable and customizable widths up to 8 feet (2.500 mm)
- Marine-grade stainless steel tubing
- High-quality, eco-friendly shade fabric
- Easy installation
- Easily retrofitted or integrated by boat builders
- Options for any size or style boat (with an overhead structure)



BlueCool V-PRO Series



BlueCool Connect App



BlueCool MyTouch



Telescopic Shade 2500

We Are Here to Help Develop Your Business



Marine website webasto-marine.com

- Quick and appealing product guide
- International dealer locator
- Multi-lingual access
- Marine configurator



Marine training program and technical guidelines

- Powerful product training – also web-training
- Regular updates on new features
- Various modules adapted to audience
- Important guidelines for safe application engineering
- CAD model downloads

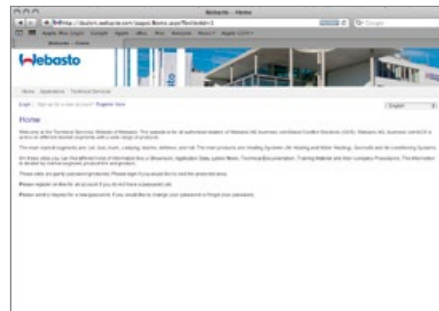

Dealer portal <http://dealers.webasto.com>

- Easy access to complete Webasto documentation
- Powerful search and download tools
- Login-protected access to technical data and applications

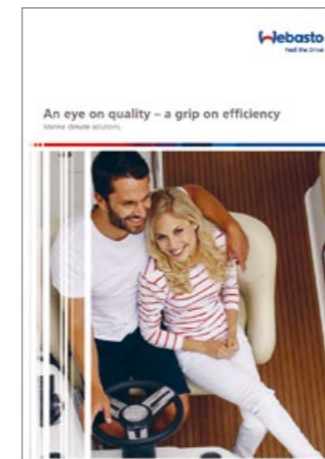

Marketing documentation and materials

- Marine marketing materials: product brochures, flyers, advertising templates, banners
- Marine animations
- Product data sheets
- Dealer packages

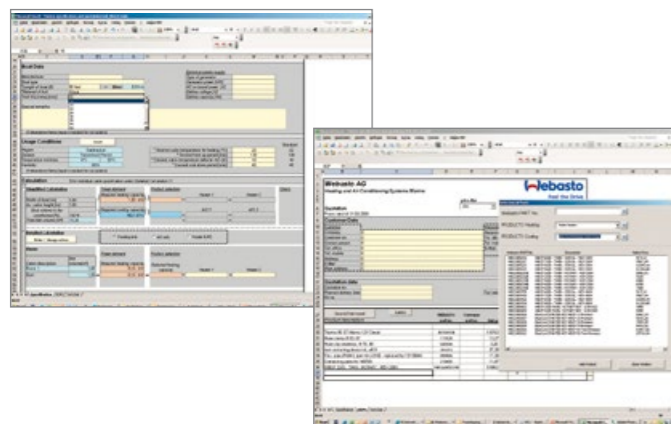

Webasto quote generator

- All the Webasto expertise at your finger tips
- Accurate quotations documented professionally
- Quick response to your customer requests
- Fresh air calculation included
- Accurate calculation of the cooling or heating demand
- The Webasto quote generator also exists for professional roof quotations

This catalog has been designed to help you in defining a complete comfort solution for boats and yachts.

Page header indicates which part and type of information you reached within each product section: Product overview, scopes of delivery, accessories, etc.

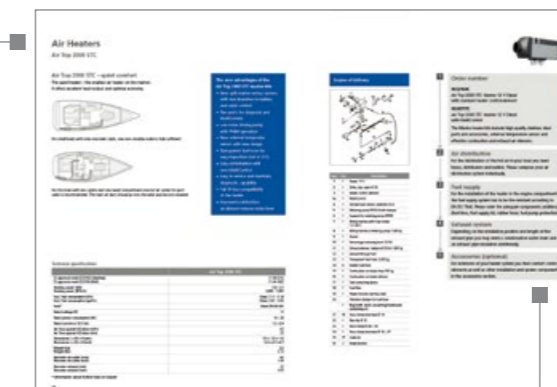

Colored labels give you direct access to the product range

Page indication for fast access to accessories, etc.



Heating Products

Which Heater for Your Boat?	12
------------------------------------	----

Air Heaters	14
Product Overview	15
Application Concept	16
Selection Tool	17
Air Top 2000 STC	18
Air Top Evo 40	20
Air Top Evo 55	22

Water Heaters	24
Product Overview	25
Application Concept	28
Selection Tool	29
Thermo Top Evo/Thermo Pro 50 Eco	30
Thermo Pro 90/Thermo Pro 90 Chiller	32
Thermo Top Pro 120/120 Chiller/150	34

Isotemp Hot Water Boilers	36
----------------------------------	----

Which Heater for Your Boat?



Along with specific marine installation kits we deliver innovative high-quality air and water heaters, which contribute to the enhancement of comfort on board. These two technologies offer economical, powerful and reliable solutions with heating outputs ranging from 2 kW up to 120 kW. Thus, there is a Webasto heating solution for various needs.

Air Heaters



- Short heating-up times thanks to effective output
- Available as a complete installation kit for quick and simple retrofitting
- Dehumidification of the cabins
- Silent operation
- Ideal for sailing and motor boats up to 45 feet
- Constant coziness thanks to an electronic thermostat
- Low operating costs
- Practical ventilation function
- Meet current requirements and standards relating to boats
- Simple to install
- Compact, space-saving design

or

Water Heaters



- Heating comfort just like at home
- Even distribution of warmth by means of radiators
- Hot water for the shower and galley
- Silent operation
- Space-saving installation in the engine room
- Excellent possibilities for combining with Webasto BlueCool air-conditioning systems
- Separate temperature control in every cabin
- Low fuel consumption
- Compact design
- Preheating of the engine possible to avoid cold starts
- Meet current requirements and standards relating to boats
- Robust aluminum casing, resistant to high temperature or salt

Air Heaters

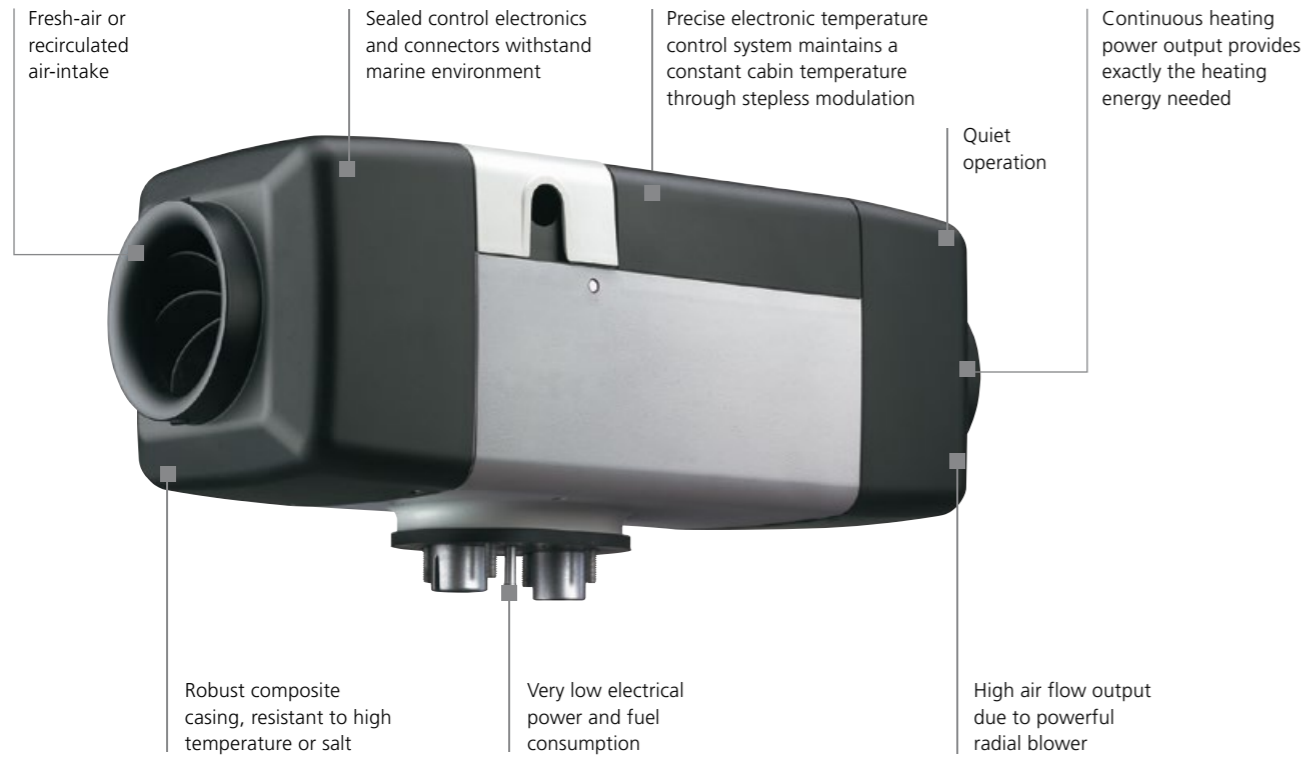

3 Heaters in 1 with the MultiControl!

- Available as an upgrade on all Webasto Air Top Evo heaters
- Multi mode operation to match your individual heating power demands:

ECO mode for reduced electrical power consumption

Boost mode for maximum heating power output

Ventilation mode to provide fresh and cool air to your cabins on a hot day

ThermoConnect TCon2

- With our ThermoConnect app, you can control your water or air heater smarter and more flexible than ever before.
- Available for iOS and Android devices:



Air Heaters

Product Overview



Air Top 2000 STC [See page 18](#)



Air Top Evo 40 [See page 20](#)

Air Top Evo 55 [See page 22](#)

Technical specifications

	Air Top 2000 STC	Air Top Evo 40*	Air Top Evo 55**
EC approval mark ECE R122 (Heating)	E1 00 0216	E1 00 0385	E1 00 0386
EC approval mark ECE R10 (EMC)	E1 06 1085	E1 05 5529	E1 05 5529
Heat output, control range/boost (kW)	0.9 – 2.0	1.5 – 3.5/4.0*	1.5 – 5.0/5.5**
Heat output, control range/boost (BTU/h)	3,000 – 7,000	5,100 – 12,000/13,600*	5,100 – 17,000/18,800**
Fuel, Fuel consumption (l/h)	Diesel, 0.12 – 0.24	Diesel, 0.18 – 0.43/0.49*	Diesel, 0.18 – 0.61/0.67**
Fuel, Fuel consumption (gal/h)	Diesel, 0.03 – 0.06	Diesel, 0.04 – 0.11/0.12*	Diesel, 0.04 – 0.15/0.17**
Rated voltage (V)	12	12, 24	12, 24
Rated power consumption (W)	14 – 29	15 – 40/55*	15 – 95/130**
Rated current (for 12 V) (A)	1.2 – 2.4	1.3 – 3.3/4.6*	1.3 – 7.9/10.8**
Rated current (for 24 V) (A)	–	0.6 – 1.7/2.3*	0.6 – 4.0/5.4**
Air Flow against 0.5 mbar (m³/h)	93	132/140*	200/220**
Air Flow against 0.5 mbar (cfm)	55	77.7/82.4*	117.7/129.4**
Dimensions L x W x H (mm)	310 x 120 x 118	423 x 148 x 162	423 x 148 x 162
Dimensions L x W x H (inch)	12.2 x 4.7 x 4.7	16.6 x 5.8 x 6.3	16.6 x 5.8 x 6.3
Weight (kg)	2.6	5.9	5.9
Weight (lbs)	5.73	13	13
Diameter air outlet (mm)	60	90	90
Diameter air outlet (inch)	2.36	3.54	3.54
Diameter exhaust (mm)	22	24	24
Diameter exhaust (inch)	0.87	0.94	0.94

* Boost power level for a maximum duration of 6 hrs. ** Boost power level for a maximum duration of 30 min.

Air Heaters

Application Concept

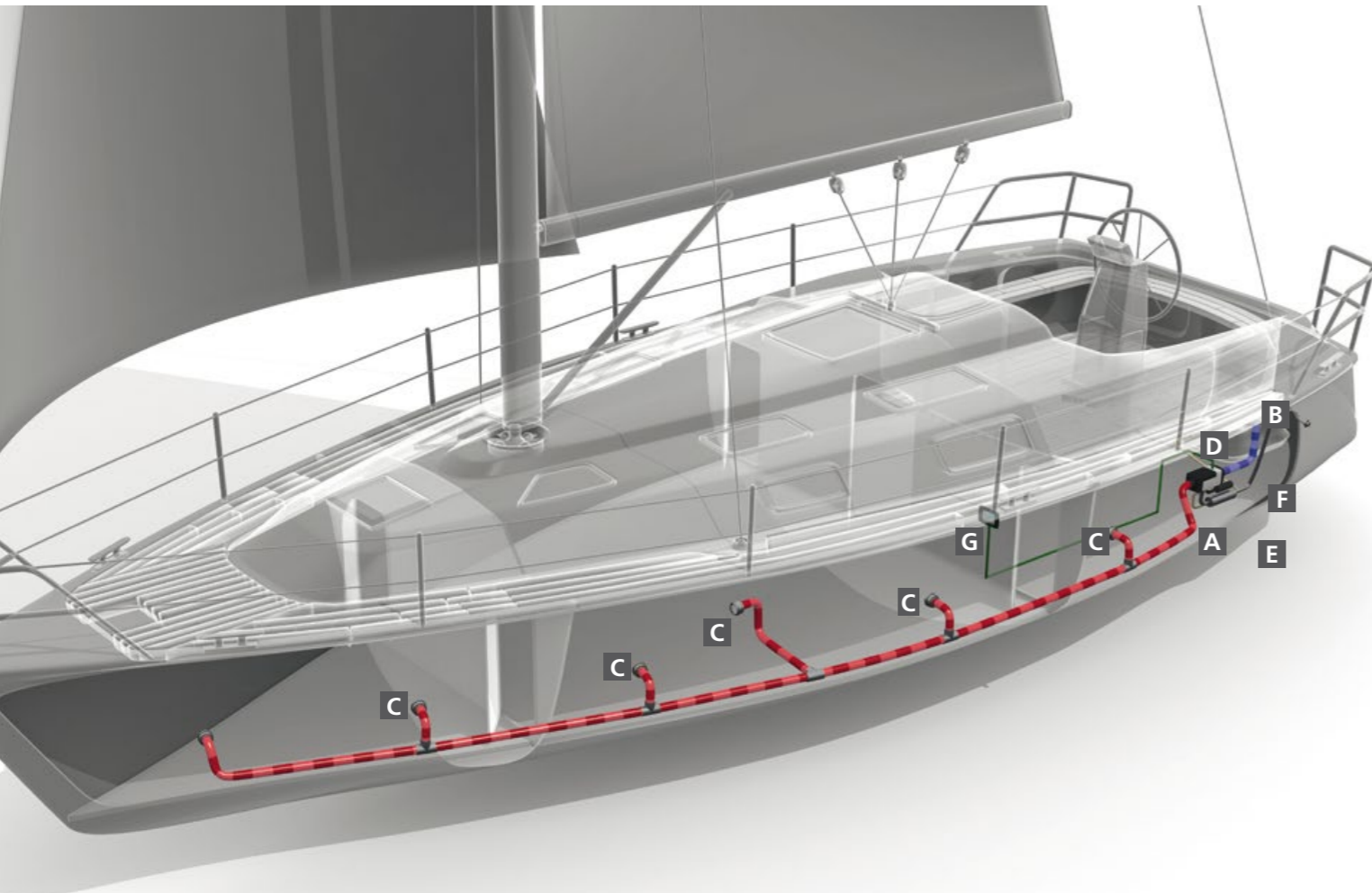

- A** Space-saving and inconspicuous installation
- B** Intake for fresh air from outside
- C** Outlets for even distribution of warm air
- D** Safe and clean: the fuel system
- E** Combustion-air intake
- F** Stainless steel exhaust
- G** Controls – simple and logical to use

Air Heaters

Selection Tool

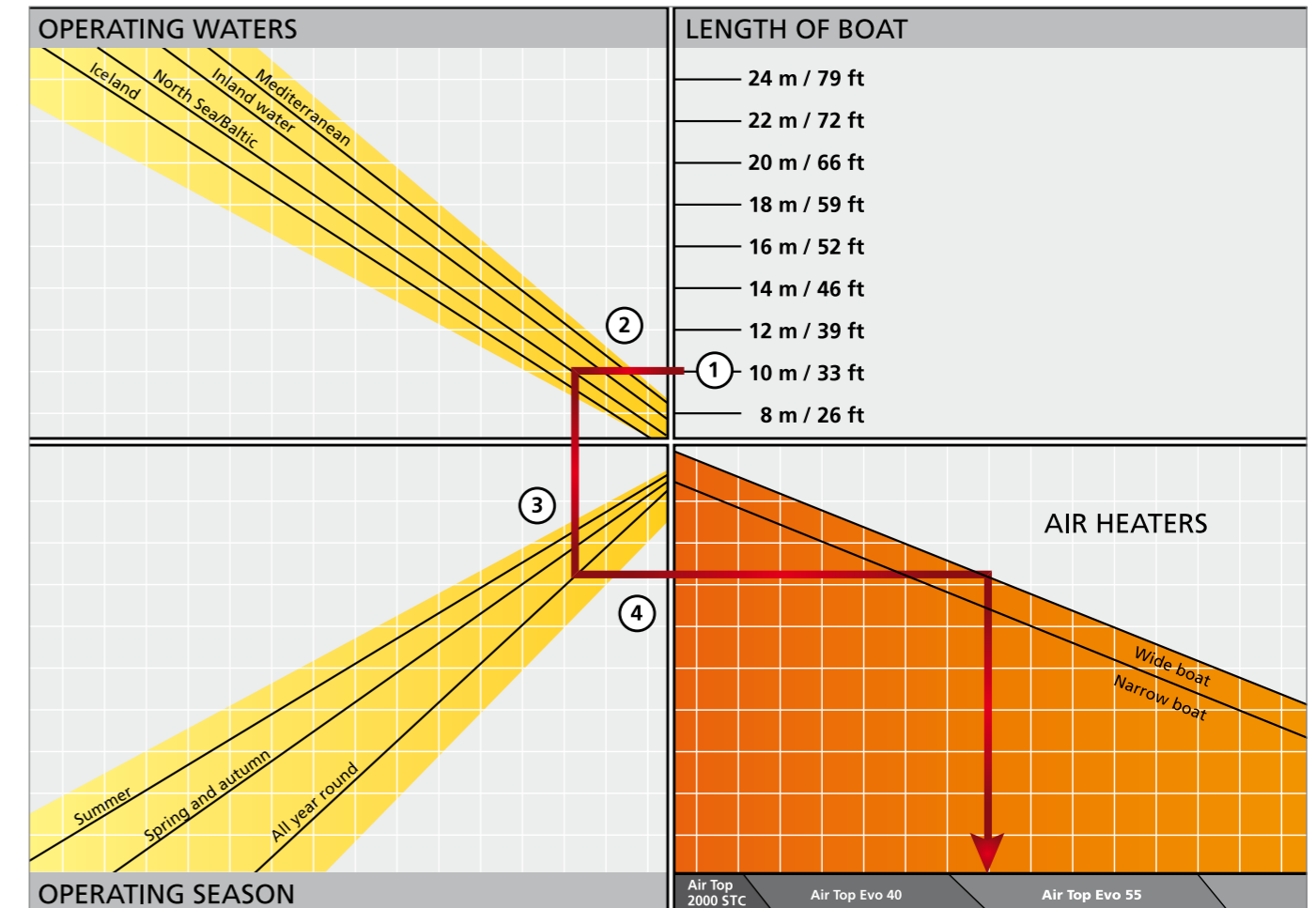

What's the Best Air Heating System for My Boat?

1. Select the length corresponding to your boat.
2. From there, trace a line to the left until you come to the line corresponding to the waters in which you plan to operate.
3. From there, trace a line vertically downwards until you come to the line corresponding to the season in which you plan to operate.
4. From there, trace a line to the right: You find the line corresponding to your type of boat in the upper section and then trace a line vertically downwards – that's the recommended system.

Air Heaters

Air Top 2000 STC



Air Top 2000 STC – quiet comfort

The quiet heater – the smallest air heater on the market. It offers excellent heat output and optimal economy.

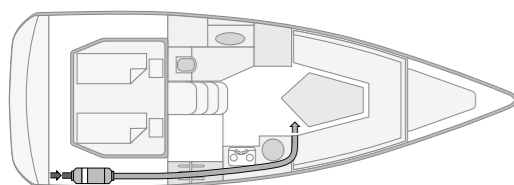

For small boats with only one main cabin, one non-closable outlet is fully sufficient.

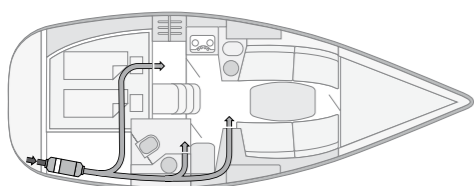

For this boat with two cabins and one head compartment one hot air outlet for each cabin is recommended. The main air duct should go into the salon and be non-closable.

The new advantages of the Air Top 2000 STC marine kits

- New split marine wiring harness with two branches to battery and cabin control
- Two ports for diagnosis and MultiControl
- Low noise fuel pump with PWM operation
- New external temperature sensor with new design
- Transparent fuel hose for easy inspection (not in U.S.)
- Easy combination with new MultiControl
- Easy to service and maintain, diagnostic capability
- Full W-bus compatibility of the heater
- Improved combustion air silencer reduces noise level

Technical specifications

	Air Top 2000 STC
EC approval mark ECE R122 (Heating)	E1 00 0216
EC approval mark ECE R10 (EMC)	E1 06 1085
Heating power, control range (kW)	0.9 – 2.0
Heating power, control range (BTU/h)	3,000 – 7,000
Fuel consumption (l/h)	0.12 – 0.24
Fuel consumption (gal/h)	0.03 – 0.06
Fuels*	Diesel DIN EN 590
Rated voltage (V)	12
Rated power consumption (W)	14 – 29
Rated current at 12 V (A)	1.2 – 2.4
Air Flow against 0.5 mbar (m³/h)	93
Air Flow against 0.5 mbar (cfm)	55
Dimensions L x W x H (mm)	310 x 120 x 118
Dimensions L x W x H (inch)	12.2 x 4.7 x 4.7
Weight (kg)	2.6
Weight (lbs)	5.73
Diameter air outlet (mm)	60
Diameter air outlet (inch)	2.36
Diameter exhaust (mm)	22
Diameter exhaust (inch)	0.87

* Information about further fuels on request.

Scopes of delivery

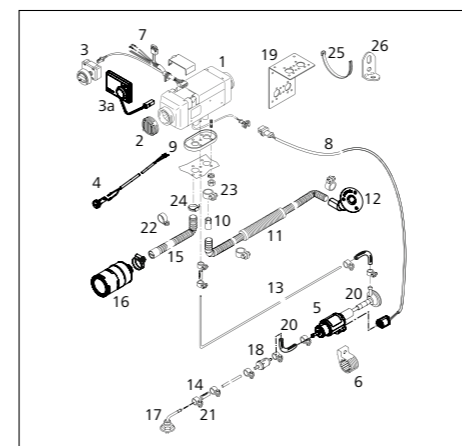

Item	Qty	Description
1	1	Heater 12 V
2	1	Grille, clips open Ø 60
3	1	Heater control element
3a	1	MultiControl
4	1	Temperature sensor, external 2.5 m
5	1	Fuel pump DP42.4 with damper
6	1	Support for fuel pump EPDM
7	1	Wiring harness with fuse holder 12/24 V
8	1	Wiring harness (fuel pump) 7,000 lg
9	1	Gasket
10	1	Exhaust gas reducing bush 22/24
11	1	Exhaust silencer, leakproof Ø 24; 1,800 lg
12	1	Exhaust through hull
13	1	Transparent fuel hose: 5,000 lg
14	5	Rubber fuel hose
15	1	Combustion air intake hose 300 lg
16	1	Combustion air intake silencer
17	1	Tank extracting device
18	1	Fuel filter
19	1	Heater bracket stainless steel
20		Vibration damper for fuel hose
1		Bag (with mech. mounting hardware) consisting of:
21	10	Hose clamp (stainless) Ø 14
22	1	Pipe clip Ø 30
23	1	Hose clamp Ø 26 – 28
24	1	Hose clamp (stainless) Ø 16 – 27
25	17	Cable tie
26	2	Angle bracket

1

Order number

9032164C

Air Top 2000 STC Marine 12 V Diesel with standard heater control element

9034777C

Air Top 2000 STC Marine 12 V Diesel with MultiControl

The Marine heater kits include high quality stainless steel parts and accessories, external temperature sensor and effective combustion and exhaust air silencers.

2

Air distribution

For the distribution of the hot air in your boat you need hoses, distributors and outlets. Please compose your air distribution system individually.

3

Fuel supply

For the installation of the heater in the engine compartment the fuel supply system has to be fire-resistant according to EN ISO 7840. Please order the adequate components additionally (fuel lines, fuel supply kit, rubber hose, fuel pump protection).

4

Exhaust system

Depending on the installation position and length of the exhaust pipe you may need a condensation water drain and an exhaust pipe insulation additionally.

5

Accessories (optional)

For extension of your heater system you find comfort control elements as well as other installation and system components in the accessories section.

Air Heaters

Air Top Evo 40



Air Top Evo 40 – the smart multi mode heater

High-output, compact and quiet, the heater is ideally suited for the most rigorous requirements. It can be upgraded with the new multi mode control panel to offer additional operation modes depending on individual heating requirements.

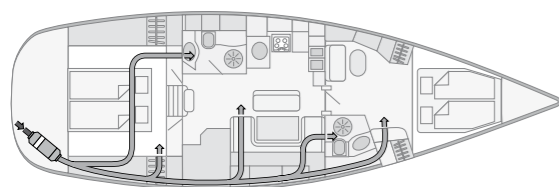

Each cabin and head compartment has its own air outlet. One outlet should be non-closable. The temperature sensor as well as the main air outlet is in the salon. The fresh air is taken in via the rear locker from outside.

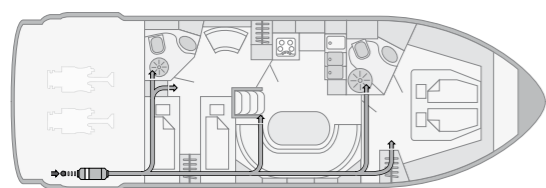

In motor boats, the heater is usually placed in the engine compartment. The fresh air has to be taken in from outside the engine room. Special attention needs to be paid to a fire-resistant fuel supply system. One of the outlets should be non-closable.

Technical specifications

	Air Top Evo 40*
EC approval mark ECE R122 (Heating)	E1 00 0385
EC approval mark ECE R10 (EMC)	E1 05 5529
Heating power, control range/boost (kW)	1.5 – 3.5/4.0*
Heating power, control range/boost (BTU/h)	5,100 – 12,000/13,600*
Fuel consumption (l/h)	0.18 – 0.43/0.49*
Fuel consumption (gal/h)	0.04 – 0.11/0.12*
Fuels**	Diesel DIN EN 590
Rated voltage (V)	12, 24
Rated power consumption (W)	15 – 40/55*
Rated current at 12 V (A)	1.3 – 3.3/4.6*
Rated current at 24 V (A)	0.6 – 1.7/2.3*
Air Flow against 0.5 mbar (m³/h)	132/140*
Air Flow against 0.5 mbar (cfm)	77.7/82.4*
Dimensions L x W x H (mm)	423 x 148 x 162
Dimensions L x W x H (inch)	16.6 x 5.8 x 6.3
Weight (kg)	5.9
Weight (lbs)	13
Diameter air outlet (mm)	90
Diameter air outlet (inch)	3.54
Diameter exhaust (mm)	24
Diameter exhaust (inch)	0.94

* Boost power level for a maximum duration of 6 hrs. ** Information about further fuels on request.

The advantages of the Air Top Evo 40:

- 4.0 kW power for fast heating
- Very low electrical power consumption due to new Intelligent Blower Control
- New flame detection through exhaust gas temperature sensor
- Automatic cold start function for quick warm-up
- Improved air intake silencer
- Vibration dampers for fuel line
- Compatible to new MultiControl digital user interface
- Very silent operation due to lower blower speed and silent fuel pump (DP42.4)

Scopes of delivery

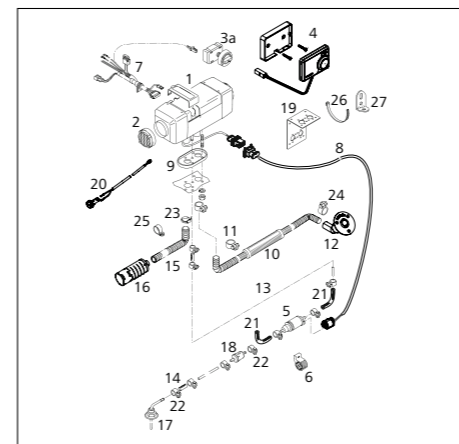

Item	Qty	Description
1	1	Heater 12 or 24 V
2	1	Grille
3a	1	Standard heater control element
4	1	MultiControl
5	1	Fuel pump DP42.4
6	1	Support for fuel pump EPDM
7	1	Wiring harness (heater); 9,500 lg
8	1	Wiring harness (fuel pump) 7,000 lg
9	1	Gasket
10	1	Exhaust silencer leakproof 1,800 lg
11	1	Hose clamp Ø 28 – 35
12	1	Exhaust through hull
13	1	Transparent fuel hose 12 V: 5,000 lg; 24 V: 8,000 lg
14	5	Rubber fuel hose
15	1	Combustion air intake hose 300 lg
16	1	Combustion air intake silencer
17	1	Tank extracting device
18	1	Fuel filter
19	1	Heater bracket stainless steel
20	1	Temperature sensor, external 2.5 m
21	2	Vibration damper for fuel hose
	1	Bag (with mech. mounting hardware) consisting of:
22	10	Hose clamp (stainless steel) Ø 14
23	1	Hose clamp Ø 16 – 27 (combustion air)
24	2	Hose clamp Ø 26 – 28 (exhaust)
25	1	Pipe clip (stainless steel) Ø 30
26	17	Cable tie
27	2	Angle bracket

1

Order number

- 9029249A**
Air Top Evo 40 Marine 12 V Diesel with standard heater control element
- 9029250A**
Air Top Evo 40 Marine 24 V Diesel with standard heater control element
- 9036994A**
Air Top Evo 40 Marine 12 V Diesel with MultiControl
- 9036995A**
Air Top Evo 40 Marine 24 V Diesel with MultiControl

The Marine heater kits include high quality stainless steel parts and accessories, long wiring harness, external temperature sensor and effective combustion and exhaust air silencers.

2

Air distribution

For the distribution of the hot air in your boat you need hoses, distributors and outlets. Please compose your air distribution system individually.

3

Fuel supply

For the installation of the heater in the engine compartment the fuel supply system has to be fire-resistant according to EN ISO 7840. Please order the adequate components additionally (fuel lines, fuel supply kit, rubber hose, fuel pump protection).

4

Exhaust system (optional)

Depending on the installation position and length of the exhaust pipe you may need a condensation water drain and an exhaust pipe insulation additionally.

5

Accessories (optional)

For extension of your heater system you find comfort control elements as well as other installation and system components in the accessories section.

Air Heaters

Air Top Evo 55



Air Top Evo 55 – for extreme conditions

Extremely powerful, compact and quiet, this heater ensures a comfortable climate for larger yachts even under the harshest conditions, and satisfies the most demanding requirements. It can be upgraded with the new multi mode user interface to offer additional operation modes depending on individual heating requirements. Two Air Top heaters can be combined into one system for increased heating demand (up to 11 kW). The whole system can be operated via one central user interface.

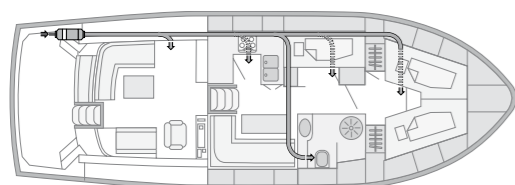

Each of this five cabin yacht has an individual air outlet. The air duct to the salon as well as the front should have at least 80 mm Ø to ensure a good air flow and one of the outlets should be non-closable. The fresh air is taken in via the rear locker from outside.

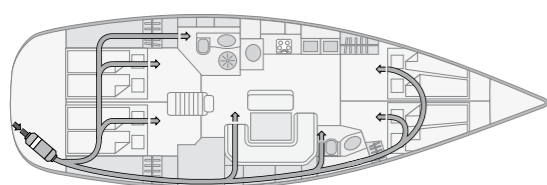

With the heater in the engine compartment, the fuel supply system must be designed to be fire-resistant. The air outlet to the salon has to be non-closable. Air outlets for the other cabins or the head compartment may be closable to enable individual heat regulation.

The advantages of the Air Top Evo 55:

- 5.5 kW power for fast heating
- Very low electrical power consumption due to new Intelligent Blower Control
- New flame detection through exhaust gas temperature sensor
- Automatic cold start function for quick warm-up
- Improved air intake silencer
- Vibration dampers for fuel line
- Compatible to new MultiControl digital user interface
- Very silent operation due to lower blower speed and silent fuel pump (DP42)

Scopes of delivery

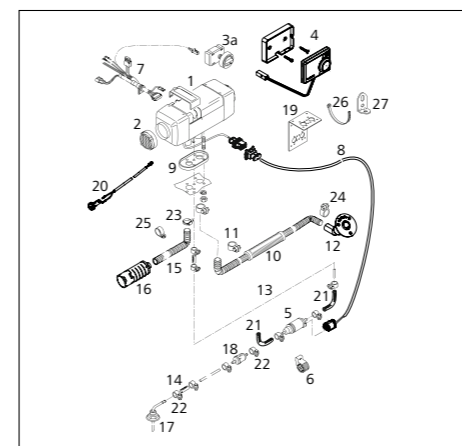

Item	Qty	Description
1	1	Heater 12 or 24 V
2	1	Grille
3a	1	Standard heater control element
4	1	MultiControl
5	1	Fuel pump DP42.4
6	1	Support for fuel pump EPDM
7	1	Wiring harness (heater); 9,500 lg
8	1	Wiring harness (fuel pump) 7,000 lg
9	1	Gasket
10	1	Exhaust silencer leakproof 1,800 lg
11	1	Hose clamp Ø 28 – 35
12	1	Exhaust through hull
13	1	Fuel hose 12 V: 5,000 lg; 24 V: 8,000 lg
14	5	Rubber fuel hose
15	1	Combustion air intake hose 300 lg
16	1	Combustion air intake silencer
17	1	Tank extracting device
18	1	Fuel filter
19	1	Heater bracket stainless steel
20	1	Temperature sensor, external 2.5 m
21	2	Vibration damper for fuel hose
	1	Bag (with mech. mounting hardware) consisting of:
22	10	Hose clamp (stainless steel) Ø 14
23	1	Hose clamp Ø 16 – 27 (combustion air)
24	2	Hose clamp Ø 26 – 28 (exhaust)
25	1	Pipe clip (stainless steel) Ø 30
26	17	Cable tie
27	2	Angle bracket

Technical specifications

	Air Top Evo 55*
EC approval mark ECE R122 (Heating)	E1 00 0386
EC approval mark ECE R10 (EMC)	E1 05 5529
Heating power, control range/boost (kW)	1.5 – 5.0/5.5*
Heating power, control range/boost (BTU/h)	5,100 – 17,000/18,800*
Fuel consumption (l/h)	0.18 – 0.61/0.67*
Fuel consumption (gal/h)	0.04 – 0.15/0.17*
Fuels**	Diesel DIN EN 590
Rated voltage (V)	12, 24
Rated power consumption (W)	15 – 95/130*
Rated current at 12 V (A)	1.3 – 7.9/10.8*
Rated current at 24 V (A)	0.6 – 4.0/5.4*
Air Flow against 0.5 mbar (m³/h)	200/220*
Air Flow against 0.5 mbar (cfm)	117.7/129.5*
Dimensions L x W x H (mm)	423 x 148 x 162
Dimensions L x W x H (inch)	16.6 x 5.8 x 6.3
Weight (kg)	5.9
Weight (lbs)	13
Diameter air outlet (mm)	90
Diameter air outlet (inch)	3.54
Diameter exhaust (mm)	24
Diameter exhaust (inch)	0.94

* Boost power level for a maximum duration of 30 min. ** Information about further fuels on request.

1

Order number

- 9029256A**
Air Top Evo 55 Marine 12 V Diesel with standard heater control element
- 9029257A**
Air Top Evo 55 Marine 24 V Diesel with standard heater control element
- 9036996A**
Air Top Evo 55 Marine 12 V Diesel with MultiControl
- 9036998A**
Air Top Evo 55 Marine 24 V Diesel with MultiControl

The Marine heater kits include high quality stainless steel parts and accessories, long wiring harness, external temperature sensor and effective combustion and exhaust air silencers.

2

Air distribution

For the distribution of the hot air in your boat you need hoses, distributors and outlets. Please compose your air distribution system individually.

3

Fuel supply

For the installation of the heater in the engine compartment the fuel supply system has to be fire-resistant according to EN ISO 7840. Please order the adequate components additionally (fuel lines, fuel supply kit, rubber hose, fuel pump protection).

4

Exhaust system (optional)

Depending on the installation position and length of the exhaust pipe you may need a condensation water drain and an exhaust pipe insulation additionally.

5

Accessories (optional)

For extension of your heater system you find comfort control elements as well as other installation and system components in the accessories section.

Water Heaters

Thermo Pro 90: The renowned

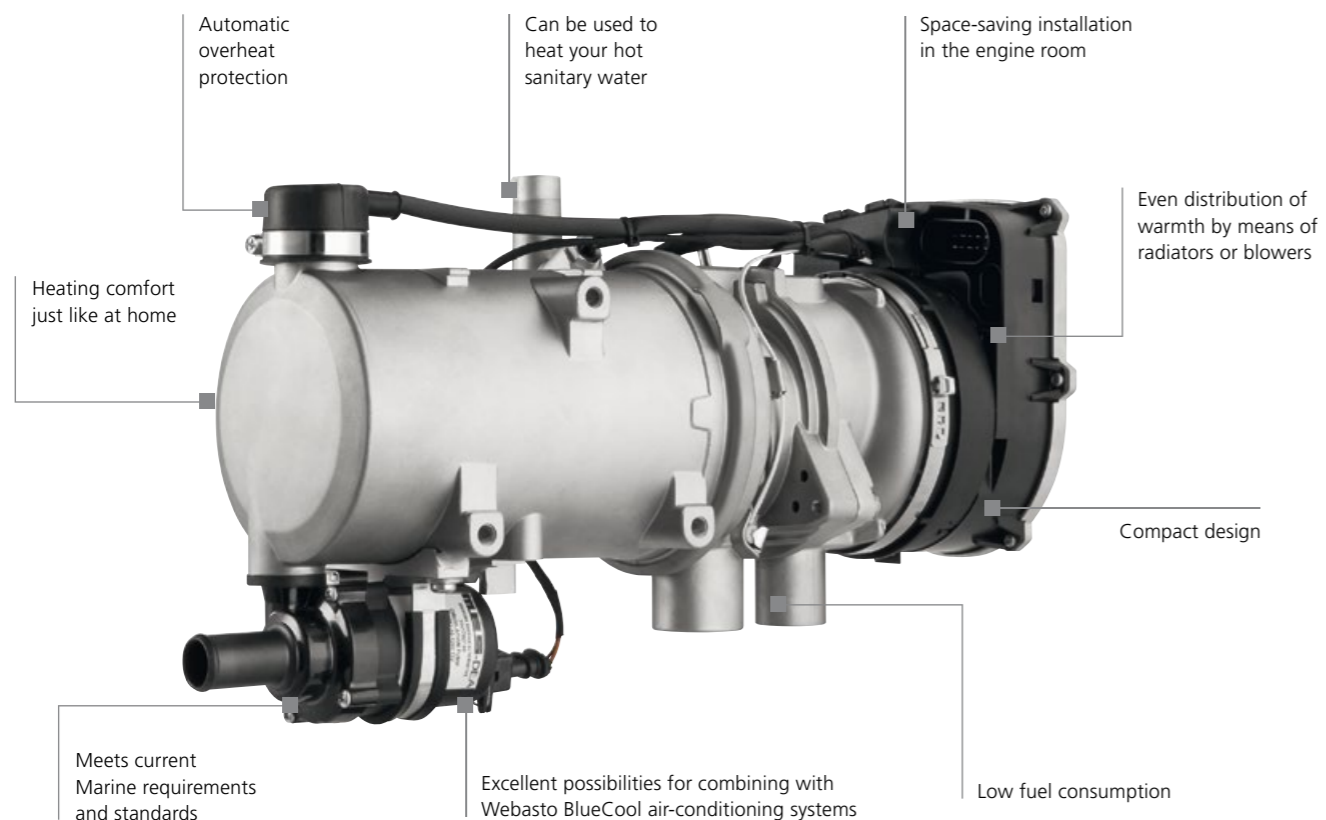

Water Heaters Product Overview



Thermo Top Evo
Thermo Pro 50 Eco

See page 30

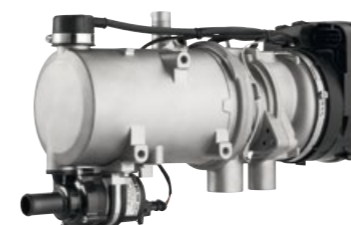

Thermo Pro 90

See page 32



Thermo Top Pro 120/150

See page 34



Greater comfort with our innovative Webasto ThermoConnect TCon2. Run your water or air heater easily with a smartphone.

Water Heaters

Product Overview

	Part no.		EC approval mark	Heat output		Fuel, Fuel consumption	Rated voltage	Rated power consumption		Flow rate of coolant pumps	Dimensions heater (L x W x H)	Dimensions control unit with mounting (L x W x H)	Weight heater incl. fuel pump
	12 V Diesel	24 V Diesel		part load	full load			part load	full load				
Thermo Top Evo Marine	9042322A	–	E1 00 0258 (ECE R122) E1 04 5627 (ECE R10)	1.8 kW 6,100 BTU/h	5.0 kW 17,100 BTU/h	Diesel, 0.22–0.62 l/h Diesel, 0.06–0.16 gal/h	12 V	10 W 0.8 amps	33 W 2.7 amps	500 l/h against 0.14 bar 2.2 gal/min.	218 x 91 x 147 mm 8.6 x 3.6 x 5.8 inch	68 x 48 x 15 mm 2.7 x 1.9 x 0.6 inch	2.1 kg 4.6 lbs
Thermo Pro 50 Eco Marine	–	9028080E	E1 00 0471 (ECE R122) E1 06 7609 (ECE R10)	2.5 kW 8,500 BTU/h	5.0 kW 17,100 BTU/h	Diesel, 0.30–0.60 l/h Diesel, 0.08–0.16 gal/h	24 V	28 W 1.2 amps	46 W 1.9 amps	500 l/h against 0.14 bar 2.2 gal/min.	218 x 91 x 144 mm 8.6 x 3.6 x 5.7 inch	–	2.2 kg 4.9 lbs
Thermo Pro 90 Marine	9029940C	9029941C	E1 00 0320 (ECE R122) E1 04 6196 (ECE R10)	1.8–7.6 kW 6,100–26,000 BTU/h	9.1 kW 31,000 BTU/h	Diesel 0.18–1.08/1.3 l/h Diesel 0.05–0.24/0.34 gal/h	12 V, 24 V	20–83 W 3.0–6.9 amps at 12 V 1.5–3.5 amps at 24 V	90 W 7.5 amps at 12 V 3.8 amps at 24 V	700 l/h against 0.3 bar 3.1 gal/min.	385 x 131 x 232 mm 15.2 x 5.2 x 9.1 inch	134 x 53 x 90 mm	5.3 kg 11.7 lbs
Thermo Pro 90 Chiller	9029942C	9029943C	E1 00 0320 (ECE R122) E1 04 6196 (ECE R10)	1.8–7.6 kW 6,100–26,000 BTU/h	9.1 kW 31,000 BTU/h	Diesel 0.18–1.08/1.3 l/h Diesel 0.05–0.24/0.34 gal/h	12 V, 24 V	20–83 W 3.0–6.9 amps at 12 V 1.5–3.5 amps at 24 V	90 W 7.5 amps at 12 V 3.8 amps at 24 V	–	385 x 131 x 219 mm 15.2 x 5.2 x 8.6 inch	134 x 53 x 90 mm	4.9 kg 10.8 lbs
Thermo Top Pro 120	9035585A	9035584A	E1 00 0480, E1 00 0481 (ECE R122) E1 05 7735 (ECE R10)	12.0 kW 40,950 BTU/h		Diesel, 1.6 l/h Diesel, 0.42 gal/h	12 V, 24 V	80 W 6.7 amps at 12 V 3.3 amps at 24 V		1,500 l/h against 0.56 bar 6.6 gal/min.	470 x 200 x 200 mm 18.5 x 7.9 x 7.9 inch	–	11.7 kg 25.7 lbs
Thermo Top Pro 120 Chiller	–	9042807A	E1 00 0480, E1 00 0481 (ECE R122) E1 05 7735 (ECE R10)	12.0 kW 40,950 BTU/h		Diesel, 1.6 l/h Diesel, 0.42 gal/h	24 V	80 W 3.3 amps at 24 V		–	470 x 200 x 200 mm 18.5 x 7.9 x 7.9 inch	–	11.7 kg 25.7 lbs
Thermo Top Pro 150	9035583A	9035582A	E1 00 0480, E1 00 0481 (ECE R122) E1 05 7735 (ECE R10)	15.0 kW 51,180 BTU/h		Diesel, 1.7 l/h Diesel, 0.45 gal/h	12 V, 24 V	100 W 8.3 amps at 12 V 4.2 amps at 24 V		1,500 l/h against 0.56 bar 6.6 gal/min.	470 x 200 x 200 mm 18.5 x 7.9 x 7.9 inch	–	11.7 kg 25.7 lbs



Thermo Top Evo Marine



Thermo Pro 90 Marine



Thermo Top Pro 120/150

Water Heaters

Application Concept

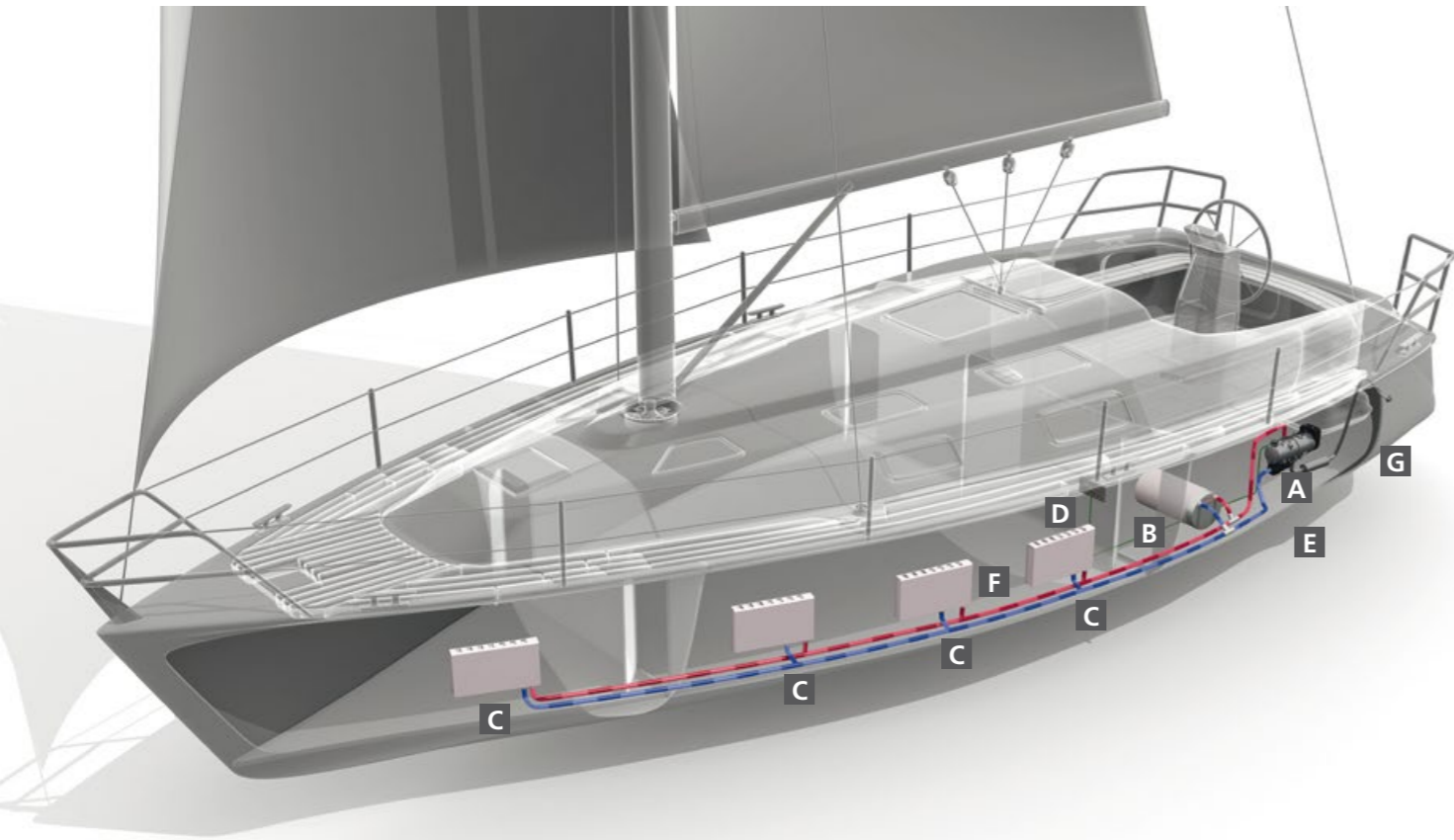

- A** Space-saving and inconspicuous installation in the engine room
- B** Boiler for heating hot water – for extra comfort
- C** One radiator for each cabin allows an individual temperature control
- D** Controls – simple and logical to use
- E** Coolant pump
- F** Fresh water tank
- G** Stainless steel exhaust

Water Heaters

Selection Tool

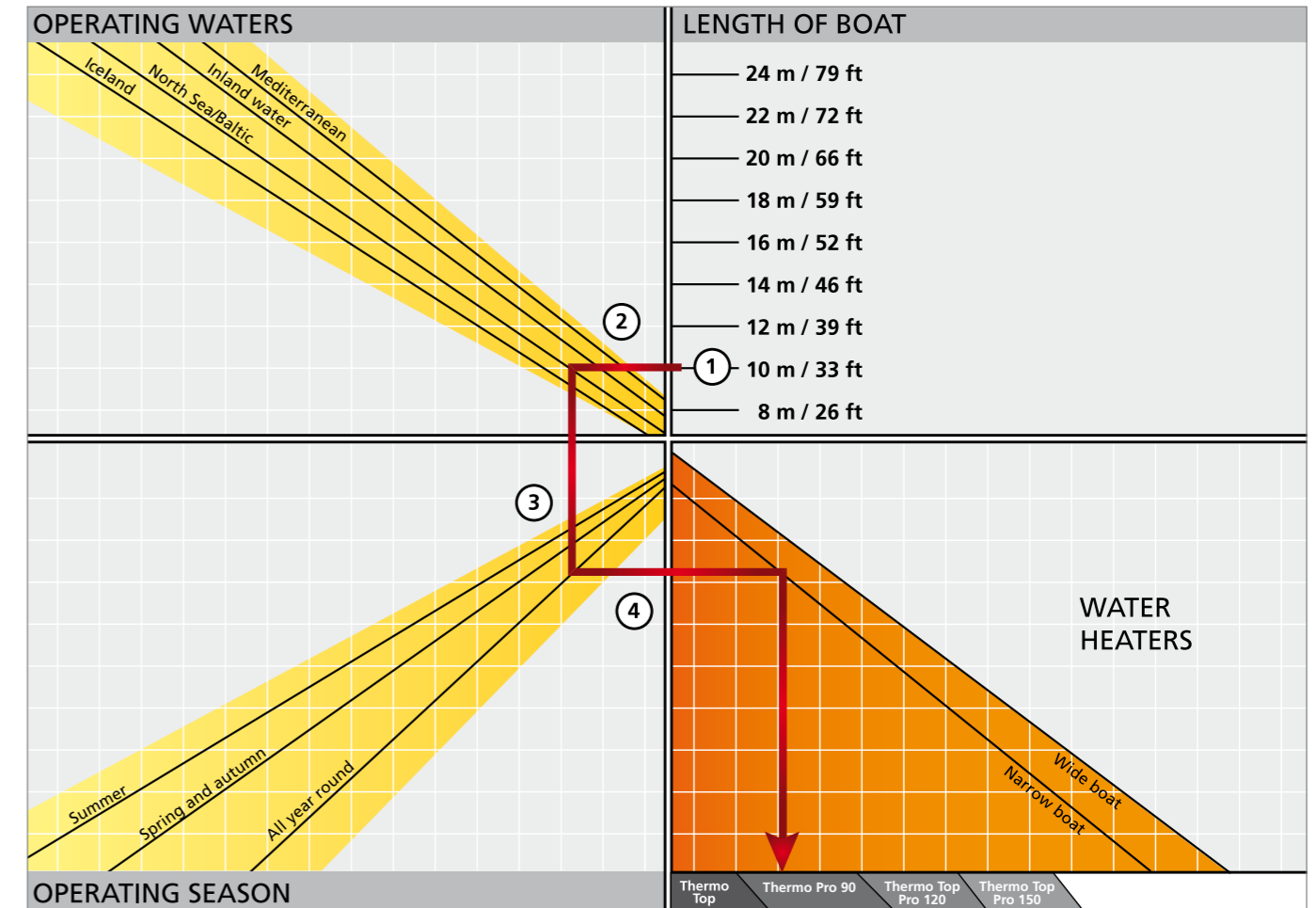

What's the Best Water Heating System for My Boat?

1. Select the length corresponding to your boat.
2. From there, trace a line to the left until you come to the line corresponding to the waters in which you plan to operate.
3. From there, trace a line vertically downwards until you come to the line corresponding to the season in which you plan to operate.
4. From there, trace a line to the right: Select the line corresponding to your type of boat in the lower section and then trace a line vertically downwards – that's the recommended system.

Water Heaters

Thermo Top Evo/Thermo Pro 50 Eco



Thermo Top water heaters

This compact 5 kW unit is ideal for the majority of marine applications. Compact design, variable temperature control, service friendly technology and low noise levels.

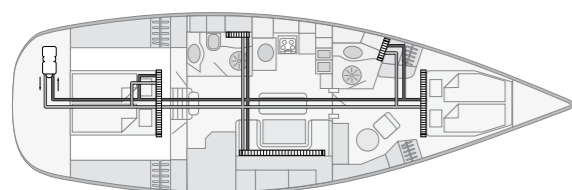

The Thermo Top Evo is placed in the locker compartment of the boat. Radiators are used to heat up the boat, because electrical autonomy in this size of boat is often very important and radiators do not consume electricity of the battery.

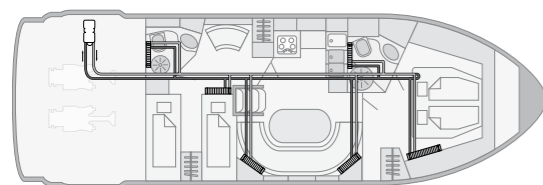

The Thermo Top Evo in the engine compartment is able to heat the entire boat. Each cabin has individually sized convectors to match the heating requirements.

Technical specifications

	Thermo Top Evo	Thermo Pro 50 Eco
EC approval mark ECE R122 (Heating)	E1 00 0258	E1 00 0471
EC approval mark ECE R10 (EMC)	E1 04 5627	E1 06 7609
Heating power (kW)	5.0	5.0
Heating power (BTU/h)	17,100	17,100
Fuel consumption (l/h)	0.22 – 0.62	0.3 – 0.6
Fuel consumption (gal/h)	0.06 – 0.16	0.08 – 0.16
Fuels*	Diesel DIN EN 590	Diesel DIN EN 590
Rated voltage (V)	12	24
Rated power consumption (W)	10 – 33	28 – 46
Rated power consumption (amps)	2.7 – 3.5	1.2 – 1.9
Flow rate of coolant pump (against 0.14 bar) (l/h)	500	500
Flow rate of coolant pump (against 0.14 bar) (gal/min.)	2.2	2.2
Flow rate of coolant pump (against 0.10 bar) (l/h)	–	900
Flow rate of coolant pump (against 0.10 bar) (gal/min.)	–	4
Dimensions L x W x H (mm)	218 x 91 x 147	218 x 91 x 144
Dimensions L x W x H (inch)	8.6 x 3.6 x 5.8	8.6 x 3.6 x 5.7
Weight (kg)	2.1	2.2
Weight (lbs)	4.6	4.9

* Information about further fuels on request.

The advantages of water heaters:

- Even distribution of warmth by means of radiators
- Hot water for the shower and galley
- Space-saving installation
- Excellent possibilities for combining with Webasto BlueCool air-conditioning systems
- Separate temperature control in every cabin
- Low fuel consumption
- Preheating of the engine possible to avoid cold starts
- Robust aluminum casing, resistant to high temperature or salt

What is the new generation about?

- Stepless heating power adjustment between 1.8 and 5 kW
- Less start-stops
- Exhaust temperature control for optimized environmental conditions
- Mainswitch with blinking code (analog control)

Scopes of delivery

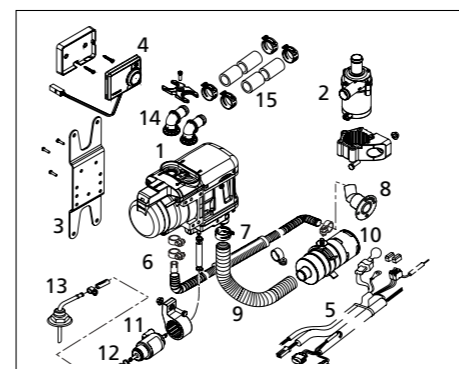

Item	SOD	Description
1	■	Heater
2	■	Coolant pump U4847 with fixation
3	■	Heater bracket
4	■	MultiControl with bracket
5	■	Wiring harness
6	■	Exhaust reducer
7	■	Exhaust silencer
8	■	Exhaust through hull
9	■	Combustion air pipe
10	■	Air intake silencer
11	■	Fuel pump DP42.4 with fixation
12	■	Fuel hose
13	■	Tank extracting device
14	■	Coolant connection piece
15	■	Coolant hose
	■	Mounting parts

1

Order number

9042322A

Thermo Top Evo Marine Classic 12 V Diesel

9028080E

Thermo Pro 50 Eco Marine 24 V Diesel

2

Water system

For the distribution of heat in your boat you may need extra hoses, valves, expansion tank, convectors, air handlers etc. Please compose your water system individually.

3

Fuel supply

For the installation of the heater in the engine compartment the fuel supply system has to be fire-resistant according to EN ISO 7840. Please order the adequate components additionally (fuel lines, fuel supply kit, rubber hose, fuel pump protection).

4

Exhaust system

Depending on the installation position coolant pump and length of the exhaust pipe you may need a condensation water drain and an exhaust pipe insulation additionally.

5

Accessories (optional)

For extension of your heater system you find comfort control elements as well as other installation and system components in the accessories section.

Water Heaters

Thermo Pro 90/Thermo Pro 90 Chiller



Thermo Pro 90 Marine – State-of-the Art Controller and Easy Service

This device is ideal for daily use: infinitely variable power adjustment, high heat output, compact dimensions, service-friendly technology and an extremely low noise level.

Thermo Pro 90 Chiller – the heater for integration into an A/C system

If you want to build a BlueComfort system with a Thermo 90 heater, use the Thermo Pro 90 Chiller version. It comes with a special electronic control unit and without the water pump which is not needed.

The advantages of the Thermo Pro 90:

- Ideal for daily use
- Infinitely variable power adjustment
- High heat output
- Compact dimensions
- Service friendly technology
- Extremely low noise level

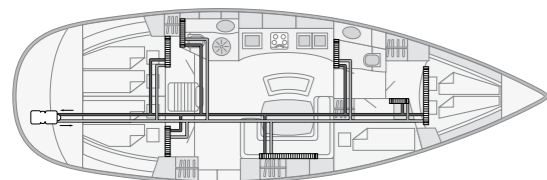

This 44' sailing yacht uses convectors for all cabins to heat the boat. Convectors are noiseless and do not consume any electrical power off the battery, therefore resulting in a very high electrical autonomy.

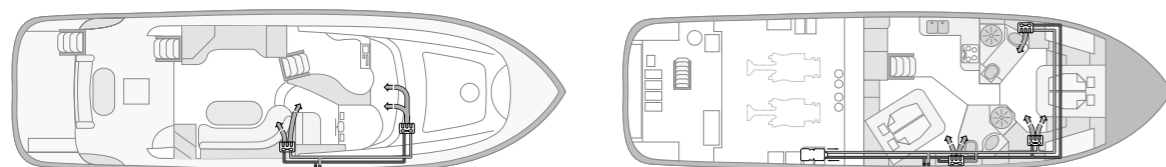

In this 40' motor yacht electrical fan blowers are used to heat up the boat. They are very compact and may be easily installed in small spaces, blowing hot air through air ducts into each cabin. The windscreen has a separate blower to demist and defrost.

Technical specifications

	Thermo Pro 90	Thermo Pro 90 Chiller
EC approval mark ECE R122 (Heating)	E1 00 0320	E1 00 0320
EC approval mark ECE R10 (EMC)	E1 04 6196	E1 04 6196
Heating power, control range/boost (kW)	1.8 – 7.6/9.1	1.8 – 7.6/9.1
Heating power, control range/boost (BTU/h)	6,100 – 26,000/31,000	6,100 – 26,000/31,000
Fuel consumption, control range/boost (l/h)	0.18 – 1.08/1.3	0.18 – 1.08/1.3
Fuel consumption, control range/boost (gal/h)	0.05 – 0.24/0.34	0.05 – 0.24/0.34
Fuels*	Diesel DIN EN 590	Diesel DIN EN 590
Rated voltage (V)	12, 24	12, 24
Rated power consumption, control range/boost (W)	20 – 83/90	20 – 83/90
Rated power consumption, control range/boost (amps)	3.0 – 6.9 amps/7.5 at 12 V, 1.5 – 3.5/3.8 at 24 V	3.0 – 6.9 amps/7.5 at 12 V, 1.5 – 3.5/3.8 at 24 V
Flow rate of coolant pump (against 0.3 bar) (l/h)	700	–
Flow rate of coolant pump (against 0.3 bar) (gal/min.)	3.1	–
Dimensions L x W x H (mm)	352 x 131 x 232	385 x 131 x 219
Dimensions L x W x H (inch)	13.9 x 5.2 x 9.1	15.2 x 5.2 x 8.6
Weight (kg)	5.3	4.9
Weight (lbs)	11.7	10.8

* Information about further fuels on request.

Scopes of delivery

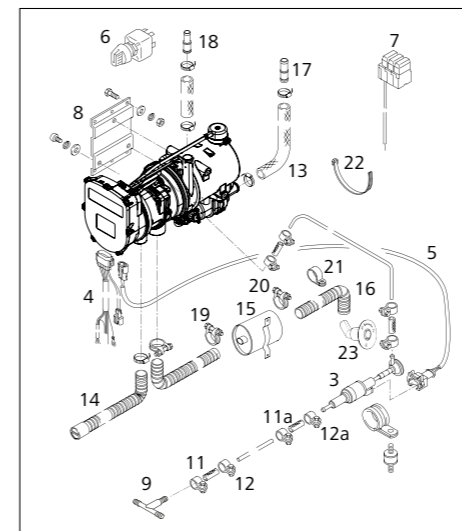

Item	Qty	Description
1	1	Heater 12 or 24 V including coolant pump U4840 and electronic control unit (no coolant pump with Thermo Pro 90 Chiller)
2	1	Electronic control unit
3	1	Fuel pump DP42.4
4	1	Wiring harness (heater, 570 lg)
5	1	Wiring harness (fuel pump, 5,000 lg)
6	1	Switch with lamp 12 or 24 V (not with 9029942A and 9029943A)
7	1	Fuse holder with wiring harness
8	1	Heater bracket
9	1	T-piece + fuel hoses & hose clamps (8 x 5 x 8)
10	1	Hose Ø 5 x 1.5; 6,000 lg
11	4	Fuel hose Øi 4.5/Øa 10.5; 50 lg
11a	2	Fuel hose Øi 8/Øa 12; 70 lg
12	8	Hose clamp (steel; Ø 10)
12a	4	Hose clamp (steel; Ø 12)
13	1	Bent hose Øi 20 / Øa 29; 2,200 lg
14	1	Air intake silencer PAK Øi 30,5/Øa 38; 1,160 lg
15	1	Exhaust silencer Øa 38
16	1	Flexible pipe (inoxid.) Øi 38/Øa 42; 1,600 lg (1 x 1,000 mm + 1 x 600 mm)
17	2	Connection pipe Ø 18 x 20
18	2	Connection pipe Ø 20 x 20
19	7	Hose clamp Ø 23 ... 35
20	3	Hose clamp Ø 39 ... 42
21	2	Pipe clip Ø 42
22	15	Cable tie 178 lg
23	1	Exhaust through hull

- Order number
9029940C
 Thermo Pro 90 Marine 12 V Diesel
9029941C
 Thermo Pro 90 Marine 24 V Diesel
9029942C
 Thermo Pro 90 Chiller 12 V Diesel
9029943C
 Thermo Pro 90 Chiller 24 V Diesel

- Water system**
 For the distribution of heat in your boat you may need extra hoses, valves, expansion tank, convectors, air handlers etc. Please compose your water system individually.

- Fuel supply**
 For the installation of the heater in the engine compartment the fuel supply system has to be fire-resistant according to EN ISO 7840. Please order the adequate components additionally (fuel lines, fuel supply kit, rubber hose, fuel pump protection).

- Exhaust system**
 Depending on the installation position and length of the exhaust pipe you may need a condensation water drain and an exhaust pipe insulation additionally.

- Control element**
 Please order an adequate control element. For the Thermo Pro 90 Chiller no control element is needed. The heater is activated via the air-conditioning control.

- Accessories (optional)**
 For extension of your heater system you find comfort control elements as well as other installation and system components in the accessories section.

Water Heaters

Thermo Top Pro 120/150



Greater performance and innovation in terms of customer comfort & safety

The Thermo Top Pro 120 and Thermo Top Pro 150 constitute a new generation of water heaters in the high-performance categories of 12 and 15 kW. The powerful heaters are each available in 12 and 24 V versions and are also suited for use in marine environment.

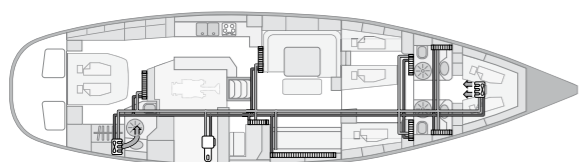

In this 64' sailing yacht the heater is installed in the technical compartment. Mainly convectors are used as heat exchangers. Fan blowers are only used in cabins with space restrictions or where quick heating up or air circulation is required.

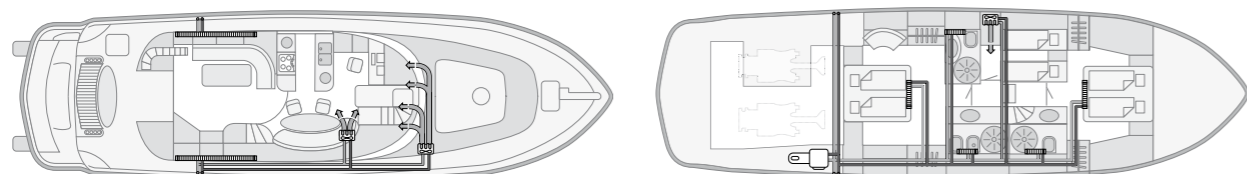

The heater in this 50' motor yacht provides heating for both decks. A combination of convectors and fan blowers is used.

The advantages of the Thermo Top Pro 120/150:

- Small, light and lean design
- Conventional diesel fuel and 100% paraffinic diesel fuel (incl. renewable fuels, such as HVO)
- ECU and all connections on one side
- Easy to reach plugs for a fast installation
- Low noise emission
- More safety and diagnostic functions
- New, powerful coolant pump U4850

Scopes of delivery

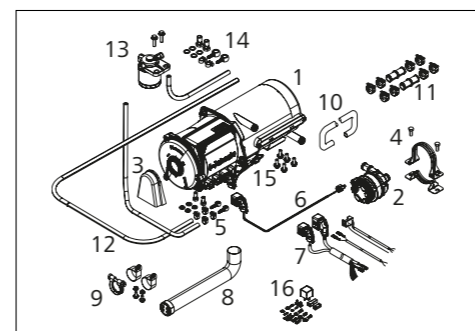

Contents Scope of delivery/ Installation kit

Part	SOD Basic	SOD Chiller	IK*	Description
1	■	■		Heater
2	■			Coolant pump U4850
3	■	■		Splash guard
4	■			Bracket coolant pump
5	■	■		Mounting material fuel
6			■	Wiring harness coolant pump
7		■	■	Wiring harness vehicle, vehicle fan, fuse holder
8		■	■	Exhaust flex pipe**
9		■	■	Mounting material exhaust**
10			■	Coolant hose
11			■	Mounting material coolant
12		■	■	Fuel hose
13		■	■	Fuel filter
14		■	■	Mounting material fuel filter
15		■	■	Mounting material heater
16		■	■	Mounting material electric
		■	■	Further mounting material
	■	■		Technical documentation

* Only for SOD Basic, not for SOD Chiller

** For marine application additional exhaust system components necessary

Technical specifications

	Thermo Top Pro 120	Thermo Top Pro 150
EC approval mark ECE R122 (Heating)	E1 00 0480, E1 00 0481	E1 00 0480, E1 00 0481
EC approval mark ECE R10 (EMC)	E1 05 7735	E1 05 7735
Heating power (kW)	12.0	15.0
Heating power (BTU/h)	40,950	51,180
Fuel consumption (l/h)	1.6	1.7
Fuel consumption (gal/h)	0.42	0.45
Fuels*	Diesel DIN EN 590	Diesel DIN EN 590
Rated voltage (V)	12, 24	12, 24
Rated power consumption (W)	80 6.7 amps at 12 V 3.3 amps at 24 V	100 8.3 amps at 12 V 4.2 amps at 24 V
Flow rate of coolant pump (against 0.56 bar) (l/h)	1,500	1,500
Flow rate of coolant pump (against 0.56 bar) (gal/min.)	6.6	6.6
Dimensions L x W x H (mm)	470 x 200 x 200	470 x 200 x 200
Dimensions L x W x H (inch)	18.5 x 7.9 x 7.9	18.5 x 7.9 x 7.9
Weight (kg)	11.7	11.7
Weight (lbs)	25.7	25.7

* Information about further fuels on request.

1

Order number

- 9035585A**
Thermo Top Pro 120 Basic 12 V Diesel
- 9035584A**
Thermo Top Pro 120 Basic 24 V Diesel
- 9035583A**
Thermo Top Pro 150 Basic 12 V Diesel
- 9035582A**
Thermo Top Pro 150 Basic 24 V Diesel
- 9042807A**
Thermo Top Pro 120 Chiller 24 V Diesel

2

Installation kit

- 9035492A**
Installation kit 12 V Standard
- 9035160A**
Installation kit 24 V Standard

3

Water system

For the distribution of heat in your boat you may need extra hoses, valves, expansion tank, convectors, air handlers etc. Please compose your water system individually.

4

Fuel supply

Please compose the adequate system components for your boat individually. For the installation of the heater in the engine compartment the fuel supply system has to be fire-resistant according to EN ISO 7840.

5

Exhaust system

Please order exhaust hose, the exhaust silencer and skin fitting additionally. Depending on the installation position and length of the exhaust pipe you may need a condensation water drain and an exhaust pipe insulation additionally.

6

Accessories (optional)

For extension of your heater system you find comfort control elements as well as other installation and system components in the accessories section.

Isotemp Hot Water Boilers



Isotemp water heaters

The Isotemp water heaters deliver high water heating performances thanks to thick insulation and smart design. Indeed, the engine water heat exchanger as well as the electrical heat element are positioned in the lowest part of the tank where the water is coldest in order to ensure an equal heating of all the water in the tank. The water in- and outlets are especially designed to minimize the mixture of cold and hot water.

Product specifications:

- Large range from 15 liter to 75 liter
- 4 product lines: Basic, Slim, Square, Spa
- Extra long, corrugated coils for high heat exchange efficiency
- Special 6.0 or 7.0 bar safety valve; simple winter drain
- Ultra-thick insulation for lowest temperature loss
- Electrical plug and play
- Immersion heating element especially designed to heat also the water at the bottom of the tank
- Thermostat mixing valve standard on Basic and Slim; optional on Square and Spa
- Immersion heating element optional available in 750; 1,200; 2,000 W; 2,000 W heating element is compatible on 230 V versions only

Isotemp Double Coil boilers are the perfect option to be integrated into Webasto water heating systems. Select among three models: Basic 24 double coil, Basic 40 double coil or Basic 75 double coil.



Basic



Slim



Spa



Square 16

Type	Order number	Volume (l)	L x diameter D (mm)	Weight (kg)	Max. pressure	Valve			Immersion heater				
						Standard safety without mixing valve	LK safety without mixing valve	LK safety with mixing valve	230 V 750 W	230 V 1200 W	230 V 2000 W	115 V 750 W	115 V 1200 W
Basic													
Basic 24	602431B000003	24	470 x 395	12.5	7	-	-	■	■	-	-	○	-
Basic 30	603031B000003	30	535 x 395	13.5	7	-	-	■	■	-	-	○	-
Basic 40	604031B000003	40	640 x 395	15.5	7	-	-	■	■	○	-	○	○
Basic 50	605031B000003	50	760 x 395	17	7	-	-	■	■	○	○	○	○
Basic 75	607531B000003	75	1,050 x 395	24.5	7	-	-	■	■	○	○	○	○
Basic Double Coil													
Basic 24 Double Coil	602431BD000003	24	470 x 395	13	7	-	-	■	■	-	-	○	-
Basic 40 Double Coil	604031BD000003	40	640 x 395	16	7	-	-	■	■	○	-	○	○
Basic 75 Double Coil	607531BD000003	75	1,050 x 395	25	7	-	-	■	■	○	○	○	○
Slim													
Slim 15	601531S000003	15	520 x 295	9	7	-	-	■	■	-	-	○	-
Slim 20	IM602031S000003	20	645 x 295	10.5	7	-	-	■	■	○	-	○	○
Slim 25	602531S000003	25	765 x 295	12	7	-	-	■	■	○	○	○	○
Spa													
SPA 15	6P1531SPA0100	15	450 x 310	7.5	6	■	-	-	■	-	-	○	-
SPA 15 LK MV	6P1531SPA0003	15	450 x 310	8	6	-	-	■	■	-	-	○	-
SPA 20	6P2031SPA0100	20	550 x 310	9	6	■	-	-	■	-	-	○	-
SPA 20 LK MV	6P2031SPA0003	20	550 x 310	9.5	6	-	-	■	■	-	-	○	-
SPA 25	6P2531SPA0100	25	650 x 310	10	6	■	-	-	■	○	○	○	○
SPA 25 LK MV	6P2531SPA0003	25	650 x 310	10.5	6	-	-	■	■	○	○	○	○
SPA 30	6P3031SPA0100	30	535 x 390	12	6	■	-	-	■	-	-	○	-
SPA 30 LK MV	6P3031SPA0003	30	535 x 390	12	6	-	-	■	■	-	-	○	-
SPA 40	6P4031SPA0100	40	640 x 390	14	6	■	-	-	■	○	-	○	○
SPA 40 LK MV	6P4031SPA0003	40	640 x 390	14	6	-	-	■	■	○	-	○	○
Square													
Dimension L x H x W (mm)													
Square 16 LK	IM601631QX00000A	16	400 x 180 x 560	15	5	-	■	-	■	-	-	○	-
Square 16 LK MV	IM601631QX00003AA	16	400 x 180 x 560	15.5	5	-	-	■	■	-	-	○	-

■ Standard ○ Optional - Not available



Accessories for Heating Systems

Coolant Pumps	40
Control Elements	42
Combustion Air Line	46
Exhaust System	47
Fuel System	51
Hot Air System	54
Blower Heat Exchangers	70
Water System	72
Valve	78
Mounting Parts	80
Electrical Accessories	83
Maintenance and Diagnostics	84

Coolant Pumps

Technical features

These coolant pumps are suitable for hot water circulation. They are not designed for sea water use.

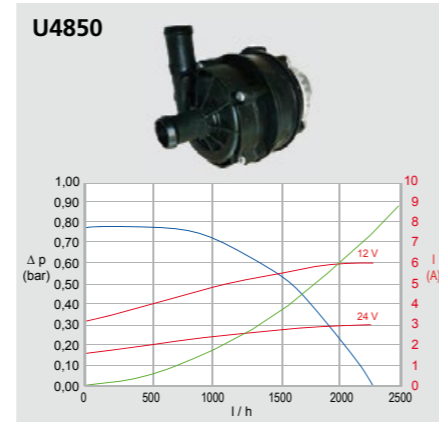
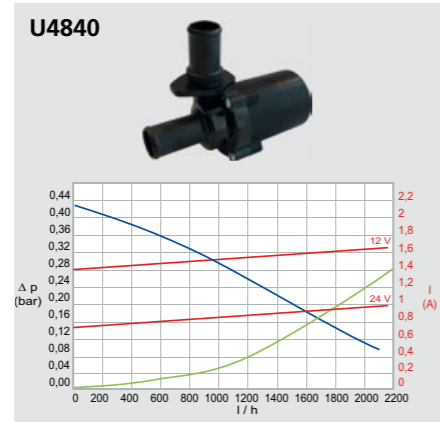
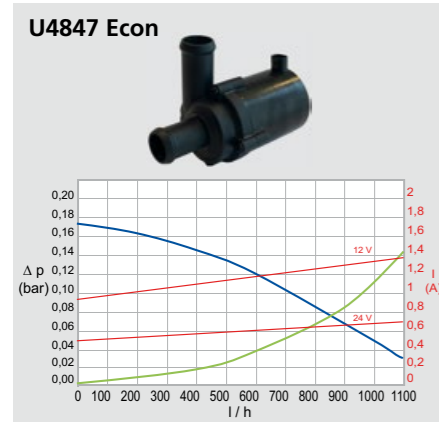

Volume flow with water/glycol mixture (50:50) 20°C

Flow resistance when the pump is stationary

Rated power consumption

Coolant Pumps





Technical data

Model overview (Heater and Pumps)	Thermo Top Evo 4/5/5+, Thermo Pro 50 Eco	Thermo Pro 90	Thermo Top Pro 120/150
	U4847 Econ	U4840	U4850
Nominal voltage (V)	12/24		
Nominal power consumption (W)	15	29	67
Volume flow (l/h)	500 (0.14 bar)	700 (0.34 bar)	1,500 (0.56 bar)
Dimensions L x W x H (mm)	109 x 49 x 79	134 x 53 x 90	118 x 80 x 104
Water connection, Ø (mm)	20		
Weight (kg)	0.3	0.4	0.7
Order number 12 V	9002514B 130° connection piece	1321930A	Included SOD Thermo Top Pro 120/150
Order number 24 V	98237B	1321932A	Included SOD Thermo Top Pro 120/150





Control Elements

Wireless		Air Top 2000 STC	Air Top Evo 40/55	Thermo Top Evo	Thermo Pro 50 Eco	Thermo Pro 90	Thermo Top Pro 120/150	Order number
	ThermoConnect TCon2							
	<ul style="list-style-type: none"> - 12/24 V - Available control functions: heating, ventilation, setting of timers, heating time management (HTM) - Individual operating time between 1 minute – 24 hours and continuous heating - Multiple vehicle control with one app possible, 2G and 4G based control unit with integrated antenna - Including push button with integrated temperature sensor and operation indicator - App available for Android, iOS and Web App my.webasto-connect.com for every web connected device - Alexa skill myWebasto available for Alexa capable devices 	■	■	■	■	■	■	9040223E
	Remote control Telestart T100 HTM							
	<ul style="list-style-type: none"> - 12 V - Including 1 hand-held transmitter with battery, receiver, self-adhesive window antenna - ESV adapter and temperature sensor HTM - Automatic heating time calculation 			■	■	■		1314637A
	Hand-held transmitter T100 HTM							
	Incl. battery			■	■	■		1314638B
	Remote control Telestart T99							
	<ul style="list-style-type: none"> - 12 V - Available control functions: heating, ventilation - Individual operating time between 10 – 120 minutes and continuous heating - Incl. one handheld transmitter with battery, receiver, self-adhesive window antenna and wiring harness 			■	■	■	9039217A	
	Hand-held transmitter T99							
	<ul style="list-style-type: none"> - Incl. battery, Included in kit 9039217A - Up to four transmitters can be connected 			■	■	■	9039224A	
	Y-adapter for parallel installation of an additional control							
	For connecting a second control element	■	■	■	■	■	■	1319820A

Control Elements

Wired		Air Top 2000 STC	Air Top Evo 40/55	Thermo Top Evo	Thermo Pro 50 Eco	Thermo Pro 90	Thermo Top Pro 120/150	Order number
	UniControl							
	<ul style="list-style-type: none"> - 12/24 V - Available control functions: heating, ventilation, one activatable timer (3 preselectable on-times per day, programmable for 7 days in advance), quick start button - Individual operating time between 10 – 120 minutes and continuous heating - Quick and intuitive operation thanks to a large TFT display and multifunction button, Instrument lighting (terminal 58) - Ignition plus (terminal 15, for ad hoc continuous heating) - ADR - Cover panel dimensions (L x W): 88.6 x 41.3 mm, installation depth: 30.6 mm - Including wiring harness adapter UniControl – 9034555A 	■	■	■	■	■	■	9034520C
	UniControl - replacement set standard timer 1531							
	<ul style="list-style-type: none"> - 12/24 V - Available control functions: heating, ventilation, one activatable timer (3 preselectable on-times per day, programmable for 7 days in advance), quick start button - Individual operating time between 10 – 120 minutes and continuous heating, Quick and intuitive operation thanks to a large TFT display and multifunction button - Instrument lighting (terminal 58), Ignition plus (terminal 15, for ad hoc continuous heating) - ADR - Cover panel dimensions (L x W): 88.6 x 41.3 mm, installation depth: 30.6 mm - Including adapter cable timer 1531 – 9034596A 	■	■	■	■	■	■	9034521C
	Adapter cable UniControl							
	<ul style="list-style-type: none"> - 10-pole (UniControl) to 4-pole standard plug - Cable length 0.13 m 	■	■	■	■	■	■	9034555A
	Adapter cable UniControl – replacement standard timer 1531							
	<ul style="list-style-type: none"> - 10-pole (UniControl) to 12-pole connector of preselection timer 1531 - Cable length 0.2 m 	■	■	■	■	■	■	9034596A
	Expansion kit UniControl							
	<ul style="list-style-type: none"> - Expansion cable for additional wiring (e.g. switching input, terminal 15) - 5 single wires with one-sided crimped flat connector, Flat connectors can be pinned into the still vacant slots of the 10-pole UniControl plug - Including 5 butt connectors - Cable length 3 m 	■	■	■	■	■	■	9034597A





Control Elements

	Air Top 2000 STC	Air Top Evo 40/55	Thermo Top Evo	Thermo Pro 50 Eco	Thermo Pro 90	Thermo Top Pro 120/150	Order number
 <p>Installation frame UniControl, short</p> <ul style="list-style-type: none"> - Cover panel dimensions (L x W): 120 x 60 mm - With installation materials 	■	■	■	■	■	■	474630
 <p>MultiControl Mar RV ATE</p> <ul style="list-style-type: none"> - 12/24 V - Available control functions: heating, ventilation - 21 activatable timer (3 preselectable on-times per day, programmable for 7 days in advance), quick start button, - Additional adapter cable harness ventilation for Evo heaters - Individual operating time between 10 – 120 minutes and continuous heating - Quick and intuitive operation thanks to a large TFT display and multifunction button - Cover panel dimensions (L x W) 68 x 48 mm, installation depth: 15 mm - Including adhesive pad - Pre-set to Air Top 2000 STC, all other air heaters can be selected 	■	■					9030910E
 <p>MultiControl Mar RV TT</p> <ul style="list-style-type: none"> - 12/24 V - Available control functions: heating, ventilation - 21 activatable timer (3 preselectable on-times per day, programmable for 7 days in advance), quick start button - Individual operating time between 10 – 120 minutes and continuous heating - Quick and intuitive operation thanks to a large TFT display and multifunction button - Cover panel dimensions (L x W) 68 x 48 mm, installation depth: 15 mm - Including adhesive pad - Pre-set to Thermo Top Evo, all other water heaters can be selected 			■	■	■	■	9030911D
 <p>Holding frame Multi-/SmartControl</p> <ul style="list-style-type: none"> - Fastened by screws at the mounting point - Multi-/SmartControl is clicked into the holding frame 	■	■	■	■	■	■	9030077A

Switches

 <p>Rotary selector switch</p> <ul style="list-style-type: none"> - 12/24 V - Available control functions: steplessly adjustable heating - With operation indicator and fault display by blink code - Cover panel dimensions: Ø 49 mm, installation depth 55 mm 	■	■					1322581A
---	---	---	--	--	--	--	----------

Control Elements

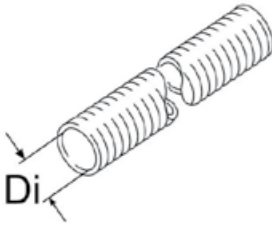
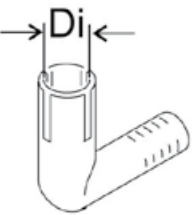
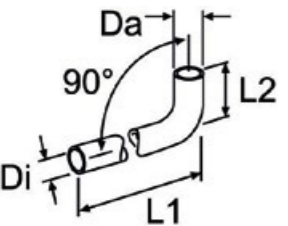
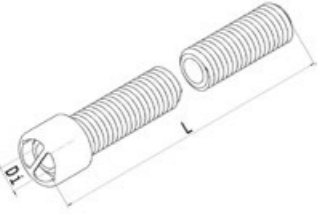
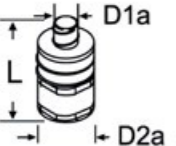

	Air Top 2000 STC	Air Top Evo 40/55	Thermo Top Evo	Thermo Pro 50 Eco	Thermo Pro 90	Thermo Top Pro 120/150	Order number
 <p>Control panel without ventilation switch</p> <ul style="list-style-type: none"> - For rotary selector switch (1322581A) - Cover panel dimensions (L x W): 84 x 41.6 mm 	■	■					1319733A
 <p>Control panel with ventilation switch</p> <ul style="list-style-type: none"> - For rotary selector switch (1322581A) - Cover panel dimensions (L x W): 84 x 41.6 mm - For heating and ventilation 	■	■					92240A
 <p>Rocker switch ON/OFF</p> <ul style="list-style-type: none"> - 12/24 V - Available functions: ON/OFF-switch - LED to indicate heater operation - Cover panel dimensions (L x W): 23 x 23 mm (drilling hole 20 mm) 			■	■	■		9032550A
 <p>Adapter cable ventilation</p> <p>Additional adapter cable harness ventilation for Evo heaters</p>							1320829A

Combustion Air Line

		Air Top 2000 STC	Air Top Evo 40/55	Thermo Top Evo	Thermo Pro 50 Eco	Thermo Pro 90	Order number
	Flexible pipe						
	PAK						
	Di = 22, L = 20,000	■	■	■			1321565A
	Di = 25, L = 5,000		■				1321587A
	Di = 30, L = 5,000				■		1321557A
	Combustion air elbow						
	Plastic						
	Di = 22	■	■	■			1320144A
	Di = 25		■				1320278A
	Combustion air hose						
	Di = 22, Da = 27, L1 = 1,000, L2 = 80, black	■	■	■			1320842A
	Air intake silencer						
	Di = 22, L = 800, PAK, without protection cap	■	■	■			1322455A
	Di = 25, L = 650, PAK, with protection cap		■				1319924A
	Di = 30, L = 1,160, PAK, without protection cap				■		1319607A
	Air intake silencer						
	D1a = 24.2, D2a = 52, L = 138, complete with 300 mm flexible pipe, plastic		■				9025956A

Please refer to our separate heating product catalog for our full range of accessories.

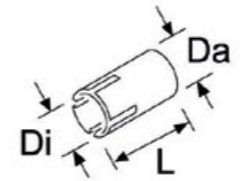
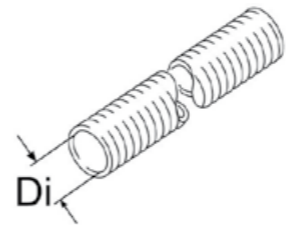

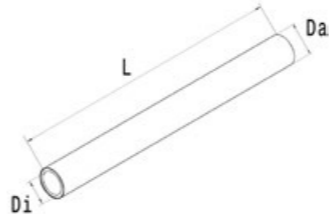
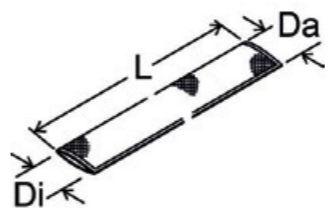
Exhaust System

		Air Top 2000 STC	Air Top Evo 40/55	Thermo Top Evo	Thermo Pro 50 Eco	Thermo Pro 90	Thermo Top Pro 120/150	Order number
	Exhaust pipe extension							
	Di = 22, Da = 24, L = 40, stainless steel	■	■	■				1320382A
	Flexible pipe							
	Stainless steel							
	Di = 22, Da = 26, L = 1,000, with end cap	■	■	■				1322414A
	Di = 24, Da = 28, L = 1,000		■					1321523A
	Di = 38, Da = 41, L = 5,000				■	■		1321540A
	Di = 38, Da = 41, L = 10,000				■	■		1321541A
	Di = 38, Da = 41, L = 20,000				■	■		1321539A
	Protective pad							
	Insulation blanket for silencer					■		9028104A
	Heat protection hose							
	Fiberglass, with cover, non-flammable, interior resistant to temperatures up to 500°C							
	Di = 28, Da = 38, L = 324	■	■	■	■			1319670A
	Di = 45, Da = 55, L = 1,000					■	■	1328352A
	Flexible heat protection hose							
	Di = 70, Da = 120, fiberglass							
	L = 1,250					■	■	9016230B
	L = 1,700					■	■	9016231B
	L = 1,850					■	■	1320830A

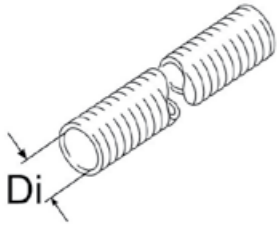
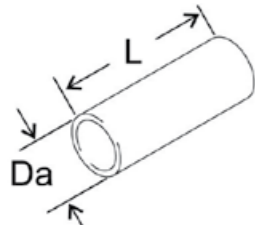
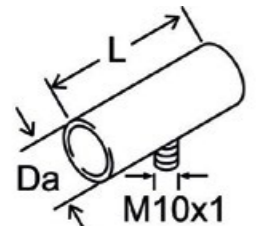
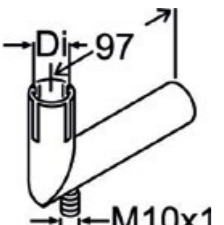
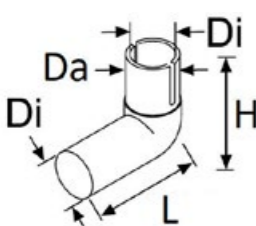
Exhaust System

	Air Top 2000 STC	Air Top Evo 40/55	Thermo Top Evo	Thermo Pro 50 Eco	Thermo Pro 90	Thermo Top Pro 120/150	Order number	
	Flexible heat protection hose							
	L = 10,000							
	Di = 28, GA-A	■	■	■	■			1321601A
	Di = 45, GA2-A				■	■		1321602C
	Exhaust connecting pipe							
	Da = 24, L = 50, stainless steel	■						1319937A
	Exhaust connecting pipe							
	L = 65, stainless steel							
	Da = 24	■						1319935A
	Da = 38, with condensate drain			■	■			1320959A
	Exhaust elbow							
	Di = 24, Da = 24, L = 97, stainless steel							
	Without condensate drain	■						1320383A
	With condensate drain	■						1320378A
	Exhaust elbow							
	Without condensate drain							
	Di = 22, Da = 22, L = 65, H = 46, aluminium	■	■	■				1320117A
	Di = 38, Da = 38, L = 131, H = 100, stainless steel				■	■		1328762A

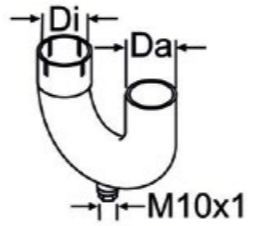
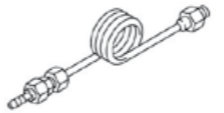
Exhaust System

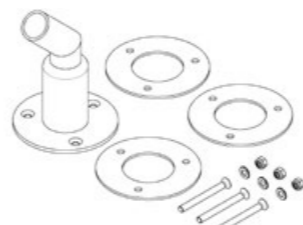
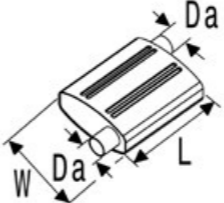

	Air Top 2000 STC	Air Top Evo 40/55	Thermo Top Evo	Thermo Pro 50 Eco	Thermo Pro 90	Thermo Top Pro 120/150	Order number		
	Exhaust elbow								
	Di = 38, Da = 38, 180°, with condensate drain, stainless steel							■	1319380A
	Condensate drain								
	L = 128, M10x1, with mounting parts, copper							■	92621A
	Exhaust lead through								
	Double walled, bended, stainless steel								
	Da = 24	■						1320364A	
	Da = 38			■	■			1320365A	
	Exhaust lead through								
	Double walled, straight, stainless steel								
	Da = 24	■						1320363A	
	Da = 38			■	■			1320983A	
	Exhaust silencer								
	Di = 24.5, Da = 56, L = 1,800, L1 = 650, L2 = 850							■	1322001A
	Di = 38, L = 1,000, outside with partial fiberglass insulation							■	1321823A

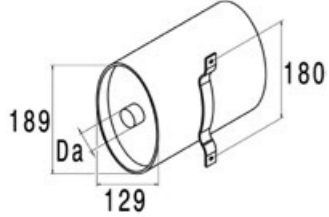
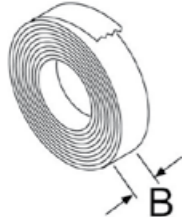
Exhaust System

	Air Top 2000 STC	Air Top Evo 40/55	Thermo Top Evo	Thermo Pro 50 Eco	Thermo Pro 90	Thermo Top Pro 120/150	Order number
 <p>Exhaust silencer Da = 38, L = 270, stainless steel</p>						<input checked="" type="checkbox"/>	1321397A
 <p>Insulating tape L = 50,000, W = 60, white, fibre glass, temperature up to 450°C, 2 mm thick</p>	<input checked="" type="checkbox"/>	<input checked="" type="checkbox"/>	<input checked="" type="checkbox"/>	<input checked="" type="checkbox"/>	<input checked="" type="checkbox"/>	<input checked="" type="checkbox"/>	1320357A

Please refer to our separate heating product catalog for our full range of accessories.

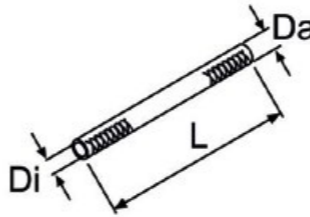
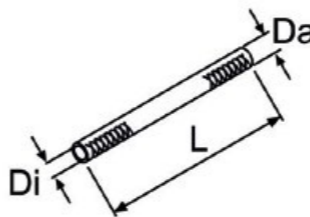
Fuel System

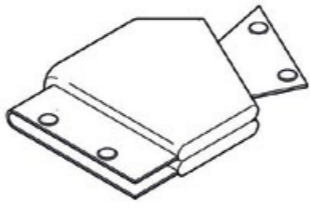
	Air Top 2000 STC	Air Top Evo 40/55	Thermo Top Evo	Thermo Pro 50 Eco	Thermo Pro 90	Thermo Top Pro 120/150	Order number
 <p>Connecting hose Di = 5, Da = 12, L = 50, rubber</p>	<input checked="" type="checkbox"/>	<input checked="" type="checkbox"/>	<input checked="" type="checkbox"/>	<input checked="" type="checkbox"/>	<input checked="" type="checkbox"/>	<input checked="" type="checkbox"/>	1320857A
 <p>Fuel hose kit ISO7840, USCG Di = 3.5, ISO7840, USCG, black</p>							
L = 1,000	<input checked="" type="checkbox"/>	<input checked="" type="checkbox"/>	<input checked="" type="checkbox"/>	<input checked="" type="checkbox"/>	<input checked="" type="checkbox"/>	<input checked="" type="checkbox"/>	3317180A
L = 3,300	<input checked="" type="checkbox"/>	<input checked="" type="checkbox"/>	<input checked="" type="checkbox"/>	<input checked="" type="checkbox"/>	<input checked="" type="checkbox"/>	<input checked="" type="checkbox"/>	3317046A
L = 6,000	<input checked="" type="checkbox"/>	<input checked="" type="checkbox"/>	<input checked="" type="checkbox"/>	<input checked="" type="checkbox"/>	<input checked="" type="checkbox"/>	<input checked="" type="checkbox"/>	3317047A
L = 10,000	<input checked="" type="checkbox"/>	<input checked="" type="checkbox"/>	<input checked="" type="checkbox"/>	<input checked="" type="checkbox"/>	<input checked="" type="checkbox"/>	<input checked="" type="checkbox"/>	3317048A
 <p>Flexible heat protection hose Di = 14.5, Da = 16.5, GA-A</p>							
L = 5,000	<input checked="" type="checkbox"/>	<input checked="" type="checkbox"/>	<input checked="" type="checkbox"/>	<input checked="" type="checkbox"/>	<input checked="" type="checkbox"/>	<input checked="" type="checkbox"/>	1321585B
L = 20,000	<input checked="" type="checkbox"/>	<input checked="" type="checkbox"/>	<input checked="" type="checkbox"/>	<input checked="" type="checkbox"/>	<input checked="" type="checkbox"/>	<input checked="" type="checkbox"/>	1321584B
 <p>Fuel line kit Da = 5, L = 5,000 Di = 1.5, stainless steel</p>	<input checked="" type="checkbox"/>	<input checked="" type="checkbox"/>	<input checked="" type="checkbox"/>	<input checked="" type="checkbox"/>	<input checked="" type="checkbox"/>	<input checked="" type="checkbox"/>	1320860A
Fuel line kit with connecting hoses, screws and clips, stainless steel	<input checked="" type="checkbox"/>	<input checked="" type="checkbox"/>	<input checked="" type="checkbox"/>	<input checked="" type="checkbox"/>	<input checked="" type="checkbox"/>	<input checked="" type="checkbox"/>	66958B
 <p>Mini jacket fuel pump protector Protection device for fuel pumps with mufflers, required by ISO 7840 if the fuel system is installed in engine rooms</p>	<input checked="" type="checkbox"/>	<input checked="" type="checkbox"/>	<input checked="" type="checkbox"/>	<input checked="" type="checkbox"/>	<input checked="" type="checkbox"/>	<input checked="" type="checkbox"/>	1319522A

Fuel System

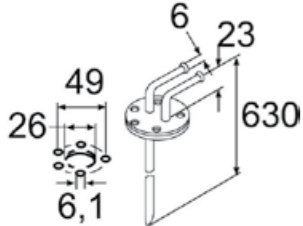
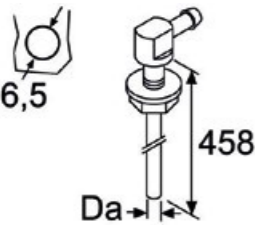
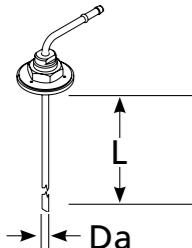
	Air Top 2000 STC	Air Top Evo 40/55	Thermo Top Evo	Thermo Pro 50 Eco	Thermo Pro 90	Thermo Top Pro 120/150	Order number
 <p>Tank extracting device, riser pipe Da = 6, L = 630, steel, zinc coated, with return, 90° extractor connection piece, for installation in metal tanks</p>						■	1322830D
 <p>Tank extracting device Da = 5, 90°, clamps and fuel hose pieces</p>	■	■	■	■	■		1322632A
 <p>Tank extracting device, riser pipe</p> <p>Di = 2.6, Da = 5, L = 650, steel, zinc coated, 90° extractor connection piece, for installation in metal tanks</p> <p>Di = 6, Da = 8, L = 500, steel, zinc coated, 90° extractor connection piece, for installation in metal tanks</p>	■	■	■	■		■	1320399A 1319372A

Fuel System

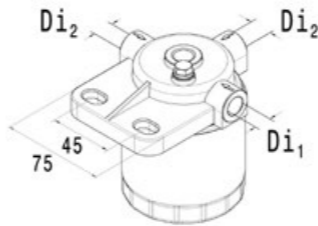
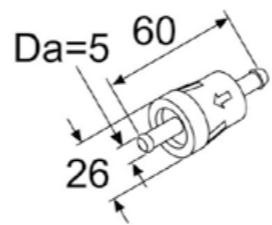
	Air Top 2000 STC	Air Top Evo 40/55	Thermo Top Evo	Thermo Pro 50 Eco	Thermo Pro 90	Thermo Top Pro 120/150	Order number
 <p>Fuel filter Da = 76, H = 108, filter holder with interchangeable filter, KC 20</p>						■	9036520A
 <p>Fuel filter kit Da = 5, L = 60, with hose clips and connecting hoses, plastic, transparent</p>	■	■	■	■	■		1319466A

Please refer to our separate heating product catalog for our full range of accessories.

Hot Air System

Advantages and Features

Webasto offers a wide range of components for air distribution with high flexibility to fit any application.

The advantages:

- Full range of mounting parts needed for any application
- Multiple combination possibilities to suit any application
- Coloured air outlets, black, white, grey and brown fitting to any interior
- Fast and easy installation, also in small spaces
- High temperature resistance from -40°C up to +140°C with PA6.6 GF30 glass fibre reinforced synthetic material

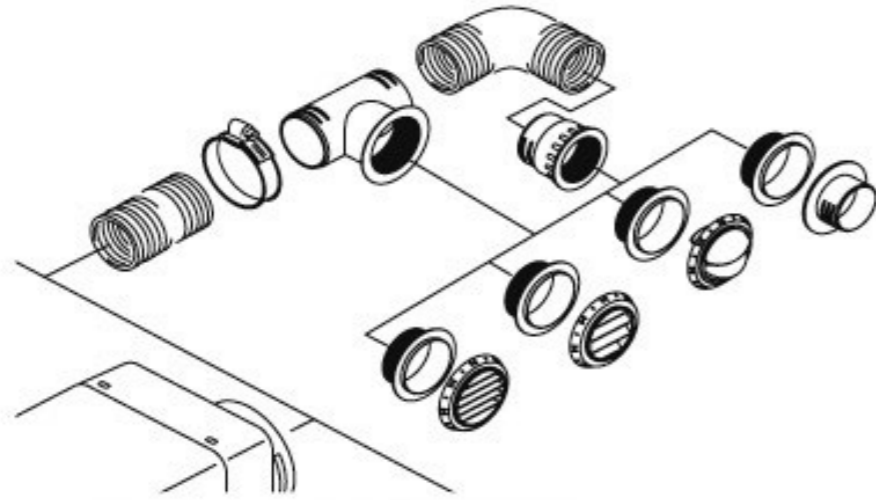

Webasto is not liable for applications made with non-Webasto air ducting parts, especially for parts not guaranteeing high temperature resistance.

Hot Air System

Air Flow Resistance Calculation

To ensure correct application with the correct air distribution system, it is important to have a continuous main line with openings that cannot be closed. The sum of the resistance points of the main line must not exceed the maximum number of resistance points for each air heater model. Lines branching off from the main line are not taken into account.

Consequently, the branches can also be designed with closable outlets. In the following table, several air ducting parts are listed. Exceeding the number of points (excessive air resistance of the heating air system) is detected by the heater after starting. For safety reasons, continuous heating operation is then no longer possible and the heater switches to control pause.

		Air Top 2000 STC: max. 325 resistance points			Air Top Evo 40: max. 550 resistance points Air Top Evo 55: max. 375 resistance points		
		55 / 60 mm inlet			80 / 90 mm inlet		
		Dim. in mm	Points	Id.	Dim. in mm	Points	Id.
Intake grill / grille		60	24	1320163A	90	65	1310581A
Flexible tubing per meter		55	30	various	80	27	various
		60	27	various	90	25	various
Additional points for elbow in flexible tube		55	10	various	80	7	various
		60	8	various	90	6	various
Air ducting silencer		-	-	-	90	24	1321734A
		-	-	-	90	16	1320996A
Reducing adapter air intake					90 > 80	45	1320186A
Reducing adapter		60 > 55	27	1320127A	80 > 55	223	1319477A
		-	-	-	80 > 60	172	1319312A
		-	-	-	90 > 60	211	1320760A
		-	-	-	90 > 80	45	1320185A
		-	-	-	90 > 80	45	1320925A
Hose connector		55	12	1319473A	80	5	1319476A
		60	10	1320469A	90	5	1319869A

Hot Air System

Air Flow Resistance Calculation

			Air Top 2000 STC: max. 325 resistance points			Air Top Evo 40: max. 550 resistance points Air Top Evo 55: max. 375 resistance points		
			55/60 mm inlet			80/90 mm inlet		
			Dim. in mm	Points	Id.	Dim. in mm	Points	Id.
Elbow for air outlet			-	-	-	60	35	1320124A
Elbow			-	-	-	80	50	1319272A
			-	-	-	90	77	1320706A
Branch			55/55/55	10	1321019A	80/55/80	8	1319479A
			60/60/60	9	1320472A	80/80/80	9	1319315A
			-	-	-	90/60/90	8	1320707A
			-	-	-	90/60/90	8	1321034A
Branch			55/55/55	22	1321019A	80/55/80	230	1319479A
			60/60/60	21	1320472A	80/80/80	50	1319315A
			-	-	-	90/60/90	228	1320707A
			-	-	-	90/60/90	228	1321034A
Y-piece			60/60/60	20	1320814A	80/55/55	230	1320753A
			-	-	-	80/60/60	201	1320471A
			-	-	-	80/80/80	50	1320375A
			-	-	-	90/90/90	42	1320470A
T-piece			60/60/60	13	1320474A	90/90/90	13	1320473A
T-piece			60/60/60	63	1320474A	90/90/90	61	1320473A
Distributor with control valve			55/55/55	19	1319224A	80/80/80	21	1319214A
			60/60/60	20	1320352A	90/90/90	21	1320926A
Distributor Y-piece			55/55/55	21	1319416A	80/80/80	50	1319212A

Hot Air System

Air Flow Resistance Calculation

			Air Top 2000 STC: max. 325 resistance points			Air Top Evo 40: max. 550 resistance points Air Top Evo 55: max. 375 resistance points		
			55/60 mm inlet			80/90 mm inlet		
			Dim. in mm	Points	Id.	Dim. in mm	Points	Id.
Threaded T-piece			60/60/60	8	1320476A	90/60/90	11	1320475A
Threaded T-piece			60/60/60	36	1320476A	90/60/90	254	1320475A
Rotatable air outlet			Ø 60/black	24	1322405A	-	-	-
Closeable air outlet			Ø 55/black	64	1320812A	-	-	-
			Ø 60/ black	59	1320206A	-	-	-
			Ø 60/white	59	1320207A	Ø 90/white	50	1320713A
			Ø 60/grey	59	1320937A	Ø 90/black	50	1320355A
			Ø 60/brown	59	1320208A	Ø 90/grey	50	1320714A
Outlet 45°			Ø 55/45°/black	142	107836	Ø 80/45°/black	136	107984
			Ø 60/45°/black	139	1320204A	Ø 90/45°/black/pivoted	134	1320956A
			Ø 60/45°/white	139	1320205A	Ø 90/45°/black	134	1320709A
			Ø 60/45°/grey	139	1320933A	Ø 90/45°/white	134	1320710A
			Ø 60/45°/brown	139	1320761A	Ø 90/45°/grey	134	1320354A
			Ø 60/45°/white	139	1320205A	Ø 90/45°/black	134	1320709A
Outlet 90°			Ø 55/90°/black	37	101625	-	-	-
			Ø 60/90°/black	35	1320934A	Ø 80/90°/black	35	1322710A
			Ø 60/90°/white	35	1320935A	Ø 90/90°/black	33	1320932A
			Ø 60/90°/grey	35	1320936A	Ø 90/90°/grey	33	1320712A
			Ø 60/90°/brown	35	1320762A	Ø 90/90°/white	33	1320711A
			Ø 60/90°/white	35	1320205A	Ø 90/45°/black	134	1320709A
Wall socket			55	10	1319417A	80	11	1319471A
			55	10	1320063A	90	12	1320924A
			60	10	1320923A	-	-	-
Wall socket with air outlet			60	24	1322634A	-	-	-
Air intake grille			60	139	1319269A	80	137	1319269A
			-	-	-	90	134	1319269A

Air ducting combination possibilities:

Air ducting: At least flex pipe & air outlet, all other parts optional.

Air intake: At least air intake grille, all other parts optional

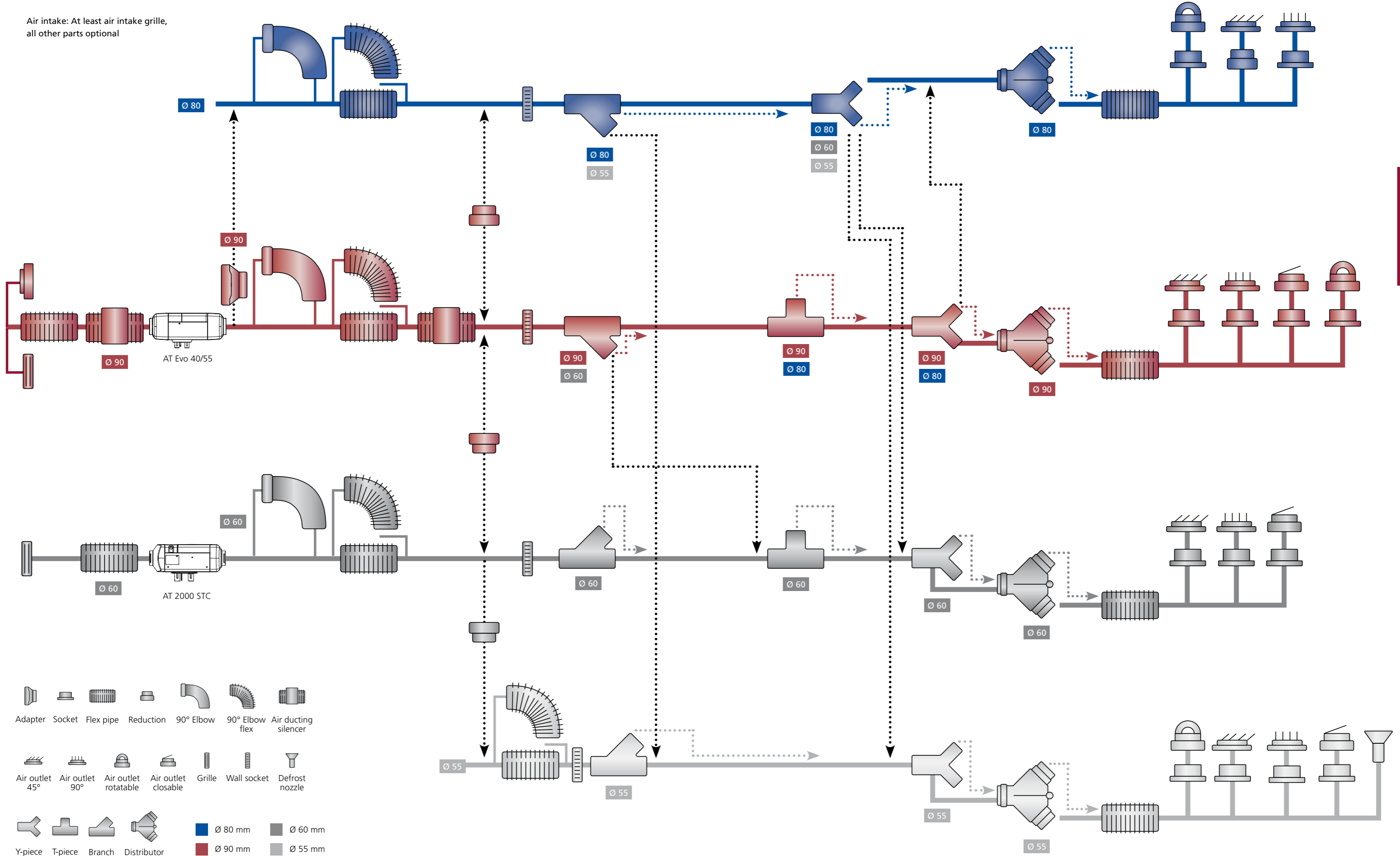

Hot Air System

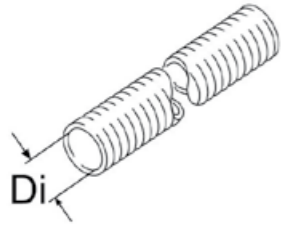
	Air Top 2000 STC	Air Top Evo 40/55	Order number
	Flexible pipe, 55 mm, suitable only with adapter		
	Di = 55		
	■	■	L = 2,000, APK, black 1315889A
	■	■	L = 2,000, PAPK, grey 1321580B
	■	■	L = 10,000, APK, black 1322082A
	■	■	L = 10,000, PAK 1321701B
	■	■	L = 25,000, APK, black 1311891C
	■	■	L = 25,000, PAPK, grey 1311896C
	Flexible pipe, 60 mm, suitable for Air Top 2000 STC, for other heaters with adapter		
	Di = 60		
	■	■	L = 2,000, APK, black 1321574B
	■	■	L = 2,000, PAPK, grey 1321504A
	■	■	L = 5,000, APK, black 1321575C
	■	■	L = 10,000, APK, black 1322083C
	■	■	L = 10,000, PAK, black 1321692B
	■	■	L = 10,000, PAPK, grey 1321727C
	■	■	L = 20,000, PAK, black 1321697B
	■	■	L = 25,000, APK, black 1311892C
■	■	L = 25,000, PAPK, grey 1311898C	

Hot Air System

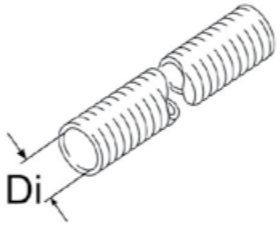
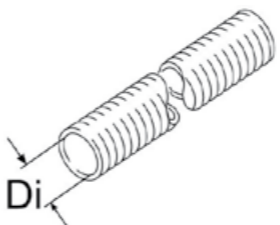
	Air Top 2000 STC	Air Top Evo 40/55	Order number
	Flexible pipe, 80 mm, suitable only with adapter		
	Di = 80		
	■	■	L = 1,000, AA, grey 1321531A
	■	■	L = 2,000, APK, black 1321576C
	■	■	L = 2,000, PAPK, grey 1321582B
	■	■	L = 5,000, APK, black 1321577B
	■	■	L = 10,000, AA, grey 1321533A
	■	■	L = 10,000, APK, black 1321718C
	■	■	L = 10,000, PAK 1322147B
	■	■	L = 10,000, PAPK, grey 1321729B
	■	■	L = 25,000, APK, black 1311893C
	■	■	L = 25,000, PAPK, grey 1311900C
	Flexible pipe, 90 mm, suitable for Air Top Evo 40/55, for other heaters with adapter		
	Di = 90		
	■	■	L = 2,000, APK, black 1321578C
	■	■	L = 2,000, PAPK, grey 1321506B
	■	■	L = 5,000, APK, black 1321579C
	■	■	L = 5,000, PAPK, grey 1321508A
	■	■	L = 10,000, APK, black 1321719C
	■	■	L = 10,000, PAPK, grey 1321731C
	■	■	L = 25,000, APK, black 1311894C
	■	■	L = 25,000, PAPK, grey 1311902C

Hose Specification

APK: Aluminium, Paper, Plastic – black, with white Webasto logo



PAK: Paper, Aluminium, Plastic – black, with white Webasto logo

PAPK: Paper, Aluminium, Paper, Plastic – grey, with red and blue Webasto logo, extra strong 4 layer design

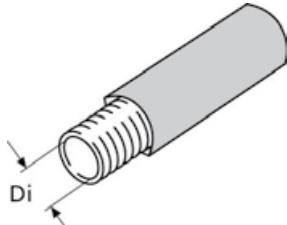
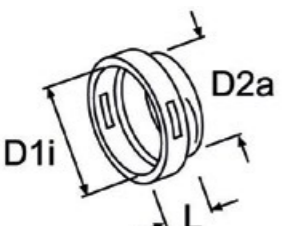
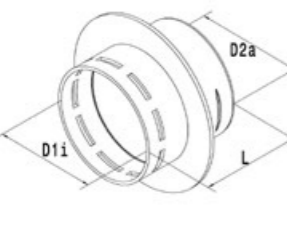
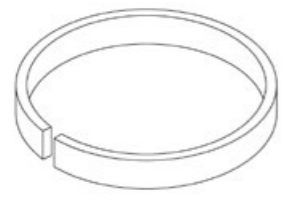
Hot Air System

	Air Top 2000 STC	Air Top Evo 40/55	Order number
 <p>Elbow Di = 80.5, Da = 79, L = 115, steel, corrosion-resistant, 90°</p>	■	■	1319272A
 <p>Insulated hose L = 12,000, PAK Di = 80 Di = 90</p>	■	■	1321515A 1321517A
 <p>Adapter for heater connection D1i = 90, D2a = 80, L = 40, plastic</p>	■	■	1320186A
 <p>Adapter for heater connection D1i = 60, D2a = 75, L = 40, plastic</p>	■	■	1321005A
 <p>Adapter ring Di = 55, Da = 60, aluminium Di = 70, Da = 80, W = 17, plastic, for outlet 1319946A, black</p>	■	■	1320224A 1320040A

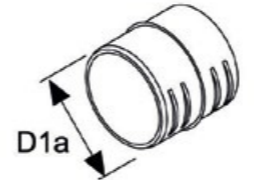
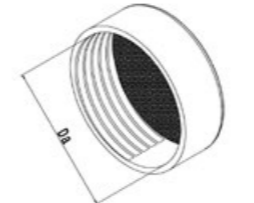
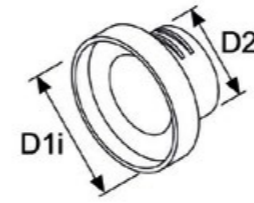
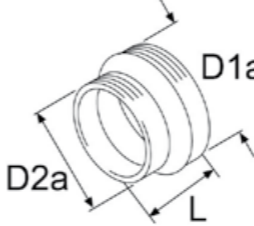
Hot Air System

	Air Top 2000 STC	Air Top Evo 40/55	Order number
 <p>Double fitting Plastic, black D1a = 55, L = 55, for connecting flexible pipes D1a = 60, L = 51, for connecting flexible pipes D1a = 80, L = 75, for connecting flexible pipes D1a = 90, L = 51, for connecting flexible pipes</p>	■	■	1319473A 1320469A 1319476A 1319869A
 <p>End cap Plastic, black Da = 60 Da = 90</p>	■	■	1320477A 1319870A
 <p>Extension adapter D1i = 90, for connecting flexible pipes, in connection with union nut 1320468A, plastic, black D2a = 60, L = 59 D2a = 80, L = 50</p>	■	■	1320760A 1320925A
 <p>Reduction adapter For connecting flexible pipes D1a = 60, D2a = 55, L = 35, plastic, black D1a = 80, D2a = 55, L = 82, plastic, black D1a = 80, D2a = 60, L = 190, steel, corrosion-resistant D1a = 90, D2a = 80, L = 45, plastic, black</p>	■	■	1320127A 1319477A 1319312A 1320185A
 <p>Elbow Da = 90, plastic, black</p>	■	■	1320706A



Hot Air System

	Air Top 2000 STC	Air Top Evo 40/55	Order number
			
Hot air elbow 90° for heater connection			
Di = 60, Da = 60, plastic, black	■	■	1320124A
Wall feed-through			
plastic, black			
D1a = 85, D2a = 55	■	■	1319417A
D1a = 90, D2a = 60	■	■	1320923A
D1a = 120, D2a = 90	■	■	1320924A
Adapter wall socket			
L = 72.5, plastic, black			
D1a = 90, D2a = 55	■	■	1320063A
D1a = 110, D2a = 80, can be combined with wall feed-through	■	■	1319471A
Union nut			
L = 60, plastic, black			
D1a = 60, in combination with 60 mm air outlet	■	■	1320922A
D1a = 90, in combination with 90 mm air outlet	■	■	1320468A
Junction fitting			
45°			
D1a = 55, D2a = 55, L = 137, plastic, black	■	■	1321019A
D1a = 60, D2a = 60, L = 145, plastic, black	■	■	1320472A
D1a = 80, D2a = 55, L = 151, plastic, black	■	■	1319479A
D1a = 80, D2a = 80, L = 186, plastic, black	■	■	1319478A
D1a = 80, D2a = 80, L = 370, steel, corrosion-resistant	■	■	1319315A
D1a = 90, D2a = 60, L = 146, plastic, black	■	■	1320707A
D1a = 90, D2a = 60, L = 185, plastic, black	■	■	1321034A

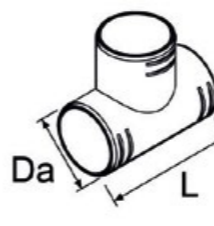
Hot Air System

	Air Top 2000 STC	Air Top Evo 40/55	Order number
			
T-piece			
L = 110, plastic, black			
Da = 60	■	■	1320474A
Da = 90	■	■	1320473A
T-piece			
Di = 60, black			
Da = 60, L = 100, plastic, in combination with 60 mm air outlet, with thread	■	■	1320476A
Da = 90, L = 140, plastic, in combination with 60 mm air outlet, with thread	■	■	1320475A
Distributor Y-unit			
Plastic, black			
Da = 55, with remote control flap valve	■	■	1319224A
Da = 60	■	■	1320352A
Da = 80, with remote control flap valve	■	■	1319214A
Da = 90	■	■	1320926A
Distributor Y-unit			
Plastic, black			
Da = 55	■	■	1319416A
Da = 80	■	■	1319212A
Distributor Y-unit			
Plastic, black			
Da = 60	■	■	1320814A
Da = 90	■	■	1320470A

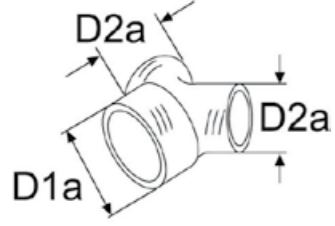
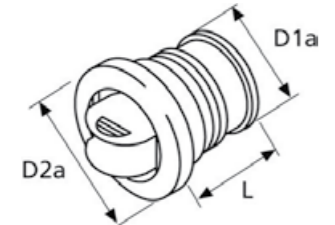
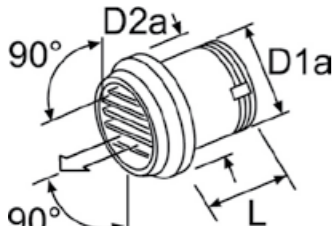

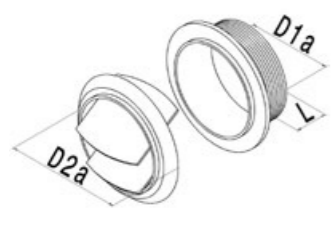
Hot Air System

	Air Top 2000 STC	Air Top Evo 40/55	Order number
	Air outlet 45° rotatable		
	Plastic, black		
	■	■	1320753A
	■	■	1320471A
	■	■	1320375A
	Air outlet		
	D2a = 100, L = 63, black, plastic, lockable, with wall feed through, use for secondary flow only		
	■	■	1320812A
	■	■	1319946A
	Air outlet		
	L = 65, plastic, insert grid, straight, rotating, 90°, black		
	■	■	101625
	■	■	1322710A
	Air outlet		
	Plastic, through flow with bushing, 45°		
	■	■	1320204A
	■	■	1320205A
	■	■	1320761A
	■	■	1320933A
	■	■	1320354A
	■	■	1320709A
■	■	1320710A	
	Air outlet		
	Lockable, with wall feed through		
	■	■	1320206A
	■	■	1320207A
	■	■	1320208A
	■	■	1320937A
	■	■	1320355A
■	■	1320713A	
	■	■	1320714A

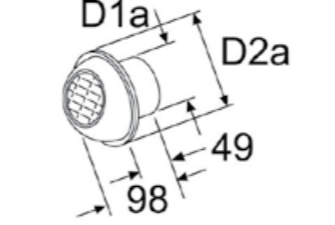
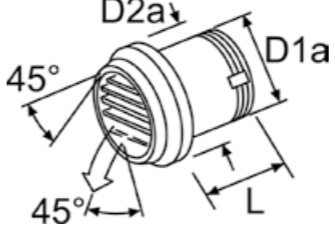
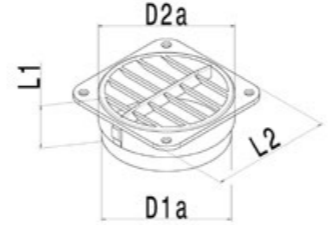
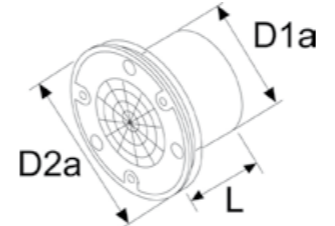

Hot Air System

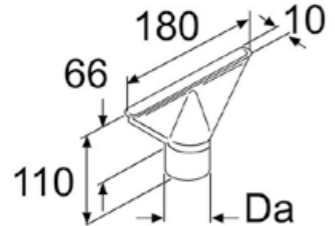
	Air Top 2000 STC	Air Top Evo 40/55	Order number
	Air outlet		
	Plastic, 90°, with wall feed through		
	■	■	1320934A
	■	■	1320935A
	■	■	1320936A
	■	■	1320711A
	■	■	1320712A
	■	■	1320762A
	■	■	1320932A
	Air outlet		
	■	■	1322405A
	Air outlet		
	L = 65, plastic, rotatable, black		
	■	■	107836
	■	■	107984
	Air outlet		
	■	■	1320956A
	Air outlet		
	■	■	1322634A

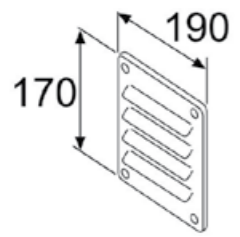
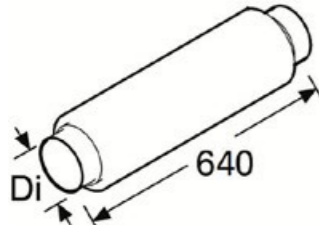
Hot Air System

	Air Top 2000 STC	Air Top Evo 40/55	Order number
			
Demist nozzle			
Da = 55, steel, corrosion-resistant	■	■	1319470A
Protective screen			
For intake and outlet openings of heater, plastic, black			
Di = 60	■		1320163A
Di = 90		■	1310581A
			
Protective screen			
Di = 60, for flex tube intake, rubber	■		1320173A
			
Louvre plate			
L = 190, H = 170, aluminium, for air intake only	■	■	1319269A
			
Air ducting silencer			
Di = 90, L = 640, aluminium/plastic	■	■	1321734A
			

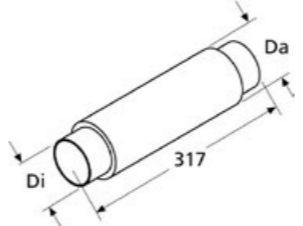
Hot Air System

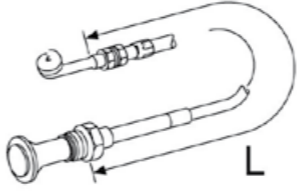
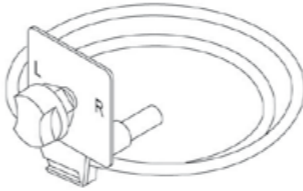
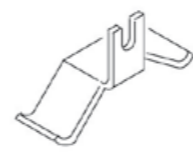
	Air Top 2000 STC	Air Top Evo 40/55	Order number
			
Air ducting silencer			
Di = 90, Da = 122, L = 317, plastic, black	■	■	1320996A
Console			
10 pieces	■	■	1321044A
			
Control cable			
With grip and outer sleeve, for Y-pieces			
L = 850	■	■	1320785A
L = 1,500	■	■	1320786A
			
Control device for distributor			
L = 2,000, for Y-pieces, with control butterfly valve	■	■	1319868A
			
Clamp			
For bowden cable 1320785A and 1320786A	■	■	1319688A
			

Blower Heat Exchangers

The blower modules are the ideal combination for Webasto water heaters. Thanks to their powerful blowers, the cabins of boats and yachts can be heated up quickly. Most models have an adjustable blower speed to fine-tune the air flow according to individual needs. In addition to their compact dimensions they ensure an easy installation.

The Product Range



Florida 3 – extra-silent single speed 3 kW model with very low power consumption



Florida 5 – Compact 3-speed 5 kW model with blower speed and heat output regulation



Florida 5 – Compact 3-speed 5 kW model without controls

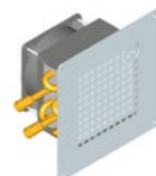

Whisperer – Very compact and silent 1,8 kW model with single speed axial fan



Madeira 4 – Lightweight and variable 4 kW model, 3 blower speeds, choice of air outlet



Madeira 8 – Lightweight and variable 7,3 kW model, 3 blower speeds, choice of air outlet



BB4 – Compact 2,5 kW model with 3-speed blower regulation and metal casing



BB8 – Powerful 8 kW model with 3-speed blower regulation and robust metal casing

Blower Speed Control

The blower speed control is the perfect match for all blower heat exchangers. It provides temperature regulated automatic blower speed control or manual 5-speed blower regulation. With a variable temperature setting, everybody can find his perfect comfort climate.



Scopes of delivery

- Control element
- Electronic PWM module
- Temperature sensor (5 meters)

Blower speed control – temperature-regulated blower speed control for the blower modules Florida 5 without controls, BB4, BB8. With separate mounting also possible for Madeira 4 and Madeira 8.

Model	Order number	Colour	Voltage (V)	Heat output at Q100 (kW)	Air flow at free discharge (m ³ /h)	Water connection diam. (mm)	Electrical power consumption (W)	Dimensions W x H x D (mm)	Weight (kg)
Florida 3 No Noise	3200740A	light grey	12	3	120	16	12	269 x 198 x 141	1.4
	3200741A	light grey	24	3	120	16	12	269 x 198 x 141	1.4
Florida 5 with controls	3200679A	light grey	12	5.2	285	16	120	269 x 198 x 218	2
	3200680A	light grey	24	5.2	285	16	120	269 x 198 x 218	2
Florida 5 without controls	3200681A	light grey	12	5.2	285	16	120	269 x 198 x 218	2
	3200682A	light grey	24	5.2	285	16	120	269 x 198 x 218	2
Whisperer	3200673A	Inox (front)	12	1.8	120	16	8.4	210 x 210 x 125	1.2
	3200674A	Inox (front)	24	1.8	120	16	8.4	210 x 210 x 125	1.2
BB4	71174000	blue	12	2.5	190	16	38	310 x 150 x 150	3.5
	71174500	blue	24	2.5	190	16	38	310 x 150 x 150	3.5
BB8	3395977A	blue	12	8	525	16	65	480 x 170 x 305	12
	3395978A	blue	24	8	525	16	65	480 x 170 x 305	12
Madeira 4	71174550	light grey and dark grey	12	4.6	200	16	70	275 x 115 x 203	1.8
	71174552	light grey and dark grey	24	4.6	200	16	70	275 x 115 x 203	1.8
Madeira 8	71174554	light grey and dark grey	12	7.3	300	16	150	376 x 115 x 250	3.1
	71174556	light grey and dark grey	24	7.3	300	16	150	376 x 115 x 250	3.1
Outlet versions									
Air grille 90 x 90 mm*	3396524A	black							
Air hose connector diam. 55 mm*	3396525A	black							
* When ordering the Madeira 4 or Madeira 8, please specify the type and amount of desired air outlets. Madeira 4 requires 2 and Madeira 8 requires 4 outlets.									
Control elements									
Blower speed control	3391288C		12/24					123 x 80 x 40	0.4
* Please refer to pictures of Madeira 4 and Madeira 8 for example of air grille and hose connectors, see previous page.									

Water System

Accessories: Water System



Webasto offers a wide range of high-quality Hep₂O products.

- Cabling ability – Hep₂O provides faster, safer and more cost effective installation
- Less jointing – Hep₂O flexible polybutylene pipe system requires less jointing, thus saves time and materials
- Joint security – the Hep₂O push-fit piping offers reliable jointing and safe assembly
- High resistance to impact and vibration – solder free, and the Hep₂O system is extremely strong and resistant to denting and accidental damage from impact or vibration
- Corrosion free – Hep₂O completely eliminates electrolytic corrosion and is highly resistant against aggressive salt-water and other corrosive media

For the complete overview of Hep₂O parts please refer to the water system section for BlueCool accessories in this catalog.



Water System

	eThermo Top Eco 20 P/30 P	Thermo Top Evo	Thermo Pro 50 Eco	Thermo Pro 90	Thermo Top Pro 120/150	Order number
	Hose					
	EPDM, black					
	Di = 15, Da = 22, L = 2,400					1320300A
	Di = 18, Da = 27, L = 2,000					1319379A
	Di = 20, Da = 27, L = 380					1320960A
	Molded hose 90°					
	Black					
	Di = 15, Da = 22, L1 = 1,020, L2 = 50, 90°					1320789A
	Di = 18, Da = 25, L1 = 136, L2 = 92, 90°					1320907A
	Di = 18, Da = 25, L1 = 500, L2 = 47, 90°					1319953A
	Di = 18, Da = 25, L1 = 1,020, L2 = 50, 90°					1320794A
	Di = 20, Da = 27, L1 = 70, L2 = 70, 90°					1319839A
	Di = 20, Da = 27, L1 = 130, L2 = 48, 90°					1320147A
	Di = 20, Da = 27, L1 = 360, L2 = 20, 90°					1320961A
	Di = 20, Da = 27, L1 = 615, L2 = 56, 90°					1320197A
	Molded hose 90°					
	Di = 18, Da = 25, 90°					1319418A
	Molded hose 180°					
	180°, black					
	Di = 18, Da = 25, L1 = 18, L2 = 18, r = 25 mm					1319401A
	Di = 20, Da = 27, L1 = 40, L2 = 64, r = 24 mm					1319623A
	Molded hose 180°					
	L2 = 20, H = 75, 180°					
	Di = 15, Da = 22, L1 = 580					1320790A
	Di = 18, Da = 25, L1 = 580					1319421A
	Di = 18, Da = 25, L1 = 1,100					1322496A

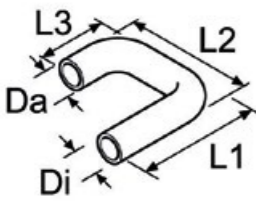
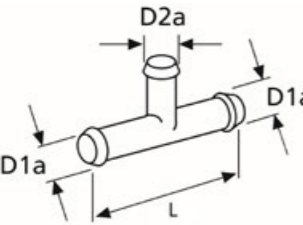
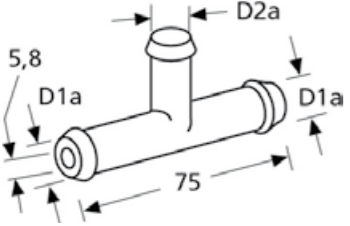
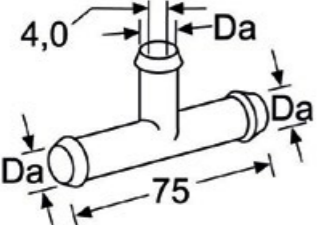
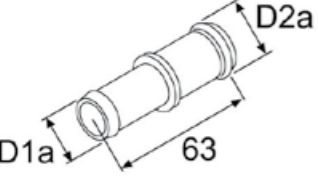
Water System

	eThermo Top Eco 20 P/30 P	Thermo Top Evo	Thermo Pro 50 Eco	Thermo Pro 90	Thermo Top Pro 120/150	Order number	
	Molded hose 180°						
	180°, black						
	Di = 18, Da = 25, L1 = 110, L2 = 20, H = 54	■	■	■	■	■	1322493A
Di = 20, L1 = 190, L2 = 113	■	■	■	■	■	1322473A	
	T-piece						
	D1a = 15, D2a = 15, L = 75, steel, corrosion-resistant	■	■	■	■	■	1319289A
	D1a = 18, D2a = 15, L = 75, steel, corrosion-resistant	■	■	■	■	■	1320532A
	D1a = 18, D2a = 18, L = 75, plastic, black	■	■	■	■	■	1321001A
	D1a = 20, D2a = 10, L = 75, steel, corrosion-resistant	■	■	■	■	■	1319846A
	D1a = 20, D2a = 15, L = 75, steel, corrosion-resistant	■	■	■	■	■	1319290A
	D1a = 20, D2a = 20, L = 75, plastic, black	■	■	■	■	■	1327590A
	D1a = 20, D2a = 25, L = 100, aluminium				■	■	1328140B
	T-piece						
	D1a = 20, D2a = 20, L = 75, brass, with restrictor, restrictor diameter 5.8 mm	■	■	■	■	■	1319817A
	T-piece						
	Da = 18, L = 75, brass, with restrictor, restrictor diameter 4 mm	■	■	■	■	■	1319800A
	Connecting pipe						
	L = 63, black						
	D1a = 15, D2a = 20, plastic, 10 pieces	■	■	■	■	■	1321000A
	D1a = 17, D2a = 20, plastic	■	■	■	■	■	1320143A
	D1a = 18, D2a = 18, plastic, 10 pieces	■	■	■	■	■	9006211A
	D1a = 18, D2a = 20, plastic, 10 pieces	■	■	■	■	■	9005819C
	D1a = 18, D2a = 22, plastic	■	■	■	■	■	1320155A
	D1a = 20, D2a = 20, plastic	■	■	■	■	■	1320342A
	D1a = 20, D2a = 22, plastic	■	■	■	■	■	1319594A

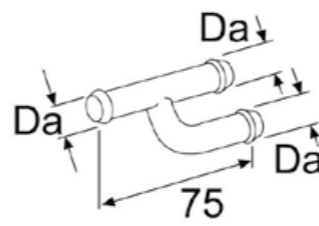

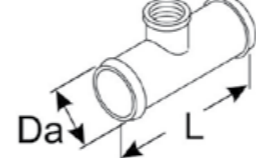
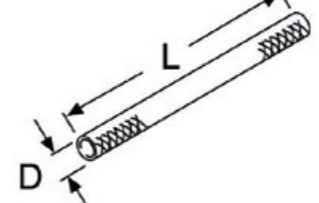
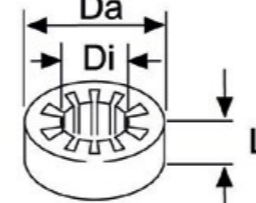
Water System

	eThermo Top Eco 20 P/30 P	Thermo Top Evo	Thermo Pro 50 Eco	Thermo Pro 90	Thermo Top Pro 120/150	Order number
	Connecting pipe, y-type					
	Da = 18, L = 75, steel, corrosion-resistant	■	■	■	■	■
	Connecting pipe					
	Di = 15, L = 75, brass	■	■	■	■	■
	Connecting pipe with thread					
	Da = 18, L = 100, M22x1.5, steel, corrosion-resistant, for thermostat	■	■	■	■	■
	Braided protection hose					
	Di = 24, L = 1,500, polyester, chafing guard for water hoses 22 – 35 mm	■	■	■	■	■
	Rubber ring (anti-chafing device)					
	L = 20, not permitted for exhaust systems, elastomer					
	Di = 20.5, Da = 40	■	■	■	■	■
Di = 25.5, Da = 45	■	■	■	■	■	1312780A

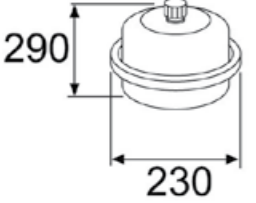
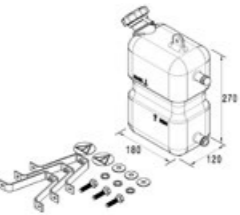
Water System

	eThermo Top Eco 20 P/30 P	Thermo Top Evo	Thermo Pro 50 Eco	Thermo Pro 90	Thermo Top Pro 120/150	Order number
						
Pressure expansion tank 8 l, prepressure 0.5 bar, red	■	■	■	■	■	1320545A
						
Header tank vertical L = 180, W = 120, H = 270, 5 liter, net content 3 liter, vertical, made of polypropylene for high temperature resistance, tank kit includes 3 stainless steel mounting brackets	■	■	■	■	■	9024038A

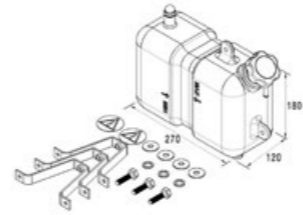
Water System

	eThermo Top Eco 20 P/30 P	Thermo Top Evo	Thermo Pro 50 Eco	Thermo Pro 90	Thermo Top Pro 120/150	Order number
						
Header tank horizontal L = 270, W = 120, H = 180, 5 liter, net content 3 liter, horizontal, made of polypropylene for high temperature resistance, tank kit includes 3 stainless steel mounting brackets	■	■	■	■	■	9024039A
						
Header tank 10 liter, 230 x 230 x 330	■	■	■	■	■	79289500

Please refer to our separate heating product catalog for our full range of accessories.

Valve

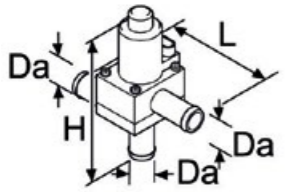
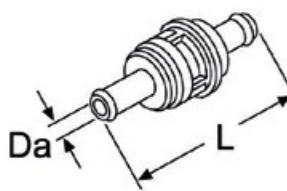
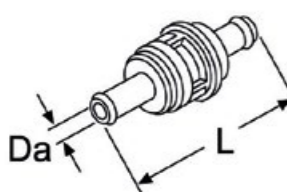
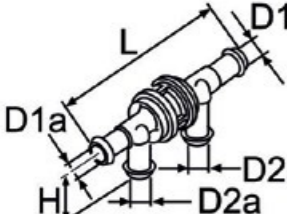
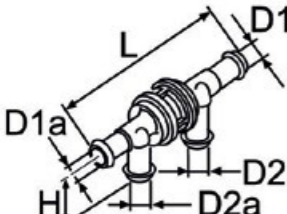
	eThermo Top Eco 20 P/30 P	Thermo Top Evo	Thermo Pro 50 Eco	Thermo Pro 90	Thermo Top Pro 120/150	Order number
 <p>Electric valve 3/2 way Da = 18, L = 84, W = 55, H = 101, V = 12, metal/plastic, 3/2-way, normally open</p>	■	■	■	■	■	9014606A
 <p>Check valve Plastic, with leak hole, black</p>						
Da = 15, L = 104	■	■	■	■	■	1320239A
Da = 18, L = 90	■	■	■	■	■	1319250A
 <p>Check valve Plastic, without leak hole, black</p>						
Da = 15, L = 104	■	■	■	■	■	1320240A
Da = 18, L = 100	■	■	■	■	■	1319484A
Da = 20, L = 120	■	■	■	■	■	1319554A
 <p>Check valve H = 42, with leak hole, plastic, black</p>						
D1a = 18, D2a = 18, L = 146	■	■	■	■	■	1319486A
D1a = 20, D2a = 20, L = 162	■	■	■	■	■	1319595A
 <p>Check valve D1a = 18, D2a = 18, L = 146, H = 42, without leak hole, plastic, black</p>						
	■	■	■	■	■	1319485A

Valve

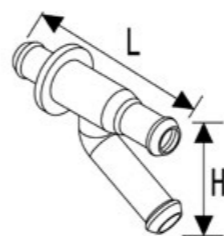
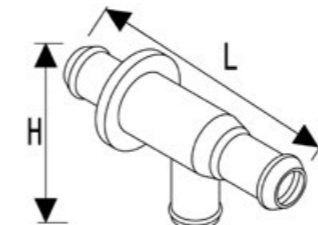
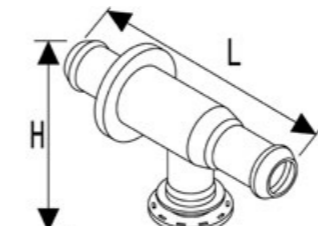
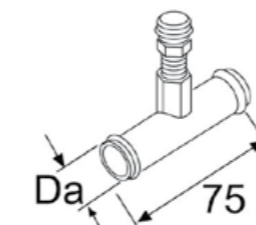

	eThermo Top Eco 20 P/30 P	Thermo Top Evo	Thermo Pro 50 Eco	Thermo Pro 90	Thermo Top Pro 120/150	Order number
 <p>Check valve L = 94</p>						
Da = 18, H = 42	■	■	■	■	■	1327550A
Da = 20, H = 43	■	■	■	■	■	1327551A
 <p>Check valve Da = 18, L = 94, H = 52, double check valve ball-type T</p>						
	■	■	■	■	■	1327549A
 <p>Check valve Da = 18, L = 94, H = 46, double check valve ball-type for heater connection</p>						
	■	■	■	■	■	9043408A
 <p>Bleeding valve L = 75, with bleeding valve, steel, corrosion-resistant</p>						
Da = 15	■	■	■	■	■	1319221A
Da = 18	■	■	■	■	■	1319219A
Da = 20	■	■	■	■	■	1320989A

Please refer to our separate heating product catalog for our full range of accessories.

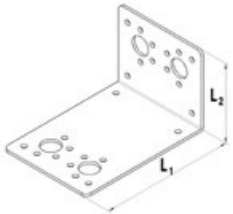
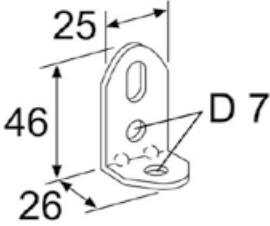
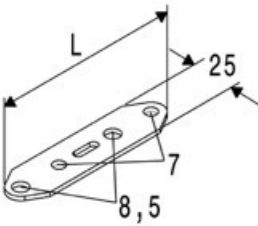
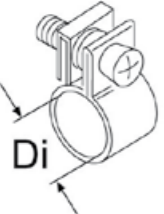
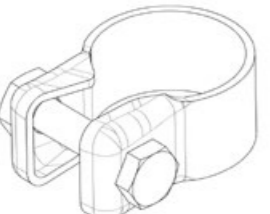
Mounting Parts

	Air Top 2000 STC	Air Top Evo 40/55	eThermo Top Eco 20 P/30 P	Thermo Top Evo	Thermo Pro 50 Eco	Thermo Pro 90	Thermo Top Pro 120/150	Order number
 <p>Heater bracket L1 = 157, L2 = 112, W = 130, stainless steel 3 mm, suitable for various installation options</p>	■	■						1319936A
 <p>Mounting bracket L = 46, W = 25 Stainless steel, 10 pieces Steel, zinc coated, 10 pieces</p>	■	■	■	■	■	■	■	1320264A 1320232A
 <p>Mounting strip L = 100, W = 25, steel, zinc coated, 10 pieces</p>	■	■	■	■	■	■	■	9007918A
 <p>Hose clip Steel, corrosion-resistant, bolt head with hexagon and cross-head slot Di = 8, 20 pieces Di = 9 Di = 12, 20 pieces Di = 14, 20 pieces</p>	■	■	■	■	■	■	■	1320244A 1320492A 1320246A 1320245A
 <p>Exhaust clamp W = 16, for flexible exhaust pipe, stainless steel Di 24 – 26 mm, with carriage bolt Di 26 – 28 mm, nut, welded</p>	■	■	■	■				1320165A 1320220A

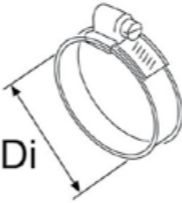
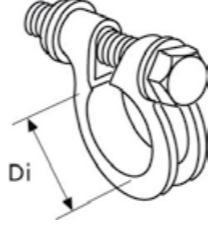
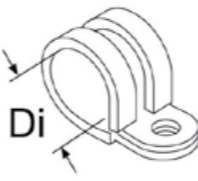
Mounting Parts

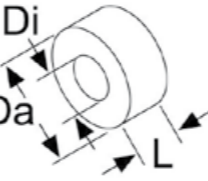
	Air Top 2000 STC	Air Top Evo 40/55	eThermo Top Eco 20 P/30 P	Thermo Top Evo	Thermo Pro 50 Eco	Thermo Pro 90	Thermo Top Pro 120/150	Order number
 <p>Hose clip W = 14.3, stainless steel Di 16 – 27 mm, 10 pieces Di 23 – 35 mm, 20 pieces Di 60 – 80 mm Di 80 – 100 mm, 10 pieces Di 90 – 110 mm</p>	■	■	■	■	■	■	■	9015918A 1320271A 9026066A 9043258A 1320085A
 <p>Pipe clamp W = 13.5, Di = 39 ... 42, steel, corrosion-resistant, with screw, for flexible exhaust pipe</p>						■	■	1320194A
 <p>Fastening clamp Di = 34, W = 20, chromed steel with rubber, 6.5 mm fastening hole, 10 pieces</p>	■	■	■	■	■	■	■	1320236A
 <p>Fastening clamp Di = 25, W = 15, chromed steel, 6.5 mm fastening hole, 10 pieces</p>	■	■	■	■	■	■	■	9023007A
 <p>Spacer bushing Di = 8, Da = 20, aluminium L = 5 L = 8 L = 10 L = 15 L = 20 L = 30 L = 40</p>	■	■	■	■	■	■	■	1320498A 1320499A 1320496A 1320090A 1320088A 1320089A 1319533A

Mounting Parts

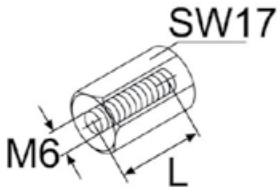
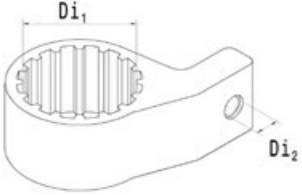
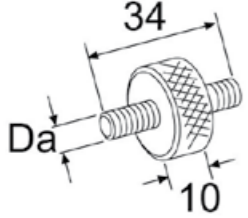
	Air Top 2000 STC	Air Top Evo 40/55	eThermo Top Eco 20 P/30 P	Thermo Top Evo	Thermo Pro 50 Eco	Thermo Pro 90	Thermo Top Pro 120/150	Order number
	Spacer nut							
	Steel, corrosion-resistant, SW = 17, M6							
	L = 20, 10 pieces							1320241A
	L = 30							1320083A
	L = 40							1319517A
	Fuel pump holder							
	D1i = 35, D2i = 6.5, rubber, 3 pieces, black							1320193A
	Anti-vibration mount							
	L = 34, M6, not suitable for fastening heaters, 5 pieces							9023020A

Please refer to our separate heating product catalog for our full range of accessories.

Electrical Accessories

	Air Top 2000 STC	Air Top Evo 40/55	Order number
	Temperature sensor RVM		
	L = 2,500		9037591A
	L = 5,000		9037593A
	L = 2,500, with plug		9030881A
	L = 5,000, with plug		9030883A

Please refer to our separate heating product catalog for our full range of accessories.

Maintenance and Diagnostics

Maintenance and Diagnostics

Heater Diagnosis Module

Webasto provides a complete set of diagnosis tools to service and repair its heaters. The diagnosis module includes a hardware unit and various connecting adaptors for each heater model. For more details and the latest diagnosis visit our dealer portal at: <http://dealers.webasto.com>

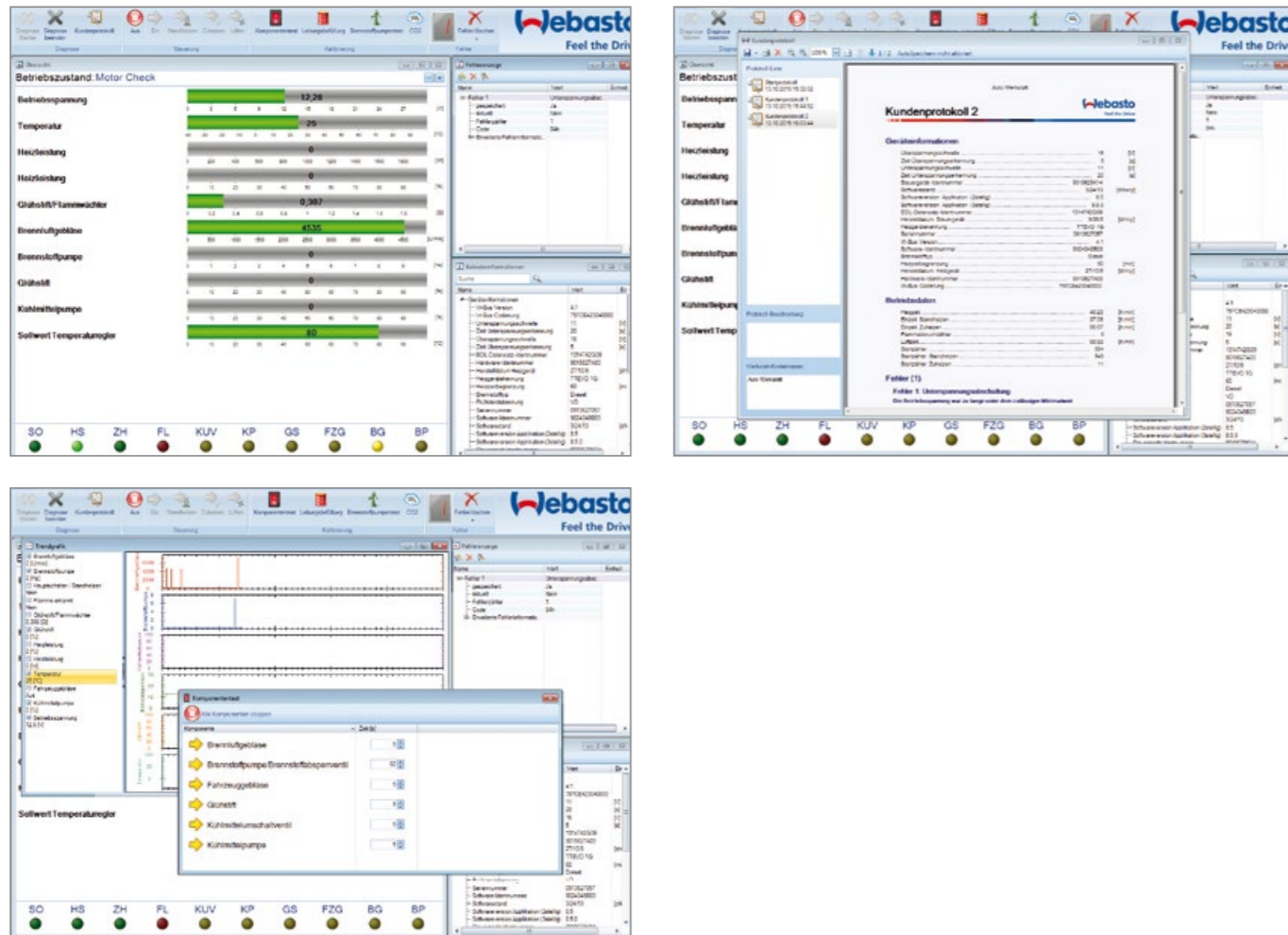

Screenshots from Webasto diagnosis software

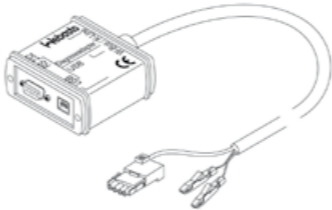
	Order number
	<p>PC diagnosis kit For Webasto heating devices, USB port, for Windows operating system</p> <p>1320920A</p>

Heating Accessories

Please refer to our separate heating product catalog for our full range of accessories.



Cooling Products

Which Is the Right Air-Conditioning System for Your Boat? 88

BlueCool Self-Contained Units 92

Product Overview 93

Application Concept 94

Application Guidelines 95

BlueCool S-Series 96

BlueCool Chiller Systems 98

Product Overview 99

Application Concept 100

Application Guidelines 101

BlueCool V-Series 102

BlueCool C-Series 104

BlueCool P-Series 106

BlueCool V-PRO Series 114

BlueCool Fresh Air Makeup Units

BlueCool F-Series 124

BlueCool Air Handlers

BlueCool A-Series 126

Which Is the Right Air-Conditioning System for Your Boat?



Our large product portfolio from compact air-conditioning systems up to large chiller systems leaves no wish unfulfilled. With our wide power range we provide cooling capacities from 6,000 BTU/h up to 1,000,000 BTU/h.

BlueCool Self-Contained Units



- Perfect solution for vessels with one to three cabins
- Very compact
- Easy to retrofit
- Extremely efficient

BlueCool Chiller Systems



- Large power range to fit any size of boat or superyacht
- Best in marine A/C: Ability to provide adequate cooling wherever it is needed
- Ideal basis for our integrated BlueComfort solutions

BlueCool Air Handlers



- Modular concept enables greatest possible flexibility
- Uses minimal space in cabins since air handlers are smaller than self-contained units
- Three construction forms: Compact, Slimline and Low Profile feature an especially compact, slim and flat design of the A-Series

How to Choose the Right Air-Conditioner

Example: You own a yacht and would like to aircondition a room of 5 m (length) x 5 m (width) x 2 m (height).

<p>Step 1: Define the category of the cabin</p> <p>Determine the category of the cabin. We give an example for a cabin with an average glass area, for example a deck saloon.</p>	Category 2
<p>Step 2: Define the net volume</p> <p>Determine the net volume of the room (5 m x 5 m x 2 m = 50 m³; subtract 20 % for furniture in the room; 50 m³ - 10 m³ = 40 m³; If you want to air condition the whole boat, please calculate the sum of your rooms.</p>	40 m ³
<p>Step 3: Define your climate region</p> <p>Determine the climate region where you spend most of your time. For example the Mediterrean Sea is a "normal region" in the climate category.</p>	Normal region
<p>Step 4: Identify your cooling requirements</p> <p>Result: You need an air conditioning system with a 20,000 BTU/h cooling capacity.</p>	20,000 BTU/h
<p>Step 5: Decide between a self-contained and chiller system</p> <p>Depending on the demands you can decide on a self-contained or chiller system with a cooling capacity of 20,000 BTU/h.</p>	BlueCool S20

Category 1			
portlights only, cabin(s) all below deck (400 BTU/m ³)			
Volume of the rooms L x W x H (m ³)	region: normal	cold	hot
10	4,000	3,000	5,000
20	8,000	6,000	10,000
30	12,000	9,000	15,000
40	16,000	12,000	20,000
50	20,000	15,000	25,000
60	24,000	18,000	30,000
70	28,000	21,000	35,000
80	32,000	24,000	40,000
90	36,000	27,000	45,000
100	40,000	30,000	50,000
110	44,000	33,000	55,000
120	48,000	36,000	60,000
130	52,000	39,000	65,000
140	56,000	42,000	70,000
150	60,000	45,000	75,000
160	64,000	48,000	80,000
170	68,000	51,000	85,000
180	72,000	54,000	90,000
190	76,000	57,000	95,000
200	80,000	60,000	100,000

For precise BTU calculations, please use our Marine specification and calculation tool, available on the dealer portal at <http://dealers.webasto.com>

The Right Cooling Capacity

Volume of the rooms L x W x H (m ³)	Category 1			Volume of the rooms L x W x H (m ³)	Category 2		
	region: normal	cold	hot		region: normal	cold	hot
10	4,000	3,000	5,000	10	5,000	3,750	6,250
20	8,000	6,000	10,000	20	10,000	7,500	12,500
30	12,000	9,000	15,000	30	15,000	11,250	18,750
40	16,000	12,000	20,000	40	20,000	15,000	25,000
50	20,000	15,000	25,000	50	25,000	18,750	31,250
60	24,000	18,000	30,000	60	30,000	22,500	37,500
70	28,000	21,000	35,000	70	35,000	26,250	43,750
80	32,000	24,000	40,000	80	40,000	30,000	50,000
90	36,000	27,000	45,000	90	45,000	33,750	56,250
100	40,000	30,000	50,000	100	50,000	37,500	62,500
110	44,000	33,000	55,000	110	55,000	41,250	68,750
120	48,000	36,000	60,000	120	60,000	45,000	75,000
130	52,000	39,000	65,000	130	65,000	48,750	81,250
140	56,000	42,000	70,000	140	70,000	52,500	87,500
150	60,000	45,000	75,000	150	75,000	56,250	93,750
160	64,000	48,000	80,000	160	80,000	60,000	100,000
170	68,000	51,000	85,000	170	85,000	63,750	106,250
180	72,000	54,000	90,000	180	90,000	67,500	112,500
190	76,000	57,000	95,000	190	95,000	71,250	118,750
200	80,000	60,000	100,000	200	100,000	75,000	125,000

Volume of the rooms L x W x H (m ³)	Category 3			Volume of the rooms L x W x H (m ³)	Category 4		
	region: normal	cold	hot		region: normal	cold	hot
10	6,000	4,500	7,500	10	7,500	5,625	9,375
20	12,000	9,000	15,000	20	15,000	11,250	18,750
30	18,000	13,500	22,500	30	22,500	16,875	28,125
40	24,000	18,000	30,000	40	30,000	22,500	37,500
50	30,000	22,500	37,500	50	37,500	28,125	46,875
60	36,000	27,000	45,000	60	45,000	33,750	56,250
70	42,000	31,500	52,500	70	52,500	39,375	65,625
80	48,000	36,000	60,000	80	60,000	45,000	75,000
90	54,000	40,500	67,500	90	67,500	50,625	84,375
100	60,000	45,000	75,000	100	75,000	56,250	93,750
110	66,000	49,500	82,500	110	82,500	61,875	103,125
120	72,000	54,000	90,000	120	90,000	67,500	112,500
130	78,000	58,500	97,500	130	97,500	73,125	121,875
140	84,000	63,000	105,000	140	105,000	78,750	131,250
150	90,000	67,500	112,500	150	112,500	84,375	140,625
160	96,000	72,000	120,000	160	120,000	90,000	150,000
170	102,000	76,500	127,500	170	127,500	95,625	159,375
180	108,000	81,000	135,000	180	135,000	101,250	168,750
190	114,000	85,500	142,500	190	142,500	106,875	178,125
200	120,000	90,000	150,000	200	150,000	112,500	187,500

For extreme climatic conditions such as the Persian Gulf with sea-water temperatures of 32 °C and air temperatures of 40 °C, you have to add 25 to 30 % onto the calculated figure. On BlueCool P-Series units it is also recommended that the condenser is increased in size.

BlueCool Self-Contained Units

BlueCool S-Series

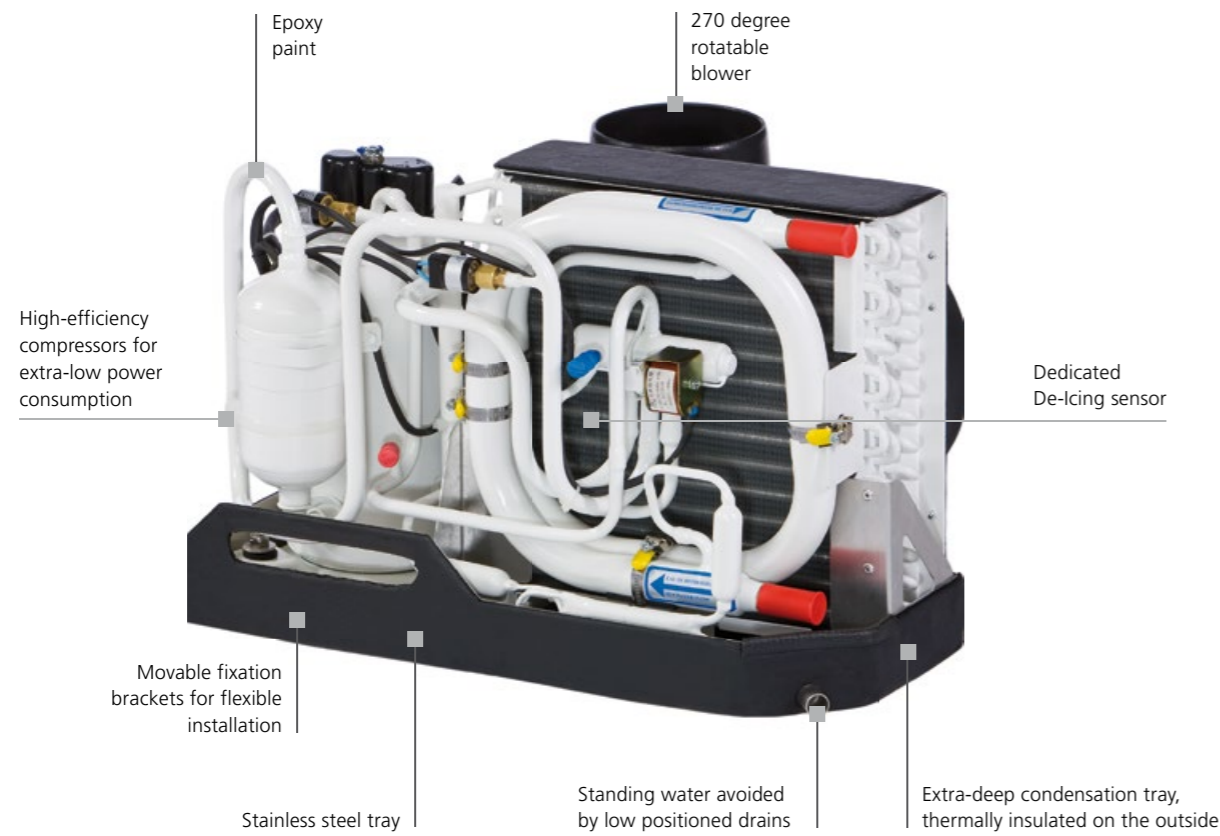

The BlueCool S-Series:

- Fully 50/60 Hz compatible (230 V)
- Suitable for worldwide usage
- Very high efficiency, using R410a refrigerant
- Continuous operation even under tropical conditions
- USB diagnosis for easy servicing and parameter setting
- Quiet operation
- Robust design
- Soft start devices available as an option
- Vibration absorber kits available as an option

BlueCool Self-Contained Units

Product Overview



BlueCool S-Series
S6 – S27 230 V

See page 96



BlueCool S-Series
S6 – S16 115 V

See page 97

S-Series comes with the new MyTouch display as a standard



BlueCool MyTouch

Self-contained air-conditioners:

- Stand alone unit
- Heating via reverse cycle integrated
- Extremely compact
- All components on one tray
- Lowest power consumption
- Including electronics, blower and controls
- Evaporator temperature control in real time mode

BlueCool Self-Contained Units

Application Concept

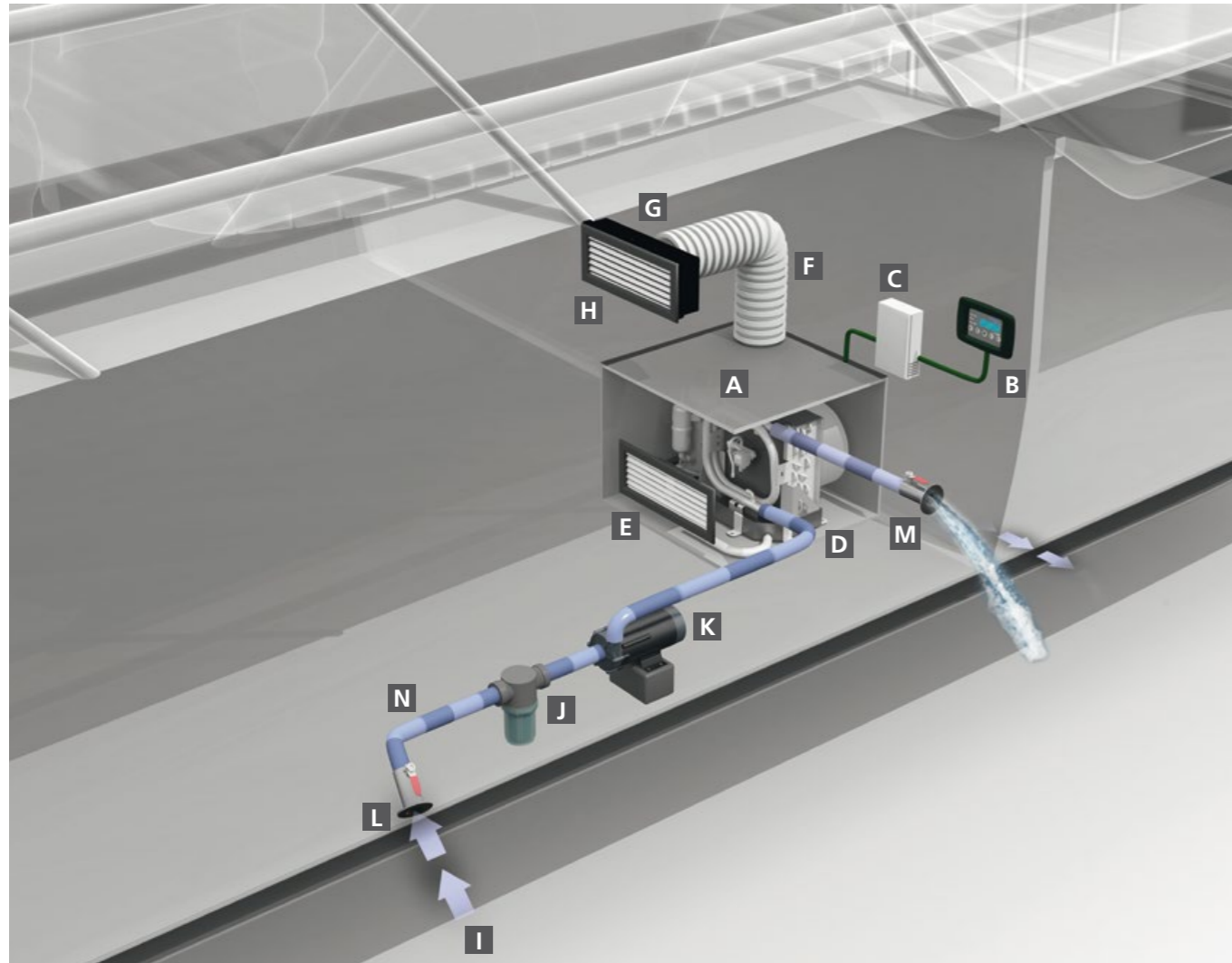

Installation of a BlueCool self-contained unit is quite simple:
 Each cabin has its own self-contained unit **A** providing cool air to this cabin. It is controlled by an air control unit **B** which is also located in this cabin.
 The generated heat is transferred into the sea via the sea water circuit **I** to **N**.

BlueCool Self-Contained Units

Webasto BlueCool self-contained air-conditioning units have one hermetically encapsulated compressor. The refrigerant circuit includes not only the compressor but also a condenser, a throttle element (capillary tube) as well as an evaporator. Self-contained units are extremely compact. All components (compressor, condenser, evaporator and blower) required for cooling a cabin, a salon, a lounge or another room are mounted on a stainless steel tray. Webasto self-contained units are available in different power ratings. This means you are sure to find the ideal system for the specific needs of almost all room sizes requiring cooling in a yacht.

BlueCool Self-Contained Units

Application Guidelines

For a complete self-contained unit, please select the following:

Core unit

Please select the core unit according to the required cooling capacity.

- | | | | |
|--------------------------------|-----------------------------|--------------------------|------------------------------|
| A Air-conditioning unit | See page 96 | B MyTouch display | See page 142 |
|--------------------------------|-----------------------------|--------------------------|------------------------------|

Position **A** and **B** as well as the following components are included in the scope of delivery:

- Electric cable and control box
- Installation manual
- Remote cabin temperature sensor 3 m
- Display cable 5 m
- Operating manual

Accessories

Please order separately the accessories for the application consisting of:

- | | | | |
|----------------------|------------------------------|-----------------------------|------------------------------|
| C Soft Starts | See page 160 | D Vibration absorber | See page 160 |
|----------------------|------------------------------|-----------------------------|------------------------------|

Air system

Please order separately the air ducting system for the application consisting of:

- | | | | |
|----------------------------|------------------------------|----------------------------|------------------------------|
| E Return air grille | See page 150 | F Air ducting | See page 151 |
| G Transition box | See page 151 | H Supply air grille | See page 150 |

Sea water circuit

Please order separately the components for the sea water circuit consisting of:

- | | | | |
|------------------------------|------------------------------|-----------------------------|------------------------------|
| I Sea water inlet | See page 158 | J Sea water strainer | See page 158 |
| K Sea water pump | See page 144 | L Closing valve | See page 158 |
| M Overboard discharge | See page 158 | N Water hose | See page 157 |

BlueCool S-Series

Self Contained Units

Technical data

Type	BlueCool S-Series 230 V						
	S6	S8	S10	S13	S16	S20	S27
Order numbers	WBCL120000B	WBCL120001E	WBCL120002E	WBCL120003E	WBCL120004F	WBCL120005E	WBCL120006F
Cooling capacity* (BTU/h)	6,000	8,000	10,000	13,000	16,000	20,000	27,000
Cooling capacity* (kW)	1.8	2.4	2.9	3.8	4.7	5.9	7.9
Heating via reverse cycle integrated	yes	yes	yes	yes	yes	yes	yes
Voltage (V)	230 (-15%/+10%)	230 (-15%/+10%)	230 (-15%/+10%)	230 (-15%/+10%)	230 (-15%/+10%)	230 (-15%/+10%)	230 (-15%/+10%)
Frequency (Hz)	50/60 (+-5%)	50/60 (+-5%)	50/60 (+-5%)	50/60 (+-5%)	50/60 (+-5%)	50/60 (+-5%)	50/60 (+-5%)
Current draw running** (A) 50 Hz	2 – 2,4	2.4 – 3.5	2.6 – 4.0	3.6 – 6.3	4.9 – 7.1	5.9 – 8.9	7.0 – 10.5
Current draw max. peak (A) 50 Hz	14	28	27	37	54	60	77
Current draw RMS40**** (A) 50 Hz	5	17	17	22	35	39	49
Current draw RMS300*** (A) 50 Hz	3	9	9	11	19	20	32
Current draw max. peak with Soft Start (A) 50 Hz	11	12	11	13	22	23	34
Current draw RMS40**** with Soft Start (A) 50 Hz	4	7	7	7	12	14	19
Current draw RMS300*** with Soft Start (A) 50 Hz	3	5	5	5	9	10	17
Locked Rotor Amperage LRA (A)	12	19	19	24	37	43	62
Max. circuit breaker (A)	16	16	16	16	16	16	20 (comp. only)
Air flow (free blowing) (m³/h)	275	275	400	500	625	625	2 x 550
Air flow (free blowing) (cfm)	162	162	235	294	368	368	2 x 324
Seawater connection (mm)	19	19	19	19	19	19	19
Seawater connection (inch)	3/4	3/4	3/4	3/4	3/4	3/4	3/4
Min. seawater flow at 50 Hz (l/min.)	6	8	10	12	14	17	21
Min. seawater flow at 60 Hz (l/min.)	7,5	10	12	14	17	20	25
Recommended seawater pump +	WB250	WB350	WB350	WB350/ WB500G	WB500/ WB500G	WB500/ WB500G	WB1000/ WB1000G
Dimensions L x W x H (mm)	405 x 320 x 305	405 x 320 x 305	480 x 335 x 315	510 x 350 x 325	550 x 350 x 370	595 x 340 x 370	575 x 515 x 410
Dimensions L x W x H (inch)	15.9 x 12.6 x 12.0	15.9 x 12.6 x 12.0	18.9 x 13.2 x 12.4	20.1 x 13.8 x 12.8	21.7 x 13.8 x 14.6	23.4 x 13.4 x 14.6	22.6 x 20.3 x 16.1
Blower connection (mm)	100	100	100	125	125	125	2 x 125
Blower connection (inch)	4	4	4	5	5	5	2 x 5
Weight (kg)	20	20	22	27	31	34	46

General note: Values in this table given for 50 Hz only. 60 Hz data available on request.

* BTU/h are based on 7°C evaporating temperature and 38°C condensing temperature

** Amperage values for core unit depend on compressor load. Max values at tropical conditions at 230 V/50 Hz

*** Starting amperage RMS (Root Mean Square) for core unit for first 300 ms

**** Starting amperage RMS (Root Mean Square) for core unit for first 40 ms

+ Recommendation only. Pump size shall be adapted to application constraints in order to always ensure minimal sea water flow.



Soft start device available as an option



BlueCool Expert, Display and Temperature Sensor access from outside

BlueCool S-Series



Technical data

Type	BlueCool S-Series 115 V				
	S6	S8	S10	S13	S16
Order No.	2510139B	2510140B	2510141B	2510142B	2510143B
Cooling capacity* (BTU/h)	6,000	8,000	10,000	13,000	16,000
Cooling capacity* (kW)	1.8	2.4	2.9	3.8	4.7
Heating via reverse cycle integrated	Yes	Yes	Yes	Yes	Yes
Voltage (V)	115 (-15%/+10%)	115 (-15%/+10%)	115 (-15%/+10%)	115 (-15%/+10%)	115 (-15%/+10%)
Frequency (Hz)	60 (+-5%)	60 (+-5%)	60 (+-5%)	60 (+-5%)	60 (+-5%)
Current draw running** (A) 60 Hz	3.6 – 5.5	4.5 – 6.1	5.6 – 7.9	7.6 – 11	8.0 – 15.7
Current draw max. peak (A) 60 Hz	39	54	55	70	89
Current draw RMS40**** (A) 60 Hz	25	35	36	47	59
Current draw RMS300*** (A) 60 Hz	19	20	21	30	35
Locked Rotor Amperage LRA (A)	27	34	37	57	70
Max. circuit breaker (A)	16	16	16	16	25 (compressor only)
Air flow (free blowing) (m³/h)	275	275	350	430	650
Air flow (free blowing) (cfm/h)	162	162	206	253	382
Seawater connection (mm)	19	19	19	19	19
Seawater connection (inch)	3/4	3/4	3/4	3/4	3/4
Minimal Seawater flow (l/min.) 60 Hz	6	8	10	12	14
Recommended seawater pump 60 Hz +	WB250	WB350	WB350	WB350 WB500G	WB500 WB500G
Dimensions L x W x H (mm)	405 x 320 x 300	405 x 320 x 305	480 x 335 x 315	510 x 345 x 325	550 x 340 x 370
Dimensions L x W x H (inch)	15.9 x 12.6 x 11.8	15.9 x 12.6 x 12.0	18.9 x 13.2 x 12.4	20.1 x 13.6 x 12.8	21.7 x 13.4 x 14.6
Blower connection (mm)	100	100	100	125	125
Blower connection (inch)	4	4	4	5	5
Weight (kg)	18	18	20	25	29

* BTU/h are based on 7°C evaporating temperature and 38°C condensing temperature

** values for core unit depend on compressor load. Max values at tropical conditions at 115 V/60 Hz

*** Starting amperage RMS (Root Mean Square) for core unit for first 300 ms

**** Starting amperage RMS (Root Mean Square) for core unit for first 40 ms

+ Recommendation only. Pump size shall be adapted to application constraints in order to always ensure minimal sea water flow.

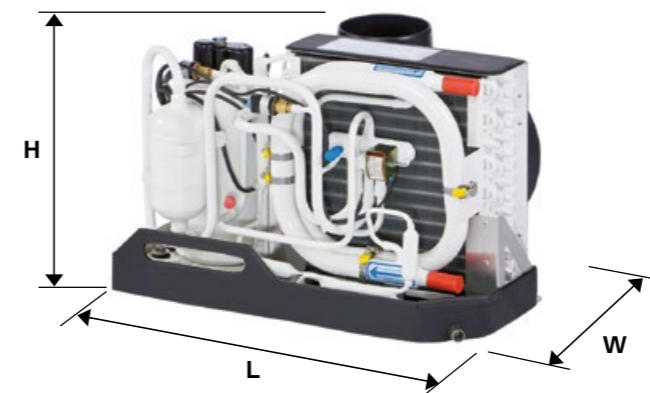

S6 – S20

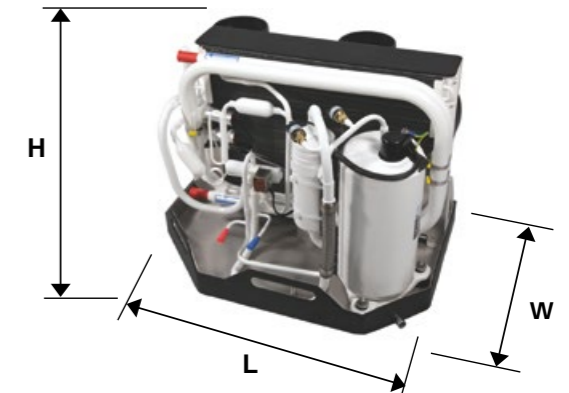

S27

BlueCool Chiller Systems

BlueCool V-Series

The V-Series is offering variable speed compressor technology to the marine market. This innovative technology with inverter driven compressors allows to modulate the cooling output in a wide range but also eliminates the starting peak which permits to downsize the generator. Additionally it has an advanced control system with new comfort features, it automatically adapts to 50/60 Hz and to hot sea water conditions.

BlueCool C-Series

The C-Series stands for standardized chiller units for small to medium boats. The range goes from 16,000 BTU/h to 108,000 BTU/h. Those chillers are the ideal solution for those who demand a high quality product with a short delivery time. The units come in 230 V 50/60 Hz voltage. Customization options are soft starts as well as vibration dampers.

BlueCool P-Series

The P-Series is Webasto's Professional Chiller Series and is designed for mid-size up to super yachts and commercial boats. They cover a large range of cooling performances from 30,000 up to 572,000 BTU/h. All are equipped with 50 to 60 Hz compatible scroll-compressors and up to four compressors are mounted on a single tray. The P-Series is highly customizable with many options such as soft starts, anti-vibration mounts, CAN Bus control, enlarged condensers for operation under tropical conditions, single phase or three phase compressors. Ask Webasto to have your chiller system individually configured to your needs.

BlueCool V-PRO Series

The V-PRO Series is the new variable speed chiller system to build large chilled water systems with 400 V 3-ph power supply. This chiller system consists of four different modular chiller units which may be flexibly combined to provide up to 1 Mio. BTU/h. The V-PRO system comes with a number of intelligent functions and optional accessories to match your demands.

Chiller systems are now compatible with the new MyTouch display



BlueCool MyTouch

BlueCool Chiller Systems Product Overview



BlueCool V-Series
V50 M, V64 T, V77 T

See page 102



BlueCool C-Series
C16 M to C108 Q

See page 104



BlueCool P-Series
P30 M to P572 Q

See page 106



BlueCool V-PRO Series

See page 114

BlueCool Chiller Systems

Application Concept

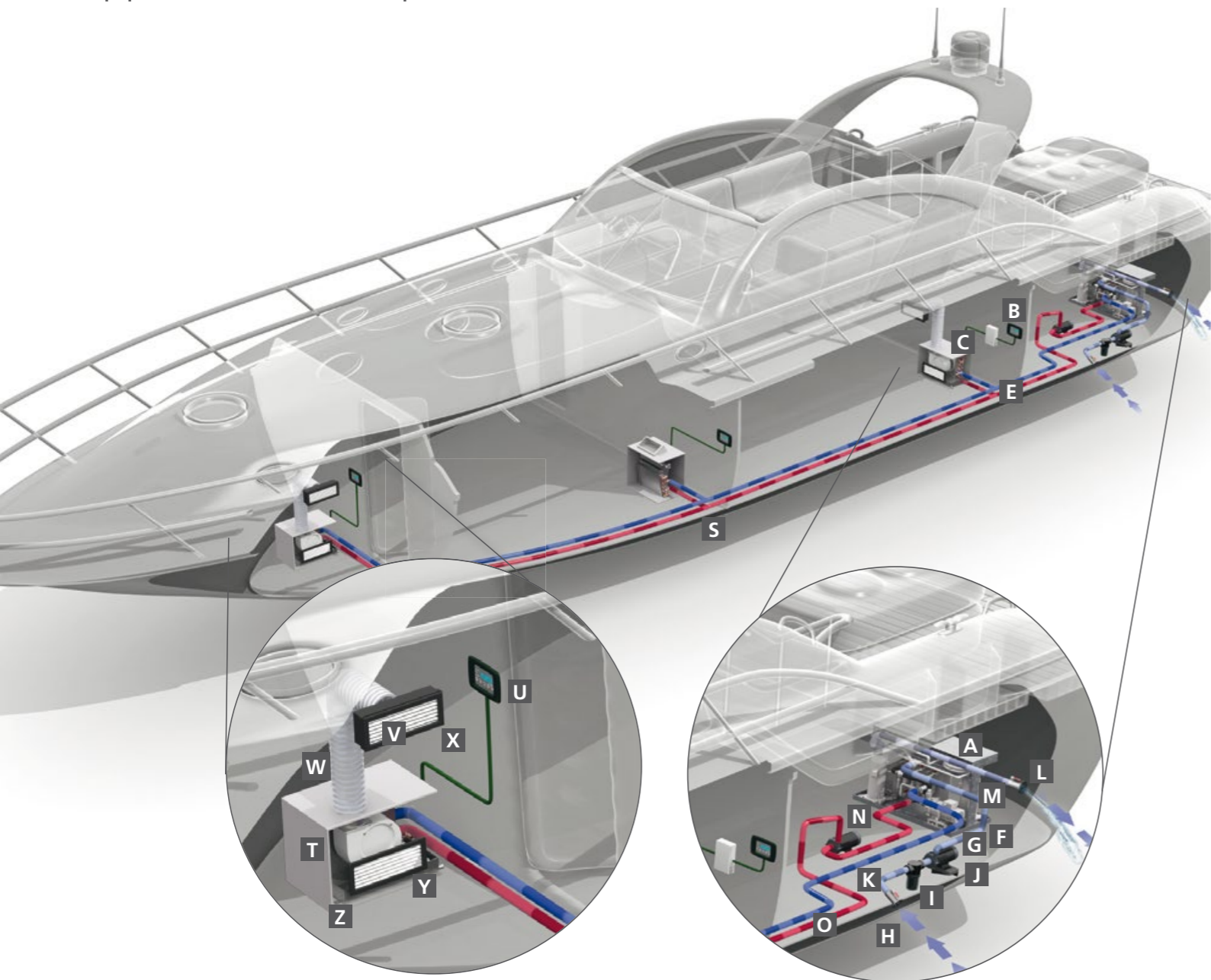

For larger boats with several cabins a chiller system is the best choice. The chiller A/C unit **A** is typically placed in the engine room providing chilled water/glycol to all cabins via the chilled water circuit **N** to **S**. In each cabin one or several air handlers **T** are fitted depending on cooling capacity and space requirements. The Digital Control Panel **B** controls the A/C system itself. For each cabin one Control Panel **U** is needed to individually control the air handler in this cabin. As a result you get full temperature control in each cabin providing maximum comfort on board.

Chiller Air-Conditioning Systems

Whenever three or more independent volumes in a yacht need to be air-conditioned, it becomes worth considering a central chiller system. To distribute cooling capacity over several independently operating air handlers from one single central cooling unit, the most flexible and simple solution is to install a chilled water circulation system between the central unit and the air handlers. This mixed water/glycol circuit is maintained at approx. +4 °C. All Webasto chiller units are equipped with high efficiency multi-plate heat exchangers.

BlueCool Chiller Systems

Application Guidelines

For a complete chiller system, please select the following:

Core unit

Please select the core unit according to the required cooling capacity, the available voltage and whether cool only or heating via reverse cycle is needed.

A Air-conditioning unit [See page 102 – 117](#)

Position **A** as well as the following components are included in the scope of delivery:

- Electric cable and control box
- Installation manual
- Operating manual

Control elements for V-, C- and P-Series

Please select the control elements for the core unit separately:

B MyTouch display [See page 142](#) **C** Display cable [See page 142](#)
D Remote air temperature sensor [See page 142](#)

For V-PRO Series the MyTouch display and display cable are already included in the scope of delivery.

Accessories for V- and C-Series

Please order separately the accessories for the V- and C-Series core unit:

E Soft Starts [See page 160](#) **F** Vibration absorber kits [See page 160](#)
G Silent block kits [See page 160](#)

Sea water circuit

Please order separately the components for the sea water circuit consisting of:

H Sea water inlet [See page 158](#) **I** Sea water strainer [See page 158](#)
J Sea water pump [See page 144](#) **K** Closing valve [See page 158](#)
L Overboard discharge [See page 158](#) **M** Water hose [See page 157](#)

Chilled water circuit

Please add the required components for the chilled water circuit consisting of:

N Circulation pump [See page 144](#) **O** Piping or hosing system [See page 154](#)
P 3-way valve (optional) [See page 157](#) with insulation
Q Turn ball valve [See page 157](#) **R** Expansion tank [See page 157](#)
S T-pieces [See page 157](#)

Cabin accessories necessary for each single cabin

Please add for every single cabin the following components and accessories:

T Air handler [See page 126](#) **U** Cabin control (Control Panel, [See page 142](#)
V Supply air grille [See page 150](#) display cable, temperature sensor
W Air ducting [See page 151](#) and control box
X Transition box [See page 151](#) **Y** Return air grille [See page 150](#)
Z Water hoses for [See page 157](#) condensation drain

BlueCool V-Series

Variable Speed Chiller



V64 T and V77 T



V50 M
without electronic box

BlueCool V-Series

Variable Speed Chiller



Technical data

Type	BlueCool V-Series		
	V50 M	V64 T	V77 T
Order No.	WBCL1203001C	WBCL1203003B	WBCL1203002B
Cooling capacity* (BTU/h)	8,500 – 50,000	8,500 – 64,000	8,500 – 77,000
Cooling capacity* (kW)	2.5 – 14.6	2.5 – 18.7	2.5 – 22.6
Heating via reverse cycle integrated	yes	yes	yes
Voltage (V)	230 (-15%/+10%)	230 (-15%/+10%)	230 (-15%/+10%)
Frequency ++ (Hz)	50/60 (+-5%)	50/60 (+-5%)	50/60 (+-5%)
Current draw running** (A)	2.5 – 15* (max. 17)	2.5 – 23.8 (max. 25)	2.5 – 24 (max. 26.5)
Current draw Start (A)	2.5	2.5	2.5
Current draw Eco 1 Mode (A)	2.5 – 8* (max. 12)	2.5 – 15* (max. 17)	2.5 – 15* (max. 17)
Current draw Eco 2 Mode (A)	2.5 – 5* (max. 8)	2.5 – 8* (max. 12)	2.5 – 8* (max. 12)
Current draw Eco 3 Mode (A)	–	2.5 – 5* (max. 8)	2.5 – 5* (max. 8)
Chilled water connection (mm), (Inch)	25 1"	32 1 1/4" F BST	32 1 1/4" F BST
Min. chilled water flow (l/min.)	35	45	52
Seawater connection (mm), (Inch)	25 1" M BST	32 1 1/4" F BST	32 1 1/4" F BST
Min. seawater flow (l/min.)	38	50	57
Dimensions unit L x D x H (mm), (Inch)	567 x 340 x 510 22.3 x 13.4 x 20.1	760 x 560 x 510 29.9 x 22.0 x 20.1	760 x 560 x 510 29.9 x 22.0 x 20.1
Dimensions unit incl. silent block L x D x H (mm), (Inch)	590 x 378 x 548 23.2 x 14.9 x 21.6	760 x 560 x 550 29.9 x 22.0 x 21.7	760 x 560 x 550 29.9 x 22.0 x 21.7
Dimension electronic box L x D x H (mm), (Inch)	560 x 190 x 465 22.0 x 7.5 x 18.3	560 x 190 x 465 22.0 x 7.5 x 18.3	560 x 190 x 465 22.0 x 7.5 x 18.3
Dimension chiller L x D x H (mm), (Inch)	607 x 530 x 510 23.9 x 20.8 x 20.1	760 x 750 x 510 29.9 x 29.5 x 20.1	760 x 750 x 510 29.9 x 29.5 x 20.1
Dimensions unit incl. silent block + box L x D x H (mm), (Inch)	620 x 570 x 548 24.4 x 22.4 x 21.6	760 x 750 x 550 29.9 x 29.5 x 21.7	760 x 750 x 550 29.9 x 29.5 x 21.7
Ambient temperature limit (°C)	60	60	60
Sound level unit (dB/A) (measured)	49.2	48.5	48.5
Refrigerant charge R410A (g)	892	892 + 770	892 + 770
Weight core unit (kg)	47	90	90
Weight electronic box (kg)	15	15	15
Min. sea water temp. heating (°C)	6	6	6
Max. sea water temp. cooling (°C)	35	35	35

* Based on 7°C evaporating temperature and 38°C condensing temperature

** Amperage values for core unit depend on compressor load. Max values at tropical conditions at 230 V/50 Hz

++ BlueCool V-Series systems are tested and approved by Webasto for 50/60 Hz operation

Works with the MyTouch display



BlueCool MyTouch

The BlueCool V-Series:

- V64 T and V77 T with innovative hybrid control logic
- Large power modulation range: 8,500 up to 77,000 BTU
- Unique hybrid concept reduces output by 89% during part load operation.
- Variable speed BLDC compressors controlled by inverter technology
- Zero electrical starting peak
- Super quiet operation with little noise variations and sound cover housing
- High system availability via dynamic control of HP/LP boundary conditions
- Light and compact
- Preventive maintenance monitoring system
- Condensate free operation
- Easy installation and maintenance
- Low service and operation costs
- Integrates Webasto's BlueCool Expert diagnosis and set up tool
- Up to 3 ECO modes with adjustable amperage draw
- 230 V 50 Hz or 240 V 60 Hz compatible for worldwide application
- MyTouch as standard user interface with clear text display



BlueCool C-Series

Ultra Compact Chiller

Technical data

Type	BlueCool C-Series							
	C16 M	C20 M	C27 M	C32 T	C40 T	C55 T	C81 R	C108 Q
Order numbers	WBCL1205001E	WBCL1205002D	WBCL1205003D	WBCL1207001E	WBCL1207002D	WBCL1207003D	WBCL1207004D	WBCL1207005D
Cooling capacity* (BTU/h)	16,000	20,000	27,000	32,000	40,000	55,000	81,000	108,000
Cooling capacity* (kW)	4.7	5.9	7.9	9.4	11.7	16.1	23.7	31.7
Heating via reverse cycle integrated	yes	yes	yes	yes	yes	yes	yes	yes
Voltage (V)	230 (-15%/+10%)	230 (-15%/+10%)	230 (-15%/+10%)	230 (-15%/+10%)	230 (-15%/+10%)	230 (-15%/+10%)	230 (-15%/+10%)	230 (-15%/+10%)
Frequency ++ (Hz)	50/60 (+-5%)	50/60 (+-5%)	50/60 (+-5%)	50/60 (+-5%)	50/60 (+-5%)	50/60 (+-5%)	50/60 (+-5%)	50/60 (+-5%)
Current draw running** (A)	4.4 – 6.0	6.9 – 8.0	8.6 – 9.2	8.8 – 12.0	13.8 – 16.0	17.2 – 18.4	25.8 – 27.6	34.4 – 36.8
Current draw Start max. peak (A) 50 Hz	54	60	77	60	68	87	97	107
Current draw RMS40**** (A) 50 Hz	35	39	49	41	47	59	69	79
Current draw RMS300*** (A) 50 Hz	19	20	32	25	28	42	52	62
Current draw Start max. peak with Soft Start (A) 50 Hz	22	22	34	28	30	44	54	64
Current draw RMS40**** with Soft Start (A) 50 Hz	12	14	18	18	22	28	38	48
Current draw RMS300 with Soft Start (A) 50 Hz	9	10	17	15	18	27	37	47
Locked Rotor Amperage LRA (A) (comp. only)	37	43	54	37	43	54	54	54
Max. circuit breaker (A)	16	16	20	2 x 16	2 x 16	2 x 20	3 x 20	4 x 20
Chilled water connection (mm)	25	25	25	25	25	25	32	–
Chilled water connection (inch)	1	1	1	1	1	1	1 1/4	1 1/4 F BST
Minimal chilled water flow (l/min.)	13	16	19	26	32	38	57	76
Recommended chilled water pump	WB500	WB500	WB1000	WB1000	WB1500	WB1500	WB2000	WB3500
Seawater connection (mm)	19	19	19	19	25	25	32	–
Seawater connection (inch)	3/4	3/4	3/4	3/4	1	1	1 1/4	1 1/4 F BST
Minimal seawater flow at 50 Hz (l/min.)	14	17	21	28	34	42	63	84
Minimal seawater flow at 60 Hz (l/min.)	17	20	25	34	41	50	75	100
Recommended seawater pump	WB500/ WB500G	WB500/ WB500G	WB1000	WB1000	WB1500/ WB1000G	WB1500/ WB2000	WB2000/ WB2500G	WB3000G
Dimensions L x W x H (mm)	390 x 290 x 355	440 x 330 x 360	440 x 330 x 395	590 x 410 x 500	590 x 410 x 500	590 x 410 x 550	870 x 430 x 575	860 x 640 x 600
Dimensions L x W x H (inch)	15.4 x 11.4 x 14.0	17.3 x 13.0 x 14.0	17.3 x 13.0 x 15.6	23.2 x 16.1 x 19.7	23.2 x 16.1 x 19.7	23.2 x 16.1 x 21.7	33.5 x 16.9 x 22.6	33.9 x 22.4 x 23.6
Weight (kg)	34	37	45	65	70	86	119	173
Min. sea water temp. Heating (°C)	6	6	6	6	6	6	6	6
Max. sea water temp. Cooling (°C)	35	35	35	35	35	35	35	35

General note: Values in this table given for 50 Hz only. 60 Hz data available on request.

* BTU/h are based on 7°C evaporating temperature and 38°C condensing temperature

** Amperage values for core unit depend on compressor load. Max values at tropical conditions at 230 V/50 Hz

*** Starting amperage RMS (Root Mean Square) for core unit for first 300 ms

**** Starting amperage RMS (Root Mean Square) for core unit for first 40 ms

+ Recommendation only. Pump size shall be adapted to application constraints in order to always ensure minimal sea water flow.

++ BlueCool C-Series systems are tested and approved by Webasto for 50/60 Hz operation

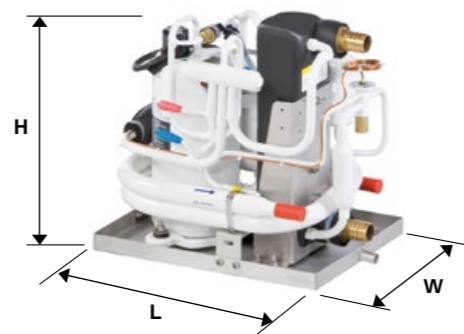

Mono
C16 M – C27 M

BlueCool C-Series

Ultra Compact Chiller



Works with the MyTouch display



BlueCool MyTouch

The BlueCool C-Series:

- Improved performance and up to 15 % higher efficiency
- Continuous cooling capacity even in tropical conditions
- Even more compact design
- Improved electronics for easy installation and diagnosis via USB cable
- Optional CAN-Bus for optimized adaptation to boat systems
- Compressor noise is reduced by up to 25 %
- Easy sea water and chilled water connections at one side
- Strong stainless steel tray and condensate drain
- High quality Epoxy paint protection
- Vibration absorber and Silent block available as an option
- Soft start devices available as an option

BlueCool P-Series

Professional Chiller Series

BlueCool P-Series

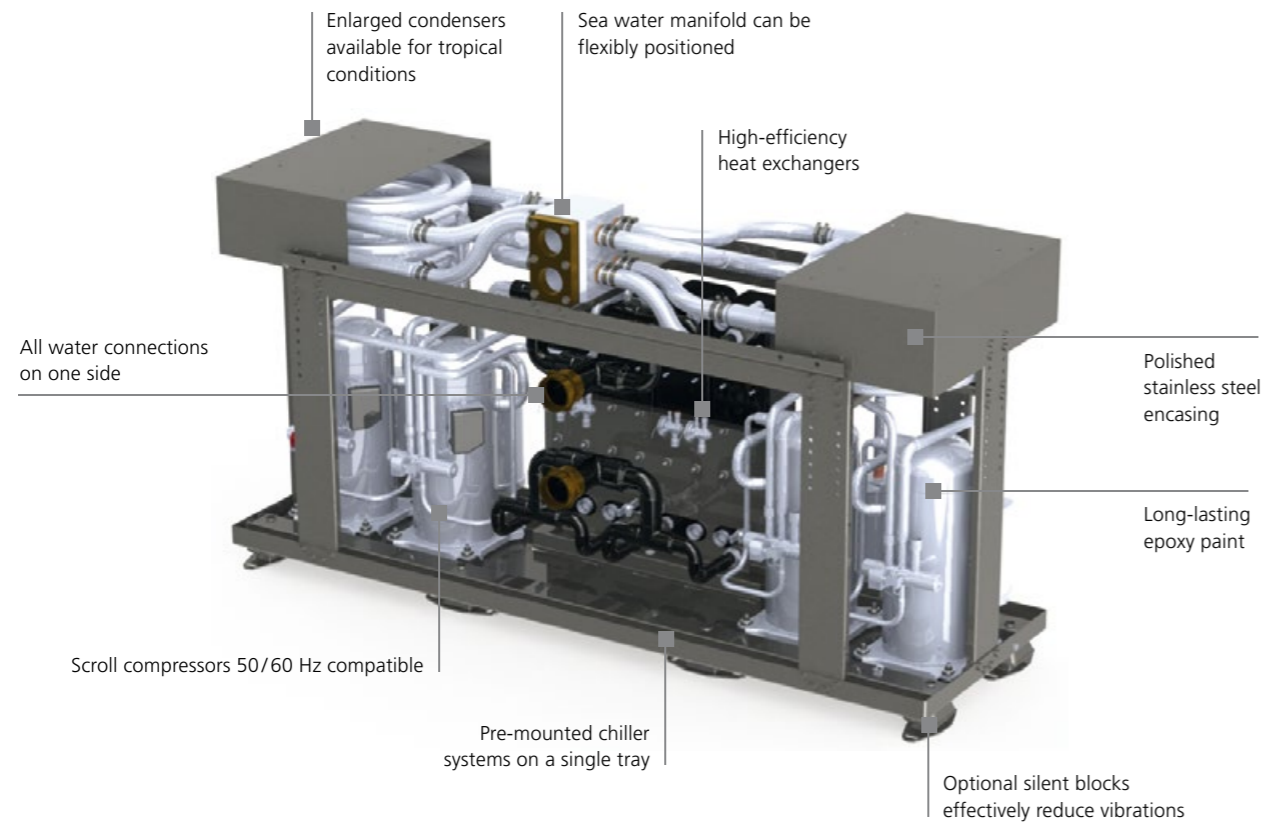

Works with the MyTouch display



BlueCool MyTouch

The professional BlueCool P-Series:

- Professional chiller system for medium to large boats and super yachts
- Highly customizable chiller series with large range of 30,000 – 572,000 BTU/h to adapt to cooling demand
- Successor of our BlueCool Premium scroll compressor range for high reliability
- Multiple compressor units with independent cooling circuits for high availability
- Range extension with 8 new models
- Improved electronics – electronic box with easy access to components – PCB with increased circuit protection, also fulfilling highest EMC standards EN 60945 – the electronic box has been slightly enlarged so that softstarts can be easily integrated into this box
- BlueCool Expert tool for service, configuration, application tuning, diagnosis and system setup comes as a standard free of charge
- Optional CAN-Bus for integration into boats central monitoring systems
- Unique Thermostatic Advance Function for power output continuously adapted to cooling demand
- Redesigned trays for easier mounting of silent blocks to reduce vibrations
- Electrical systems can be upgraded to customer needs with PRO box or fulfilling MCA requirements

BlueCool P-Series

Configuration Options

Configure your chiller system in 6 main steps:

Product options for BlueCool P-Series

The BlueCool P-Series is highly customizable to the demands of shipyards and national legislation. In addition to a wide range of cooling capacities, many options can be selected to customize the chiller to your needs. For further options, please contact the sales support team at Webasto.

Option 1: Voltage

All P-Series chillers are available as 400 V/3-phase version. On most models 208 V/3-phase or 230 V/single phase is available as well.

Option 2: Cool only version

For regions where heating is not required some units are available as cool only version.

Option 3: Tropical version

For high sea water temperatures > 32 °C, a tropical chiller version with enlarged condensers shall be selected to avoid high pressure cut-outs. Option is highly recommended whenever the boat may travel in regions where sea water temperatures may be above 32 °C.

Option 4: Soft start

In order to reduce the amperage draw at compressor start a soft start may be chosen as an option.

- Soft start devices are reducing the amperage peak at compressor start up to 53 %
- Soft start models are available for 400 V 3-phase as well as 230 V single phase
- The peak reduction allows to better size the power generator and it frees capacities for other electrical consumers
- Light flickering is reduced
- Circuit breakers and cables sizes do not have to be oversized
- The soft starts fit into the standard electrical box if no further electrical accessories are chosen
- If the soft starts are selected during the chiller configuration process they come already installed and tested as part of the electronic box





BlueCool P-Series

Configuration Options

Option 5: Electrical upgrades

In the standard configuration, the chiller comes with a standard electrical box which allows to operate the chiller. Webasto offers a wide variety of electrical options which enhance the operation and service comfort or ease the electrical installation. Some options may be required to comply with national standards or requirements coming from the boat's classification society. Depending on the amounts of options chosen the larger PRO box or even a box compliant to MCA standards will be used. Each box will be individually configured to your needs.

			
	Standard Box	Pro Box	MCA Box
Housing			
Material	Galvanized steel, epoxy painted	Mild steel, powder coated	Mild steel, powder coated
IP class	IP21	IP66/NEMA 4, 12, 13/IK 10	IP66/NEMA 4, 12, 13/IK 10
Color	White	RAL 7035	RAL 7035
Opening/closing	Screws	Locking mechanism	Locks with removable handle
Components included			
Chiller electronic card	■	■	■
Relays for compressors, chilled water and sea water pump	■	■	■
Terminal block connectors	■	■	■
Compressor Soft starts	□	□	□
Motor protective relays and circuit breakers for compressors and pumps	-	■	■
Circuit breaker for chiller electronic card	-	■	■
Only one power supply needed for entire unit	-	■	■
Halogen free cables	-	□	■
Cable harness length: 2 m	■	■	■
Increased cable harness length: 5 m/10 m/15 m	□	□	□
Chilled water pump: redundancy selector for two pumps	-	□	□
Sea water pump: redundancy selector for two pumps	-	□	□
Power ON lamp	-	□	■
Pilot lamps for pumps and/or compressors	-	□	■
Digital display integrated at the front door	-	□	□
Compressor running counter	-	□	□
Main switch	-	-	■
Emergency stop	-	-	■
Pushbutton to test pilot lamps	-	-	■
Door locking mechanism in open position	-	□	■
Ampere gauge	-	-	□

■ Standard □ Optional - Not available

Option 6: Silent blocks

Silent blocks may be mounted between the chiller unit and the hull of the boat to reduce structural born vibrations being transferred from the chiller unit into the boat.

- The silent blocks very effectively reduce vibrations into the hull of the boat by up to 50 %
- Silent blocks are mounted below the base plate of the A/C unit
- High performance damping elements specially designed for the vibration frequency and the weight of each unit
- Marine grade with corrosion resistant materials
- Integrated rip-off protection
- If the silent blocks are selected during the chiller configuration process they come already mounted onto the A/C unit
- Please ask for the specific height increase of your unit as the silent block type varies with the size of the units

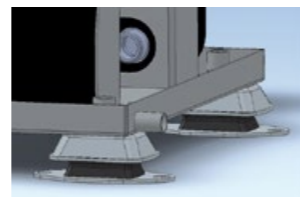

BlueCool P-Series

Project Assistance and Support

A chiller system always needs to be customized to each boat in order to meet the demands of shipyards, owners, classification societies and national legislation. We support you in this process with our expertise and the tools we have developed for this.

Specification and quotation tool

This tool should be used for all A/C projects to

- Precisely calculate the cooling and heating demand for each cabin depending on boat characteristics, performance requirements and usage conditions
 - Determine the fresh air requirements of larger boats
 - Select your bill of material from the entire product portfolio
 - Summarize technical data of the chosen key components
- As a result the chiller and air handlers are correctly sized to the individual demand of each boat.

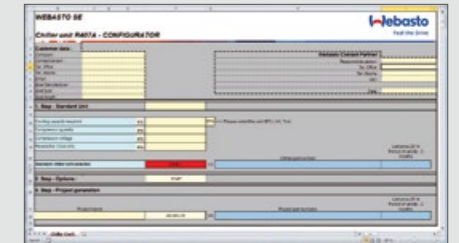

Chiller configurator tool

This tool is used by Webasto to

- Select the available options for a chiller unit, see Options 1, 2, 3, 6 on previous pages
 - Select the available electrical options, see Options 4 and 5 on previous pages
- As a result your chiller and electronic box will receive an individual part number which is uniquely used for your project.

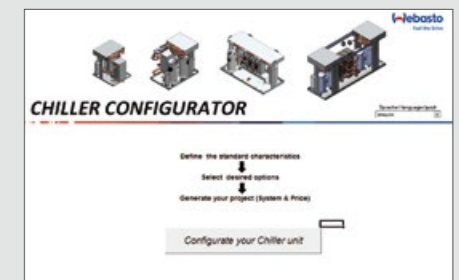

Engineering support

Our project engineers support you in various phases of a project delivering to you

- A/C system concepts
- Piping diagrams
- Electrical wiring schematics
- On-site support to understand and determine the optimal A/C configuration

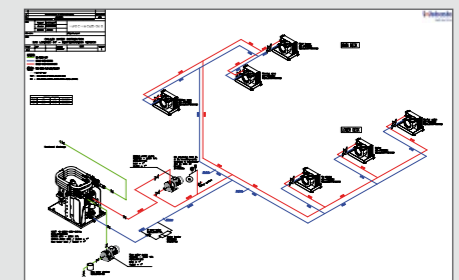

Installation and commissioning support

Our project engineers can support you on demand during the installation and commissioning phase of your project with

- Technical support to answer your questions
- On-site support and audit
- Check of your installation
- Support during system commissioning



BlueCool P-Series

Professional Chiller Series



BlueCool P-Series Mono chiller											
Type	P30 M	P36 M	P42 M	P48 M	P60 M	P72 M	P84 M	P96 M	P112 M	P126 M	P143 M
Cooling capacity* (BTU/h)	30,000	36,000	42,000	48,000	60,000	72,000	84,000	96,000	112,000	126,000	143,000
Cooling capacity* (kW)	8.7	10.5	12.3	14	17.6	21.1	24.6	28.1	32.8	36.9	41.8
Frequency (Hz)*****	50/60	50/60	50/60	50/60	50/60	50/60	50/60	50/60	50/60	50/60	50/60
Current draw running** (A) for 230 V 1-phase	6.8	8	9.4	12	-	-	-	-	-	-	-
Current draw running** (A) for 400 V 3-phase	2.9	3.5	4.1	5.1	5.9	6.5	8.4	10	11	12	13
Current draw running** (A) for 208 V 3-phase	5.0	6.1	6.9	8.5	-	13	24	-	-	-	-
Current draw running FLA**** (A) for 230 V 1-phase	15	17	23	24	-	-	-	-	-	-	-
Current draw running FLA**** (A) for 400 V 3-phase	5.1	5.6	7	10	11	12	15	16	17	20	22
Current draw running FLA**** (A) for 208 V 3-phase	10	11	14	19	25	27	25	-	-	-	-
Locked Rotor Amperage LRA (A) for Single compressor 230 V 1-phase	61	76	100	114	-	-	-	-	-	-	-
Locked Rotor Amperage LRA (A) for Single compressor 400 V 3-phase	32	40	46	50	59	74	101	95	111	118	118
Locked Rotor Amperage LRA (A) for Single compressor 208 V 3-phase	70	83	95	98	139	172	179	-	-	-	-
Min. chilled water flow (l/min.)	25	30	33	38	50	60	66	76	88	104	117
Min. seawater flow (l/min.)	19	22	27	30	38	46	56	64	68	82	93
Recommended seawater pump+	WB1000	WB1000	WB1000 WB1500	WB1000 WB1500	WB1500	WB2500G WB3000G	WB2500G WB3000G	WB2500G WB3000G	WB3000G WB3500	WB3000G WB3500	WB3000G WB3500
Dimensions (L x W x H) (mm)	425 x 506 x 547	425 x 506 x 547	425 x 506 x 547	425 x 506 x 547	560 x 610 x 602	560 x 610 x 727	560 x 610 x 727	560 x 615 x 727	560 x 811 x 727	560 x 811 x 827	560 x 845 x 827
Dimensions (L x W x H) (inch)	16.7 x 19.9 x 21.5	16.7 x 19.9 x 21.5	16.7 x 19.9 x 21.5	16.7 x 19.9 x 21.5	22 x 24 x 23.7	22 x 24 x 28.6	22 x 24 x 28.6	22 x 24.2 x 28.6	22 x 31.9 x 28.6	22 x 31.9 x 32.6	22 x 33.3 x 32.6
Dimensions (L x W x H) (mm) tropical	425 x 506 x 547	425 x 506 x 547	425 x 506 x 547	425 x 506 x 547	560 x 610 x 602	560 x 610 x 727	560 x 610 x 727	560 x 615 x 727	560 x 811 x 727	560 x 811 x 827	560 x 845 x 827
Dimensions (L x W x H) (inch) tropical	16.7 x 19.9 x 21.5	16.7 x 19.9 x 21.5	16.7 x 19.9 x 21.5	16.7 x 19.9 x 21.5	22 x 24 x 23.7	22 x 24 x 28.6	22 x 24 x 28.6	22 x 24.2 x 28.6	22 x 31.9 x 28.6	22 x 31.9 x 32.6	22 x 33.3 x 32.6
Weight (kg)	55	66	68	70	75	80	85	90	100	110	125
Available options											
230 V/1-phase	<input type="checkbox"/>	<input type="checkbox"/>	<input type="checkbox"/>	<input type="checkbox"/>	-	-	-	-	-	-	-
208 V/3-phase	<input type="checkbox"/>	<input type="checkbox"/>	<input type="checkbox"/>	<input type="checkbox"/>	<input type="checkbox"/>	<input type="checkbox"/>	<input type="checkbox"/>	-	-	-	-
Reverse Cycle Heating	<input checked="" type="checkbox"/>	<input checked="" type="checkbox"/>	<input checked="" type="checkbox"/>	<input checked="" type="checkbox"/>	<input checked="" type="checkbox"/>	<input checked="" type="checkbox"/>	<input checked="" type="checkbox"/>	<input checked="" type="checkbox"/>	<input checked="" type="checkbox"/>	<input checked="" type="checkbox"/>	<input checked="" type="checkbox"/>
Cool Only version	-	-	-	-	-	-	-	-	-	-	-
Tropicalized version	<input type="checkbox"/>	<input checked="" type="checkbox"/>	<input type="checkbox"/>	<input checked="" type="checkbox"/>	<input type="checkbox"/>	<input checked="" type="checkbox"/>	<input type="checkbox"/>	<input type="checkbox"/>	<input type="checkbox"/>	<input checked="" type="checkbox"/>	<input type="checkbox"/>
Soft Start 400 V/230 V/208 V	<input type="checkbox"/> / <input type="checkbox"/> /-	<input type="checkbox"/> / <input type="checkbox"/> /-	<input type="checkbox"/> / <input type="checkbox"/> /-	<input type="checkbox"/> /-/-	<input type="checkbox"/> /-/-	<input type="checkbox"/> /-/-	<input type="checkbox"/> /-/-	<input type="checkbox"/> /-/-	<input type="checkbox"/> /-/-	<input type="checkbox"/> /-/-	<input type="checkbox"/> /-/-
Upgrade box/MCA Box	<input type="checkbox"/>	<input type="checkbox"/>	<input type="checkbox"/>	<input type="checkbox"/>	<input type="checkbox"/>	<input type="checkbox"/>	<input type="checkbox"/>	<input type="checkbox"/>	<input type="checkbox"/>	<input type="checkbox"/>	<input type="checkbox"/>
Silent Block	<input type="checkbox"/>	<input type="checkbox"/>	<input type="checkbox"/>	<input type="checkbox"/>	<input type="checkbox"/>	<input type="checkbox"/>	<input type="checkbox"/>	<input type="checkbox"/>	<input type="checkbox"/>	<input type="checkbox"/>	<input type="checkbox"/>

General note: Values in this table given for 50 Hz only. 60 Hz data available on request. Standard Optional - Not available

* BTU/h are based on 7°C evaporating temperature and 38°C condensing temperature.

** Amperage values for core unit at nominal conditions at 50 Hz.

**** FLA (Full Load Amperage) is the current draw at maximum conditions.

+ Recommendation only. Pump size shall be adapted to application constraints in order to always ensure minimal sea water flow.

++ BlueCool P-Series systems are tested and approved by Webasto for 50/60 Hz operation.

BlueCool P-Series Twin chiller					
Type	P60 T	P72 T	P84 T	P96 T	P120 T
Cooling capacity* (BTU/h)	60,000	72,000	84,000	96,000	120,000
Cooling capacity* (kW)	17.6	21.1	24.6	28.1	35.2
Frequency (Hz)	50/60	50/60	50/60	50/60	50/60
Current draw running** (A) for 230 V 1-phase	14	16	19	25	-
Current draw running** (A) for 400 V 3-phase	5.8	7.1	8.1	10	12
Current draw running** (A) for 208 V 3-phase	10	12	14	17	33
Current draw running FLA**** (A) for 230 V 1-phase	30	35	46	47	-
Current draw running FLA**** (A) for 400 V 3-phase	10	11	14	20	22
Current draw running FLA**** (A) for 208 V 3-phase	20	22	27	37	50
Locked Rotor Amperage LRA (A) for Single compressor 230 V 1-phase	61	76	100	114	-
Locked Rotor Amperage LRA (A) for Single compressor 400 V 3-phase	32	40	46	50	59
Locked Rotor Amperage LRA (A) for Single compressor 208 V 3-phase	70	83	95	98	139
Min. chilled water flow (l/min.)	50	60	66	76	100
Min. seawater flow (l/min.)	38	46	56	64	80
Recommended seawater pump+	WB1500 WB2000	WB2500G WB3000G	WB2500G WB3000G	WB2500G WB3000G	WB3000G WB3500
Dimensions (L x W x H) (mm)	560 x 660 x 600	560 x 694 x 625	560 x 694 x 625	560 x 683 x 675	560 x 790 x 675
Dimensions (L x W x H) (inch)	22 x 26 x 23.6	22 x 27.3 x 24.6	22 x 27.3 x 24.6	22 x 26.9 x 26.6	22 x 31.1 x 26.6
Dimensions (L x W x H) (mm) tropical	560 x 660 x 625	560 x 694 x 625	560 x 694 x 625	560 x 683 x 675	560 x 790 x 725
Dimensions (L x W x H) (inch) tropical	22 x 26 x 24.6	22 x 27.3 x 24.6	22 x 27.3 x 24.6	22 x 26.9 x 26.6	22 x 31.1 x 28.5
Weight (kg)	90	95	100	130	160
Available options					
230 V/1-phase	<input type="checkbox"/>	<input type="checkbox"/>	<input type="checkbox"/>	<input type="checkbox"/>	-
208 V/3-phase	<input type="checkbox"/>	<input type="checkbox"/>	<input type="checkbox"/>	<input type="checkbox"/>	<input type="checkbox"/>
Reverse Cycle Heating	<input checked="" type="checkbox"/>	<input checked="" type="checkbox"/>	<input checked="" type="checkbox"/>	<input checked="" type="checkbox"/>	<input checked="" type="checkbox"/>
Cool Only version	-	-	-	-	-
Tropicalized version	<input type="checkbox"/>	<input checked="" type="checkbox"/>	<input type="checkbox"/>	<input checked="" type="checkbox"/>	<input type="checkbox"/>
Soft Start 400 V/230 V/208 V	<input type="checkbox"/> / <input type="checkbox"/> /-	<input type="checkbox"/> / <input type="checkbox"/> /-	<input type="checkbox"/> / <input type="checkbox"/> /-	<input type="checkbox"/> /-/-	<input type="checkbox"/> /-/-
Upgrade box/MCA Box	<input type="checkbox"/>	<input type="checkbox"/>	<input type="checkbox"/>	<input type="checkbox"/>	<input type="checkbox"/>
Silent Block	<input type="checkbox"/>	<input type="checkbox"/>	<input type="checkbox"/>	<input type="checkbox"/>	<input type="checkbox"/>

General note: Values in this table given for 50 Hz only. 60 Hz data available on request. Standard Optional - Not available

* BTU/h are based on 7°C evaporating temperature and 38°C condensing temperature.

** Amperage values for core unit at nominal conditions at 50 Hz.

**** FLA (Full Load Amperage) is the current draw at maximum conditions.

+ Recommendation only. Pump size shall be adapted to application constraints in order to always ensure minimal sea water flow.

++ BlueCool P-Series systems are tested and approved by Webasto for 50/60 Hz operation.

The BlueCool P-Series:

- Wide product range for medium and large size boats
- Scroll compressors for heavy duty applications
- Low starting surge through staged compressor starts
- 208 V, 230 V and 400 V systems available
- Many customization options with different electronics, tropical versions, vibration damping and many other features
- Fully independent refrigerant circuits in multiple compressor units provide high system availability
- Power output continuously adapted to cooling demand
- Very robust stainless steel design for heavy duty use

BlueCool P-Series

Professional Chiller Series

Webasto engineers can quote custom manufactured chiller systems upon request. Please contact us for a tailored solution to fit your individual needs.

Type	BlueCool P-Series Triple chiller				
	P126 R	P144 R	P180 R	P216 R	P252 R
Cooling capacity* (BTU/h)	126,000	144,000	180,000	216,000	252,000
Cooling capacity* (kW)	37	42.2	52.8	63.3	73.8
Frequency (Hz)	50/60	50/60	50/60	50/60	50/60
Current draw running** (A) for 230 V 1-phase	28	37	-	-	-
Current draw running** (A) for 400 V 3-phase	12	15	18	20	25
Current draw running** (A) for 208 V 3-phase	21	26	50	38	72
Current draw running FLA **** (A) for 230 V 1-phase	69	71	-	-	-
Current draw running FLA **** (A) for 400 V 3-phase	21	30	33	36.3	45
Current draw running FLA **** (A) for 208 V 3-phase	40	56	75	81	76
Locked Rotor Amperage LRA (A) for Single compressor 230 V 1-phase	100	114	-	-	-
Locked Rotor Amperage LRA (A) for Single compressor 400 V 3-phase	46	50	59	74	101
Locked Rotor Amperage LRA (A) for Single compressor 208 V 3-phase	95	98	139	172	179
Min. chilled water flow (l/min.)	104	115	138	158	180
Min. seawater flow (l/min.)	82	92	106	125	145
Recommended seawater pump+	WB3000G WB3500	WB3000G WB3500	WB5500	WB5500	WB5500
Dimensions (L x W x H) (mm)	640 x 1,250 x 765	640 x 1,250 x 765	640 x 1,250 x 765	640 x 1,250 x 840	640 x 1,250 x 840
Dimensions (L x W x H) (inch)	25.2 x 49.2 x 30.1	25.2 x 49.2 x 30.1	25.2 x 49.2 x 30.1	25.2 x 49.2 x 33.1	25.2 x 49.2 x 33.1
Dimensions (L x W x H) (mm) tropical	640 x 1,250 x 765	640 x 1,250 x 765	640 x 1,250 x 840	640 x 1,250 x 840	640 x 1,250 x 840
Dimensions (L x W x H) (inch) tropical	25.2 x 49.2 x 30.1	25.2 x 49.2 x 30.1	25.2 x 49.2 x 33.1	25.2 x 49.2 x 33.1	25.2 x 49.2 x 33.1
Weight (kg)	180	190	210	250	260
Available options					
230 V/1-phase	<input type="checkbox"/>	<input type="checkbox"/>	-	-	-
208 V/3-phase	<input type="checkbox"/>	<input type="checkbox"/>	<input type="checkbox"/>	<input type="checkbox"/>	<input type="checkbox"/>
Reverse Cycle Heating	<input checked="" type="checkbox"/>	<input checked="" type="checkbox"/>	<input checked="" type="checkbox"/>	<input checked="" type="checkbox"/>	<input checked="" type="checkbox"/>
Cool Only version	<input type="checkbox"/>	<input type="checkbox"/>	<input type="checkbox"/>	<input type="checkbox"/>	<input type="checkbox"/>
Tropicalized version	<input type="checkbox"/>	<input checked="" type="checkbox"/>	<input type="checkbox"/>	<input checked="" type="checkbox"/>	<input type="checkbox"/>
Soft Start 400 V/230 V/208 V	<input type="checkbox"/> / <input type="checkbox"/> / -	<input type="checkbox"/> / - / -	<input type="checkbox"/> / - / -	<input type="checkbox"/> / - / -	<input type="checkbox"/> / - / -
Upgrade box/MCA Box	<input type="checkbox"/>	<input type="checkbox"/>	<input type="checkbox"/>	<input type="checkbox"/>	<input type="checkbox"/>
Silent Block	<input type="checkbox"/>	<input type="checkbox"/>	<input type="checkbox"/>	<input type="checkbox"/>	<input type="checkbox"/>

General note: Values in this table given for 50 Hz only. 60 Hz data available on request. Standard Optional - Not available

* BTU/h are based on 7°C evaporating temperature and 38°C condensing temperature.

** Amperage values for core unit at nominal conditions at 50 Hz.

**** FLA (Full Load Amperage) is the current draw at maximum conditions.

+ Recommendation only. Pump size shall be adapted to application constraints in order to always ensure minimal sea water flow.

++ BlueCool P-Series systems are tested and approved by Webasto for 50/60 Hz operation.

Type	BlueCool P-Series Quattro chiller										
	P120 Q	P144 Q	P168 Q	P192 Q	P240 Q	P288 Q	P336 Q	P384 Q	P448 Q	P504 Q	P572 Q
Cooling capacity* (BTU/h)	120,000	144,000	168,000	192,000	240,000	288,000	336,000	384,000	448,000	504,000	572,000
Cooling capacity* (kW)	35	42.2	49.2	56.2	70	85	99	112	132	148	168
Frequency (Hz)	50/60	50/60	50/60	50/60	50/60	50/60	50/60	50/60	50/60	50/60	50/60
Current draw running** (A) for 230 V 1-phase	27	32	38	49	-	-	-	-	-	-	-
Current draw running** (A) for 400 V 3-phase	12	14	16	21	23	26	34	40	43	49	53
Current draw running** (A) for 208 V 3-phase	20	24	28	34	66	51	95	-	-	-	-
Current draw running FLA **** (A) for 230 V 1-phase	59	69	92	94	-	-	-	-	-	-	-
Current draw running FLA **** (A) for 400 V 3-phase	20	22	28	40	44	48	60	64	67	78	89
Current draw running FLA **** (A) for 208 V 3-phase	41	44	54	74	100	108	100	-	-	-	-
Locked Rotor Amperage LRA (A) for Single compressor 230 V 1-phase	61	76	100	114	-	-	-	-	-	-	-
Locked Rotor Amperage LRA (A) for Single compressor 400 V 3-phase	32	40	46	50	59	74	101	95	111	118	118
Locked Rotor Amperage LRA (A) for Single compressor 208 V 3-phase	70	83	95	98	139	172	179	-	-	-	-
Min. chilled water flow (l/min.)	100	115	132	161	175	220	245	275	310	360	420
Min. seawater flow (l/min.)	80	92	100	115	140	162	180	200	240	270	325
Recommended seawater pump+	WB3000G WB3500	WB5500	WB5500	WB5500	WB5500	WB5500 WB7400	WB5500 WB7400	WB7400	WB7400 WB9800	WB7400 WB9800	WB7400 WB9800
Dimensions (L x W x H) (mm)	1,390 x 560 x 640	1,390 x 560 x 665	1,715 x 560 x 850	1,715 x 560 x 850	1,715 x 560 x 850	1,715 x 560 x 850	1,715 x 560 x 850	2,030 x 635 x 843	2,030 x 635 x 918	2,030 x 635 x 1,067	2,030 x 635 x 1,068
Dimensions (L x W x H) (inch)	54.7 x 22 x 25.2	54.7 x 22 x 26.2	67.5 x 22 x 33.5	67.5 x 22 x 33.5	67.5 x 22 x 33.5	67.5 x 22 x 33.5	67.5 x 22 x 33.5	79.9 x 25 x 33.2	79.9 x 25 x 36.1	79.9 x 25 x 42	79.9 x 25 x 42
Dimensions (L x W x H) (mm) tropical	1,390 x 560 x 665	1,390 x 560 x 665	1,715 x 560 x 850	1,715 x 560 x 850	1,715 x 560 x 850	1,715 x 560 x 850	1,715 x 560 x 850	2,030 x 635 x 843	2,030 x 635 x 1,068	2,030 x 635 x 1,068	2,030 x 635 x 1,068
Dimensions (L x W x H) (inch) tropical	54.7 x 22 x 26.2	54.7 x 22 x 26.2	67.5 x 22 x 33.5	67.5 x 22 x 33.5	67.5 x 22 x 33.5	67.5 x 22 x 33.5	67.5 x 22 x 33.5	79.9 x 25 x 33.2	79.9 x 25 x 42	79.9 x 25 x 42	79.9 x 25 x 42
Weight (kg)	190	210	285	307	339	350	350	450	670	670	725
Available options											
230 V/1-phase	<input type="checkbox"/>	<input type="checkbox"/>	<input type="checkbox"/>	<input type="checkbox"/>	-	-	-	-	-	-	-
208 V/3-phase	<input type="checkbox"/>	<input type="checkbox"/>	<input type="checkbox"/>	<input type="checkbox"/>	<input type="checkbox"/>	<input type="checkbox"/>	<input type="checkbox"/>	-	-	-	-
Reverse Cycle Heating	<input checked="" type="checkbox"/>	<input checked="" type="checkbox"/>	<input checked="" type="checkbox"/>	<input checked="" type="checkbox"/>	<input checked="" type="checkbox"/>	<input checked="" type="checkbox"/>	<input checked="" type="checkbox"/>	<input checked="" type="checkbox"/>	<input checked="" type="checkbox"/>	<input checked="" type="checkbox"/>	<input checked="" type="checkbox"/>
Cool Only version	<input type="checkbox"/>	<input type="checkbox"/>	<input type="checkbox"/>	-	<input type="checkbox"/>	<input type="checkbox"/>	<input type="checkbox"/>	<input type="checkbox"/>	<input type="checkbox"/>	<input type="checkbox"/>	<input type="checkbox"/>
Tropicalized version	<input type="checkbox"/>	<input checked="" type="checkbox"/>	<input type="checkbox"/>	<input checked="" type="checkbox"/>	<input type="checkbox"/>	<input checked="" type="checkbox"/>	<input type="checkbox"/>	<input type="checkbox"/>	<input type="checkbox"/>	<input checked="" type="checkbox"/>	<input type="checkbox"/>
Soft Start 400 V/230 V/208 V	<input type="checkbox"/> / <input type="checkbox"/> / -	<input type="checkbox"/> / <input type="checkbox"/> / -	<input type="checkbox"/> / <input type="checkbox"/> / -	<input type="checkbox"/> / - / -	<input type="checkbox"/> / - / -	<input type="checkbox"/> / - / -	<input type="checkbox"/> / - / -	<input type="checkbox"/> / - / -	<input type="checkbox"/> / - / -	<input type="checkbox"/> / - / -	<input type="checkbox"/> / - / -
Upgrade box/MCA Box	<input type="checkbox"/>	<input type="checkbox"/>	<input type="checkbox"/>	<input type="checkbox"/>	<input type="checkbox"/>	<input type="checkbox"/>	<input type="checkbox"/>	<input checked="" type="checkbox"/>	<input checked="" type="checkbox"/>	<input checked="" type="checkbox"/>	<input checked="" type="checkbox"/>
Silent Block	<input type="checkbox"/>	<input type="checkbox"/>	<input type="checkbox"/>	<input type="checkbox"/>	<input type="checkbox"/>	<input type="checkbox"/>	<input type="checkbox"/>	<input type="checkbox"/>	<input type="checkbox"/>	<input type="checkbox"/>	<input type="checkbox"/>

Standard Optional - Not available

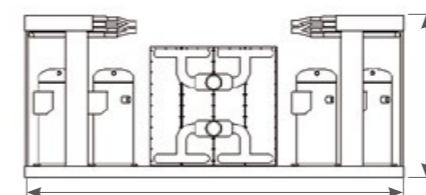
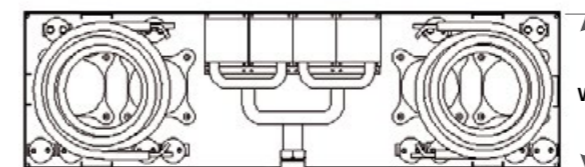

General note: Values in this table given for 50 Hz only. 60 Hz data available on request.

* BTU/h are based on 7°C evaporating temperature and 38°C condensing temperature.

** Amperage values for core unit at nominal conditions at 50 Hz.

**** FLA (Full Load Amperage) is the current draw at maximum conditions.

+ Recommendation only. Pump size shall be adapted to application constraints in order to always ensure minimal sea water flow.

++ BlueCool P-Series systems are tested and approved by Webasto for 50/60 Hz operation.

BlueCool V-PRO Series

Professional Variable Speed Chiller Series



BlueCool V-PRO Series

Professional Variable Speed Chiller Series

NEW

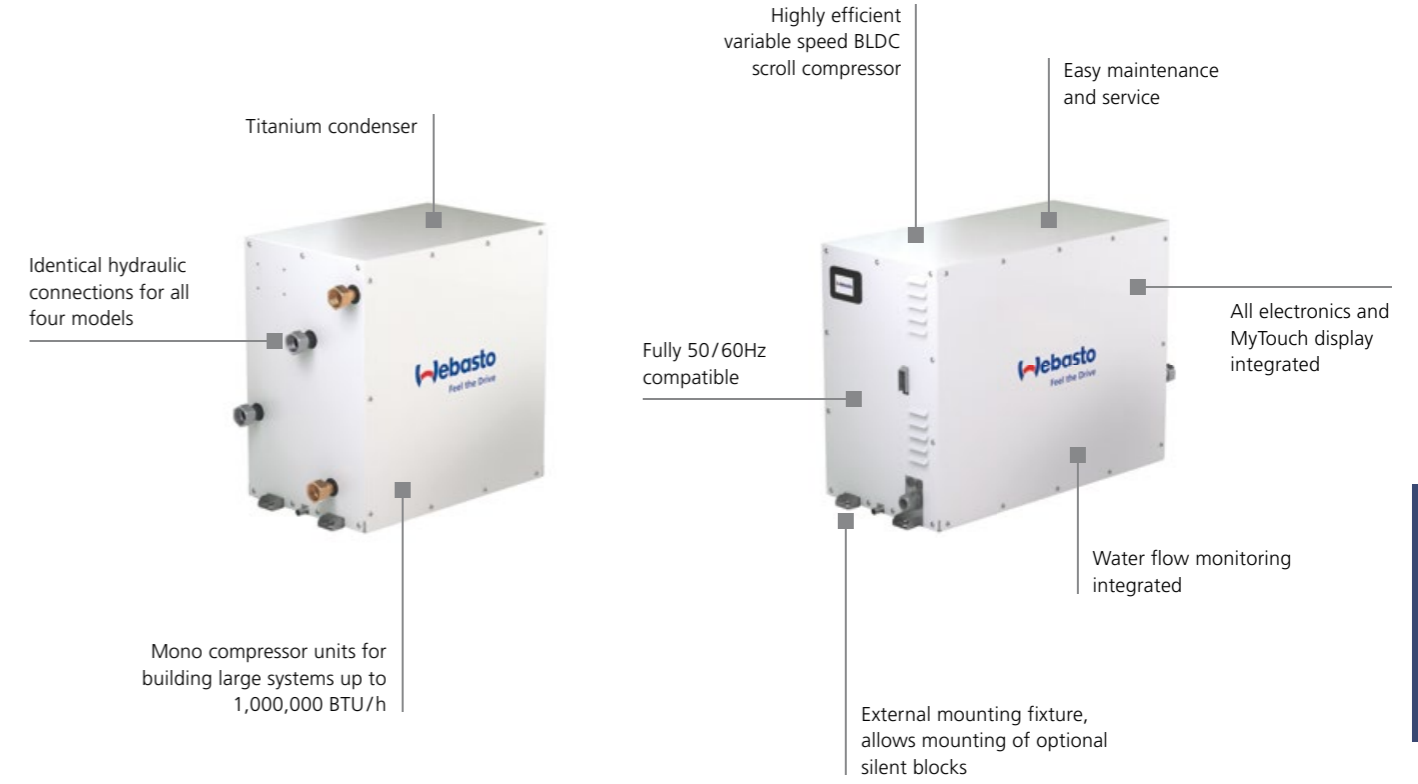

Four models – two sizes – ONE system

Four modular units of 60, 90, 130 or 180 kBTU/h, providing up to 1 Mio. BTU/h of system cooling capacity.

High system availability

Fully autonomous units continue operation. Redundancy at its best.

Water flow monitoring

Integrated Flow monitoring system of sea and chilled water circuit to ensure safe and reliable operation.

Outstanding corrosion & erosion resistance

Titanium sea water heat exchanger for outstanding corrosion resistance.

Variable speed technology for best efficiency

Highest cooling performance with high efficiency inverter, variable speed scroll compressor and energy saving ECO modes.

Unified hydraulic connection

Layout of hydraulic connection is identical for all four models.

Powerful user interface

Full color touch-screen display. Fully redundant, each shows overall system data. Multiple languages.

Combination of autonomous units

Simple network cable immediately creates overall system control.

- Mono variable speed compressor units for building large systems up to 1,080,000 BTU/h
- Four modular units with 60, 90, 130 and 180 kBTU/h available
- Individual system with up to 6 units in one stack
- Combination of different capacities in one stack
- Individual accessories like manifold and rack available
- Modular concept allows fast availability
- Easy service and maintenance
- 400 V (50 Hz) – 460 V (60 Hz) 3-phase+N system
- Integrated electronics
- Customized Master Control Box available to meet additional requirements of customers or classification societies for larger vessels e.g. Lloyd, DNVGL

BlueCool V-PRO Series

Controls



Intuitive and powerful user interface

The full color touch-screen user interface which comes with each unit allows full operation, system set-up and parametrization of the A/C unit. Vital system information is available at a glance. For full redundancy, each user interface can show the data of each individual unit as well as overall system data. Customers will enjoy the ease of use, also thanks to full text explanations in multiple Languages.

BlueCool V-PRO Series

Technical Data



	BlueCool V-PRO Series			
	V-PRO 60M	V-PRO 90M	V-PRO 130M	V-PRO 180M
Order No.	2510228A	2510229A	2510230A	2510231A
Cooling capacity* (BTU/h)	15,000 – 60,000	22,500 – 90,000	19,500 – 130,000	27,000 – 180,000
Cooling capacity* (kW)	4.4 – 17.6	6.6 – 26.4	5.7 – 38.1	7.9 – 52.8
Heating via reverse cycle integrated	yes	yes	yes	yes
Voltage (V)	360 – 480 (+-10%)	360 – 480 (+-10%)	360 – 480 (+-10%)	360 – 480 (+-10%)
Phase	3-ph + N	3-ph + N	3-ph + N	3-ph + N
Frequency ++ (Hz)	50/60 (+-5%)	50/60 (+-5%)	50/60 (+-5%)	50/60 (+-5%)
Current draw running** (A)	13	26.8	34.7	40
Current draw Eco 1 Mode (A)	9.6	18.5	23.5	33
Current draw Eco 2 Mode (A)	6.8	13.1	15.8	22
Current draw Eco 3 Mode (A)	5	9.9	12.4	17
Chilled water connection (mm), (Inch)	32 1 1/4"	32 1 1/4"	32 1 1/4"	32 1 1/4"
Min. chilled water flow (l/min.)	64	95	125	160
Seawater connection (mm), (Inch)	32 1 1/4"	32 1 1/4"	32 1 1/4"	32 1 1/4"
Min. seawater flow (l/min.)	60	92	120	150
Dimensions unit L x D x H (mm), (Inch)	630 x 410 x 650 24.8 x 16.1 x 25.6	630 x 410 x 650 24.8 x 16.1 x 25.6	830 x 410 x 650 32.7 x 16.1 x 25.6	830 x 410 x 650 32.7 x 16.1 x 25.6
Dimensions unit incl. silent block L x D x H (mm), (Inch)	653 x 470 x 700 25.7 x 18.5 x 27.6	653 x 470 x 700 25.7 x 18.5 x 27.6	853 x 470 x 700 33.6 x 18.5 x 27.6	853 x 470 x 700 33.6 x 18.5 x 27.6
Ambient temperature limit (°C)	70	70	70	70
Weight core unit (kg)	89	97	120	136
Min. sea water temp. heating (°C)	5	5	5	5
Max. sea water temp. cooling (°C)	40	40	40	40

* BTU/h are based on 7°C/12°C chilled water temperature and 30°C/35°C sea water temperature.

** Amperage values for core unit at nominal conditions at 50 Hz.

++ BlueCool V-PRO Series are tested and approved for 50/60 Hz operation.

BlueCool V-PRO Series

Configuration Options

The modular design allows customers to combine several units to larger A/C systems reaching cooling capacities between 60 and 1,080 kBTU/h which covers boats between 10 and 80 m of length. The design allows to group them horizontally or vertically in order to match any cooling demand or available installation space on board.

Step 1: Choose the required number and capacity of V-PRO chiller units to achieve required cooling demand for your system.

Step 2: Add one of the Electronic boxes to the system to suit your needs. The minimum required box is the Pump Control Box. Alternatively the Remote Connection Box or one of the Master Control Boxes may be chosen.

Step 3: If the chiller units shall be installed into a rack, choose the required rack system out of 7 options to stack units side by side or on top of each other.

Step 4: Add preconfigured manifold sets to simplify hydraulic connections. Those are equipped with valve valves for each sea and chilled water connection to ensure easy exchange of complete units.

BlueCool V-PRO Series

Electronic Control Box Options

NEW

Pump Control Box for installation of pump relays at remote place, e.g. near the pumps. Easy connection to one of the chiller units via a display/network cable with RJ45 connector.

Remote Connection Box to monitor and control your V-PRO system from any place on board. It features an additional MyTouch display providing an easy system overview. It contains pump relays, 3 programmable relay outputs and an electronic card with USB interface to connect the BlueCool Expert Tool. Installation possible at remote places to enable central access and operation of the complete system.

Master Control Box combines functionality of pump control and remote connection box plus providing central power supply with power indicator, central ON/OFF and emergency stop, circuit breaker for V-PRO units, PCB and pump selector switch. It also features a transformer which allows to use a central power supply of 400 V 3-ph without neutral wire.

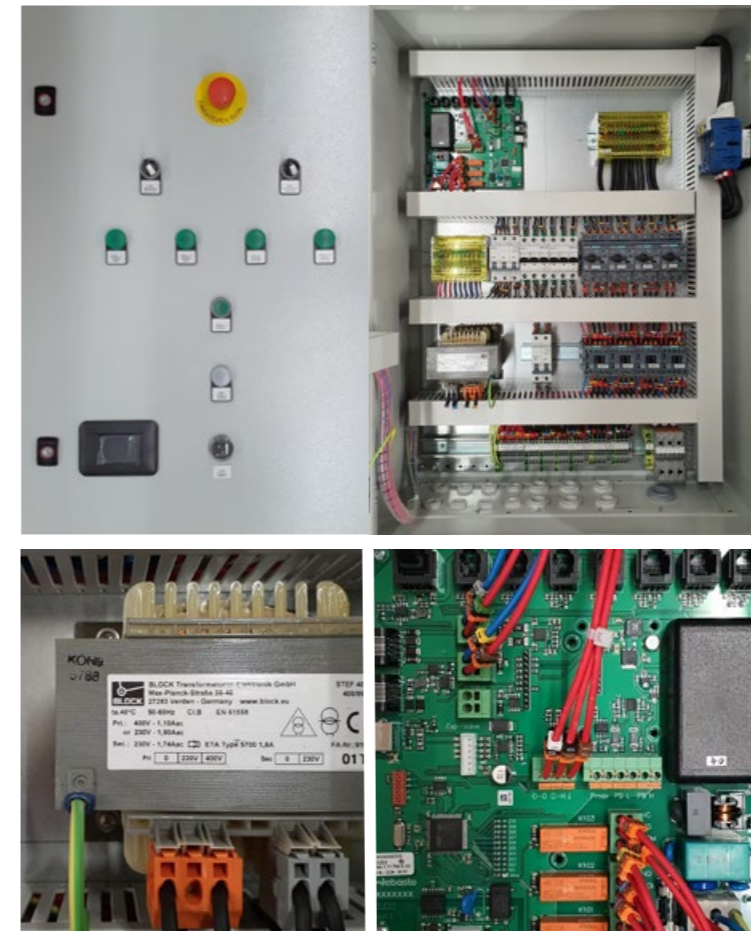

BlueCool V-PRO Series Electronic Box

Type	Pump Control Box	Remote Connection Box	Master Control Box		
			1 – 2	3 – 4	5 – 6
Number of V-PRO modules	1 – 6	1 – 6	1 – 2	3 – 4	5 – 6
Box					
ABS plastic	■	–	–	–	–
Steel, painted	–	■	■	■	■
Wall mounted box	–	■	■	■	■
Door locking mechanism in open position	–	–	■	■	■
Features Electronic Box					
V-PRO Chiller electronic card	–	■	■	■	■
MyTouch display integrated at the front	–	■	■	■	■
Pilot lamp for pumps	–	–	■	■	■
Relay for chilled water and sea water pump	■	■	■	■	■
ON/OFF Button	–	■	■	■	■
Power ON lamp	–	■	■	■	■
Only one power supply needed for entire unit	–	–	■	■	■
Emergency Stop	–	–	■	■	■
Chilled water pump: redundancy selector for two pumps	–	–	■	■	■
Sea water pump: redundancy selector for two pumps	–	–	■	■	■
Motor protection switch for pumps	–	–	■	■	■
Main isolator switch	–	–	■	■	■
Ability to connect system to 400 V 3-ph power supply without neutral wire	–	–	■	■	■
Power supply indicator 400 V	–	–	■	■	■
Power supply indicator 230 V from transformer	–	–	■	■	■
Circuit breaker V-Pro modules	–	–	■	■	■
Circuit breaker pumps	–	–	■	■	■
Circuit breaker for chiller electronic card	–	–	■	■	■
Halogen free cables	–	■	■	■	■
Rail-Mount Terminal Blocks	–	■	■	■	■
Suitable to connect BlueCool CAN bus module	–	■	■	■	■

BlueCool V-PRO Series Electronic Box

NEW

Type	V-PRO Control Boxes	Order number
V-PRO Pump Control Box	External pump Control box for easy remote connection via network cable	2510581A
V-PRO Remote Connection Box	Connect and Control your V-PRO system from any place on board. With additional MyTouch display, PCB with 3 relay output, relays for chilled and sea water pump, USB connector.	2510699A
V-PRO Master Control Box	Central power supply with power indicator, central ON/OFF and emergency stop, circuit breakers for V-PRO units, PCB and pump selector switch, relays for two sea water and chilled water pumps	
V-PRO Master Control Box Mono-Twin	For 1 or 2 V-PRO units	2113266A
V-PRO Master Control Box Triple Quattro	For 3 – 4 V-PRO units	2113267A
V-PRO Master Control Box Quinta-Hexa	For 5 – 6 V-PRO units	2113268A



BlueCool V-PRO Series Manifolds

Manifold Single Unit		Order number
	Manifold V-PRO 1-100* Manifold for single unit V-PRO60 M or V-PRO 90 M - 4 Connector V-PRO 1 1/4" - 4 Ball valves 1 1/4" - 4 Pipe (65 – 385 mm) - 4 Pipe Bend Chilled water and sea water circuit 1 1/4" - 4 Connector Chilled water and sea water circuit 1 1/4"	2510456A
	Manifold V-PRO 1-200* Manifold for single unit V-PRO130 M or V-PRO 180 M - 4 Connector V-PRO 1 1/4" - 4 Ball valves 2" - 4 Pipe (79 – 399 mm) - 4 Pipe Bend chilled water and sea water circuit 2" - 4 Connector Chilled water and sea water circuit 2"	2510450A
Manifold Two Units		Order number
	Manifold V-PRO 2-110* Manifold for 2 units – combination of one unit V-PRO 60M or V-PRO90 M with one unit V-PRO 60 M or V-PRO 90M - 8 Connector V-PRO 1 1/4" - 8 Ball valves 1 1/4" - 4 Pipe (344 mm) - 4 Pipe (65 – 385 mm) - 4 Pipe Bend Chilled water and sea water circuit 1 1/4" - 4 Connector Chilled water and sea water circuit 2"	2510472A
	Manifold V-PRO 2-210* Manifold for 2 units – combination of one unit V-PRO 60M or V-PRO90 M with one unit V-PRO130 M or V-PRO 180 M - 8 Connector V-PRO 1 1/4" - 4 ball valves 1 1/4" - 4 Ball valves 2" - 4 Pipe 2" (79 – 399 mm) - 4 Pipe 1 1/4" (331 mm) - 4 Pipe Bend Chilled water and sea water circuit 1 1/4" - 4 Connector Chilled water and sea water circuit 2"	2510478A
	Manifold V-PRO 2-220* Manifold for 2 units – combination of one unit V-PRO 130M or V-PRO180 M with one unit V-PRO130 M or V-PRO 180 M - 8 Connector V-PRO 1 1/4" - 8 Ball valves 2" - 4 Pipe 2" (79 – 399 mm) - 4 Pipe 2" (296 mm) - 4 Pipe Bend Chilled water and sea water circuit 2" - 4 Connector Chilled water and sea water circuit 2"	2510466A
Manifold Three Units		Order number
	Manifold V-PRO 3-221* Manifold for 3 units – combination of one unit V-PRO 130M or V-PRO180 M with two units V-PRO130 M or V-PRO 180 M - 12 Connector V-PRO 1 1/4" - 4 Ball valves 1 1/4" - 8 Ball valves 2" - 4 Pipe 1 1/4" (331 mm) - 4 Pipe 2" (377 mm) - 4 Pipe 2 1/2" (90 – 410 mm) - 4 T-piece 2" - 4 T-piece 2 1/2" - 4 Pipe Bend Chilled water and sea water circuit 1 1/4" - 4 Connector Chilled water and sea water circuit 2"	2510484A
	Manifold V-PRO 3-222* Manifold for 3 units – combination of three units V-PRO130 M or V-PRO 180 M - 12 Connector V-PRO 1 1/4" - 12 Ball valves 2" - 4 Pipe 2" (270 mm) - 4 Pipe 2" (296 mm) - 4 Pipe 2" (377 mm) - 4 Pipe 2 1/2" (90 – 410 mm) - 4 T-piece 2" - 4 T-piece 2 1/2" - 4 Pipe Bend Chilled water and sea water circuit 2" - 4 Connector Chilled water and sea water circuit 2"	2510490A

* Please use adhesives for thermoplastic piping systems according to EN 14814 or similar. Adhesives are not included in scope of delivery.

BlueCool V-PRO Series Rack

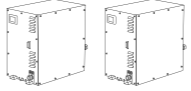

Number of units	Rack system V-PRO in line	Item description	Order number
2		Rack 2 x V-PRO 2-1 in line	2510525A
3		Rack 3 x V-PRO 3-1 in line	2510526A

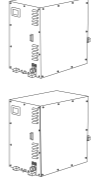
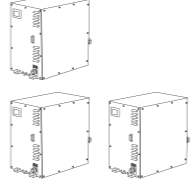
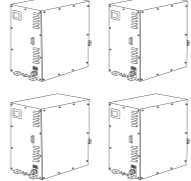
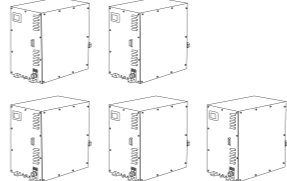
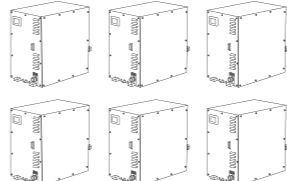
Number of units	Rack system V-PRO on top	Item description	Order number
2		Rack 2 x V-PRO 1-2 on top	2510527A
3		Rack 4 x V-PRO 2-2 on top	2510528A
4		Rack 4 x V-PRO 2-2 on top	2510528A
5		Rack 6 x V-PRO 3-2 on top	2510529A
6		Rack 6 x V-PRO 3-2 on top	2510529A

BlueCool F-Series Fresh Air Makeup Units

Fresh air systems

BlueCool F-Series fresh air systems are the ideal complement to your central chiller system. Fresh outside air is filtered and cooled before it is brought into the cabin at the ideal comfort temperature. Stale air is extracted and transported to the outside. A sophisticated control concept of cooling and heating ensures the ideal condition of temperature and humidity.



The BlueCool F-2000 Fresh Air can also be used as a large, silent air handler in combination with the Cabin Control Kit A-Series.

Higher air flow

3 variants for 500 up to 2,000 m³/h fresh air and extract air. All units are operating with high efficiency EC-blower with high back pressure resistance.

High cooling capacity

Increased cooling capacity by up to 75 % compared to previous fresh air system. Cooling capacity with up to 84 kBTU/h. Ideal solution for larger yachts.

Compact design

Standardized and compact design.

High efficiency air filters

Equipped with standard air filter of category G3. High grade F7 filter available for easy exchange.

Improved climate control logic

Constant supply air temperatures with integrated solenoid proportional valve and up to 20 kBTU/h staged electrical heating. Acoustics - optimized components for use in particularly noise-critical applications.

BlueCool F-Series Fresh Air Systems

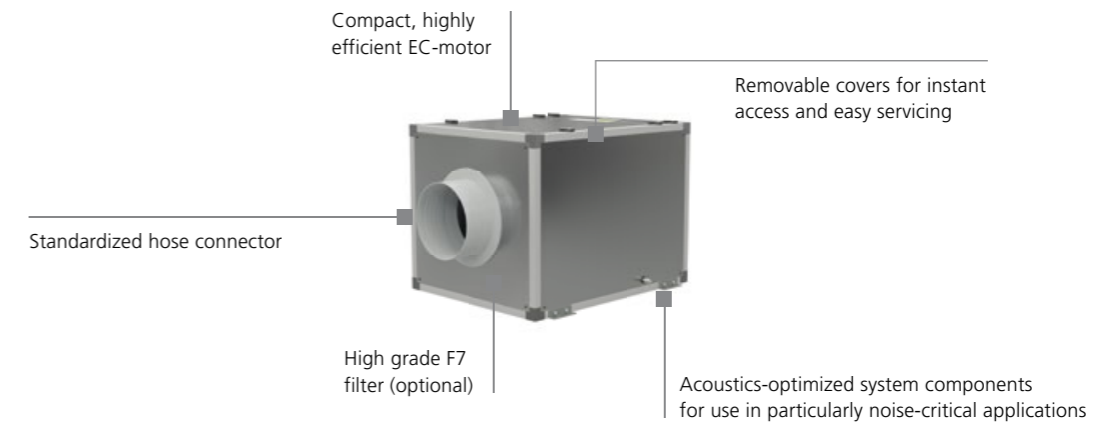

Control elements for BlueCool F-Series (FreshAir)

Please select the control elements for the core unit separately:

Control Box F-Series F500-F2000

[See page 142](#)

Technical data

	BlueCool Fresh Air and Extract					
	F500 FreshAir	F1000 FreshAir	F2000 FreshAir	F500 Extract	F1000 Extract	F2000 Extract
Part No.	2510265A	2510266A	2510267A	2510268A	2510269A	2510270A
Air flow (300 Pa) (m ³ /h)	500	1,000	2000	500	1,000	2,000
Air flow (300 Pa) (cfm)	294	588	1,177	294	588	1,177
Cooling capacity (kBTU/h)	21	42	84	-	-	-
Cooling capacity (kW)	6.0	12.0	25.0	-	-	-
Heating capacity 'chilled' water (kBTU/h)	21	42	84	-	-	-
Heating capacity 'chilled' water (kW)	6.0	12.0	25.0	-	-	-
Heating capacity electric (kBTU/h)	5.0	10.0	20.0	-	-	-
Heating capacity electric (kW)	1.5	3	6	-	-	-
Heating capacity total (kBTU/h)	26	52	104	-	-	-
Heating capacity total (kW)	7.5	15	31	-	-	-
Voltage (V)	230	230	230	230	230	230
Frequency (Hz)	50/60	50/60	50/60	50/60	50/60	50/60
Current draw Cooling (A) 50 + 60 Hz max.	7.5	14.9	29.8	-	-	-
Current draw Heating (A) 50 + 60 Hz max. ('chilled' water + electric)	7.5	14.9	29.8	-	-	-
Current Blower (A)	0.8	1.4	2.7	0.8	1.4	2.7
Power consumption heating (kW)	1.7	3.3	6.6	-	-	-
Power consumption cooling (kW)	1.7	3.3	6.6	-	-	-
Chilled Water connection (mm)	DN20	DN25	DN32	-	-	-
Chilled Water connection (Inch)	3/4	1	1 1/4	-	-	-
Minimum Chilled Water flow (l/min.)	18	37	73	-	-	-
Dimensions L x H x W (mm)	720 x 400 x 500	760 x 550 x 650	930 x 700 x 750	320 x 320 x 320	450 x 450 x 450	600 x 600 x 600
Dimensions Lx H x W (inch)	28.3 x 15.7 x 19.7	29.9 x 21.7 x 25.6	36.6 x 27.6 x 29.5	12.6 x 12.6 x 12.6	17.7 x 17.7 x 17.7	23.6 x 23.6 x 23.6
Discharge connection diameter (mm)	150	2x 150	315	150	200	315
Discharge connection diameter (inch)	6	7.5	12.5	6	7.5	12.5
Suction connection diameter (mm)	150	200	315	150	200	315
Suction connection diameter (inch)	6	8	12.5	6	8	12.5
Weight Unit (kg)	42	65	110	25	35	60
Weight Electrical Box (kg)	7	7	7	-	-	-

BlueCool A-Series

Instant Drain Systems

BlueCool A-Series

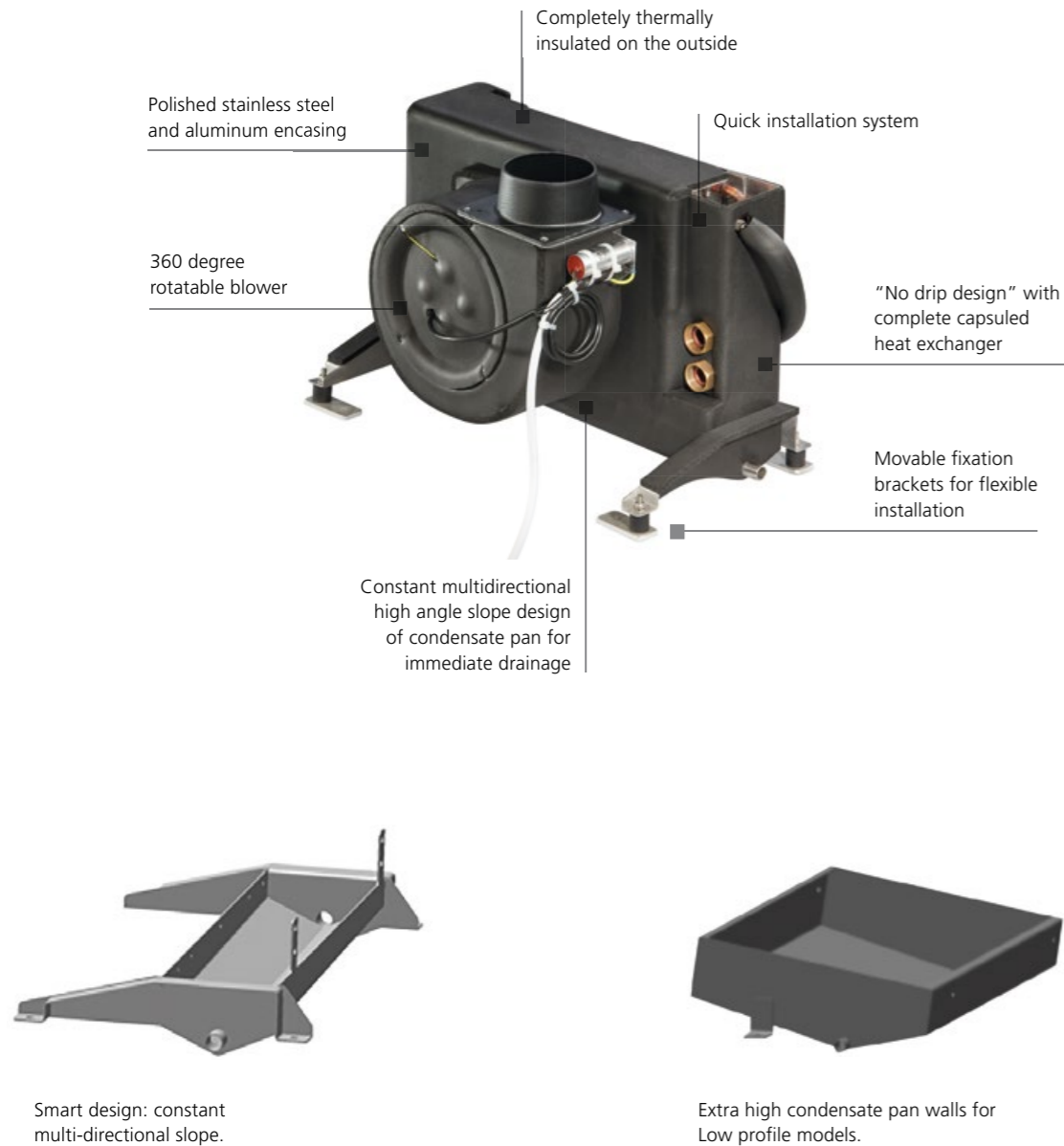

- Exclusive Instant Drain condensate management system
- Constant multidirectional high angle slope design of condensate pan for immediate drainage
- Anti splash condensate management
- "No drip design" with complete capsuled heat exchanger through additional side plates and improved insulation

Air Handlers: BlueCool A-Series

Modular System to Fit Any Demand

Webasto offers a range of air handlers to fit any demand on capacity or space limitations. The modular concept makes the A-Series adaptable to individual requirements and the exclusive Webasto Instant Drain condensate management system ensures immediate drainage. Accessories like the Ultimate Cabin Control, MyTouch display, electric heat modules or flow control valves can fine-tune your applications.



BlueCool A-Series

One or more air handler(s) in each cabin are fitted to generate the required cooling capacities individually in each room. Webasto provides a completely new designed air handler portfolio in 3 different layouts with a performance range from 4,000 – 36,000 BTU/h to suit all sizes and space requirements of your boat.

EHM – Electric Heat Module

The electric heat module EHM ensures cabin heating independent from chiller operation. It is easily installed in-line into the air duct of the A-Series air handlers and provides 600 – 1,800 W capacity to enable heating in selective cabins while chiller is in cooling mode.

Flow Control Valve

The flow control valve allows the chilled water to bypass the heat exchanger of the A-Series when needed. The comfort on boards is increased while directing the chilled water only to those cabins with cooling/heating demand. Continuous blower operation is possible to reduce noise variations in cabins.

Cabin Controls

Choose between Ultimate Cabin Control with Ultra silent blower operation and master-slave integration or Standard Cabin Control. Both available as complete kits with all necessary components.

BlueCool A-Series

Modular Air Handler Systems



Model	Compact						
	A4 Compact	A6 Compact	A9 Compact	A12 Compact	A18 Compact	A24 Compact	A36 Compact
Order numbers	WBCL1209009A	WBCL1209010A	WBCL1209011A	WBCL1209012A	WBCL1209013A	WBCL1209014A	WBCL1209015A
Capacity (BTU/h) **	4,000	6,000	9,000	12,000	18,000	24,000	36,000
Capacity (kW) **	1.2	1.9	2.8	3.6	5.6	7.2	10.7
Voltage (V)	230 (-15%/+10%)	230 (-15%/+10%)	230 (-15%/+10%)	230 (-15%/+10%)	230 (-15%/+10%)	230 (-15%/+10%)	230 (-15%/+10%)
Frequency (Hz)	50/60 (+-5%)	50/60 (+-5%)	50/60 (+-5%)	50/60 (+-5%)	50/60 (+-5%)	50/60 (+-5%)	50/60 (+-5%)
Air flow (m³/h) *	230	380	420	560	750	1120	1550
Air flow (cfm) *	135	224	247	330	441	659	912
Ø Blower connection (mm)	100 (round)	125 (round)	125 (round)	150 (oval)	150 (oval)	2 x 150 (oval)	2 x 150 (oval)
Ø Blower connection (inch)	4 (round)	5 (round)	5 (round)	6 (oval)	6 (oval)	2 x 6 (oval)	2 x 6 (oval)
Weight (kg)	6	7	9	10	12	16	21
Weight (lbs)	13.2	15.4	18.7	22	26.5	35.3	46.3
Current draw running (A)	0.6	0.5	0.6	0.7	1	1.3	2.1
Ø Chilled water connection	3/4"	3/4"	3/4"	3/4"	3/4"	3/4"	3/4"
Dimensions H x W x L (mm)	287 x 249 x 381	287 x 280 x 411	312 x 291 x 456	312 x 279 x 491	362 x 281 x 581	362 x 301 x 636	487 x 302 x 701
Dimensions H x W x L (inch)	11.3 x 9.8 x 15	11.3 x 11 x 16.2	12.3 x 11.5 x 18	12.3 x 11 x 19.3	14.3 x 11.1 x 22.9	14.3 x 11.9 x 25	19.2 x 11.9 x 27.6
Dimensions with valve H x W x L (mm)	287 x 249 x 381	287 x 280 x 411	312 x 291 x 456	312 x 279 x 491	362 x 281 x 581	362 x 301 x 636	487 x 302 x 701
Dimensions with valve H x W x L (inch)	11.3 x 9.8 x 15	11.3 x 11 x 16.2	12.3 x 11.5 x 18	12.3 x 11 x 19.3	14.3 x 11.1 x 22.9	14.3 x 11.9 x 25	19.2 x 11.9 x 27.6
Minimum chilled water flow (l/min.)	4	7	10	9	13	21	31
Number of blowers	1	1	1	1	1	2	2
Max. ambient temperature (°C)	50	50	50	50	50	50	50
Pressure loss chilled water (bar)	0.07	0.12	0.15	0.14	0.16	0.13	0.34
Number of condensate drains	2	2	2	2	2	2	2
Ø Condensate drain (mm)	16	16	16	16	16	16	16

* With 2 m of air duct, one 90° bend, air outlet grille at 230 V, 50 Hz

** Intake air of 32°C/47% rh, water inlet temperature of 5°C and at 230 V, 50 Hz

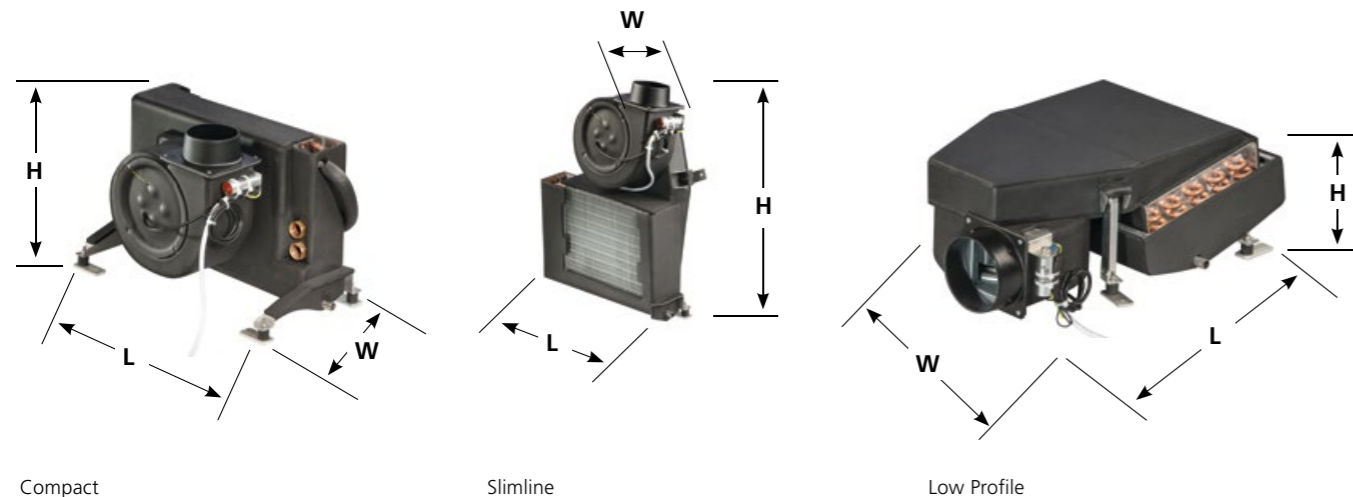

Compact

Slimline

Low Profile

Model	Slimline				Low Profile			
	A6 Slimline	A9 Slimline	A12 Slimline	A18 Slimline	A6 Low Profile	A9 Low Profile	A12 Low Profile	A18 Low Profile
Order numbers	WBCL1209001A	WBCL1209002A	WBCL1209003A	WBCL1209004A	WBCL1209005A	WBCL1209006A	WBCL1209007A	WBCL1209008A
Capacity (BTU/h) **	6,000	9,000	12,000	18,000	6,000	9,000	12,000	18,000
Capacity (kW) **	1.9	2.8	3.6	5.6	1.9	2.8	3.6	5.6
Voltage (V)	230 (-15%/+10%)	230 (-15%/+10%)	230 (-15%/+10%)	230 (-15%/+10%)	230 (-15%/+10%)	230 (-15%/+10%)	230 (-15%/+10%)	230 (-15%/+10%)
Frequency (Hz)	50/60 (+-5%)	50/60 (+-5%)	50/60 (+-5%)	50/60 (+-5%)	50/60 (+-5%)	50/60 (+-5%)	50/60 (+-5%)	50/60 (+-5%)
Air flow (m³/h) *	380	420	560	750	380	420	560	750
Air flow (cfm) *	224	247	330	441	224	247	330	441
Ø Blower connection (mm)	125 (round)	125 (round)	150 (oval)	150 (oval)	125 (round)	125 (round)	150 (oval)	150 (oval)
Ø Blower connection (inch)	5 (round)	5 (round)	6 (oval)	6 (oval)	5 (round)	5 (round)	6 (oval)	6 (oval)
Weight (kg)	7	9	10	12	10	11	13	16
Weight (lbs)	15.4	19.8	22	26.5	21.6	24.3	28.7	35.3
Current draw running (A)	0.5	0.6	0.7	1.1	0.5	0.6	0.7	1.1
Ø Chilled water connection	3/4"	3/4"	3/4"	3/4"	3/4"	3/4"	3/4"	3/4"
Dimensions H x W x L (mm)	588 x 217 x 411	611 x 217 x 456	619 x 217 x 494	666 x 218 x 581	205 x 437 x 582	205 x 482 x 606	205 x 516 x 614	205 x 599 x 661
Dimensions H x W x L (inch)	23.1 x 8.5 x 16.2	24.1 x 8.5 x 18	24.4 x 8.5 x 19.4	26.2 x 8.6 x 22.9	8.1 x 17.2 x 22.9	8.1 x 19 x 23.9	8.1 x 20.3 x 24.2	8.1 x 23.6 x 26
Dimensions with valve H x W x L (mm)	588 x 217 x 479	611 x 217 x 524	619 x 217 x 559	666 x 218 x 649	205 x 487 x 582	205 x 532 x 606	205 x 567 x 614	230 x 657 x 661
Dimensions with valve H x W x L (inch)	23.1 x 8.5 x 18.9	24.1 x 8.5 x 20.6	24.4 x 8.5 x 22	26.2 x 8.6 x 25.6	8.1 x 19.2 x 22.9	8.1 x 20.9 x 23.9	8.1 x 22.3 x 24.2	9.1 x 25.9 x 26
Minimum chilled water flow (l/min.)	7	10	9	13	7	10	9	13
Number of blowers	1	1	1	1	1	1	1	1
Max. ambient temperature (°C)	50	50	50	50	50	50	50	50
Pressure loss chilled water (bar)	0.12	0.15	0.14	0.16	0.12	0.15	0.14	0.16
Number of condensate drains	2	2	2	2	2	2	2	2
Ø Condensate drain (mm)	16	16	16	16	16	16	16	16

The MyTouch display is included in the A-Series Cabin Control Kit



BlueCool MyTouch

- Three possible shapes to cope with any installation demand: Compact, Slimline and Low profile
- Modular system with various options
- Innovative Webasto Instant Drain system for smart management of condensate
- High quality stainless steel condensate tray
- High performance with high cooling capacity and high air flow
- Super Silent with
 - flexible vibration isolation mounts
 - larger ducts to reduce noise from air speed
- Oversized heat exchanger tested under tropical conditions
- Rotatable blower

BlueCool A-Series Electric Heat Module

Type	EHM600W -100 mm -230 V -50/60 Hz	EHM900W -125 mm -230 V -50/60 Hz	EHM1200W -150 mm -230 V -50/60 Hz	EHM1800W -150 mm -230 V -50/60 Hz
Order numbers	WBCL1209100B	WBCL1209101B	WBCL1209102B	WBCL1209103B
Capacity (W)	600	900	1,200	1,800
Dimensions (L x W x H) (mm)	370 x 100 x 170	370 x 125 x 195	370 x 150 x 220	370 x 150 x 220
Dimensions (L x W x H) (inch)	14.6 x 3.9 x 6.7	14.6 x 4.9 x 7.7	14.6 x 5.9 x 8.7	14.6 x 5.9 x 8.7
Ø Hose connection (mm)	100	125	150	150
Ø Hose connection (inch)	4	5	6	6
Voltage (V)	230 (-15%/+10%)	230 (-15%/+10%)	230 (-15%/+10%)	230 (-15%/+10%)
Frequency (Hz)	50/60 (+5%)	50/60 (+5%)	50/60 (+5%)	50/60 (+5%)
Current draw running (A)	3	4	5	8
Max. supply air temperature (°C)	40	40	40	40
Cut off temperature safety switch (°C)	60	60	60	60
Pressure loss air (Pa)	60	60	60	60
Min. air flow (m³/h) to ensure full heat output	60	80	120	180
Weight (kg)	2.2	2.6	2.8	3

Compatibility	A4 Compact	A6 Compact, Slimline, Low Profile	A9 Compact, Slimline, Low Profile	A12 Compact, Slimline, Low Profile	A18 Compact, Slimline, Low Profile	A24 Compact	A36 Compact
EHM600W	■	□	□	□	□	□	□
EHM900W	-	■	■	-	□	-	□
EHM1200W	-	-	-	■	■	■	■
EHM1800W	-	-	-	-	■	-	■

■ Standard application, check on minimum airflow in technical data. □ Only for secondary ducts with smaller diameter, check on minimum airflow in technical data.

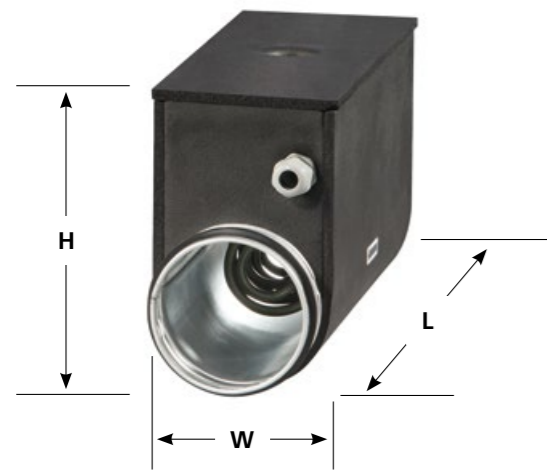

EHM – Electric heat module

- Electric heat modules ensure cabin heating independent of chiller operation
- They are easily installed in-line into air duct of the A-Series air handlers
- EHM is directly connected to A-Series electronics so no separate controls are needed
- EHM further increase the comfort on board by:
 - enabling heating in selective cabins while chiller is in cooling mode
 - enable heating while chiller is switched off
 - increasing the heat output of air handlers if extra high heat demand is needed
- EHM can easily be retrofitted to existing A-Series
- EHM is preinsulated to prevent condensation on the outside. It also comes with 2 stainless steel mounting brackets for wall mounting
- When using EHM a flow control valve also needs to be fitted

BlueCool A-Series Flow Control Valve



Valve with motor actuator	Kit Motor Valve Slimline / Low profile A-Series with 90° elbow	Kit Motor Valve Compact A-Series
Order numbers	WBCL151004B	WBCL151003B

Valve with thermal actuator*	Kit Therm Valve Slimline / Low profile A-Series with 90° elbow	Kit Therm Valve Compact A-Series
Order numbers	2510181A	2510182A

* Valves with thermal actuator are suitable for A-Series model from A4 up to A18. Due to their longer activation time they are not suitable to be operated in permanent blower mode.



Flow control valve for Slimline and Low Profile



Flow control valve for Compact

- The flow control valve acts as a 3/2-way valve allowing the chilled water to bypass the heat exchanger of the A-Series when needed
- Easy screw connection to all A-Series units, no soldering needed
- Easy electrical connection to A-Series electronics
- 90° elbows in the Slimline/Low profile kit enable an extra flat installation
- The flow control further increases the comfort on board by:
 - directing the chilled water only to those cabins with cooling/heating demand
 - prevent inadvertent heating when air handler is switched off
 - no chimney effect
 - prevents condensate build-up and thus mold on heat exchangers of air handlers which are switched off
 - continuous blower operation is possible thus reducing noise variations in cabins
- Valve needs to be fitted if EHM is installed to prevent simultaneous heating and cooling

BlueCool A-Series

Ultimate Cabin Control – Ultra Silent Blower Operation

Ultimate Cabin Control – the 2 in 1 solution to provide very silent blower operation and to control a network of BlueCool A-Series air handlers.

1. High performance Silencer

Standard Cabin Control: Phase-cutting principle

The standard Cabin Control kit uses the phase-cutting principle with triacs to control the blower motor speed. This chops the incoming sine wave and thus creates electrical bursts which hit the blower motor and cause mechanical noises such as humming and vibration, particularly in low blower speed levels.

Ultimate Cabin Control: PWM for blower speed control

The Ultimate Cabin Control uses pulse width modulation (PWM) to operate the AC-driven blower motor. With such fast pulses in a frequency of 10 to 16 kHz the amperage reaching the blower motor is very smooth and thus does not cause any humming noise or vibrations in low blower speeds. It also allows to run the blower in very low speed levels to marginalize air flow noise. The Ultimate Cabin Control can be used with all BlueCool A-Series air handlers.

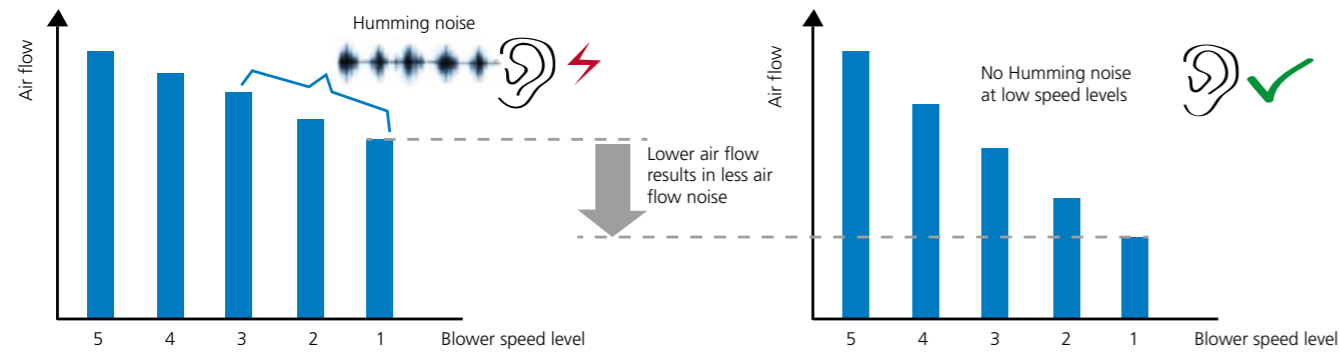

2. Control of a network of Air Handlers via “Master-Slave integration”

One Ultimate Cabin Control box is already capable to control several air handlers with a max. total amperage of 3.15 A. For larger cabins requiring more air handlers, one single BlueCool My Touch user interface can control up to 15 Ultimate Cabin Control devices networked together in a “Master-Slave integration”.



Ultimate Cabin Control

- Ultra silent blower operation due to PWM control
- Innovative Master-Slave integration allows to connect multiple units together
- Individually adjustable 5-step fan speed
- Compatible to all BlueCool A-Series air handlers
- Meets the highest EMC requirements of IEC/EN 60945
- One MyTouch display can operate all connected cabin controls

BlueCool A-Series

Cabin Control Kits



	Cabin Controls for BlueCool A-Series	Order number
	Ultimate Cabin Control Kit Kit includes: Electrical box with controller card, MyTouch display with Webasto cover plate, display cable 5 m, air temperature sensor 3 m. Max. switching current 3.15 A. Will be the “Master” unit in a Master-Slave configuration.	2510197A
	Ultimate Cabin Control Includes: Electrical box with controller card. Max. switching current 3.15 A. Shall be configured as “Slave” unit in a Master-Slave configuration.	2510198A
	Cabin Control Kit A-Series Includes: Electrical box with controller card, MyTouch display with Webasto cover plate, display cable 5 m, air temperature sensor 3 m. Max. switching current 2 x 3.15 A.	WBCL151000C

Cabin Control for BlueCool A-Series

- Complete kits available including all necessary components
- Pre-configured for all BlueCool A-Series
- Integrates Webasto’s BlueCool Expert Tool diagnosis and set up tool
- MyTouch as standard user interface with clear text display
- Optional CAN-Bus for optimized adaptations to boat systems



Accessories for Cooling Systems

BlueCool Connect	136
Air-Conditioning Control Elements	140
Self Priming Pumps	144
Pumps	145
Blowers Modules and Air Flow Regulators	148
Air System	149
Water System	155
Accessories for S-, V-, and C-Series	160
BlueCool Expert Tool	161

BlueCool Connect

One Device Gets All Connections Done

Whenever there is a demand for remote operation and servicing the BlueCool Connect will be the best choice. Checking onboard temperatures and settings, modifying system parameters or collecting a status report and sending it onshore remotely. The BlueCool Connect offers the same functions as if you would be on the spot, but with the comfort of doing it from anywhere in the world with many internet devices available.

- 1. Toggle for Units/Groups** Visible when one or more groups have been created
- 2. Expand/Collapse controls** Opens /closes cabin settings displays
- 3. Timer** Setting the Timer
- 4. Blower Control** Set blower speed or Auto setting
- 5. Blower Setting** See current blower setting
- 6. Temperature Control** Set cabin temperature
- 7. Temperature Setting** See temperature set value
- 8. Actual Cabin Temperature** See actual cabin temperature
- 9. On/Off for Units/Groups** One click operation of multiple BlueCool Units

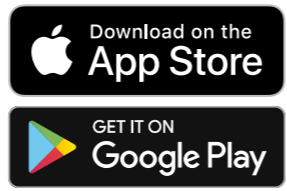
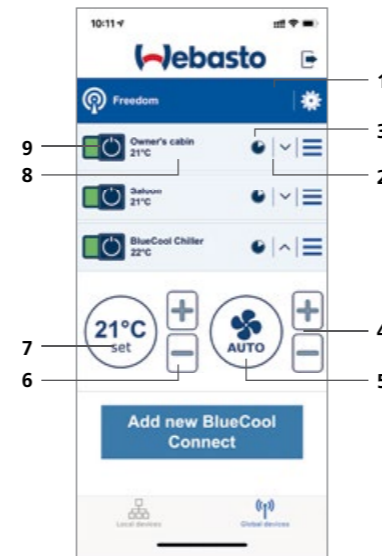

- Key Benefits at a Glance:**
- Accessible from anywhere in the world
 - Use any device like Smartphone, Tablet or Computer
 - Central monitoring via your Multi-Functional-Display e.g. Garmin, Raymarine, Simrad, Lowrance and B & G displays with HTML5 functionality
 - Remote condition monitoring system
 - NMEA 2000 interface
 - Use of handheld, portable equipment to monitor A/C equipment periodically
 - Collect data and send it onshore remotely

BlueCool Connect

One Device Gets All Connections Done

NEW

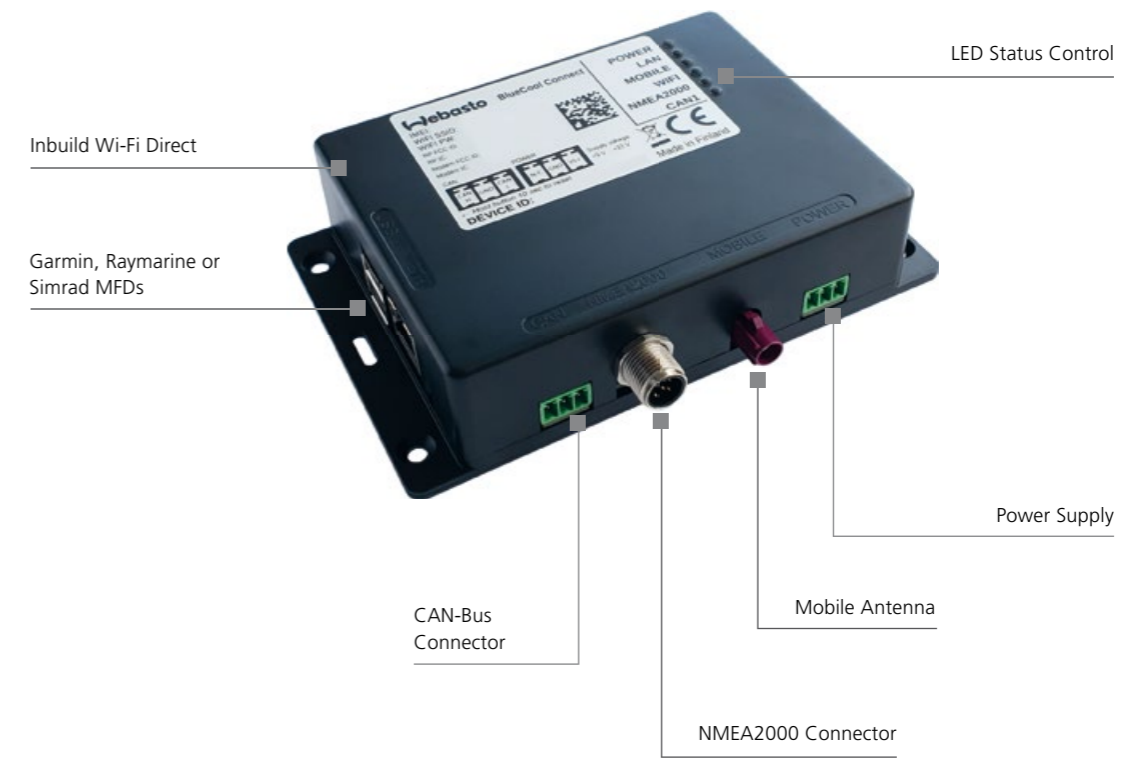

Technical data

	BlueCool Connect
Operating voltage range (V)	9 – 33
Power consumption (W)	13.5
Input	CAN (SAE J1939)
Output	Wi-Fi Direct Mobile (Telephone) Network NMEA 2000 LAN – Ethernet
Dimensions (L x B x H) (mm)	140 x 104.9 x 33.8
Weight (kg)	0.34
Operating Temperature (°C)	-40 to +80

BlueCool Connect

One Device Gets All Connections Done

One device gets all connections done. Mobile network, Multifunctional Displays, NMEA2000, WiFi. BlueCool Connect turns connectivity into a child's play.

Easy operation of all BlueCool Series via smart phone:

- Easy access via BlueCool Connect app
- Inbuilt SIM automatically connects to mobile network in EU, USA and Canada
- Additional Ethernet connector to hook up into boats internet connection
- All connected A/C units can be accessed and controlled individually
- Multiple users can be set up to access the A/C systems
- Works even locally WiFi-based when no mobile network is available
- Access all your BlueCool devices with your smart phone from anywhere in the world

Integration into all Garmin, Raymarine, Simrad, Lowrance and B&G displays with HTML5 functionality:

- Ethernet connection for easy MFD integration
- Using your existing MFD to control all A/C systems
- Integrated BlueCool webserver displaying Webasto screens
- Single operation via MFD, smart phone, MyTouch display or everything connected in parallel

Remote control center for all operations and diagnosis:

- Worldwide access to all connected A/C units via tablet/notebook
- Complete BlueCool Expert Tool functionality via remote connection
- Remote software updates
- Easy parameters read out and changing
- Remote troubleshooting
- Back-up and upload of application-specific presets
- Save individual presets or load standard presets
- Real-time system monitoring
- Access to data logs
- All relevant data are stored for easy review
- Check function of all components and connected accessories

NMEA2000 interface allows integration into Multi Functional Displays:

- Key commands allow to control and monitor the A/C system via the NMEA2000 bus

BlueCool Connect

One Device Gets All Connections Done

NEW

	BlueCool Connect Kit	Order number
	BlueCool Connect Kit including BlueCool Connect control box, Multiband Antenna, plugs for individual 12 V power Supply and CAN connection	25102198
Accessories		Order number
	Power Supply BlueCool Connect 115 – 230 V	2510214A

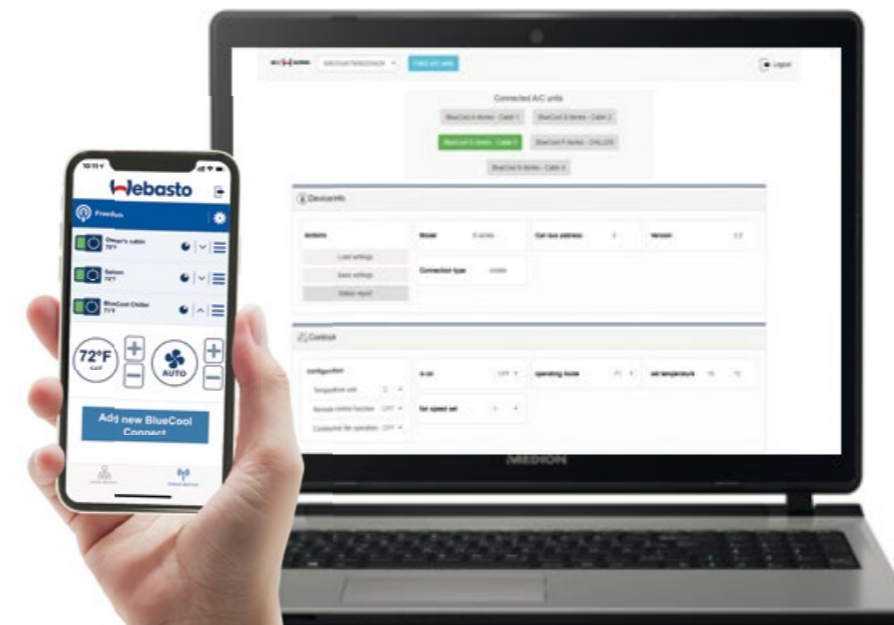
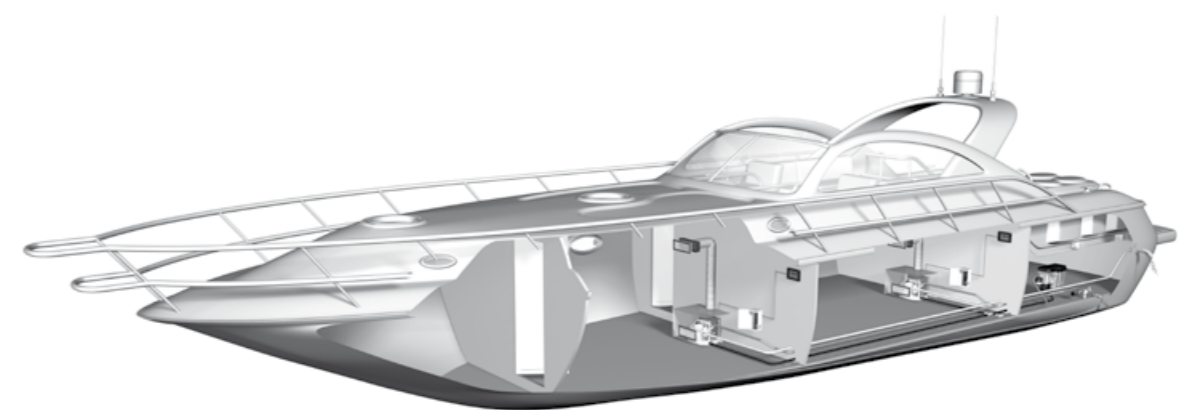

BlueCool Connect for all BlueCool Series

- Easy operation of all BlueCool Series via smart phone
- Integration into your MFD
- Remote control center for all operations and diagnosis.

Air Conditioning Control Elements

BlueCool MyTouch

The BlueCool MyTouch display is the standard display for all BlueCool A/C Series and is part of a complete electronic control system including the A/C controller card and connecting cables/sensors.



3 different software designs and Webasto cover plate

- Standard display for all BlueCool A/C units
- Full color, high resolution, interactive touch display
- Individual customizable Multi Design Touch Display with 3 different user designs
- Intuitive icons and menus
- 3 different menu levels with
- Easy intuitive operation for end customer
- Advanced settings for crew member
- Complete parameter access for technician with clear text message

Customizable to many cover plate systems like

- Vimar Eikon
- Vimar Eikon EVO
- Vimar Plana
- Btcino Axolute

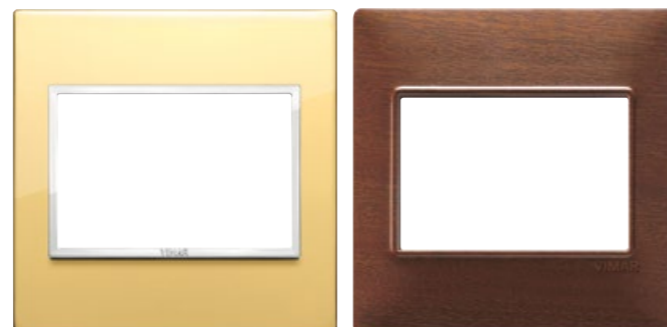
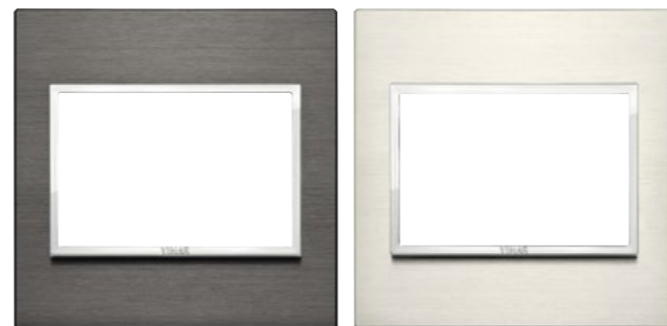

Air Conditioning Control Elements

BlueCool MyTouch

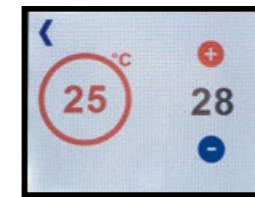

Easy temperature selection with actual cabin temperature (left) and adjustable target temperature (right)

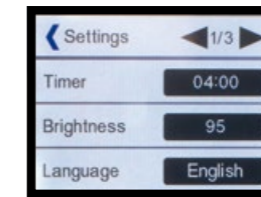

Easy navigation through display settings menu with clear text in 10 languages

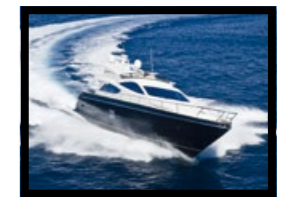

Individual picture can be uploaded to be used as Stand-by screen

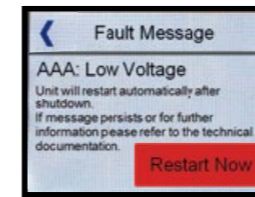

Failure codes show up in clear text

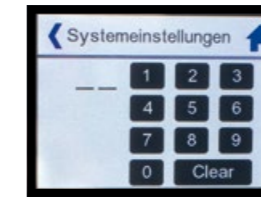



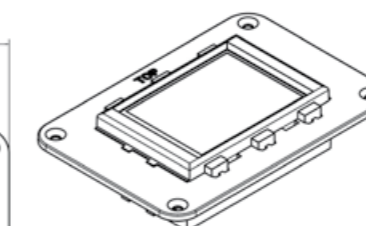
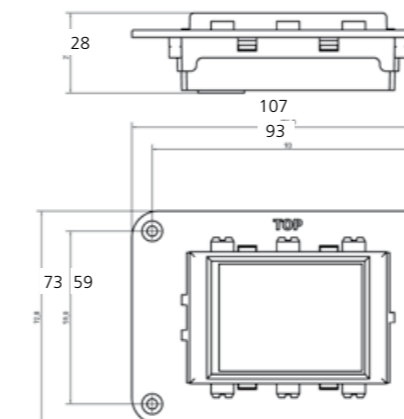
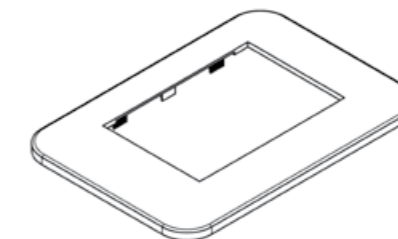
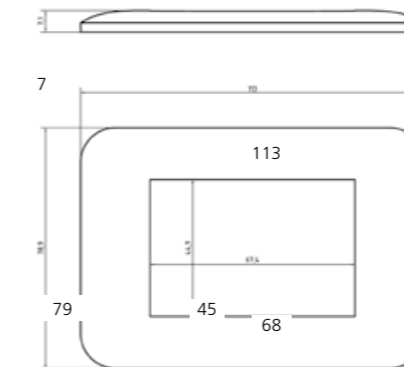

System settings menu is code protected to prevent unwanted changes





Air Conditioning Control Elements

Electronic Controls

		BlueCool S-Series	BlueCool C-, V-, P-Series	BlueCool A-Series	BlueCool F-Series	Order number
	MyTouch Display	✓	●			WBCL151002C
	Cabin Control Kit A-Series Includes: electrical box with controller card, MyTouch display with Webasto cover plate, display cable 5 m, remote air temperature sensor 3 m, max. switching current: 2 x 3.15 A			●*	●***	WBCL151000C
	Ultimate Cabin Control Kit Includes: electrical box with controller card, MyTouch display with Webasto cover plate, display cable 5 m, remote air temperature sensor 3 m, max. switching current: 3.15 A Will be the "Master" unit in a Master-Slave configuration			●*		2510197A
	Ultimate Cabin Control Includes: Electrical box with controller card, max. switching current: 3.15 A Shall be configured as "Slave" unit in a Master-Slave configuration			●		2510198A
	Control Box F-Series F500-F2000 Kit includes: Electrical box with controller card, MyTouch display with Webasto cover plate, display cable 5 m				●	2510288A
	Display cable MyTouch 5 m	✓	●	○	○	WBCL151001A
	Display cable MyTouch 10 m Can also be used to create the "Master-Slave" network between Ultimate Cabin Control units	○	●	○	○	WBCL151005A
	Coupling for display cable MyTouch Can be used to extend MyTouch display cables	○	○	○	○	WBCL151006A

Air Conditioning Control Elements

Electronic Controls

		BlueCool S-Series	BlueCool C-, V-, P-Series	BlueCool A-Series	BlueCool F-Series	Order number
	Remote air temperature sensor with 3 m cable	✓	●**		○	WBCL000813C
	Remote air temperature sensor with 6 m cable	○	●**	○	○	WBCL000810C
	Remote air temperature sensor with 12 m cable	○	●**	○	○	WBCL000812C
	BlueCool CAN-Bus module	○	○	○	○	WBCL1203091B
	Relay box for 2 units – one pump – 230 V	○	○			WBCL001127C
	Relay box for 3 units – one pump – 230 V	○	○			WBCL001128C
	Relay box for 4 units – one pump – 230 V	○	○			WBCL001129C
	Relay box for 2 units – one pump – 115 V	○	○			WBCL001182C
	Relay box for 3 units – one pump – 115 V	○	○			WBCL001183C

✓ Already included in scope of delivery ● Mandatory accessory ○ Optional accessory

* A-Series air handler may also be connected to chiller control directly. In this case no cabin control kit is needed.

** Required if chiller shall run in automatic mode or if air handlers are connected to the chiller electronics.

*** The BlueCool F-2000 Fresh Air can also be installed as a large and silent air handler in combination with the Cabin Control Kit A-Series. (Not for FreshAir application)

Self-Priming Pumps

Model	Dimensions L x W x H	Max. output	Running power consumption	Connection in, out	Weight	Order number 115 V	Order number 230 V	Order number 400 V
Self priming pumps 50/60 Hz								
WB200 • *	195 x 130 x 130 mm 7.7 x 5.2 x 5.2 inch	12/3.2 (l/min.) 3.2/0.9 (gpm)	25 W 0.2 amps (230 V)	5/8", 16 mm	1.2 kg 2.7 lbs	-	WBCL001103B	-
Self priming bronze pumps 50/60 Hz								
WB500G	254 x 120 x 185 mm 10,0 x 4,7 x 7,3 inch	18 (l/min.) 4.7 (gpm)	250 W 1.2 amps (230 V)	G 1/2" F G 1/2" F	6.2 kg	WBCL001306A	WBCL001305A	-
WB1000G	260 x 120 x 143 mm 10.3 x 4.8 x 5.7 inch	60 (l/min.) 15.8 (gpm)	370 W 1.7 amps (230 V)	G 3/4" F G 3/4" F	6.5 kg 14.4 lbs	WBCL001307A	WBCL001092A	-
WB3800G	410 x 215 x 230 mm 16.1 x 8.5 x 9.1 inch	120 (l/min.)	1200 W 5.8 amps (230 V)	G 1 1/4" F	21 kg	-	WBCL001094A	-
Self priming pumps 50 Hz								
WB8000*	592 x 215 x 302 mm 23.4 x 8.5 x 11.9 inch	500 (l/min.) 132 (gpm)	1,600 W 2.9 amps (400 V)	G 2" F G 2" F	19 kg 41.9 lbs	-	-	WBCL001164A
WB10500*	592 x 215 x 302 mm 23.4 x 8.5 x 11.9 inch	667 (l/min.) 176 (gpm)	3,000 W 5.3 amps (400 V)	G 2" F G 2" F	21 kg 46.3 lbs	-	-	WBCL001165A

• Contains straight hose nipple 5/8", 16 mm and 90° adaptor for hose nipple.
* Can only be used for sea water cooling, not for chilled water circulation.

For a stable operation of A/C systems it is essential to have a robust sea water flow in order to cool the condenser and avoid high pressure cut outs of the A/C unit. The sea water pump has to provide this water flow through the A/C unit.

As soon as a significant amount of air is being sucked into the sea water circuit most standard circulation pumps do not have the technical capability to evacuate these air bubbles once they enter into the pump chamber. As a result, the sea water flow stops and the A/C system will shut off. Easy priming pumps do have this capability to evacuate these air bubbles from the pump chamber thus ensuring a continuous A/C operation. Therefore they are the best choice for all those boats and applications where there is a certain risk that air bubbles might enter via the through hull fitting.

Please note that even though the sea water intake fitting is mounted below the sea water line it may happen during heeling, high boat speed or during reversing the boat that air is being sucked into the sea water intake. For such applications it is highly recommended to use self priming sea water pumps instead of standard circulation pumps. The pump models WB500G, WB1000G and WB3800G have to be pre-filled before the first start-up and after long downtimes.

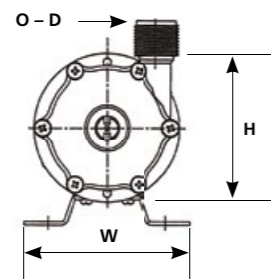
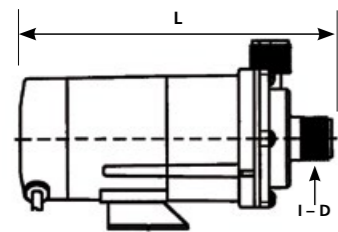

Model WB200



Model WB500G/1000G/2800G



Model WB8000/10500

Pumps

Model	Dimensions L x W x H	Max. output*	Running power consumption	Connection in, out	Weight	Order number 115 V	Order number 230 V	Order number 400 V
Magnetic Drive Pumps 50/60 Hz								
WB250	180 x 95 x 109 mm 7.1 x 3.7 x 4.3 inch	16 (l/min.) 4.2 (gpm)	26 W, 0.36 amps (115 V) 0.18 Amps (230 V)	Ø 14 mm Ø 14 mm	1.6 kg 3.3 lbs	WBCL001301	WBCL001104A	-
WB350	209 x 106 x 105 mm 8.2 x 4.2 x 4.2 inch	27 (l/min.) 7.1 (gpm)	40 W, 0.48 Amps (115 V) 0.24 Amps (230 V)	Ø 18 mm Ø 17 mm	2 kg 4.4 lbs	WBCL001302A	WBCL001105A	-
WB500	248 x 120 x 130 mm 9.8 x 4.8 x 5.2 inch	32 (l/min.) 8.4 (gpm)	60 W 0.4 Amps (230 V)	G 3/4" M G 3/4" M	3.5 kg 7.8 lbs	2510180A	WBCL001101A	-
WB1000	250 x 120 x 130 mm 9.9 x 4.8 x 5.2 inch	45 (l/min.) 11.8 (gpm)	90 W, 1 Amps (115 V) 0.52 Amps (230 V)	G 3/4" M G 3/4" M	3.9 kg 8.6 lbs	WBCL001303A	WBCL001106A	-
WB1500	258 x 130 x 155 mm 10.2 x 5.2 x 6.1 inch	86 (l/min.) 22.7 (gpm)	235 W 1.21 Amps (230 V)	G 1" M G 1" M	6 kg 13.2 lbs	WBCL001304	WBCL001107A	-
WB2000	322 x 156 x 175 mm 12.7 x 6.2 x 6.9 inch	115 (l/min.) 30.3 (gpm)	345 W 1.93 Amps (230 V)	G 1" M G 1" M	8,5 kg 18.8 lbs	-	WBCL001108A	-
Magnetic Drive Pumps 50/60 Hz								
WB3500	423.5 x 149 x 210 mm 16.7 x 5.9 x 8.3 inch	280 (l/min.) 74 (gpm)	370 W, 2.4 Amps (230 V) 1.1 Amps (400 V)	G 1 1/2" M 1 1/2" M	14 kg 30,9 lbs	-	WBCL001109A	WBCL001111A
WB5500	473 x 160 x 249 mm 18.9 x 6.3 x 9.8 inch	320 (l/min.) 84.6 (gpm)	750 W, 3.3 Amps (230 V) 1.8 Amps (400 V)	G 1 1/2" M 1 1/2" M	22 kg 48.5 lbs	-	WBCL001110A	WBCL001112A
WB7400	478.5 x 260 x 274 mm 20.1 x 10.3 x 10.8 inch	450 (l/min.) 118.8 (gpm)	1,500 W, 7.1 Amps (230 V) 3.1 Amps (400 V)	G 2" M G 1 1/2" M	25 kg 55.2 lbs	-	WBCL010121A	WBCL001138
WB9800	478.5 x 260 x 274 mm 22.1 x 10.3 x 10.8 inch	520 (l/min.) 137.4 (gpm)	2,200 W 4.5 Amps (400 V)	G 2" M G 1 1/2" M	32 kg 70.5 lbs	-	-	WBCL001139A
Bronze Pumps 50/60 Hz								
WB2500G	305 x 170 x 195 mm 12 x 6.7 x 7.7 inch	80 (l/min.) 21.1 (gpm)	550 W 2.5 Amps (230 V)	G 1" F G 1" F	13 kg 28.6 lbs	-	2510271A	-
WB3000G	303 x 174 x 181 mm 11.9 x 6.9 x 7.2 inch	125 (l/min.) 33 (gpm)	1,100 W, 4.9 Amps (230 V) 2.8 Amps (400 V)	G 1" F G 1" F	10 kg 22.1 lbs	-	WBCL001171A	WBCL001172A
WB5500G	327 x 157 x 210 mm 12.9 x 6.2 x 8.3 inch	275 (l/min.) 72.6 (gpm)	1,500 W, 6.7 Amps (230 V) 4.5 Amps (400 V)	G 1 1/2" F G 1 1/2" F	19 kg 41.9 lbs	-	2510272A	2510273A

* Effective water output varies with back pressure. Please respect the pump curves on the next pages in order to ensure the minimum water flows required for your applications.
Note: F = Female thread in inch M = Male thread in inch



WB250 to WB1000



WB1500 to WB2000



WB3500 to 9800



WB2500G to 5500G

Pumps

50 Hz water pump curves

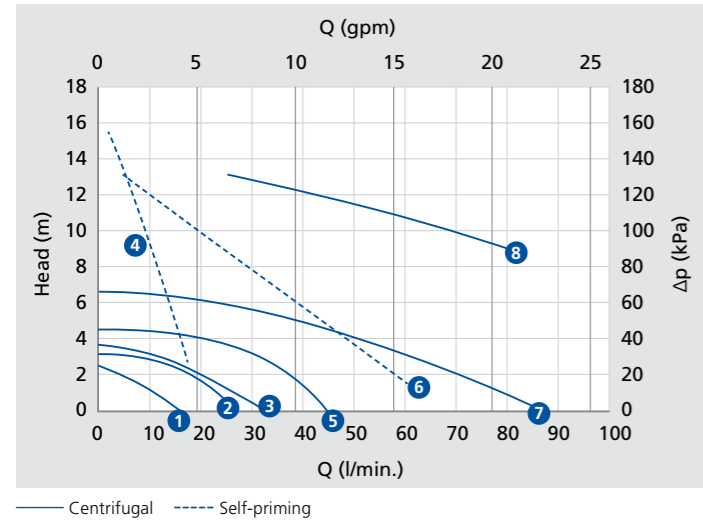

Graphic 1	50 Hz up to 100 l/min.	
1		WB250
2		WB350
3		WB500
4		WB500G
5		WB1000
6		WB1000G
7		WB1500
8		WB2500G

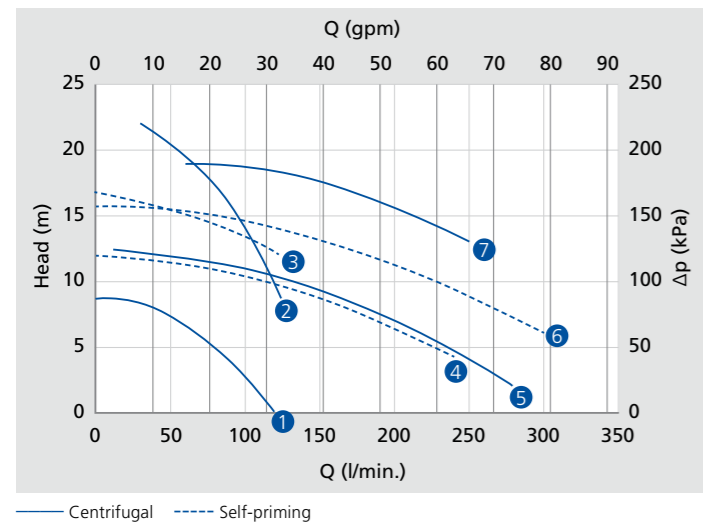

Graphic 2	50 Hz up to 300 l/min.	
1		WB2000
2		WB3000G
3		WB3800G
4		WB4000
5		WB3500
6		WB5600
7		WB5500G

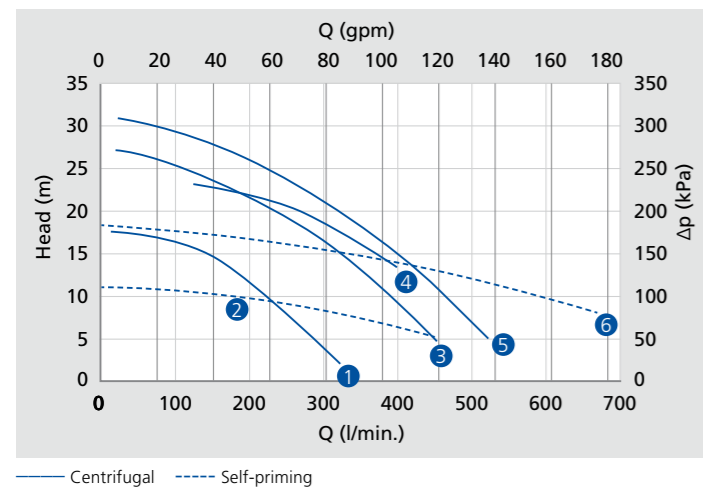

Graphic 3	50 Hz up to 700 l/min.	
1		WB5500
2		WB8000
3		WB7400
4		WB7500
5		WB9800
6		WB10500

Pumps

60 Hz water pump curves

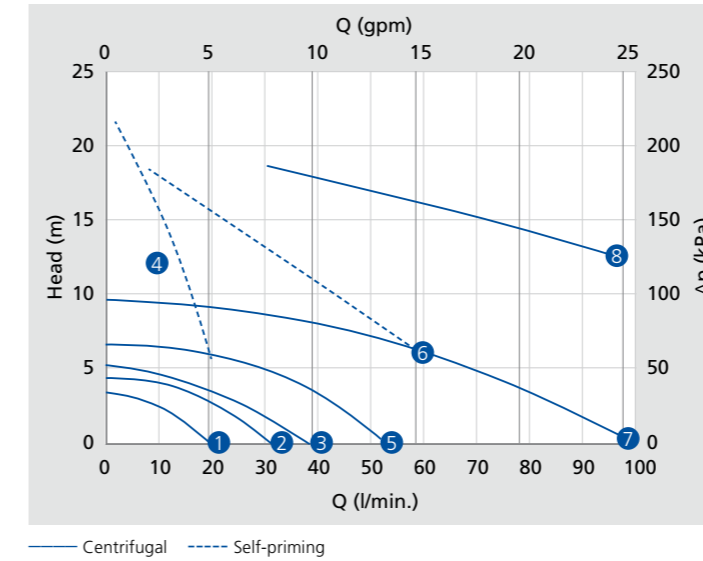

Graphic 4	60 Hz up to 100 l/min.	
1		WB250
2		WB350
3		WB500
4		WB500G
5		WB1000
6		WB1000G
7		WB1500
8		WB2500G

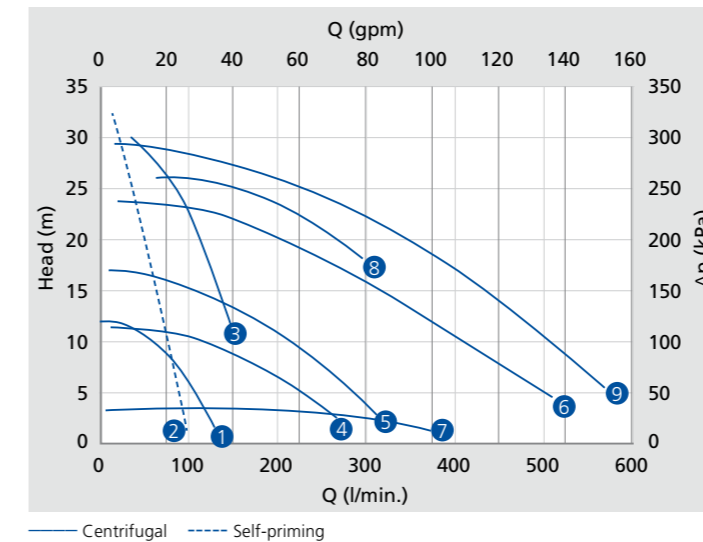

Graphic 5	60 Hz up to 700 l/min.	
1		WB2000
2		WB2800G
3		WB3000G
4		WB3500
5		WB5500
6		WB7400
7		WB7500
8		WB5500G
9		WB9800

- The Head (m) stated in the pump curves (Graphic 1 – 5) represents the equivalent pressure drop between inlet and outlet of the pump. This pressure drop equals the total back pressure of the sea water system from sea water entry to overboard discharge. Please do not confuse it with the position of the pump position below the water line.
- Depending on pressure drop the effective water flow through the pump and thus the sea water system varies significantly.
- Always ensure that the minimum sea water flow through the A/C unit is respected. It should be measured during each commissioning of the system.
- Operating the pumps outside the limits of the pump curves may result in motor overload or cavitation. These cases are excluded from Webasto warranty.

Blowers Modules and Air Flow Regulators

Ultimate Cabin Control – Ultra Silent Blower Operation

Inline blower modules

- Provide fresh air to or extract air from the cabins
- Special fan design provides a high air flow at low noise
- Low electrical power consumption
- Removable engine body allows easy maintenance
- Speed controllable motor, two speed, Class B, IP44

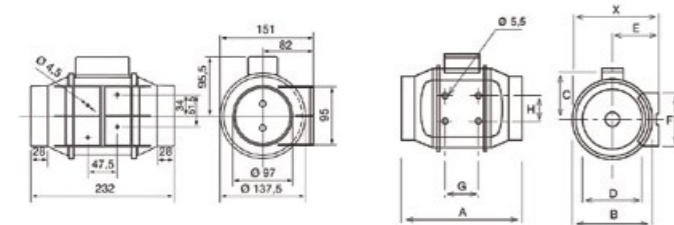

Model 160

Model 250 & 350

Model	X	A	Ø B	C	Ø D	E	F	G	H
250	188	303	176	115	97	100	90	80	60
350	188	258	176	115	123	100	90	80	60

Model	Speed level	Speed (r.p.m.)	Electrical power consumption	Air flow at free discharge	Maximum operating temperature	Sound pressure level* (dB(A))	Power supply	Ø Duct	Weight	Order number
Inline extractor blower 160	II	2,500	20 W	180 m³/h, 106 cfm	40	24	~230 V	100 mm	1.4 kg	WBCL010152A
	I	2,200	12 W	140 m³/h, 82 cfm	40	21	50 Hz	4 inch	3.1 lbs	
Inline extractor blower 250	II	2,200	24 W	240 m³/h, 141 cfm	40	31	~230 V	100 mm	2.0 kg	WBCL010157A
	I	1,850	18 W	180 m³/h, 106 cfm	40	26	50 Hz	4 inch	4.4 lbs	
Inline extractor blower 350	II	2,250	30 W	360 m³/h, 212 cfm	40	33	~230 V	125 mm	2.0 kg	WBCL010158A
	I	1,900	22 W	280 m³/h, 165 cfm	40	28	50 Hz	5 inch	4.4 lbs	
Inline extractor blower 500	II	2,500	50 W	580 m³/h, 341 cfm	60	33	~230 V	150 mm	2.7 kg	WBCL010229A
	I	1,900	44 W	430 m³/h, 253 cfm	60	29	50 Hz	6 inch	5.9 lbs	

* Sound pressure level radiated at 3 meters at free air conditions with rigid ducts at the inlet and at the outlet.

Air flow regulators

- Independent regulation of desired fresh-/extract air flow
- Eliminates the influence of alternating back pressure, caused by e.g. blocked air filters
- Continuous air flow ensures high comfort inside the cabin
- No electrical or pneumatic wiring
- Direct insertion into the air duct, which allows an easy application



Model	Ø D of ducting	Air flow limit	Order number
Air Flow Regulator 15	80 mm, 3.1 inch	15 m³/h, 8.5 cfm	WBCL005243
Air Flow Regulator 30	80 mm, 3.1 inch	30 m³/h, 17.5 cfm	WBCL005244
Air Flow Regulator 45	80 mm, 3.1 inch	45 m³/h, 26.5 cfm	WBCL005245
Air Flow Regulator 60	80 mm, 3.1 inch	60 m³/h, 35 cfm	WBCL005246
Air Flow Regulator 90	100 mm, 4 inch	90 m³/h, 53 cfm	WBCL005247
Air Flow Regulator 120	125 mm, 5 inch	120 m³/h, 70.5 cfm	WBCL005248
Air Flow Regulator 160	125 mm, 5 inch	160 m³/h, 94 cfm	WBCL005249

Air System

Functioning Principals

Minimum air grille sections

To obtain acceptable noise levels at maximal blower speed levels the requirements for grille and ducts sections should be observed. The size of the transition box behind the supply air-grille is also important.

Capacity BlueCool A/C component	Duct size S-Series (mm)	Duct size A-Series (mm)	Supply air grill (cm²)	Recommended supply air grill (")	Return air grill (cm²)	Recommended return air grill (")
4,000 BTU/h	–	100	150	8 x 4	325	12 x 5
6,000 BTU/h	–	125	190	10 x 4	490	11 x 8
8,000 – 10,000 BTU/h	100 – 125	125	235	12 x 4	490	11 x 8
12,000 – 13,000 BTU/h	125 – 150	150	250	10 x 5	550	14 x 7
16,000 – 20,000 BTU/h	125 – 150	150	390	12 x 6	800	14 x 10
24,000 BTU/h	–	2 x 150	2 x 250	2 x 10 x 5	1,000	14 x 12
27,000 BTU/h	2 x 150	–	650	2 x 12 x 6	1,600	2 x 14 x 10
36,000 BTU/h	–	2 x 150	2 x 380	2 x 12 x 6	1,600	2 x 14 x 10

Blower outlets

90° turns with flexible ducts directly from blower outlets should be avoided at all costs as they introduce severe restrictions in the air-flow. All WB blowers (except on 24,000 BTU/h models) can be rotated through 45° steps to obtain a straight-line outlet from the blower. This facility should be used whenever possible.

Return grille offset

It should be avoided to place a return air grille directly opposite the finned coil surface of an air handler, because this will allow propagation of direct blower-motor noise through the grille. The grille should be offsetted to chicane the return air to the coil inlet. Direct noise propagation will be reduced in a significant manner.





Duct type

To avoid accidental crushing, flexible air-ducts should be of high quality with sufficiently strong steel spiral reinforcement. Spiral type ducts should be extended to their maximum length for the best interior smoothness. For very long duct sections smooth bore ducts (in PVC for example) should be preferred. This offers better smoothness than flexible spiral type ducting and hence reduces internal friction. For very short lengths non-insulated ducts can be used. For greater lengths it is advisable to use insulated type ducts to avoid condensation on the outside of the air-ducts.

Big luxury yacht

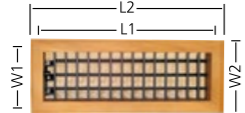
In general requirements for megayachts and big luxury vessels are even more stringent than the table here above. These special requirements can be obtained from Webasto on request.

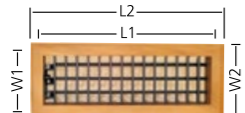
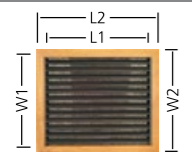
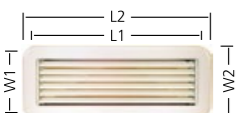
Air System

Air grille*	Model	L1 (mm)	L2 (mm)	W1 (mm)	W2 (mm)	Order number
	8 x 4 TS (supply air)	202	230	100	128	WBCL004000XA
	10 x 4 TS	252	281	100	128	WBCL004001XA
	12 x 4 TS	304	332	100	128	WBCL004002XA
	10 x 5 TS	252	281	125	152	WBCL004018XA
	12 x 5 TS	304	332	125	152	WBCL004004XA
	12 x 6 TS	304	332	152	179	
Wedge type supply air grille*	Model	L1 (mm)	L2 (mm)	W1 (mm)	W2 (mm)	Order number
	10 x 5 WGT (supply air)	-	280	-	150	WBCL004023XA
Air grille, closeable*	Model	L1 (mm)	L2 (mm)	W1 (mm)	W2 (mm)	Order number
	8 x 4 TSC (supply air)	202	230	100	128	WBCL004005XA
	10 x 4 TSC	252	281	100	128	WBCL004019XA
	12 x 4 TSC	304	332	100	128	WBCL004006XA
	10 x 5 TSC	252	281	125	152	WBCL004022XA
	12 x 5 TSC	304	332	125	152	WBCL004025XA
Air grille with filter*	Model	L1 (mm)	L2 (mm)	W1 (mm)	W2 (mm)	Order number
	12 x 5 TR (return air)	304	332	125	152	WBCL004020XA
	11 x 8 TR	280	306	204	230	WBCL004017XA
	14 x 7 TR	177	205	355	381	WBCL004007XA
	12 x 10 TR	304	332	254	281	WBCL004021XA
	14 x 10 TR	354	382	254	281	WBCL004008XA
	14 x 12 TR	354	382	304	332	WBCL004009XA
Air grille (ABS)	Model	L1 (mm)	L2 (mm)	W1 (mm)	W2 (mm)	Order number
	10 x 4 PS (ABS, supply air)	242	280	92	128	WBCL004030A
	12 x 4 PS	292	332	92	128	WBCL004031A
	10 x 5 PS	242	280	115	152	WBCL004032A
	10 x 6 PS	242	280	138	174	WBCL004033A
	Air grille (ABS) with filter	Model	L1 (mm)	L2 (mm)	W1 (mm)	W2 (mm)
	10 x 8 PR (ABS, return air)	242	281	190	232	WBCL004076A
	10 x 10 PR	242	281	242	281	WBCL004077A
	12 x 12 PR	292	332	292	332	WBCL004078A
	14 x 10 PR	342	382	242	281	WBCL004080A
	14 x 12 PR	342	382	292	332	WBCL004081A

* Note: All teak grilles can be supplied in other wood qualities on demand. Please see table listing the special suffixes to the chosen grille item code in accordance with the wood type preference.







In order to customise the wooden air grilles, please choose from the following wood options:

Example: WBCL0040040 = Teak air grille 12 x 5 WBCL0040042 = Mahogany air grille 12 x 5

Suffix	Wood type	Description
0	Teak	Asian Teak
1	Cherry	American Cherry
2	Mahogany	Honduran Mahogany
4	Oak	American white Oak

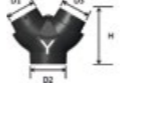
Note: Teak versions on stock. Other wood options may have longer lead times or extra shipping costs.

Air System



T-piece (inside, D2 direct to A/C unit)	Model	D1 / D2 / D3 (mm)	L x H (mm)	Order number	
	100/100 F/100	100/100 F/100	220 x 185	-	WBCL001549A
	100/125 F/100	125/100 F/100	220 x 185	-	WBCL001560A
	125/125 F/100	125/125 F/100	220 x 185	-	WBCL001550A
	125/125 F/125	125/125 F/125	220 x 185	-	WBCL001555A
	T-piece (outside, D2 connected to hose)	Model	D1 / D2 / D3 (mm)	L x H (mm)	Order number
	100/100 M/100	100/100 M/100	220 x 185	-	WBCL001551A
	100/125 M/100	100/125 M/100	220 x 185	-	WBCL001552A
Y-piece (inside, D2 direct to A/C unit)	Model	D1 / D2 / D3 (mm)	L x H (mm)	Order number	
	100/125 F/100	100/125 F/100	269 x 213	-	WBCL001576A
	100/125 F/125	100/125 F/125	269 x 213	-	WBCL001577A
Y-piece (outside, D2 connected to hose)	Model	D1 / D2 / D3 (mm)	L x H (mm)	Order number	
	100/100 M/100	100/110 M/100	250 x 200	-	WBCL001578A
	100/125 M/100	100/125 M/100	269 x 213	-	WBCL001574A
	100/125 M/125	100/125 M/125	269 x 213	-	WBCL001575A
	125/150 M/125	125/150 M/125	280 x 220	-	WBCL001580A
	150/150 M/150	150/150 M/150	280 x 220	-	WBCL001581A
Hose adapter	Model	D1 / D2 / D3 (mm)	L x H (mm)	Order number	
	3" x 4"	106 x 70	106 x 70	-	WBCL001579A
90 degree elbow-piece, D2 connected to A/C unit	Model	D1 / D2 (mm)	L x H (mm)	Order number	
	100 M/100 F	100 M/100 F	173 x 172	-	WBCL001572A
	125 M/125 F	125 M/125 F	194 x 198	-	WBCL001573A
90 degree elbow-piece, D2 connected to hose	Model	D1 / D2 (mm)	L x H (mm)	Order number	
	100 M/100 M	100 M/100 M	170 x 170	-	WBCL001570A
	125 M/125 M	125 M/125 M	195 x 195	-	WBCL001571A
Standard transition box	Model	L x H (mm)	W (mm)	Order number	
	8 x 4"	-	252 x 130	150	WBCL001501A
	10 x 4"	-	304 x 130	150	WBCL001502A
	12 x 4"	-	352 x 130	150	WBCL001503A
	12 x 5"	-	352 x 130	180	WBCL001505A
	10 x 5"	-	304 x 130	180	WBCL001506A
	12 x 6"	-	352 x 130	200	WBCL001507A
	10 x 6"	-	304 x 130	200	WBCL001508A

F = Female M = Male
* Equivalent diameter of air ducting in mm

Air System

Standard hose rings	Model	D (mm)	W (mm)	Order number	
	HR4 – 100	100	134	WBCL002502	
	HR5 – 125	125	150	WBCL002503	
	HR6 – 150	150	170	WBCL002504A	
	HR7 – 178	175	200	WBCL002509A	
Oval hose rings	Model	D x W2 (mm)	L x H (mm)	W1 (mm)	Order number
	HO4 – 100*	120 x 55	170	100	WBCL002505A
	HO5 – 125*	150 x 65	195	110	WBCL002506A
	HO6 – 150*	180 x 72	228	120	WBCL002507A
	HO7 – 175*	200 x 84	255	140	WBCL002508A
Transition box, round entry	Model	D (mm)	L x H (mm)	W (mm)	Order number
	8 x 4LN/100*	100	250 x 130	150	WBCL001520A
	10 x 4LN/100*	100	305 x 130	150	WBCL001521A
	12 x 4LN/100*	100	360 x 130	150	WBCL001522A
	10 x 5LN/125*	125	304 x 130	180	WBCL001523A
Transition box, lateral oval entry	Model	D x W2 (mm)	L x H (mm)	W (mm)	Order number
	8 x 4LT/OV100*	120 x 55	250 x 130	155	WBCL001510A
	10 x 4LT/OV100*	120 x 55	305 x 130	155	WBCL001530A
	10 x 4LT/OV125*	150 x 65	305 x 130	155	WBCL001529A
	12 x 4LT/OV125*	150 x 65	305 x 130	180	WBCL001528A
Transition box, back oval entry	Model	D x W2 (mm)	L x H (mm)	W (mm)	Order number
	8 x 4AR/OV100*	120 x 55	250 x 180	155	WBCL001524A
	10 x 4AR/OV100*	120 x 55	305 x 180	155	WBCL001525A
	10 x 4AR/OV125*	150 x 65	305 x 180	155	WBCL001531A
	10 x 5AR/OV125*	150 x 65	305 x 180	180	WBCL001526A
	10 x 6AR/OV125*	150 x 65	305 x 180	205	WBCL001533A
Y-piece	Model	D / D1 / D2 (mm)	L x H (mm)	Order number	
	YAS100	100/100/100	320 x 255	WBCL001562A	
	YAS125	125/125/125	360 x 300	WBCL001563A	
	YAS100/80/80	100/80/80	380 x 300	WBCL001548A	
Webasto EasyDuct – Insulated flexible air ducts	Model (mm)	D (mm)	L (m)	Order number	
	80	IN = 80; A = 90	L = 6	WBCL007463A	
	102	IN = 102; A = 112	L = 6	WBCL007464A	
	127	IN = 127; A = 137	L = 6	WBCL007465A	
	152	IN = 152; A = 162	L = 6	WBCL007472A	
Standard flexible air ducts	Model (mm)	D (mm)	L (m)	Order number	
	Cflex 102	102	10	WBCL001804B	
	Cflex 127	127	10	WBCL001805B	
	Cflex 150	152	10	WBCL001806B	

Air System

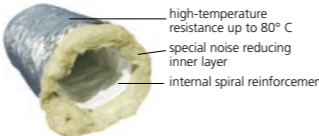
Insulated flexible air ducts	Model	D (mm)	L (m)	Order number
	Cflexiso 102	102	10	WBCL001807B
	Cflexiso 127	127	10	WBCL001808B
	Cflexiso 152	152	10	WBCL001809B
Tubular hose insulation	Model	D (mm)	L (m)	Order number
	Isosleeve 102	102	10	WBCL001810
	Isosleeve 127	127	10	WBCL001811
	Isosleeve 152	152	10	WBCL001812
Extra silent insulated air ducts	Model	D (mm)	L (m)	Order number
	–	102	10	WBCL010155A
	–	127	10	WBCL010156A
	–	160	10	WBCL010206B

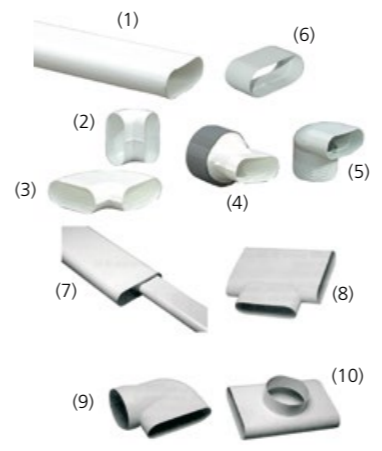
Oval ducts	Description	Model (mm)	L (m)	Order number
	Oval duct (1)	100 x 40	3	WBCL007100
	Oval duct (1)	200 x 60	3	WBCL007106
	Elbow 90° (2)	100 x 40	–	WBCL007105
	Elbow 90° (2)	200 x 60	–	WBCL007108
	Elbow 90° – flat (3)	100 x 40	–	WBCL007104
	Elbow 90° – flat (3)	200 x 60	–	WBCL007111
	Junction oval/round (4)	100 x 40/100	–	WBCL007102A
	Junction oval/round (4)	100 x 40/80	–	WBCL007117
	Junction oval/round (4)	200 x 60/125	–	WBCL007109
	Junction oval/round (5)	100 x 40/100	–	WBCL007103A
Junction oval/round (5)	200 x 60/125	–	WBCL007110	
Junction oval (6)	100 x 40	–	WBCL007101	
Junction oval (6)	200 x 60	–	WBCL007107	
Reduction (7)	200 to 100	–	WBCL007112	
Oval t (8)	200 x 60	–	WBCL007114	
Adapter oval/round (9)	200 x 60/125	–	WBCL007115	
Oval/round t (10)	200 x 60/125	–	WBCL007116	

* Equivalent diameter of air ducting in mm.

Webasto Easy Pipe

The Solution to Reduce Installation Time and Save Costs

Benefits

- Easy assembly process, reliable application
- Pipes have pre-mounted insulation providing significant saving on installation time for boat builders
- Huge range of compatible quick-fitting components

Specifications

- Pipe material is high-quality polybutylene with a temperature range of -30°C up to 90°C at 6 bar
- Pipe insulation is high-quality closed cell polyethylene (PE-LD) with a temperature range of -30°C to 95°C and a lambda value of 0.0334 W/(m · K)
- O-ring sealed push fittings with stainless steel locking
- Sold in rolls to be cut to length

Webasto Easy Pipe	Chilled water pipes (mm)	Model (mm)	Packaging (m)	Order number
	d22/D48	22	25	6241037A
	d28/D54	28	25	6241038A

Water System	Description	Model (mm)	Packaging (m)	Order number
	Hep ₂ O PB Barrier Pipe	15	L = 50	WBCL010300B
	Hep ₂ O PB Barrier Pipe	22	L = 50	WBCL010301B
	Hep ₂ O PB Barrier Pipe	28	L = 25	WBCL010302B





	Description	Model (mm)	Packaging (pieces)	Order number
	Hep ₂ O Straight Connector 15	15	10	WBCL010307B
	Hep ₂ O Straight Connector 22	22	10	WBCL010308B
	Hep ₂ O Straight Connector 28	28	10	WBCL010309B
	Hep ₂ O PB Elbow 90° 15	15	10	WBCL010325B
	Hep ₂ O PB Elbow 90° 22	22	10	WBCL010326B
	Hep ₂ O PB Elbow 90° GY 28	28	10	WBCL010327B
	Hep ₂ O PB Tee 90° 15	15 x 15 x 15	10	WBCL010337B
	Hep ₂ O PB Tee 90° 22	22 x 22 x 22	10	WBCL010338B
	Hep ₂ O PB Tee 90° GY 28	28 x 28 x 28	10	WBCL010342B
	Hep ₂ O PB Tee 90° 22 x 22 x 15	22 x 22 x 15	5	WBCL010339B
	Hep ₂ O PB Tee 90° 22 x 15 x 22	22 x 15 x 22	5	WBCL010340B
	Hep ₂ O PB Tee 90° 22 x 15 x 15	22 x 15 x 15	5	WBCL010341B
	Hep ₂ O PB Tee 90° 28 x 15	28 x 15 x 28	5	WBCL010343B
	Hep ₂ O PB Tee 90° 28 x 28 x 22	28 x 28 x 22	5	WBCL010344B
	Hep ₂ O PB Tee 90° 28 x 22 x 28	28 x 22 x 28	5	WBCL010345B
	Hep ₂ O Pb Tee Reduced Both Ends	W 22 x 15	-	WBCL010700A
	Hep ₂ O Pb Tee Reduced Both Ends	W 28 x 15	-	WBCL010701A
	Hep ₂ O Hepkey Plus 15	-	-	WBCL010702A
	Hep ₂ O Hepkey Plus 22	-	-	WBCL010703A
	Hep ₂ O Hepkey Plus 28	-	-	WBCL010704A
	Hep ₂ O Silicone Lubricant Spray 400 ml Aerosol Can Hep ₂ O Fittings	-	-	WBCL010705A

Water System

Functioning Principals

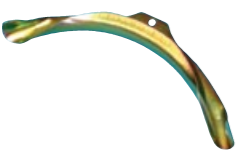
	Description	Model (mm)	Packaging (pieces)	Order number
	Hep ₂ O reducer 22 x 15 S/SP	22 x 15	10	WBCL010379B
	Hep ₂ O reducer 28 x 22 S/SP	28 x 22	10	WBCL010380B
	Hep ₂ O Straight Tap Connector 15 x 1/2"	15 x 1/2"	10	WBCL010316B
	Hep ₂ O Straight Tap Connector 15 x 3/4"	15 x 3/4"	5	WBCL010317B
	Hep ₂ O Straight Tap Connector 22 x 3/4"	22 x 3/4"	5	WBCL010318B
	Hep ₂ O Bent Tap Connector 15 x 1/2"	15 x 1/2"	10	WBCL010328B
	Hep ₂ O Brass Female Adapt 15 x 1/2"	15 x 1/2"	10	WBCL010310B
	Hep ₂ O Brass Female Adapt 22 x 3/4"	22 x 3/4"	10	WBCL010312B
	Hep ₂ O Brass Female Adapt 28 x 1"	28 x 1"	10	WBCL010314B
	Hep ₂ O Brass Male Adapt 15 x 1/2"	15 x 1/2"	10	WBCL010311B
	Hep ₂ O Brass Male Adapt 22 x 3/4"	22 x 3/4"	10	WBCL010313B
	Hep ₂ O Brass Male Adapt 28 x 1"	28 x 1"	10	WBCL010315B
	Hep ₂ O Brass Spgt Adapt 15 x 1/2" Female	15 x 1/2"	10	WBCL010319B
	Hep ₂ O Brass Spgt Adapt 22 x 3/4" Female	22 x 3/4"	10	WBCL010321B
	Hep ₂ O Brass Spgt Adapt 28 x 1" Female	28 x 1"	10	WBCL010323B
	Hep ₂ O Brass Spgt Adapt 15 x 1/2" Male	15 x 1/2"	10	WBCL010320B
	Hep ₂ O Brass Spgt Adapt 22 x 3/4" Male	22 x 3/4"	10	WBCL010322B
	Hep ₂ O Brass Spgt Adapt 28 x 1" Male	28 x 1"	10	WBCL010324B
	Hep ₂ O Brass Ball Valve 15	15	5	WBCL010353B
	Hep ₂ O Brass Ball Valve 22	22	5	WBCL010354B
	Hep ₂ O Shut off valve Hot/Cold 15	15	5	WBCL010375B

Water System





	Description	Model (mm)	Packaging (pieces)	Order number
	Hep ₂ O Cold Forming Bend Fixture 15	15	5	WBCL010335B
	Hep ₂ O Cold Forming Bend Fixture 22	22	5	WBCL010336B
	Hep ₂ O Pipe Support Sleeve 15	15	10	WBCL010362B
	Hep ₂ O Pipe Support Sleeve 22	22	10	WBCL010364B
	Hep ₂ O Pipe Support Sleeve 28	28	5	WBCL010366B
	Hep ₂ O Pipe cutter 10 – 28 Standard	–	1	WBCL010373B
	Hep ₂ O Pipe cutter 10 – 28 Professional	–	1	WBCL010374B

Important Note:

ALL Hep₂O FITTINGS ARE PRE-LUBRICATED – NO ADDITIONAL LUBRICATION REQUIRED.

If the fitting is demounted and remade, the use of Hep₂O Silicone Lubricant Spray (HX200) is recommended. HX200 is the only lubricant recommended for use with Hep₂O.

Water System

	Expansion tank	Order number
	Model 2,5 liter (1)	WBCL002030
	Model 8 liter (2)	WBCL002031B
	Automatic air bleeder (3) for chiller circuits, 3/8" = 15 mm	WBCL002035A
	TA Hydronics flow regulators	Order number
	Model STAD-15 – diameter 15 mm (5/8")	WBCL002100B
	Model STAD-20 – diameter 20 mm (3/4")	WBCL002101B
	Model STAD-25 – diameter 25 mm (1")	WBCL002102B
	3-way valve	Order number
	3-way motorized valve DN20-G3/4"	2510335A
	3-way motorized valve DN25-G1"	2510336A
	3-way motorized valve DN32-G1 1/4"	2510338A
	Turn ball valve	Order number
	1/4 Turn ball valve – diameter 12 mm	WBCL002015A
	1/4 Turn ball valve – diameter 15 mm	WBCL002016A
	1/4 Turn ball valve – diameter 20 mm	WBCL002017A
	1/4 Turn ball valve – diameter 25 mm	WBCL002018A
	Chilled water hoses and accessories	Order number
	Hose D12 with insulation 9 x 18 mm – 25 m (1)	WBCL002001A
	Hose D15 with insulation 9 x 22 mm – 25 m (1)	WBCL002002A
	Hose D20 with insulation 9 x 28 mm – 25 m (1)	WBCL002003A
	Hose D25 with insulation 9 x 35 mm – 25 m (1)	WBCL001999A
	Hose D15 without insulation – 25 m (2)	WBCL002005A
	Hose D20 without insulation – 25 m (2)	WBCL002006A
	Hose D25 without insulation – 25 m (2)	WBCL002000A
	Tubular insulation for D12; 9 x 18 mm – 2 m (4)	WBCL002007
	Tubular insulation for D15; 9 x 22 mm – 2 m (4)	WBCL002008A
	Tubular insulation for D20; 9 x 28 mm – 2 m (4)	WBCL002009A
	Tubular insulation for D25; 9 x 35 mm – 2 m (4)	WBCL002829A
	Adhesive foam, 50 mm wide – 15 m roll (5)	WBCL002010A
	T-piece 19-19-19 for hose D20 (3)	WBCL002011A
	T-piece 15-15-15 for hose D15 (3)	WBCL002019A

Pipe insulation closed, foam	d (mm)	D (mm)	Length (m)	pc./box	for ABS:	Min. Order	Order number
	28	54	2	78	DN25	10	WBCL002830
	35	60	2	58	DN32	10	WBCL002831

thickness: 13 mm

Water System

	Sea water strainer	Order number	
	G 3/4" model 1160, height 105 mm, nickel-plated brass	WBCL010109A	
	G 1" model 1164, height 144 mm, nickel-plated bronze	WBCL010110A	
	G 1 1/4" model 1164, height 178 mm, nickel-plated bronze	WBCL010111A	
	G 1" model 1162, height 151 mm, nickel-plated bronze	WBCL010112A	
	G 1 1/4" model 1162, height 176 mm, nickel-plated bronze	WBCL010113A	
	Screen filter element for model 1160	WBCL010268A	
	Sea-water strainer, 16 – 20 mm, with two nipples	Order number	
	Capacity in US gallons 350/1,000 US gallons/h Capacity in liters 25/50 l/min. Suitable for pump models WB250 – WB350/1000 H = 140 mm W = 100 mm		
	D = diameter inlet/outlet 5/8" – 16 mm	WBCL001151A	
	D = diameter inlet/outlet 3/4" – 20 mm	WBCL001152A	
	Screen-filter element 1,000 Microns	WBCL001154	
		Sea-water strainer, 25 mm, with two nipples	Order number
		Capacity in US gallons 1,000 US gallons/h Capacity in liters 50 l/min. Suitable for pump models WB1000 to 2000 H = 290 mm W = 144 mm	
D = diameter inlet/outlet 1.25" – 32/40 mm			
1" – 25 mm		WBCL001153A	
Screen-filter element 1,000 Microns		WBCL001155	
		Through-hull kits 16, 20, 25 mm	Order number
		Capacity in US gallons 350 / 1,000 – 25 / 50 l / min. Suitable for pump models WB250 – WB350/1000 D = diameter inlet/outlet, 5/8" – 16 mm kit, 1/2" – 16 D = diameter inlet/outlet, 3/4" – 20 mm kit, 3/4" – 20	
	5/8" – 16 mm – 1 plastic valve (1 + 2 + 3)	WBCL001125A	
	3/4" – 20 mm – 1 plastic valve (1 + 2 + 3)	WBCL001126C	
	5/8" – 16 mm + 2 x 90° plastic valve (1 + 3 + 5)	WBCL001123C	
	3/4" – 20 mm + 2 x 90° plastic valve (1 + 3 + 5)	WBCL001124A	
	Kit 5/8" – 16 mm – 1 nickel plated valve (1 + 4 + 2)	WBCL001175A	
	Kit 3/4" – 20 mm – 1 nickel plated valve (1 + 4 + 2)	WBCL001176A	
	Kit 5/8" – 16 mm – 2 nickel plated valves/bronze exit (1 + 4 + 5)	WBCL001177A	
	Kit 3/4" – 20 mm – 2 nickel plated valves/bronze exit (1 + 4 + 5)	WBCL001178A	
	Kit 1" – 25 mm – 1 nickel plated valve/plastic exit (1 + 4 + 2)	WBCL001179A	

Water System

	Air bleeder t-piece for chilled water system	Order number
	Model 1000S (for pump WB1000): t-piece 3/4", diameter shut-off valve outlet 1/2" – 16 mm	WBCL001121A
	Model 2000S (for pumps WB1500 – 2500): t-piece 1", diameter shut-off valve outlet 3/4" – 20 mm	WBCL001122A
	Chilled Water Circuit A/C Calorifiers	Order number
	With safety thermostat	
	Model 15 kW; 400 V; L = 1,015 mm; H = 200 mm; weight = 11 kg	WBCL002121
	Model 30 kW; 400 V; L = 1,590 mm; H = 200 mm; weight = 19 kg	WBCL002123
	Air bleeder for seawater pumps	Order number
	Model 350R (for pumps WB250 and WB350): t-piece 3/4", diameter supply and outlet 1/2" – 16 mm	WBCL001118A
	Model 1000R (for pump WB1000): t-piece 3/4", diameter supply and outlet 3/4" – 20 mm	WBCL001119A
	Model 2000R (for pumps WB1500 – 2500): t-piece 1", diameter supply and outlet 3/4" – 20 mm	WBCL001120A

Webasto can provide all accessories for pressurized systems. Please contact us for further details.

Accessories for S-, V- and C- Series



- Reduction of electrical starting peak up to 70 %
- For all BlueCool single-phase compressors
- Fully 50/60 Hz compatible for worldwide application
- Self-adjusting software adapts to compressor type and frequency input
- Monitors supply voltage and protects against low voltage and locked rotor
- Easy to install and to retrofit in BlueCool electrical boxes

BlueCool Soft Start

Description	Order number
BlueCool Soft Start 5,000 – 13,000 BTU/h, 230 V, single-phase, 50 – 60 Hz	WBCL050931B
BlueCool Soft Start 16,000 – 20,000 BTU/h, 230 V, single-phase, 50 – 60 Hz	WBCL050932B
BlueCool Soft Start 24,000 – 42,000 BTU/h, 230 V, single-phase, 50 – 60 Hz	WBCL050933B



- Reduction of starting peak up to 53 %
- Fully 50/60 Hz compatible for worldwide application
- Two soft start models cover 3-phase scroll compressors from 21 – 143 kBTU/h
- Self-adjusting software, soft start automatically adapts to compressor
- Monitors supply voltage and protects against overvoltage, overcurrent and locked rotor
- Rated operational voltage: 340 – 440 VACrms, 50/60 Hz

Soft Start 3-phase, 400 V

Description	Order number
Soft Start 21 – 96 kBTU, 400 V, 3-phase, 50 – 60 Hz	WBCL050945A
Soft Start 112 – 143 kBTU, 400 V, 3-phase, 50 – 60 Hz	WBCL050946A



- Reduction of 50 % of vibrations transmitted to the hull
- High performance damping elements specially designed for the vibration frequency and the weight of each unit
- All absorbers can easily be retrofitted and mounted below the condensate tray. One complete kit with all necessary parts is supplied
- The height of the unit will be increased by only 14 mm

BlueCool Vibration absorber kits

Description	Order number
Vibration Absorber Kit S-Series; S6, S8, S10	WBCL120075A
Vibration Absorber Kit S-Series; S13 – S27	WBCL120076A
Vibration Absorber Kit C-Series; C16 M – C27 M	WBCL120078A



- Solution for C-Series with Twin, Triple and Quattro compressors as well as for the V50 M
- One complete kit with all necessary parts is supplied

BlueCool Silent block kits

Description	Order number
Silent Blocks for C32 T, C40 T, C55 T, V50 M, V64 T and V77 T	WBCL1207041A
Silent Blocks for C81 R and C108 Q	WBCL1207042A

BlueCool Expert Tool

Service Software for A/C Systems

- Free Webasto service software suitable for all new air-conditioning units of the A-/S-/C-/V-/P-/F-Series. Your best companion for easy parameterizing and servicing of the A/C system.
- Plug-and-play USB connection to the A/C unit
 - Standard USB connection
- Remote troubleshooting
 - Remote access via internet
- Easy parameter setting
 - All parameters at one sight
- Back-up and upload of application-specific presets
 - Save individual presets or load standard presets
- Real-time system monitoring
 - Check all data of system while operating
- Access to data logs
 - All relevant data are stored for easy review
- Activation/test of A/C system components
 - Check function of all components and connected accessories

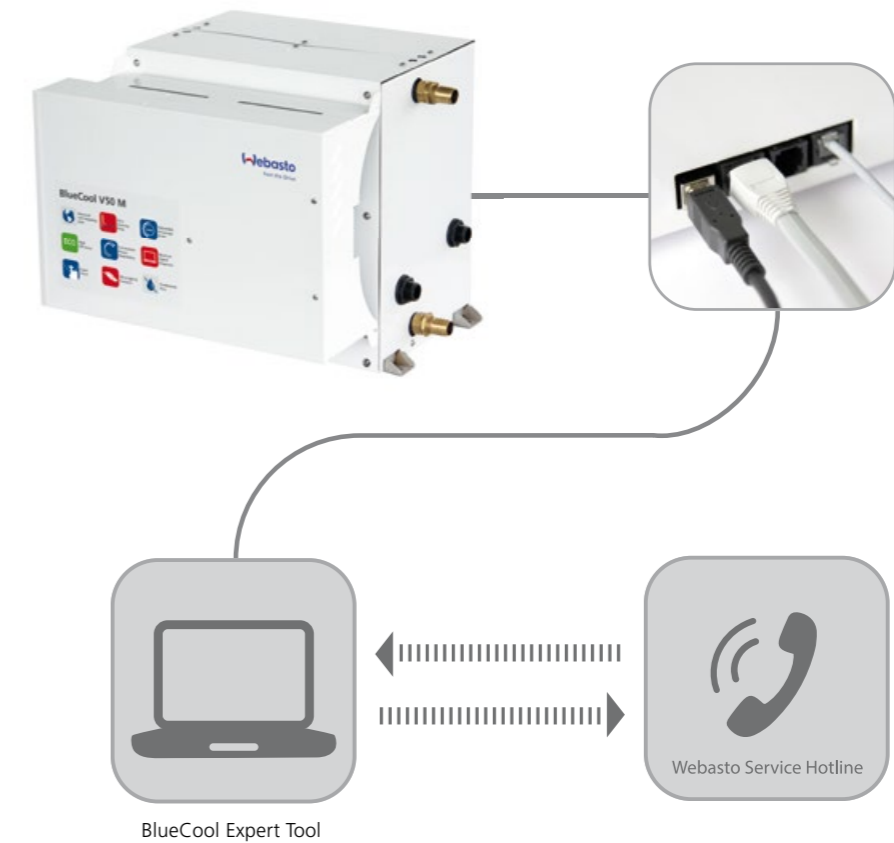



Integrated Solutions

Integrated Solutions	162
<hr/>	
BlueComfort Premium	166
Application Concept	166
Application Guidelines	167
Basic Integration	168
DeLuxe Integration	169

Integrated Solutions



Webasto BlueComfort solutions combine an air-conditioning unit and a water heating unit into one integrated system. This allows yacht owners and sailors to expand the boating season as people can choose between heating and cooling at the push of a button.

Most air-conditioning systems have a reverse cycle function to enable heating with the A/C system. However, this requires mild sea water temperatures for efficient heating. Below 6°C sea water temperature the heat cycle becomes inefficient. Along with this the expense and inconvenience of having to run generators and consuming battery power to supply heat over night can be removed. To gain total autonomy from environmental conditions, an integrated water heater is the perfect solution.

BlueComfort Premium

- Integration of a chiller A/C unit and a diesel-operated water heater into one system
- Comfort like at home in any weather condition
- Modular concept allowing multiple configurations
- Full range of solutions for any size of boat

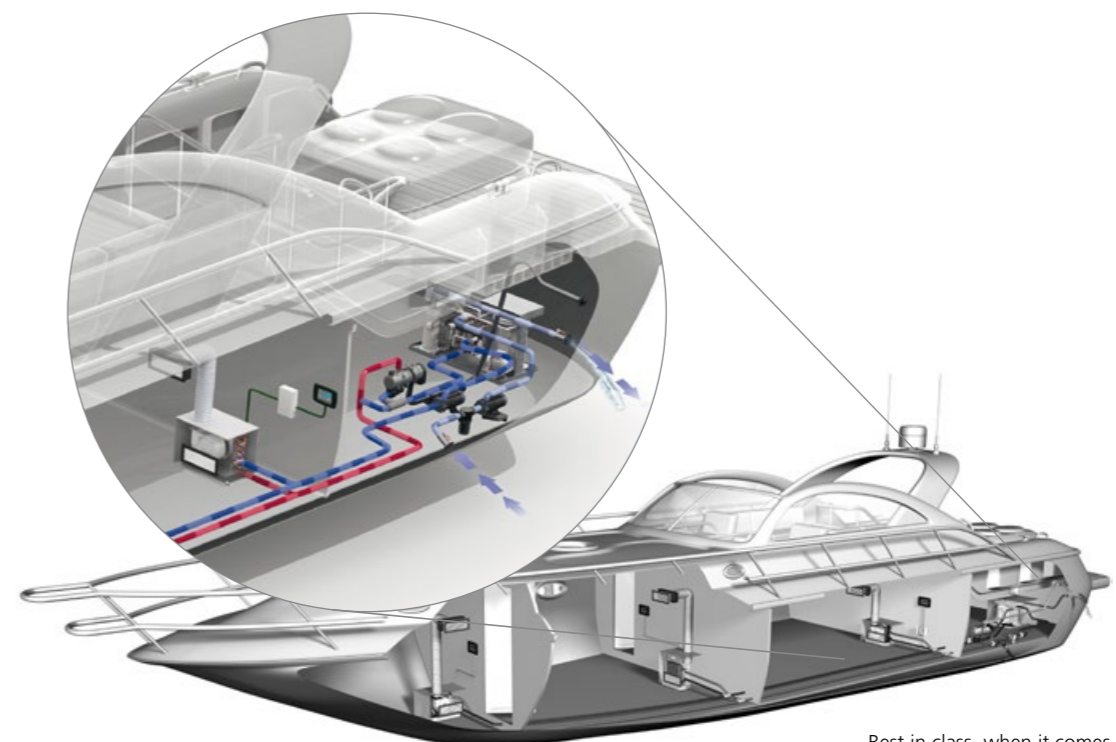

Best in class, when it comes to complete climate comfort: Chiller A/C unit and a powerful water heater.

BlueComfort Premium

Application Concept

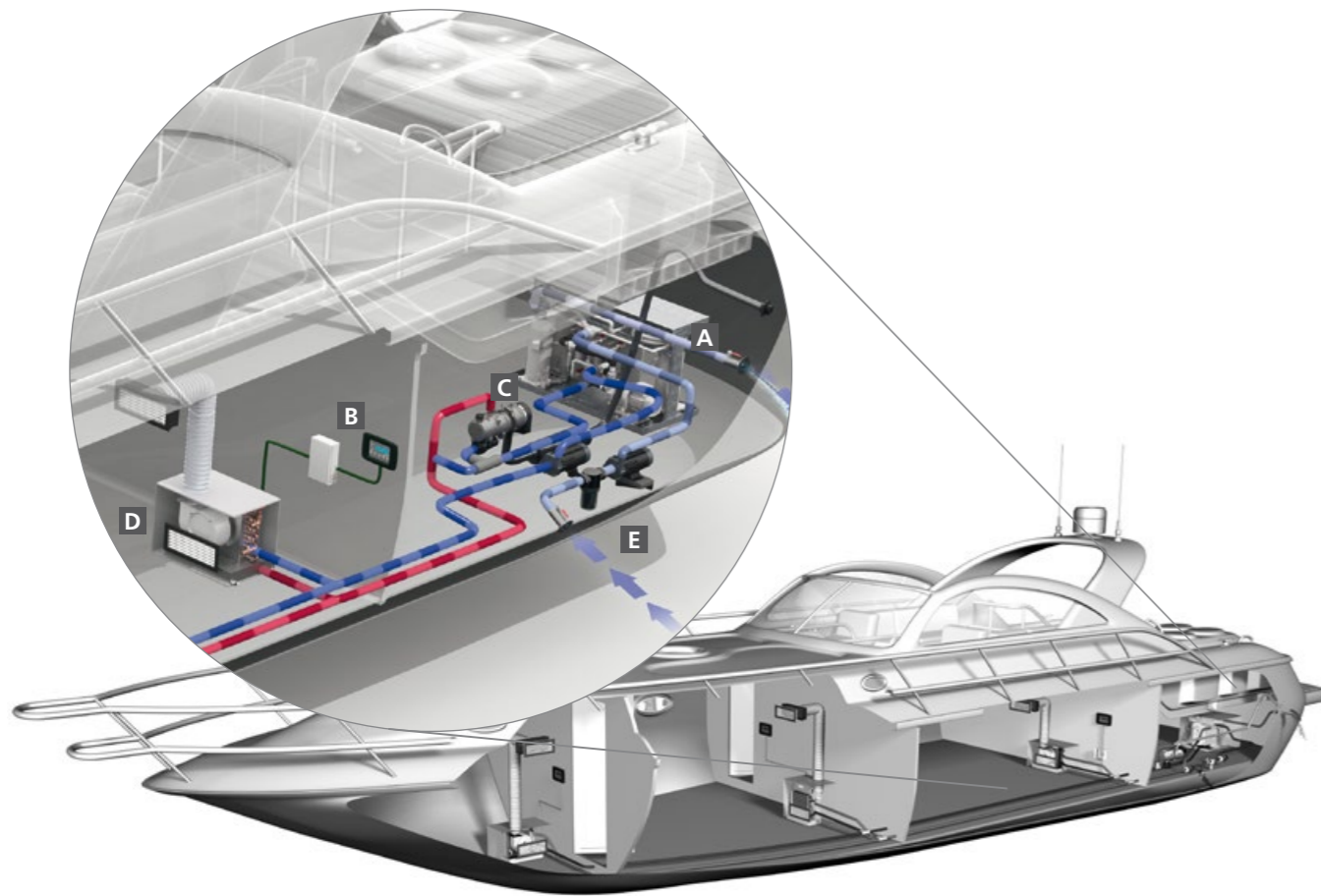

- A** Chiller A/C unit
- B** Cabin Control
- C** Heater
- D** Air Handler
- E** Sea Water Pump

BlueComfort Premium

Application Guidelines

For a complete BlueComfort Premium system, please combine the following:

1. Chiller air-conditioner

Core unit

Please select the core unit according to the required cooling capacity, the available voltage and whether cool only or heating via reverse cycle is needed.

- Air-conditioning unit [See page 102–117](#)

Position A as well as the following components are included in the scope of delivery:

- Electric cable and control box
- Operating manual
- Installation manual

Control elements for core unit

Please select the control elements for the core unit separately:

- MyTouch Display [See page 142](#)
- Display cable [See page 142](#)
- Remote air temperature sensor [See page 142](#)

Sea water circuit

Please order separately the components for the sea water circuit consisting of:

- Sea water inlet [See page 158](#)
- Sea water pump [See page 144](#)
- Overboard discharge [See page 158](#)
- Sea water strainer [See page 158](#)
- Closing valve [See page 157](#)
- Water hose [See page 157](#)

Chilled water circuit

Please add the required components for the chilled water circuit consisting of:

- Circulation pump [See page 144](#)
- 3-way valve (optional) [See page 157](#)
- Turn ball valve [See page 157](#)
- Piping or hosing system with insulation [See page 154](#)
- Expansion tank [See page 157](#)

Cabin accessories necessary for each single cabin

Please add for every single cabin the following components and accessories:

- Air handler [See page 126](#)
- Supply air grille [See page 150](#)
- Air ducting [See page 151](#)
- Transition box [See page 151](#)
- Water hoses for condensation drain [See page 157](#)
- Cabin control (Air control, display cable, temperature sensor and control box) [See page 142](#)
- Return air grille [See page 150](#)

2. Water Heater

Select the right heater according to the table below or more accurately as a result of the calculation in the specification tool.

Chiller air-conditioning cooling capacity						
BTU/h	12,000	24,000	32,000	40,000	48,000	60,000
kW	3.5	7.0	9.3	11.7	14.0	17.6
	Thermo Pro 50 Eco			Thermo Top Pro 120		
		Thermo Pro 90				Thermo Top Pro 150

BlueComfort Premium

Basic Integration

In a BlueComfort Premium system an A/C unit and a diesel-operated water heater are integrated into one system. The use of a water heater ensures full heating performance even at cooler sea water temperatures where the reverse cycle operation comes to its limits. In this integrated system the same water piping, air handlers, air ducting and cabin temperature control modules are used for both heating and A/C operation. For user friendliness, the main system is controlled via one control panel while each cabin has an individual temperature and blower speed control. The BlueComfort Premium system offers two integration options: the "Basic" and the "DeLuxe" integration depending on comfort requirements.

Basic Integration

The Basic integration is simply **integrating a water heater with a 3-way valve into the chilled water system.** The valve ensures that no cold water is running through the heater which would cause condensation. Both, the heater and the 3-way motor valve are controlled by the A/C electronic control. A special heater with a lower temperature setting or additional thermostats are needed in order to limit the water temperature to 60°C.

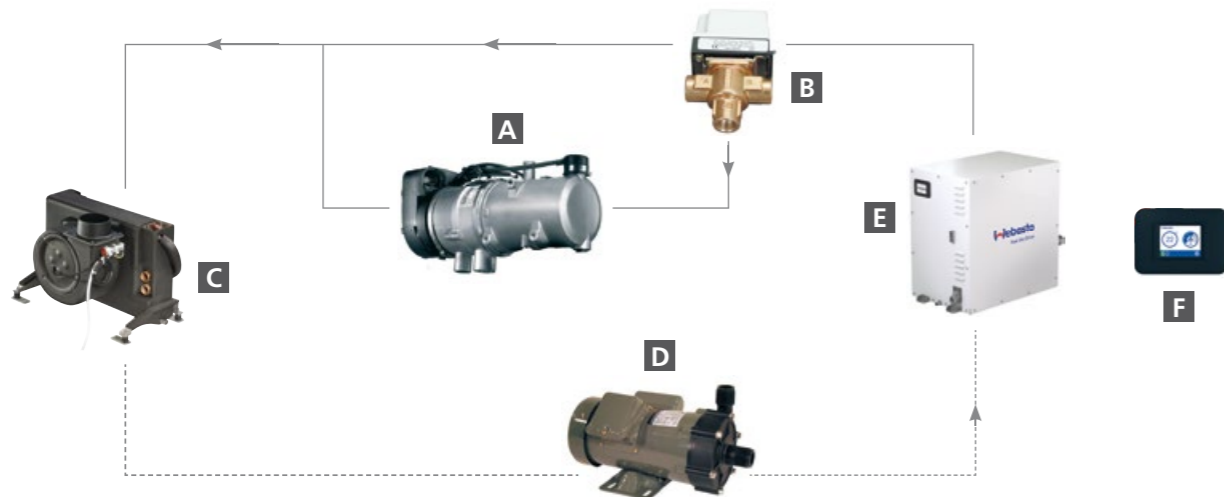

- A Water heater** Produces hot (60°C) water when system switches to heating
- B 3-way valve** Switches between cooling or heating loop
- C Air handler** Warms up or cools down returning air
- D Water pump** Circulates the water
- E A/C chiller unit** Cools down the water when system switches to cooling
- F Chiller control** Controls the complete A/C system and the water heater
Starts the compressor when cooling is necessary
Starts the heater when heating is necessary

BlueComfort Premium

DeLuxe Integration

The DeLuxe integration has all the features of the **Basic integration but additionally allows the integration of a water boiler as well as further fan blowers or radiators into the system.** It therefore provides the highest comfort in heating and sanitary water supply. The mixing valve limits the water temperature in the A/C loop to 60°C. A summer/winter switch allows heating of the boiler in summer while the A/C system is cooling the cabins at the same time.

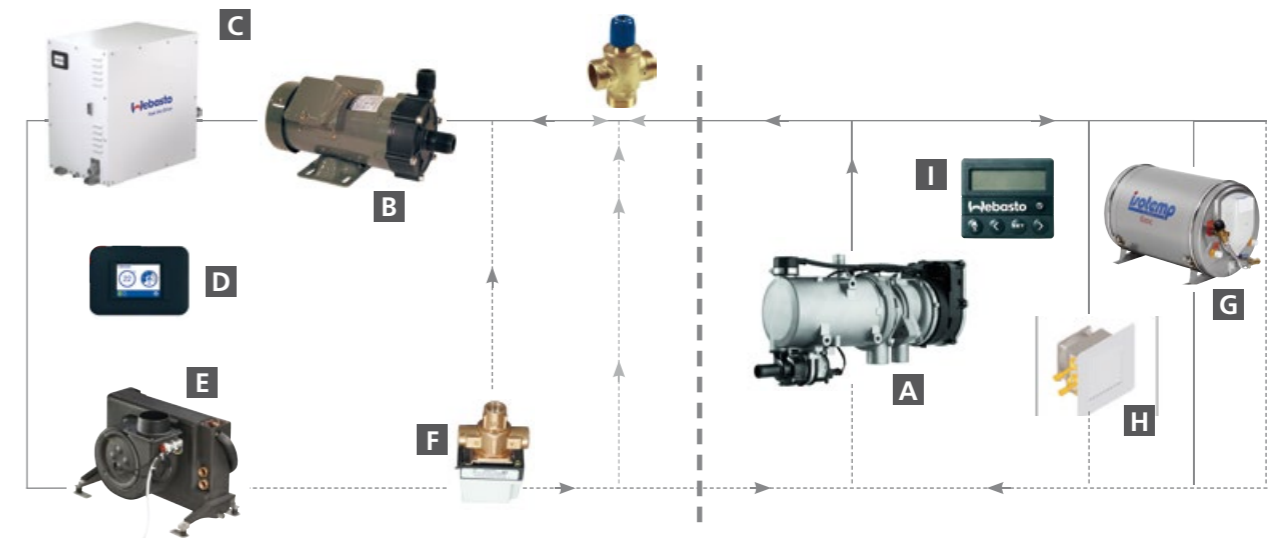

- A Water heater** Produces hot (approx. 80°C) water when system switches to heating
- B Water pump** Circulates the water
- C A/C chiller unit** Cools down the water when system switches to cooling
- D Chiller control** Controls the complete A/C system and the water heater
Starts the compressor when cooling is necessary
Starts the heater when heating is necessary
- E Air handler** Warms up or cools down returning air
- F 3-way valve** Switches between cooling or heating loop
- G Water boiler** Heats up the sanitary water
- H Blowers or radiators** can optionally be used in areas with extra high heating demand (e.g. windscreen for demisting)
- I Summer/Winter switch** Allows separate boiler operation in summer mode

For a perfect integration Webasto recommends Isotemp double coil boilers.
For more information visit: indelwebastomarine.com



Roof & Shading Solutions

Webasto Marine Roofs	172
A Roof Solution For Every Boat	174
BlueSky Sliding roof range	176
20-Series Specifications	178
40-Series Specifications	179
60-Series Specifications	180
80-/100-Series Specifications	181
The Finishing Touch – Custom Roof Blinds	182
Hercules Blind Customization Possibilities	183
New Marine Shading Solutions	184
Folding Shade 2500	184
Folding Shade 3500	184
Telescopic Shade 2500	186

Webasto Marine Roofs



Webasto offers a wide range of roof solutions, whether you are looking for a standard roof size with easy installation or a more customizable platform for your individual needs. As our customer you will additionally benefit from our technological leadership and knowledge brought over from our experience in the automotive sunroof industry.

Standard and Customizable Roof Solutions

Comfortable ready-to-go-platforms.

These are very economical solutions for more light and fresh air on board with a robust and proven construction. Our pre-mounted solution includes all necessary hardware allowing super quick and easy installation.

The BlueSky Range

Besides the electrical operated BlueSky, Webasto is also offering a manual version as well. The manual version is available in 2 sizes and offers the same quality and design features as the electrical operated version.

The electrical operated version is also available with a tempered glass panel and can be perfectly integrated in the design of the boat.

A Roof Solution For Every Boat

Roof References

The BlueSky



Innovative light weight sliding roof

The BlueSky sunroofs are designed for smaller boats and are now available in a number of variants. A choice can be made in terms of operation, dimension and panel type. The robust manual mechanism features a ventilation position and can be locked in any slide position.

- 2 sizes
- Electrical or manual operation
- Modern acrylic panel or flush glass panel
- High end interior finish
- Watertight sealing
- Robust and proven construction

The 20-Series



Economical and robust roof for more light on board

A very economical manual or electrical sliding roof for more light and fresh air on board. The roof is fully tested and pre-assembled including all necessary hardware allowing quick and easy installation.

- Standard roof with large opening
- Watertight sealing
- Robust and proven construction
- Manual or electrical operation
- Stepless locking system

The 40-Series



Standard electric marine sliding sunroof

This roof platform offers a sleek, low profile design to be able to fit in smaller boats. The roof is electrical operated, extremely quiet, and is delivered fully assembled, tested and ready to be installed.

- Attractive design with safety glass
- Watertight sealing
- Fast and simple installation
- Robust and quality-tested design
- Optional fixed glass panel for panoramic views

A Roof Solution For Every Boat

Roof References

The 60-Series



The easy, ready-to-be mounted solution

This series offers multiple customization options for a perfect fit. The roof is delivered fully tested, pre-assembled and ready-to-be-mounted at the shipyard thus resulting in significant cost saving for the boat builder.

- Customizable roof system
- Watertight sealing
- Robust and proven construction
- Electrical operation
- Smooth automotive style mechanism

The 80-Series



Economical and robust roof for more light on board

A completely dedicated roof solution whereby application engineering and a close cooperation with the shipyard is required. The roof is delivered fully tested, pre-assembled and ready-to-be-mounted.

- Fully integrated roof design
- Watertight sealing
- Very large dimensions and opening
- Selection of different panel materials
- Double curved solution is possible

The 100-Series



Roof design for extra large glass and composite panels

The 100 Series roof offers the same unique customization possibilities as the 80 Series. The mechanism is however upgraded to ensure perfect operation in combination with sliding panels up to 100 kg.

- Fully integrated roof design
- Watertight sealing
- Very large dimensions and opening
- Selection of different panel materials
- Double curved solution is possible



BlueSky – Unique Sliding Hatch

The BlueSky sunroofs are designed for smaller boats and are now available in several variants. A choice can be made in terms of operation, dimension and panel type.

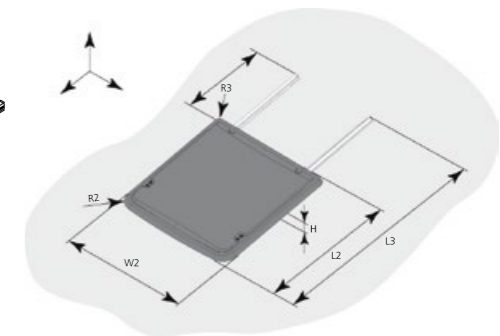
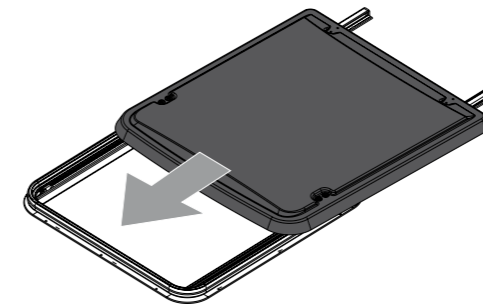

Electric operation

Thanks to the electrical operation the hatch is easy to use and the panel can be locked in any desired position. The tilting and sliding mechanism in combination with the seal ensures full water tightness.

Manual operation

Besides of the electrical operated BlueSky also a manual version is available. The manual version offers the same quality and design features as the electrical operated version. This version is a good alternative in those cases where a more economical solution is desired.

Acrylic panel

The acrylic panel is made from two acrylic shells with a screen print resulting in a modern design, light weight and improved insulation. This construction is unique in the marine industry.

Glass panel

Besides of the acrylic panel the electrical operated BlueSky can also be offered with a 6 mm grey tinted glass panel. This variant is the top end of the range and offers a flush integration in the boat design.

Cut-out size

Besides of the cut-out dimension 770 x 720 the BlueSky roof is now also available in a smaller size, 500 x 500. This variant is available in combination with manual operation and acrylic panel only. The styling of the product is similar to the 770 x 720 variant.

Black finish

Following the market trend, the BlueSky roofs are available in all black finish. This creates a more modern look and is in line with the black window pillars and frames.

Technical specifications

Description	BlueSky Range			
	Electric L770 W720 Glass	Electric L770 W720 Acrylic	Manual L770 W720 Acrylic	Manual L500 W500 Acrylic
Frame Material	Aluminium	Aluminium	Aluminium	Aluminium
Panel Material	6 mm Glass	2 x 3 mm Acrylic/Grey Tinted	2 x 3 mm Acrylic/Grey Tinted	2 x 3 mm Acrylic/Grey Tinted
Sliding rail material	Aluminium	Aluminium	Aluminium	Aluminium
Overall Dimensions (L3 x W2) (mm)	1,462 x 777	1,490 x 810	1,490 x 810	944 x 590
Cut-out Length (L1) (mm)	770	770	770	500
Cut-out Width (W1)	720	720	720	500
Corner radius (FRC, RCR) (mm)	65	65	65	65
Operation Mode	Electrical 12 VDC	Electrical 12 VDC	Manual	Manual
Opening Dimension (L x W) (mm)	508 x 642	483 x 642	456 x 684	192 x 464
Weight (kg)	approx. 19	approx. 14	approx. 11	approx. 8
Partnumbers	3398857A – Black Finish	3398587A – Black Finish	3398817A – Black Finish	3398818A – Black Finish

20-Series Specifications

One Fits All

Select options

- Sunblind/flyscreen
- Also electrical version available

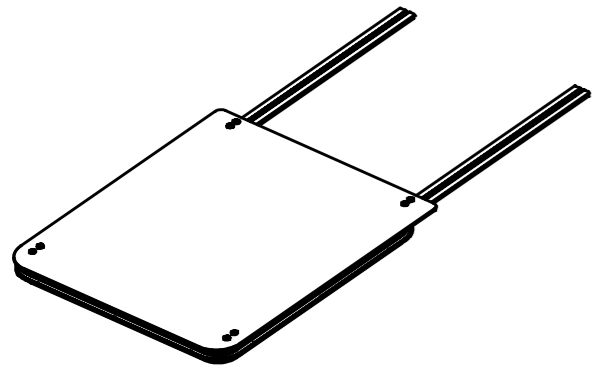

Technical specifications

	20-Series Manual	20-Series Electric
Frame material	Aluminum	
Panel material	8 mm tempered safety glass/grey tinted	
Sliding rail material	Aluminum	
Overall dimensions (mm)	1,995 x 1,010	
Cut-out length (L1) (mm)	1,010	
Cut-out width (W1) (mm)	955	
Corner radius (FRC, RCR) (mm)	80	
Operation mode	Manual, stepless locking	Electrical 12 VDC
Opening dimension (mm)	800 x 800	720 x 800
Weight (kg)	approx. 40	approx. 41

Technical specifications are subject to change without prior notice.

40-Series Specifications

A Perfect Fit

Select options

- Fixed panel
- Sunblind/flyscreen
- Motor cover

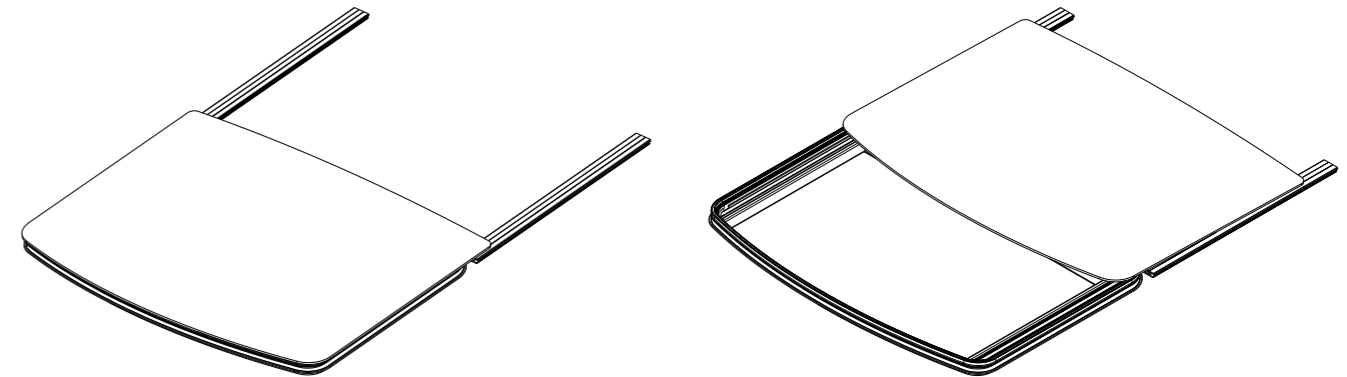

Technical specifications

	40-Series
Frame material	Aluminum
Panel material	8 mm tempered safety glass/grey tinted
Sliding rail material	Aluminum
Overall dimensions (mm)	1,665 x 1,379 (1,865 x 1,379 with fixed panel)
Cut-out length (L1) (mm)	915
Cut-out width (W1) (mm)	1,320
Corner radius (FRC, RCR) (mm)	80
Cross radius (R2) (mm)	7,620
Front radius (R3) (mm)	2,032
Operation mode	Electrical 12 V DC
Opening dimension (mm)	624 x 1,172
Weight (kg)	approx. 45

Technical specifications are subject to change without prior notice.

60-Series Customization Possibilities

5 steps to customize your roof

- 1** Select roof type:
 - Top mount
 - Flush integrated
- 2** Define dimensions:
 - Length
 - Width
 - Curvature
- 3** Select panel design:
 - Acrylic
 - Glass
 - Sandwich
- 4** Select frame finish:
 - Anodizing
 - Powder coating
- 5** Select options:
 - Motor cover
 - Fixed panel
 - Sunblind/flyscreen
 - 24 V DC (12 V DC is standard)

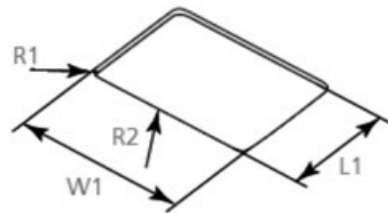
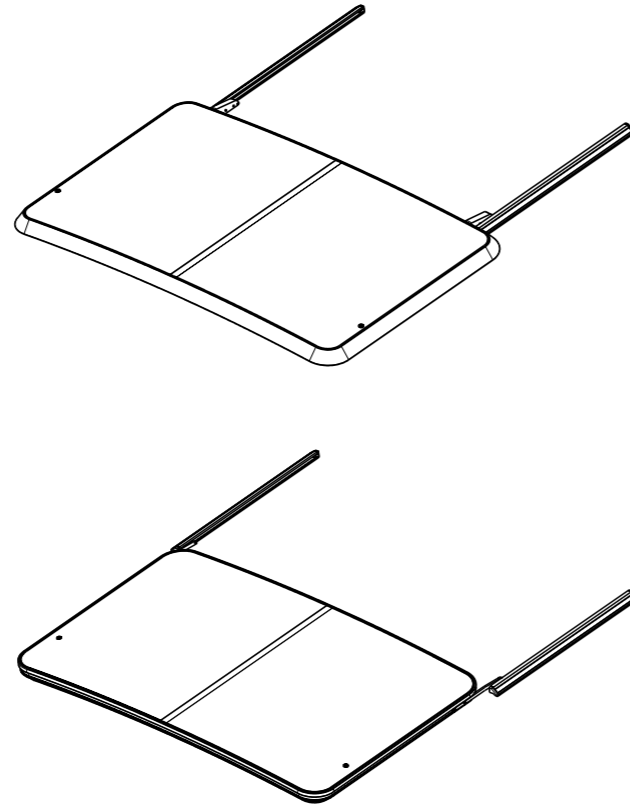

Figure 1

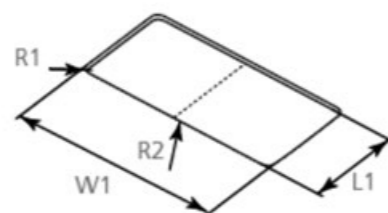

Figure 2

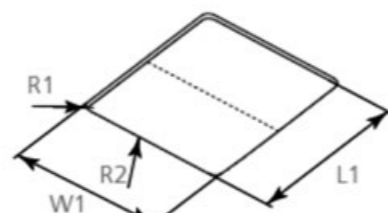

Figure 3

Technical specifications

Maximum cut-out size dimensions for our customized roofs		Max. length L1 (mm)	Max. width W1 (mm)	Corner curvature R1 (mm)	Min. cross curvature R2 (mm)
Figure 1	Roof without cross beam	1,100	1,100	80	7,500
Figure 2	Roof with cross beam in sliding direction	1,100	1,800	80	7,500
Figure 3	Roof with cross beam perpendicular to sliding direction	1,500	1,100	80	7,500

80-/100-Series Customization Possibilities

5 steps to customize your roof

- 1** Select panel design:
 - Glass
 - GRP
 - Sandwich
- 2** Select roof shape:
 - Square
 - D-shape
- 3** Define dimensions:
 - Length
 - Width
 - Curvatures
- 4** Select design:
 - Glass color
 - Frame color
- 5** Select options:
 - Fixed panel
 - Sunblind/flyscreen
 - 24 V DC (12 V DC is standard)

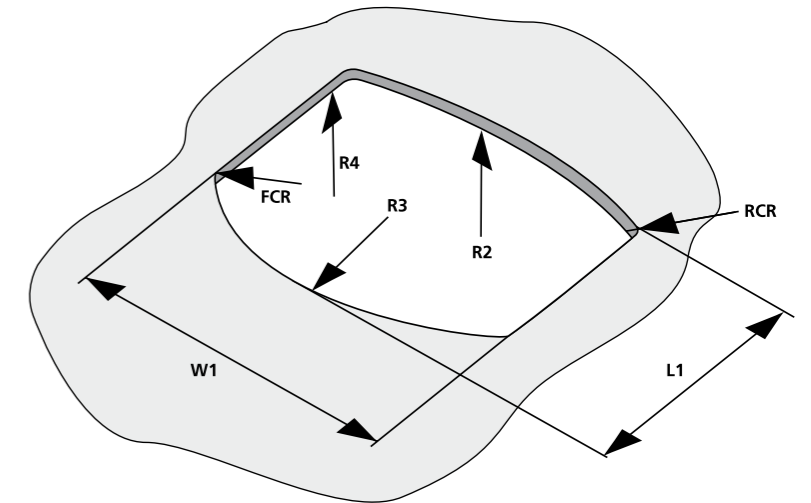

Technical specifications

Dimension code	Description	Glass	GRP	Sandwich
W1	Maximum width	2,750	2,750	2,750
L1	Maximum length	1,900	2,400	1,900
R2	Minimum cross radius	7,500	7,500	7,500
R3	Minimum front radius	2,500	2,500	2,500
R4	Minimum length radius	N.A.	5,000	N.A.
FCR	Front corner radius	Mitred or R = 80	Mitred or R = 80	Mitred or R = 80
RCR	Rear corner radius	Mitred or R = 80	Mitred or R = 80	Mitred or R = 80

Remark: All dimensions are in mm
 Maximum dimension of glass and GRP panel is defined by maximum weight of 80/100 kg
 Glass panel and Sandwich panel only have a cross radius (single bended)
 Glass panel and Sandwich panel have fixed radius of: 7,500; 10,000; 15,000; 30,000 mm

The Finishing Touch – Custom Roof Blinds



Sky screen pleated for 20-Series

- Perfect fit: Dedicated dimension for 20-Series
- Integrated flyscreen: Allows for cabin ventilation whilst keeping the insects out.
- UV protection: Essential overhead shading from direct sunlight, providing energy efficient light and temperature control.
- Quick and easy to install: Pre-assembled, surface mount, robust aluminium frame with concealed mounting holes.

Hercules blind

- Robust: Use of intermediate bars leaves for a cordless and safe open aperture.
- Large dimensions: Designed to complement Webasto's wide range of roof systems.
- Integrated flyscreen: Allows for cabin ventilation whilst keeping the insects out.
- UV protection: Essential overhead shading from direct sunlight, providing energy efficient light and temperature control.
- Fully customizable: System is offered in various configuration possibilities and colours.
- Quick and easy to install: Full frame system, pre-assembled before installation (optional).

Hercules Blind Customization Possibilities

Three steps to customize your blind

- 1 Select frame design:**
 - Blind & flyscreen – Double ended
 - Blind & flyscreen – Single ended
 - Blind only – Single ended
 - Flyscreen only – Single ended
- 2 Select fabric colour:**
 - White
 - Ivory
 - Straw
 - Beige
- 3 Define dimensions:**
 - Drop (max. 2,800 mm)
 - Width (max. 2,400 mm)
 - Curvature (min. 7,500 mm)

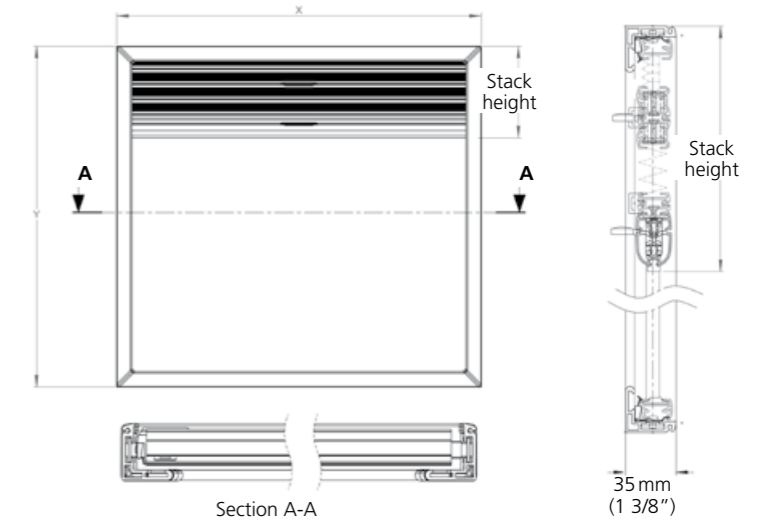

Marine Shading Solutions

Folding Shade 2500/3500

Perfect Shelter for Sunny Days On the Water



Benefiting from over 15 years of experience in marine roof systems, Webasto is offering their newly developed Marine Shading Solutions Range. With the Folding Shade & Telescopic Shade System, Webasto provides the perfect shelter for sunny days on the water.

The systems are designed for the use above the cockpit, rear deck or fly bridge and can be operated with the touch of a button. Thanks to the smart and straight forward designs the products are easy to customize ensuring a perfect match with the styling of the boat.



Technical Highlights Folding Shade:

- For application above cockpit, rear deck or fly bridge
- Smart & customizable design to perfectly match the style of the boat
- Easy to use, operation of the system by the touch of a button
- Folding Shade 2500: sliding and folding
- Folding Shade 3500: sliding and folding
- Based on automotive kinematics and drive systems
- Tension & locking system for tensioning the fabric
- Self-adjusting cross beam fixation to cope with installation tolerances

Marine Shading Solutions

Folding Shade 2500/3500

Technical data

General	Folding Shade 2500	Folding Shade 3500
Description		
Operation	Electric with Rocker switch	Electric with Rocker switch
Operation voltage	12 VDC	12 VDC
Installation method	Installation method Rails, cross beam & fabric are screwed and mounted from the top. Drive system screwed from the bottom.	Installation method Rails, cross beam & fabric are screwed and mounted from the top. Drive system screwed from the bottom.
Materials used	Materials used Rails and crossed beams are aluminium, anodized. Sliders are plastic and stainless steel.	Materials used Rails and crossed beams are aluminium, anodized. Sliders are plastic and stainless steel.
Fabric material outside	Sunbrella, type: Plus, different colors possible	Sunbrella, type: Plus, different colors possible
Fabric material inside	Dickson, type: Velum, different colors possible	N.A.
Allowable temperature (°C)	-10 to +75	-10 to +75
Dimensions		
L1 Length (mm)	Maximum outside dimension is: 2,750	Maximum outside dimension is: 5,000
W1 Width (mm)	Maximum outside dimension is: 2,500	Maximum outside dimension is: 3,500
Longitudinal curvature (mm)	Minimal 20,000 to Straight	Minimal 20,000 to Straight
Cross curvature (mm)	Minimal 10,000 to 25,000	Minimal 10,000 to 25,000
Remark	Remark Curvature combination between longitudinal and cross direction to be evaluated per application	Remark Curvature combination between longitudinal and cross direction to be evaluated per application



Folding Shade 2500



Marine Shading Solutions

Telescopic Shade 2500



Extend your time on the water

Developed to keep you protected from the sun and extend your day on the water, the Webasto Telescopic Shade is the newest addition to Webasto's impressive, market-leading marine roof line up.

Our electric-powered retractable sunshade creates the perfect canopy for passengers, while ensuring a smooth and robust operation that can be enjoyed both while anchored or motoring. It can also be installed in tandem with one of our other roof systems. The Telescopic Shade system is an excellent solution for creating additional on-board comfort.

For an optimal fit on the boat, the Telescopic Shade can be ordered to specific dimensions up to a fabric width of 8 feet (2,500 mm). There are also four trend fabric colors to choose from, with additional colors available.

The overall design, in combination with the high-gloss polished stainless-steel tubes and Marine-grade material, makes this a true marine solution.

Product Features:

- Fully retractable and customizable widths up to 8 feet (2,500 mm)
- Self adjusting within 5 mm
- Marine-grade stainless steel tubing
- High-quality, eco-friendly shade fabric
- Easy installation
- Easily retrofitted or integrated by boat builders
- Options for any style or size boat (with an overhead structure)
- Patent pending

Marine Shading Solutions

Telescopic Shade 2500

Technical data

	Telescopic Shade 2500
Telescope and cross beams material	High gloss polished stainless steel
Fabric material	Marine grade, Glen Raven/Dickson infinity
Fixation brackets material	(High gloss polished) Cast Stainless steel
Plastic covers	High grade UV-resistant PA6
Maximum system dimensions (W x L)	110 in x 140 in (2,800 mm x 3,560 mm)
Maximum fabric dimensions (W x L)	98 in x 78.7 in (2,500 mm x 2,000 mm)
Telescope tube diameters	1.9 in/2.3 in/2.7 in (50 mm/60 mm/70 mm)
Cross beam diameter	1.2 in (30 mm)
Cross beam adjustment (mm)	Self adjusting, Y, +/-5
Fixation bracket adjustment (mm)	Adjustable, X,Y,Z, +/-5
Drive system	Tube drive, 12 VDC
Spring system	Stainless steel gas spring with extra oil chamber
Weight	110 lbs (50 kg)



High-quality, eco-friendly shade fabric

- UV-, fade- and tear-resistant
- Optimal durability among extreme conditions
- Dry-quick material resists mold
- Easy to clean
- Four fabric colors options (additional color options available)

The development of the Telescopic Shade 2500 focused on the ease of installation, which is done in only a few simple steps. The base tubes are fixed to the boat with adjustable mounting brackets, while the stainless steel cross beams are self-adjusting, minimizing stress on the system.

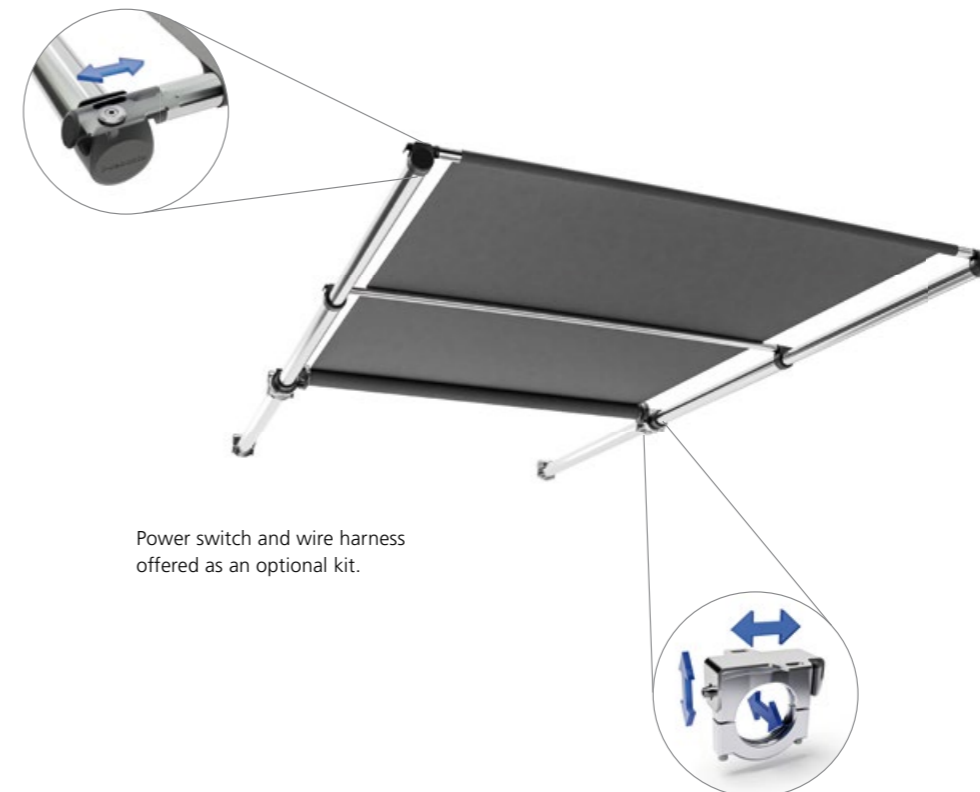

Power switch and wire harness offered as an optional kit.



Nomenclature

In order to define descriptive technical abbreviations for our air-conditioner and our air handler units, Webasto introduced a special nomenclature for the price list.

Air-conditioning units nomenclature

Air-conditioning model abbreviations:

C = Chiller (BlueCool C-Series)

Example: C55T-R-230V-REV-R410A = Chiller 55,000 Twin Rotary compressor 230 V reversible refrigerant R410A

C	55	T	-R	-230 V	-REV	-R410A
C-Series	55,000 BTU/h	Twin	Rotary comp	Voltage	REV = reverse cycle	refrigerant

S = Self-Contained (BlueCool S-Series)

Example: S6-R-230V-REV-R410a = Self-Contained 6,000 230 V reversible

S	6	-R	-230 V	-REV	-R410A
Selfcontained	6,000 BTU/h	Rotary compressor	Voltage	REV = reverse cycle	refrigerant

P = Professional Chiller (BlueCool P-Series)

Example: P60M-S-400V-REV-R407C = P-Series Chiller 60,000 Mono Scroll 400 V reversible refrigerant R407C

P	60	M	-S	-400 V	-REV	-R407C
P-Series 60,000 BTU/h	Mono	S = Scroll comp.		Voltage	REV = reverse cycle	refrigerant

A = Air handler (BlueCool A-Series)

Example: A12 Compact -230V -50/60Hz = A-Series Air handler Compact type 12,000 kBTU/h 230 V; 50 Hz and 60 Hz

A	12	Compact	-230 V	-50/60 Hz
A-Series	12,000 BTU/h	Compact type	Voltage	Frequency

Webasto subsidiaries and representatives

Head Office

Webasto Thermo & Comfort SE

Friedrichshafener Straße 9
82205 Gilching
Phone: +49 (0) 89 85794-0
www.webasto.com

Argentina

FRIBA TECNOLOGÍA S.A.

Av. Pavón 4080/84
C1253AAY Buenos Aires
Phone: +54 11 49242117
www.friba.com.ar

Australia

Webasto Thermo & Comfort

Australia Pty. Ltd.
423-427 The Boulevarde
NSW 2232 Kirrawee
Phone: +61 2 85364800
www.webasto.com.au

Austria

Webasto Fahrzeugtechnik G.m.b.H.

Jochen-Rindt-Straße 19
1230 Vienna
Phone: +43 1 6043780
www.webasto.at

Belarus

Falkat GmbH

Ul. Drozda 8
220004 Minsk
Phone: +375 17 2001894
www.falkat.com

Benelux

Webasto Thermo & Comfort Benelux B.V.

Constructieweg 47
8263 BC Kampen
Phone: +31 38 3371137
www.webasto.nl

Brazil

ACA – Ar Condicionado Automotivo

661, R. Henrique Gonzaga de Souza
Neto
Guatupê, São José dos Pinhais
PR, 83060-460, Brazil
Phone: +55 41 3098-8686
www.aca.ind.br

Bulgaria

Rhea MP GmbH

ul. Boris Iliev 17
1839 Sofia
Phone: +359 2 9420555
www.rheamp.com

China

Webasto Thermo & Comfort Technology (Beijing) Co. Ltd.

A 2105, Building 2,
Boya International Center
No. 1 Lize Zhongyi Road
Chaoyang District
100102 Beijing
Phone: +86 10 84782320
www.webasto.cn

Czech Republic

Webasto Fahrzeugtechnik Gesellschaft m.b.H.,

odšt pný závod
U Elektry 830/2b
198 00 Praha 9
Phone: +420 241045462
www.webasto.cz

Denmark

Webasto Thermo & Comfort Denmark A/S

Islevdalvej 180
2610 Rødovre/Copenhagen
Phone: +45 44522000
www.webasto.dk

Estonia

AS KG KNUTSSON

Saeveski 12
11214 Tallinn
Phone: +372 6 519300
www.kgk.ee

Finland

Oy Kaha AB

Ansatie 2
01740 Vantaa
Phone: +358 9 61568379
www.kaha.fi

France

Webasto Thermo & Comfort

France S.A.S.

PA Estuaire Sud
Rue du Camp d'Aviation
44320 Saint Viaud
Phone: +33 (0) 1 69 13 84 00
www.webasto-france.fr

Germany

Webasto Thermo & Comfort SE

Friedrichshafener Straße 9
82205 Gilching
Phone: +49 (0) 395 5592-229
www.webasto.de

Great Britain

Webasto Thermo & Comfort UK Ltd.

White Rose Way
South Yorkshire
Doncaster DN4 5JH
Phone: +44 (0) 1302 322232
www.webasto.co.uk

Webasto subsidiaries and representatives

Greece

SYSTEMS S.A.

73rd, Agias Annis street
18233 Rentis
Phone: +30 210 3472105
www.systemssa.gr

Hungary

Fahrzeugtechnik

Gesellschaft m.b.H.

Magyarországi Fióktelepe
Madarász Viktor u.
47-49. 1-703C
1138 Budapest
www.webasto.hu

Iceland

Bilasmidurinn hf.

Bíldshofda 16
110 Reykjavík
Phone: +354 5672330
www.bilasmidurinn.is

India

Webasto Roofsystems

India Pvt. Ltd.

Ghat 838/1, Pune Nagar Highway
District: Sanaswadi
412208 Pune
Phone: +91 2137619902
www.webasto.com

Italy

Webasto Thermo & Comfort

Italy S.r.L.

Via Efrem Nobili 2
40062 Molinella (BO)
Phone: +39 051 6906 248
www.webasto.it

Japan

Webasto Thermo & Comfort

Japan Co. Ltd.

3-19-5 Shin-Yokohama Kohoku-ku
Kanagawa Prefecture
222-0033 Yokohama
Phone: +81 45 4741761
www.webasto.co.jp

Kazakhstan

Autootopitel KZ

Zhanazhol 19
010000 Astana
Phone: +7 7171576000
webasto@autootopitel.kz

Latvia

KG Knutsson SIA

Gunara Astras iela 3
1084 Riga
Phone: +371 67 807 870
www.webasto.lv

Lithuania

UAB KG Knutsson

Jocioniu g. 14
02300 Vilnius
Phone: +370 5 275 81 81
www.kgk.lt

Moldavia –

via Webasto Fahrzeugtechnik

Gesellschaft m.b.H.

Viena Sucursala (BUCURESTI)

Sos Odai, nr.40
075100 Otopeni, Ilfov
Phone: +40 21 2032751
www.webasto.ro

Mongolia – via Webasto China

Webasto Thermo & Comfort Technology (Beijing) Co. Ltd.

A 2105, Building 2,
Boya International Center
No. 1 Lize Zhongyi Road
Chaoyang District
100102 Beijing
Phone: +86 10 84782320
www.webasto.cn

Netherlands

Webasto Thermo & Comfort Benelux B.V.

Constructieweg 47
8263 BC Kampen
Phone: +31 38 3371137
www.webasto.nl

Norway

Webasto Thermo & Comfort Norway

Industriveien 34A
2072 Dal
Phone: +47 61162000
www.webasto.no

Poland

Webasto Petemar Sp. z.o.o.

ul. Warszawska 205/219
05-092 Lomianki
Phone: +48 22 7327320
www.webasto.pl

Romania

Webasto Fahrzeugtechnik Gesellschaft m.b.H.

Viena Sucursala (BUCURESTI)

Sos Odai, nr.40
075100 Otopeni, Ilfov
Phone: +40 21 2032751
www.webasto.ro

Webasto subsidiaries and representatives

Slovakia

Webasto Fahrzeugtechnik Gesellschaft m.b.H.,

organizačná zložka
Moldavská cesta 10/B
040 11 Kosice
www.webasto.sk

Slovenia

Webasto Fahrzeugtechnik Gesellschaft m.b.H.,

Podružnica v Sloveniji
Tržaška cesta 315
1000 Ljubljana
Phone: +386 1 2008712
www.webasto.si

South Korea

Webasto Customized Solutions Korea Ltd.

Indeogwon IT Valley,
40 Imi-ro, Bldg. B, Suite 612
16006 Uiwang-si, Gyeonggi-do
Phone: +82 31 80170241
www.webasto.kr

Spain

Webasto Thermo & Comfort Ibérica S.L.U.

C/Mar Tirreno 33
Polígono Industrial
28830 San Fernando de Henares
(Madrid)
Phone: +34 91 626 86 11
www.webasto.es

Sweden

KG Knutsson AB

Hammarbacken 8
19181 Sollentuna. Stockholm
Phone: +46 8 923000
www.kgk.se

Turkey

Webasto Thermo Comfort İklimlendirme Sistemleri Ticaret Limited Şirketi

Manisa Organize Sanayi Boelgesi 4.
Kısım
Ahmet Nazif Zorlu Bulvarı No: 8
45030 Manisa
Phone: +90 236 226 90 00
www.webasto.com.tr

USA

Webasto Thermo & Comfort North America Inc.

15083 North Road
FENTON MI 48430-1384
Phone: +1 810 593 5902
www.webasto.us

Ukraine

Thermo Projects Ukraine LLC

Nezalezhnosti boulevard, 20
07400, Brovary, Ukraine
Phone: +38 (044) 503-31-76
www.webasto.com/ua

Abbreviations

Specifications

ECE	Economic Commission for Europe
EMC	Electromagnetic compatibility
HDD	Heavy Duty Design
HTM	Heating time management
IK	Installation kit
SOD	Scope of delivery

Units of measurement

D	Diameter (mm)
Da	Outer diameter (mm)
Di	Inner diameter (mm)
H	Height (mm)
kg	Kilogram
L	Length (mm)
m	Meter
mm	Millimeter
r	Radius (mm)
SW	Wrench size (mm)
W	Width (mm)

Electrical units

A	Ampere
kW	Kilowatt
rpm	Revolutions per minute
V	Volt
W	Watt

Materials and fuels

APK	Aluminium paper plastic
EPDM	Ethylene propylene terpolymer rubber
FAME	Fatty acid methyl ester (fuel)
GA-A	Aluminium foil and aluminium coated glass fabric
GA2-A	Aluminium and aluminium coated glass fabric
H-M-A	Hard aluminium – plastic – aluminium
PA	Polyamide
PAK	Paper – aluminium – plastic
PAPK	Paper – aluminium – paper – plastic
TPE	Thermoplastic elastomer
VOME-	
resistant:	Resistant against various diesel-like fuels; B7, B10, XTL, etc.

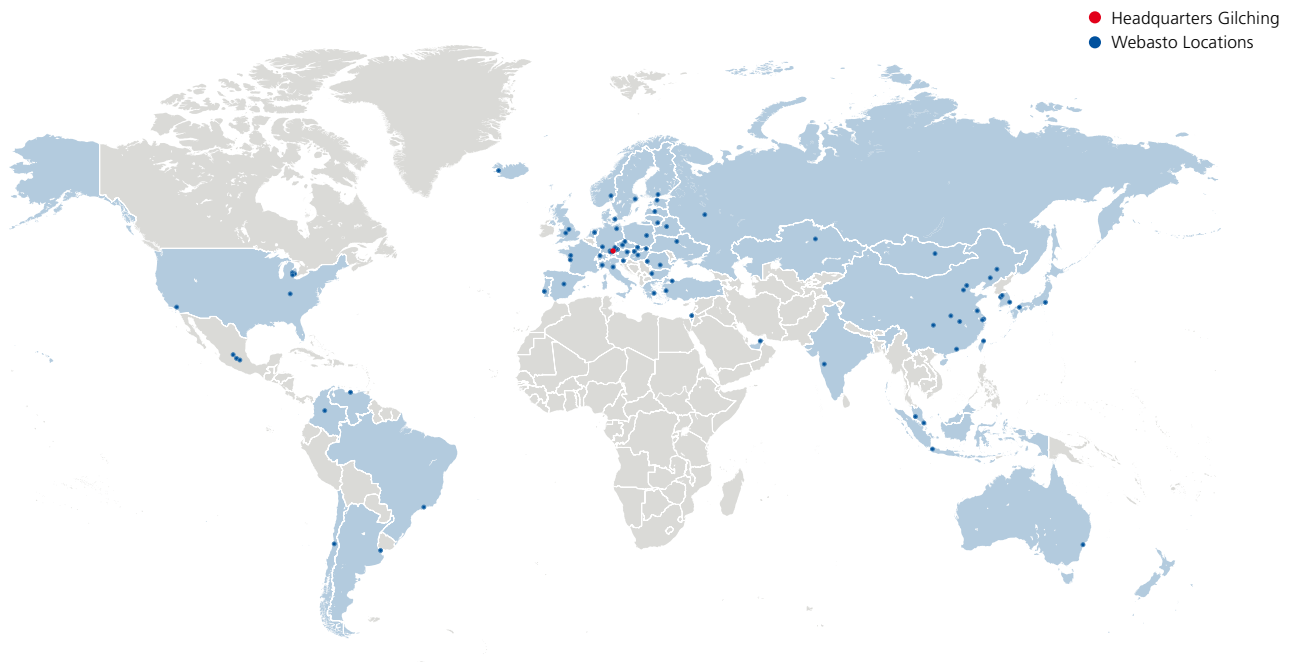

The Webasto Group is a global innovative systems partner to the mobility industry and one of the 100 largest suppliers to the automotive sector worldwide. The company's offering includes in-house developed roof, heating and cooling systems for various types of vehicles, batteries and charging solutions for hybrid and electric vehicles, and additional services related to thermal management and electromobility. Among the customers of Webasto are manufacturers of passenger cars, commercial vehicles and boats, as well as dealers and end customers. In 2021, the Group generated sales of 3.7 billion euros and employed around 15,700 people at over 50 locations. The headquarters of the company, which was founded in 1901, is located in Stockdorf near Munich (Germany). For more information please visit www.webasto-group.com