

15V 4213

Ford Ranger; Md. 2016

EU-Pedestrian Protection Bar 76 mm with cross pipe 51 mm

EU-Personenschutzbügel 76 mm mit Querrohr 51 mm

Protection avant, homologuée CEE, 76 mm, traverse 51 mm

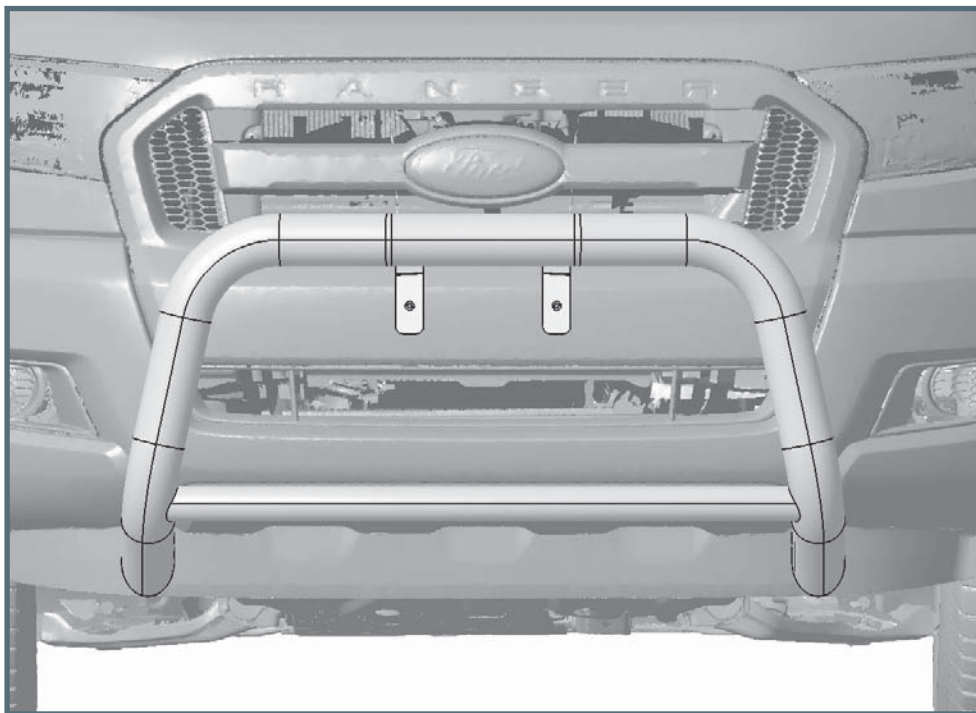

ASSEMBLY INSTRUCTION

Montageanleitung • Instructions de montage



35 Minuten

Artikel-Nr:
15V4213 stainless steel
15V5213 black steel

Revision 1: 22.09.2016

www.antec-online.de

M6:
10Nm
M8(A2):
21,4Nm
M8:
25Nm



4
5

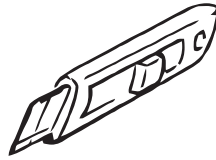

13

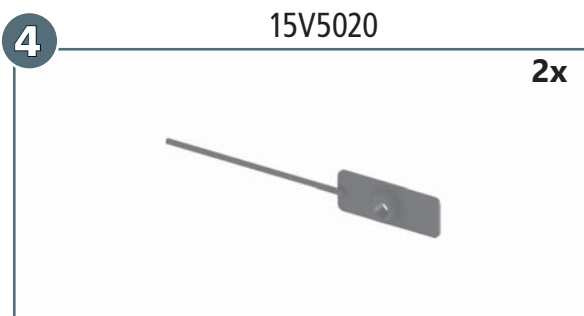
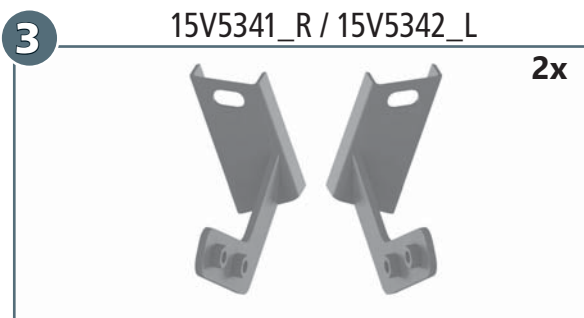
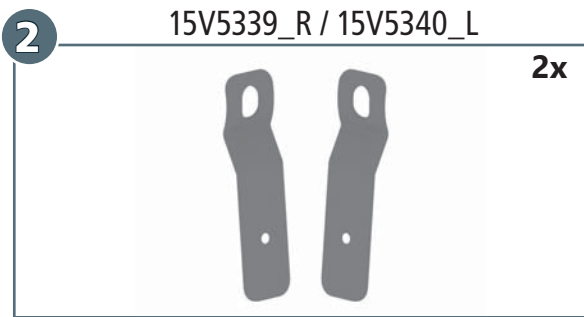

a		M6 x 30; DIN 7991 Zn	2x
b		M8 x 30; ähnl. ISO 7380 A2	4x
c		M8 x 25; DIN 933 Zn	2x
d		M8 x 30; DIN 933 A2	2x
e		Ø 4,8 x 19 mm; DIN 7981 A2	4x
f		Ø 8; DIN 127 Zn	2x
g		Ø 8; DIN 127 A2	2x
h		Ø 5,3; DIN 9021 A2	4x
i		Ø 8,4; DIN 9021 Zn	2x
j		Ø 8,4; DIN 9021 A2	2x
k		SW 13	2x

