

CLASSIC BUS HEATER

THERMO E

200 / 320



STATE-OF-THE-ART SYSTEM WITH A SOUND HERITAGE

Valeo Thermo E heaters were developed primarily for markets in which high performance levels and durability are essential. The result is a modern and extremely reliable product line based on many years of experience and successful predecessor models.

HIGHLIGHTS



Low life-cycle costs

- Simple maintenance with diagnosis via blink code
- Optimised heat exchanger guarantees high degree of efficiency and low fuel consumption



Environmentally friendly

- Low emission values (significantly below legal limits)



Comfort

- Integral control unit with waterproof connectors for a high degree of reliability
- 20 and 32 kW versions cover performance requirements of all applications

Thermo E installation dimensions

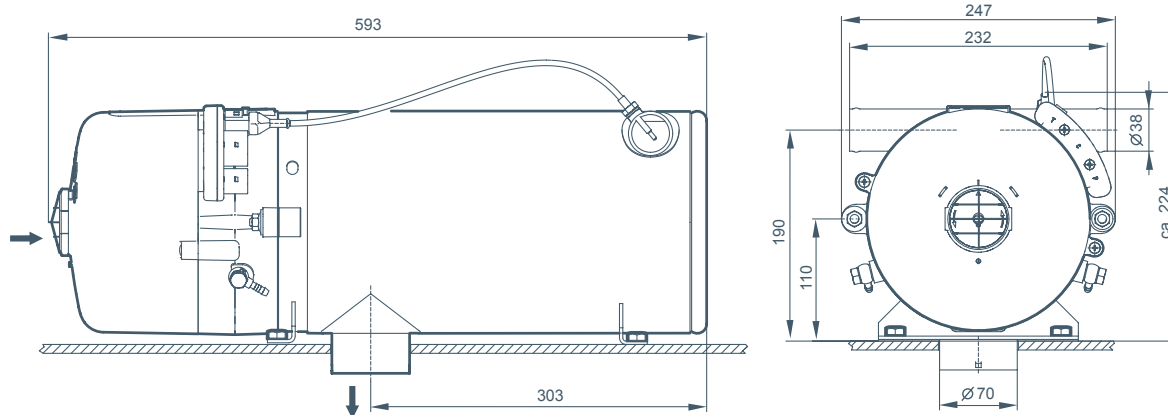

TECHNICAL DATA

	Thermo E 200	Thermo E 320
Heat output (kW)	20	32
Electr. power consumption (W)	55	100
Fuel consumption (l/h)	2.7	4.1
Rated voltage (V)	24	24
Dimensions L x W x H (mm)	593 x 247 x 224	593 x 247 x 224
Weight (kg)	17	17