

050-0700
12mm Single
Rotor Latch



This compact single rotor latch is designed for use on light to medium duty operator and compartment doors for on or off-highway applications. There are a number of variants allowing it to interface with TriMark's range of external and internal methods of activation for application flexibility.

- Operator and compartment door applications for on and off-highway vehicles
- Light to medium duty doors up to 25 kg (55 lbs.) with door seal pressures no greater than 20 kg (44 lbs.)
- Use with TriMark 070-0400 Striker Bolt

FEATURES/BENEFITS:

- Compact size and shape; allows maximum visibility and use of door space
- Four standard variants; provides application flexibility
- Black finish reduces the need for secondary painting or covers



www.trimarkcorp.com

TriMark Corporation
500 Bailey Avenue
P.O. Box 350
New Hampton, Iowa 50659
United States
Tel: 641-394-3188
Fax: 641-394-2392
1-800-447-0343
www.trimarkcorp.com

TriMark Europe
Cedar Court
Walker Road
Bardon Hill
Coalville LE67 1TU
United Kingdom
Tel: +44(0)1530 512460
Fax: +44(0)1530 512461
www.trimarkeu.com

AVAILABLE:

- Versions are available to allow direct or remote actuation from exterior handles and interior release
- Standard left and right hand versions; allows use in either orientation (right hand shown)
- Standard M8 X 1.25 threaded axles as shown or 8.4mm diameter "thru" axles

FINISH:

- Zinc plated steel components with black finish

MATERIAL:

- Rotor: Heat treated steel
- Case halves: High strength steel
- Springs: Non-corrosive stainless steel
- Inside release knob: Die cast zinc alloy
- Push button bellcrank: die cast zinc alloy

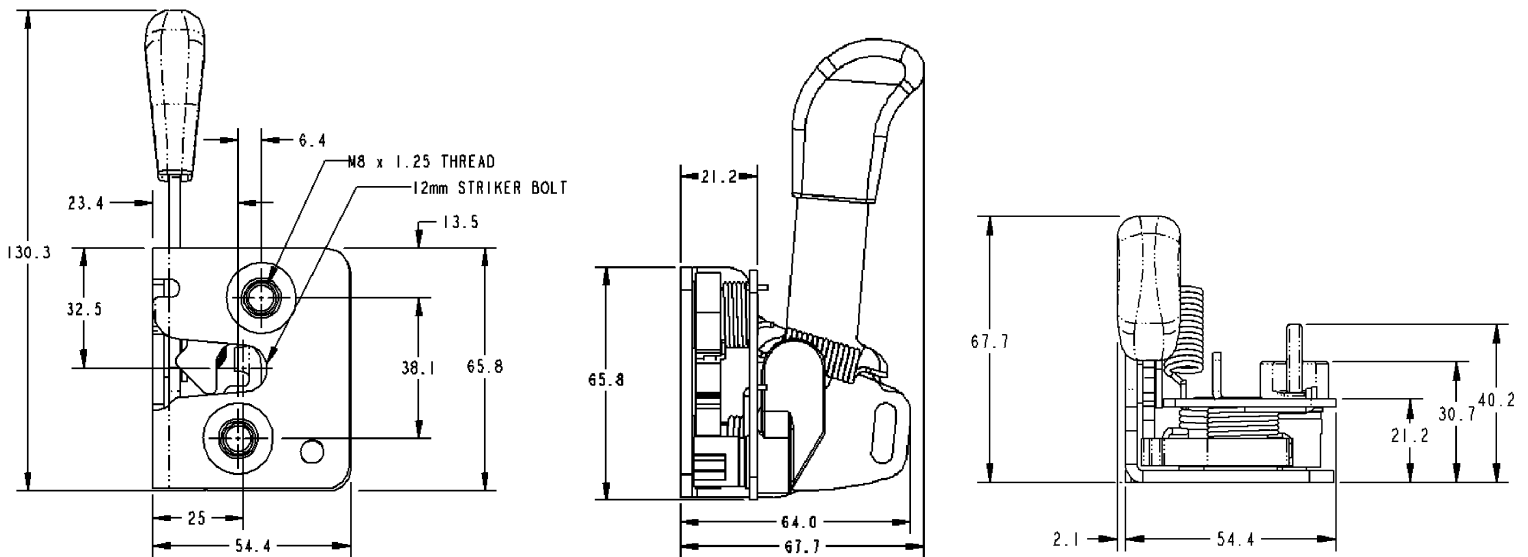

Direct Push Button / Remote Inside Release

The Direct Push Button / Remote Inside Release version features an integrated bellcrank for direct push button handle release and a separate remote inside release for application flexibility.

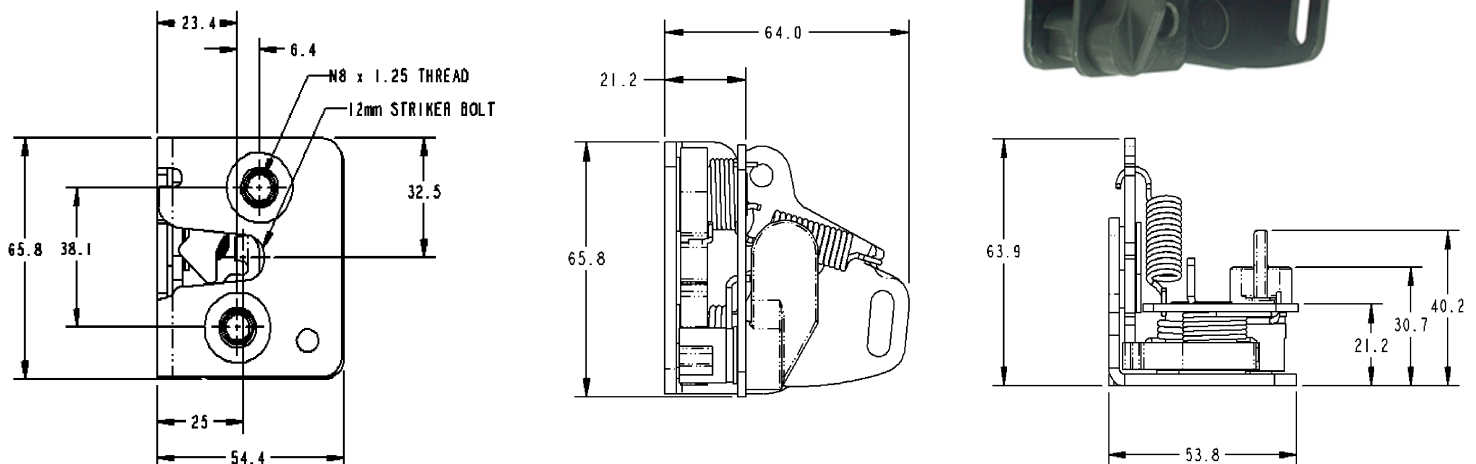

INSTALLATION:

- M8 X 1.25 threaded axles; provides ease of installation (Tighten to the fastener manufacturers' recommended torque value)

CAUTION: Product does not meet the locking requirements for FMVSS 206.

Individual part dimensions are for reference only. Refer to individual part drawings for complete dimensions, specifications, and installation procedures. Engineering assistance and application drawings are available.

Remote Exterior / On-Latch Inside Release

The Remote Exterior / On-Latch Inside Release version features an on-latch inside release lever with provision for remote exterior release for application flexibility.

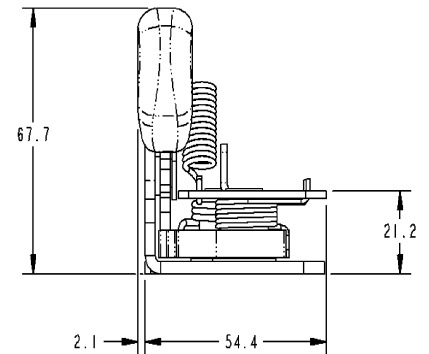
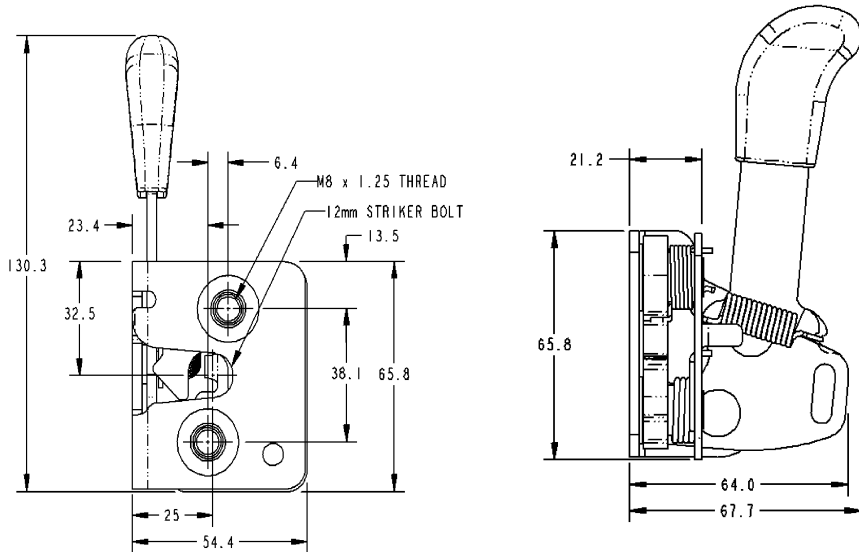

Remote Exterior / Remote Inside Release

The Remote Exterior / Remote Inside Release version features a single actuator that provides remote inside and exterior release for the ultimate in simplicity and application flexibility.

