

REV.	ECN	BY	CHKD	REVISION
4	10359	CML 2/19/98	JJH 2/19/98	REDRAWN ON CAD

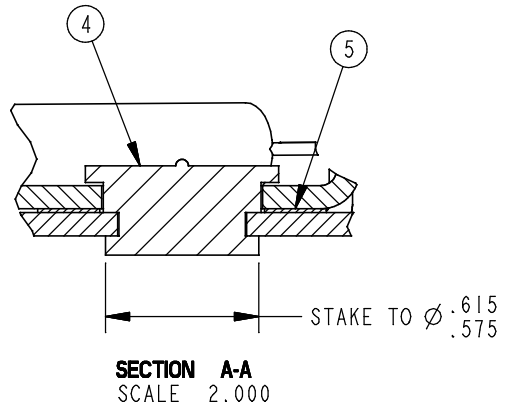
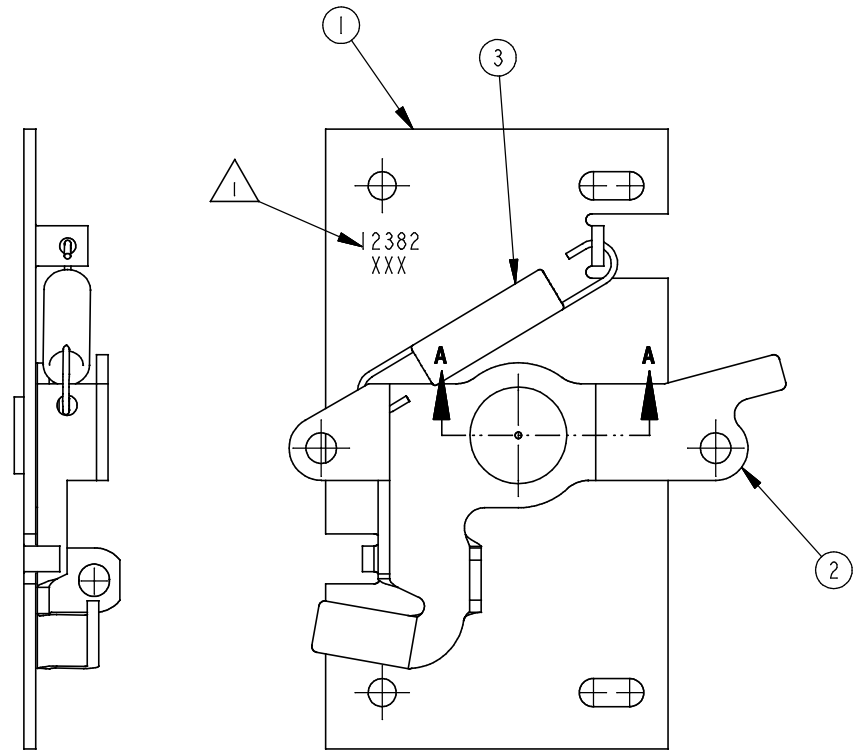

ITEM	PART NO.	DESCRIPTION	QTY.
5	81291-00	WSHR, FL, .640X1.120X.015	1
4	81402-16	RVT, SHLDR, FL, .490X.224X.117	1
3	81287-57	SPR, EXT, EXHK, .049X.360X1.750	1
2	14482-01	PLATE, PIVOT, RH	1
1	81410-16	PLATE, MOUNTING	1

SPEC	DESCRIPTION	ITEM	PART NO.	DESCRIPTION	QTY.
------	-------------	------	----------	-------------	------

<b>DRAWN BY</b>	CRZ	6/22/92	<b>MATL.</b>	
<b>CHECKED BY</b>	DAB	6/25/92	<b>HEAT TREAT</b>	
<b>DESIGN ENG.</b>	DAB	6/25/92	<b>FINISH</b>	
<b>MFG. ENG.</b>			<b>PROJECT</b>	92092
<b>QUALITY ENG.</b>			<b>CUSTOMER</b>	
<b>TOLERANCES UNLESS OTHERWISE SPECIFIED</b>			<b>CUSTOMER PART NO.</b>	
ANSI Y14.5M-1982			<b>SIZE</b>	B
DIMENSIONS			<b>PART WT.</b>	
ANGLES			<b>SURFACE AREA</b>	
X.X	±.1	X°	±3°	<b>PROD CODE</b>
X.XX	±.03	X.X°	±1.0°	090-9999
X.XXX	±.010	X.XX°	±.50°	
INCH [METRIC]			<b>REPORT ERRORS TO ENGINEERING DEPT.</b>	<b>DO NOT SCALE DRAWING</b>
FORM 163-210 REV. 1.0 10/15/93				

**TRI/MARK**  
AN EMPLOYEE-OWNED CORPORATION

Industrial Park  
New Hampton, Iowa 50659  
Telephone: 515-394-3188  
Fax: 515-394-2392

THIS DRAWING AND THE INFORMATION CONTAINED HEREIN IS THE PROPERTY OF TRI/MARK CORP. AND SHALL NOT BE USED FOR ANY PURPOSE WITHOUT OUR WRITTEN CONSENT

**PART NAME**  
ASSY, PLATE, PIVOT, 2 PT

SCALE	REV.	PART NO.
FULL	4	12382-16

NOTES:  
 STAMP MOUNTING PLATE (ITEM 1) WITH DATE CODE AND PART NUMBER PER ES-121. LOCATE APPROXIMATELY AS SHOWN.