



USER MANUAL

## Whisper Power Center

**Unit combining inverter, battery charger  
and transfer system.**



Art.nr. 40200871

WHISPER POWER BV  
Kelvinlaan 82  
9207 JB Drachten  
Netherlands  
Tel.: +31-512-571550  
Fax.: +31-512-571599  
[www.whisperpower.eu](http://www.whisperpower.eu)

V5 July 2012



## TABLE OF CONTENTS

<b>1</b>	<b>INTRODUCTION</b> .....	<b>4</b>
<b>2</b>	<b>GENERAL INFORMATION</b> .....	<b>4</b>
2.1	Operating instructions .....	4
2.2	Conventions .....	4
2.3	Quality and warranty .....	5
2.3.1	Exclusion of warranty .....	5
2.3.2	Exclusion of liability .....	5
2.4	Warnings and notes .....	5
2.4.1	General .....	5
2.4.2	Precautions for using the batteries .....	6
<b>3</b>	<b>ASSEMBLY AND INSTALLATION</b> .....	<b>7</b>
3.1	Handling and moving .....	7
3.2	Storage .....	7
3.3	Unpacking .....	7
3.4	Installation site .....	7
3.5	Fastening .....	7
3.5.1	Fastening .....	8
3.6	Connections .....	8
3.6.1	General recommendations .....	8
3.6.2	Device connection compartment .....	9
3.6.3	Dipswitch functions .....	11
<b>4</b>	<b>CABLING</b> .....	<b>12</b>
4.1	Choice of system .....	12
4.1.1	Hybrid type stand-alone systems .....	12
4.1.2	Grid-connected emergency systems .....	12
4.1.3	Integrated mobile systems .....	12
4.1.4	Multi-unit systems .....	12
4.1.5	Distributed Minigrid: .....	12
4.2	Earthing system .....	13
4.2.1	Mobile installation or installation connected to the grid via plug connector .....	13
4.2.2	Stationary installation .....	13
4.2.3	Installation with automatic PE-neutral switching .....	14
4.2.4	Lightning protection .....	14
4.3	Recommendations for dimensioning the system .....	14
4.3.1	Dimensioning the battery .....	14
4.3.2	Dimensioning the inverter .....	14
4.3.3	Dimensioning the generator .....	15
4.3.4	Dimensioning the renewable energy sources .....	15
4.4	Wiring diagrams .....	15
4.5	Connecting the battery .....	15
4.5.1	Battery cable cross-section and DC protective devices .....	16
4.5.2	Connecting the battery (WPC side) .....	17
4.5.3	Fuse mounting on battery positive pole .....	17
4.5.4	Battery-side connection .....	17
4.5.5	Earthing the battery .....	18
4.5.6	Connecting the consumers at the 230V AC outputs .....	18
4.5.7	Connecting the AC supply sources .....	19
4.5.8	Connecting the communications cables .....	19
4.5.9	Connecting the auto-start cable .....	19
4.5.10	Connecting the temperature sensor (BTS-01) .....	19
<b>5</b>	<b>POWERING UP THE INSTALLATION</b> .....	<b>19</b>
<b>6</b>	<b>DESCRIPTION AND FUNCTIONING</b> .....	<b>20</b>
6.1	Circuit diagram .....	20
6.2	Description of the main functions .....	21
6.2.1	Inverter .....	21
6.2.2	Automatic load detection .....	21



6.2.3	Transfer relay .....	21
6.2.4	Battery charger .....	23
6.2.5	Battery protection.....	25
6.2.6	WPC protection.....	25
<b>7</b>	<b>MULTI-UNIT CONFIGURATION.....</b>	<b>26</b>
7.1.1	Three-phase system.....	26
7.1.2	Increasing the power by paralleling units.....	26
7.1.3	Combined system .....	26
7.1.4	Enlargement of an existing installation.....	26
7.2	Accessories .....	27
7.2.1	Control centre and display WPC-RCC/PSCP (remote control).....	27
7.2.2	BTS-01 temperature sensor.....	28
<b>8</b>	<b>CONTROL .....</b>	<b>29</b>
8.1	Display and control panel .....	29
<b>9</b>	<b>MAINTENANCE OF THE INSTALLATION .....</b>	<b>31</b>
<b>10</b>	<b>PRODUCT RECYCLING.....</b>	<b>32</b>
<b>11</b>	<b>EC DECLARATION OF CONFORMITY.....</b>	<b>33</b>
<b>12</b>	<b>CONTROL AND DISPLAY PARTS FOR THE WPC (FIG. 4B).....</b>	<b>34</b>
<b>13</b>	<b>TABLE OF FACTORY'S (DEFAULTS) PARAMETERS SETTINGS .....</b>	<b>35</b>
<b>14</b>	<b>TECHNICAL DATA – WPC .....</b>	<b>37</b>
<b>14</b>	<b>TECHNICAL DATA – WPC .....</b>	<b>37</b>
14.1	dimensions.....	38
14.2	type plate.....	39
<b>15</b>	<b>NOTES .....</b>	<b>40</b>

# 1 INTRODUCTION

Congratulations! You are about to install and use a device from the Whisper Power Centre range. You have chosen a high-tech device that will play a central role in energy saving for your electrical installation. The WPC has been designed to work as an inverter / charger with advanced functions, which can be used in a completely modular way and guarantee the faultless functioning of your energy system.

When the WPC is connected to a generator or grid, the latter directly supplies the consumers, and the WPC works like a battery charger and backup device if necessary. The powerful battery charger has an exceptional high efficiency and power factor correction (PFC) close to 1. It guarantees excellent battery charging in all situations. The charge profile is freely configurable according to the type of battery used or the method of usage. The charge voltage is corrected depending on the temperature, thanks to the optional external sensor. The power of the charger is modulated in real time dependent according to the demand of the equipment connected at the WPC output and the power of the energy source (grid or generator). It can even temporarily backup the source if the consumer demand exceeds the source capacity.

The WPC continuously monitors the source to which it is connected (grid or generator) and disconnects itself immediately if the source is missing, disturbed or does not correspond to the quality criteria (voltage, frequency, etc.). It will then function in independent mode, thanks to the integrated inverter. This inverter, which has an extremely robust design, benefits from WhisperPower's many years of experience and expertise in this area. It could supply any type of load without faults, enjoying reserves of additional power that is unmatched on the market. All your equipment will be perfectly provided with energy and protected from power outages in systems where energy supply is unpredictable (unreliable grid) or voluntarily limited or interrupted, such as hybrid installations on remote sites or mobile installations.

The parallel and/or three-phase grid operation of the WPC offers modularity and flexibility and enables optimum adaptation of your system to your energy requirements.

The WPC-RCC/PSCP control, display and programming centre enables optimum parametering of the system and guarantees the operator continuous control for all important parameters in the installation.

In order to guarantee perfect commissioning and functioning of your installation, please read this manual carefully. It contains all the necessary information relating to the functioning of the inverters / chargers in the WPC series. The setting up of such a system requires special expertise and may only be carried out by qualified personnel familiar with the applicable local regulations.

## 2 GENERAL INFORMATION

### 2.1 OPERATING INSTRUCTIONS

This manual is an integral part of each inverter/charger from the WPC series.

It covers the following models and accessories:

Inverter/charger: WPC 2000-12, WPC 3500-24, WPC 4000-48

Temperature sensor: WPC-BTS-01

Remote command module: WPC-RCC, WPC-PSCP

For greater clarity, the device is referred to in this manual as WPC, unit or device, when the description of its functioning applies indiscriminately to different WPC models.

These operating instructions serve as a guideline for the safe and efficient usage of the WPC. Anyone who installs or uses a WPC can rely completely on these operating instructions, and is bound to observe all the safety instructions and indications contained. The installation and commissioning of the WPC must be entrusted to a qualified professional. The installation and usage must conform to the local safety instructions and applicable standards in the country concerned.

### 2.2 CONVENTIONS



This symbol is used to indicate the presence of a dangerous voltage that is sufficient to constitute a risk of electric shock.



This symbol is used to indicate a risk of material damage.



This symbol is used to indicate information that is important or which serves to optimise your system.

All values mentioned hereafter, followed by a parameter number indicate that this value may be modified using the WPC remote control.

In general, the default values are not mentioned and are replaced by a parameter number in the following format: {xxxx}. The default values for this parameter are specified in the defaults parameter table, p. 35.



All parameter values modified by the operator or installer must be transferred into the same table. If a parameter not appearing in the list (advanced parameters) has been modified by an authorised person with technical knowledge, they will indicate the number of the modified parameter(s), the specifications of the parameter(s) and the new value set, at the end of the same table.

All figures and letters indicated in brackets or in square brackets refer to items that can be found in the separate manual "Appendix to the installation and operating instructions" supplied with the device. In this appendix, these figures and letters are encircled.

- The **figures** in brackets refer to elements belonging to the **WPC**.
- The **uppercase letters** in brackets refer to **AC** cabling elements.
- The **lowercase letters** in brackets refer to **battery** cabling elements.

## 2.3 QUALITY AND WARRANTY

During the production and assembly of the WPC, each unit undergoes several checks and tests. These are carried out with strict adherence to the established procedures. Each WPC has a serial number allowing complete follow-up on the checks, according to the particular data for each device. For this reason it is very important never to remove the type plate which shows the serial number. The manufacture, assembly and tests for each WPC are carried out in their entirety by our factory in Drachten (the Netherlands). The warranty for this equipment depends upon the strict application of the instructions appearing in this manual. The warranty period for the Whisper Power Centre is 2 years.

### 2.3.1 Exclusion of warranty

No warranty claims will be accepted for damage resulting from handling, usage or processing that does not explicitly appear in this manual. Cases of damage arising from the following causes are notably excluded from the warranty:

- Surge voltage on the battery input (for example, 48 V on the battery input of an WPC 2000-12)
- Incorrect polarity of the battery
- The accidental ingress of liquids into the device or oxidation resulting from condensation
- Damage resulting from falls or mechanical shocks
- Modifications carried out without the explicit authorisation of WhisperPower
- Nuts or screws that have not been tightened sufficiently during the installation or maintenance
- Damage due to atmospheric surge voltage (lightning)
- Damage due to inappropriate transportation or packaging
- Disappearance of original marking elements

### 2.3.2 Exclusion of liability

The placement, commissioning, use, maintenance and servicing of the WPC cannot be the subject of monitoring by WhisperPower. For this reasons we assume no responsibility and liability for damage, costs or losses resulting from an installation that does not conform to the instructions, defective functioning or deficient maintenance. The use of a WhisperPower inverter is the responsibility of the customer in all cases.

This equipment is neither designed nor guaranteed to supply installations used for vital medical care nor any other critical installation carrying significant potential damage risks to people or the environment.

We assume no responsibility for the infringement of patent rights or other rights of third parties that result from using the inverter.

WhisperPower reserves the right to make any modifications to the product without prior notification.

## 2.4 WARNINGS AND NOTES

### 2.4.1 General



This manual is an integral part of the device and must be kept available for the operator and installer. It must remain close to the installation so that it may be consulted at any time.

The parameter table available at the end of the manual (p. 35) must be kept up to date in the event of modification of the parameters by the operator or installer. The person in charge of installation and commissioning must be wholly familiar with the precautionary measures and the local applicable regulations.



When the WPC is running, it generates voltage that can be potentially lethal. Work on or close to the installation must only be carried out by thoroughly trained and qualified personnel. Do not attempt to carry out ongoing maintenance of this product yourself. The WPC or the generator connected to it may start up automatically under certain predetermined conditions.

When working on the electrical installation, it is important to be certain that the source of DC voltage coming from the battery as well as the source of AC voltage coming from a generator or grid have been disconnected from the electrical installation.

Even when the WPC has been disconnected from the supply sources (AC and DC), a dangerous voltage may remain at the outputs. To eliminate this risk you must switch the WPC OFF using the ON/OFF button (1). After 10 seconds the electronics is discharged and intervention may take place without any danger.

All elements connected to the WPC must comply with the applicable laws and regulations.

Persons not holding written authorisation from WhisperPower are not permitted to proceed with any change, modification or repairs that may be required. Only original parts may be used for authorised modifications or replacements.

This manual contains important safety information. Read the safety and working instructions carefully before using the WPC. Adhere to all the warnings given on the device as well as in the manual, by following all the instructions with regard to operation and use.

The WPC is only designed for indoor use and must under no circumstances be subjected to rain, snow or other humid or dusty conditions.

The maximum specifications of the device shown on the type plate, as at fig. 1b, must be adhered to.

In the event of use in motorised vehicles, the WPC must be protected from dust, splash water and any other humid condition. It must also be protected from vibration by installing absorbent parts.

## 2.4.2 Precautions for using the batteries

Lead-acid or gel batteries produce a highly explosive gas with normal use. No source of sparks or fire should be present in the immediate vicinity of the batteries. The batteries must be kept in a well-ventilated place and be installed in such a way as to avoid accidental short-circuits when connecting.

Never try to charge frozen batteries.

When working with the batteries, a second person must be present in order to lend assistance in the event of problems.

Sufficient fresh water and soap must be kept to hand to allow adequate and immediate washing of the skin or eyes affected by accidental contact with the acid.

In the event of accidental contact of the eyes with acid, they must be washed carefully with cold water for 15 minutes. Then immediately consult a doctor.

Battery acid can be neutralised with baking soda. A sufficient quantity of baking soda must be available for this purpose.

Particular care is required when working close to the batteries with metal tools. Tools such as screwdrivers, open-ended spanners, etc. may cause short-circuits. Consequently occurring sparks may cause the battery to explode.

When working with the batteries, all metal jewellery such as rings, bracelet watches, earrings, etc., must be taken off. The current output by the batteries during a short-circuit is sufficiently powerful to melt the metal and cause severe burns.

In all cases, the instructions of the battery manufacturer must be followed carefully.

## 3 ASSEMBLY AND INSTALLATION

### 3.1 HANDLING AND MOVING

The weight of the WPC is between 35 and 50kg depending upon the model. Use an appropriate lifting method as well as help from a third party when installing the equipment.

### 3.2 STORAGE

The equipment must be stored in a dry environment at an ambient temperature of between -20°C and 60°C. It stays in the location where it is to be used a minimum of 24 hours before being set up.

### 3.3 UNPACKING

When unpacking, check that the equipment has not been damaged during transportation and that all accessories listed below are present. Any fault must be indicated immediately to the product distributor or the contact given at the back of this manual.

Check the packaging and the WPC carefully.

Standard accessories:

- Installation and operating instructions, c.f. Appendix 1
- Mounting plate – fig. 2a (18)
- Cable gland

### 3.4 INSTALLATION SITE

The installation site for the WPC is of particular importance and must satisfy the following criteria:

- Protected from any unauthorised person.
- Protected from water and dust and in a place with no condensation.
- It must not be situated directly above the battery or in a cabinet with it.
- No easily inflammable material should be placed directly underneath or close to the WPC.
- Ventilation apertures must always remain clear and be at least 20cm from any obstacle that may affect the ventilation of the equipment.
- In mobile applications it is important to select an installation site that ensures as low a vibration level as possible.

### 3.5 FASTENING



The WPC is a heavy unit and must be mounted to a wall designed to bear such a load. A simple wooden panel is insufficient.

The WPC must be installed vertically with sufficient space around it to guarantee adequate ventilation of the device.

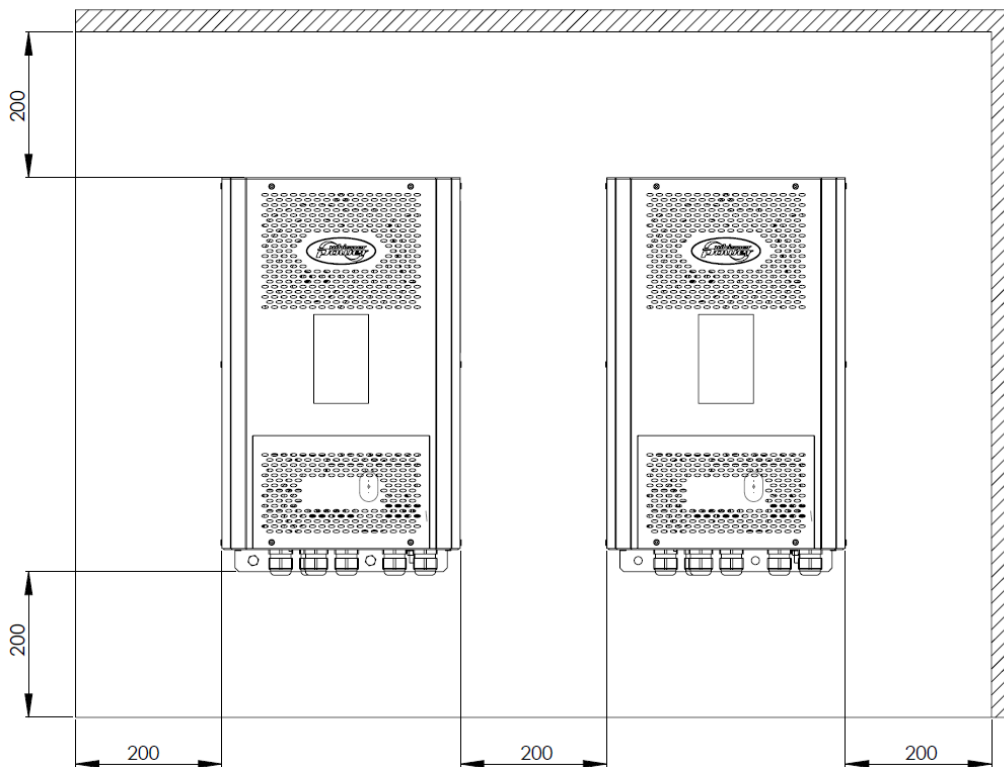

### 3.5.1 Fastening

Screw on a solid wall (concrete or metallic wall) the supplied mounting washer using a suitable bolt.

Hang the WPC unit on the wall using the upper bracket on the backside of the WPC. Make sure that the bracket is securely fixed. For mobile and marine applications it is also necessary to fix the unit using the bottom mount. Use two bolts to secure the bottom mount to the wall.



It is imperative to ensure complete and safe fastening of the device. A device that is simply hung may detach and cause severe damage.

In motor vehicles or when the support may be subject to strong vibrations, the WPC must be mounted on anti-vibration supports.

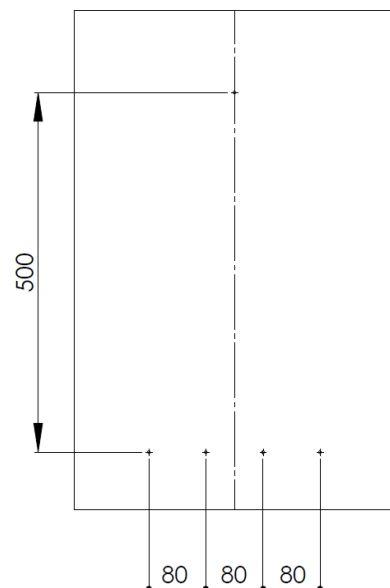

## 3.6 CONNECTIONS

### 3.6.1 General recommendations

The WPC falls within protection class I (has a PE connection terminal). It is vital that a protective earth is connected to the AC IN and/or AC OUT PE terminals. An additional protective earth is located between the two fastening screws at the bottom of the unit (17).



In all cases, the PE conductor for the equipment must at least be connected to the PE for all equipment in protection class I upstream and downstream of the WPC (equipotential bonding). It is mandatory that the legislation in force for the application concerned be adhered to.



Tighten of the input (13) and output (14) terminals by means of a no. 3 screwdriver.

The cable sections of these terminals must conform to local regulations.

All connection cables as well as the battery cables must be mounted using cable restraints in order to avoid any traction on the connection.

Battery cables must also be as short as possible and the section must conform with the applicable regulations and standards. Sufficiently tighten the clamps on the “battery” inputs (11) and (12).

### 3.6.2 Device connection compartment



The unit's connection compartment must remain permanently closed when in operation. It is imperative to close the protection cap on the connection terminals after each intervention in the device.

After opening, check that all sources of AC and DC voltage (batteries) have been disconnected or put out of service.

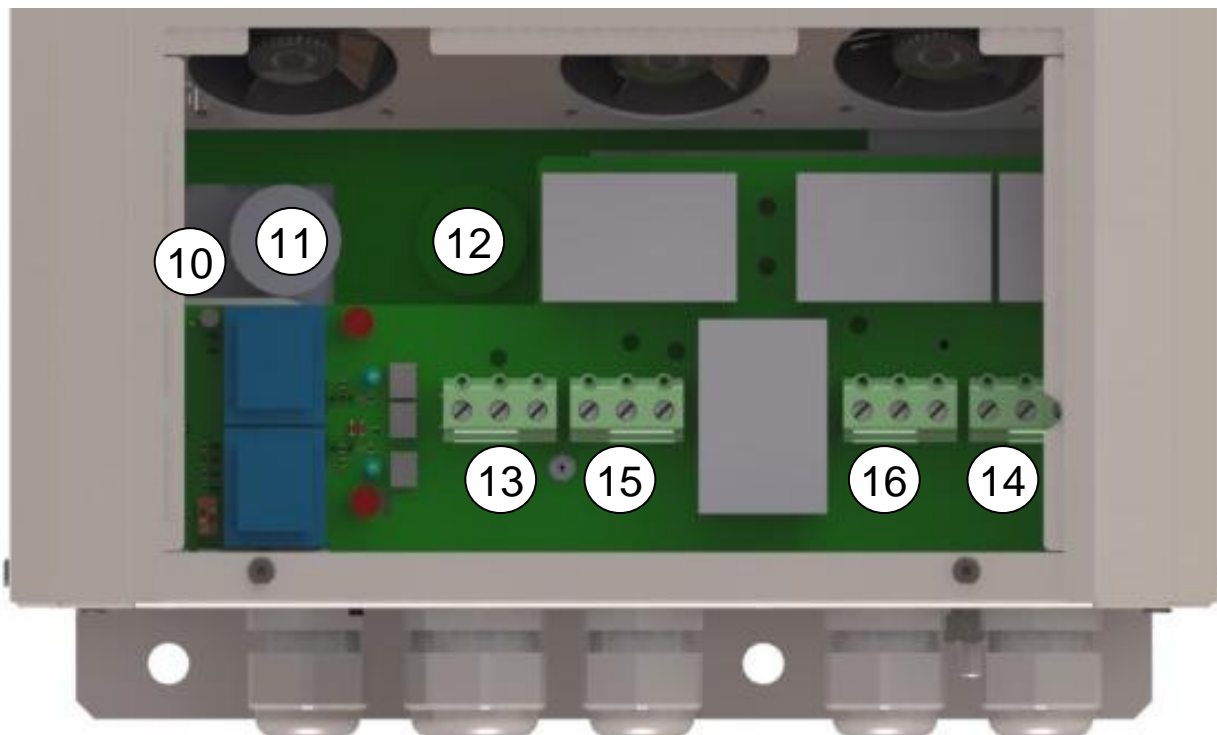

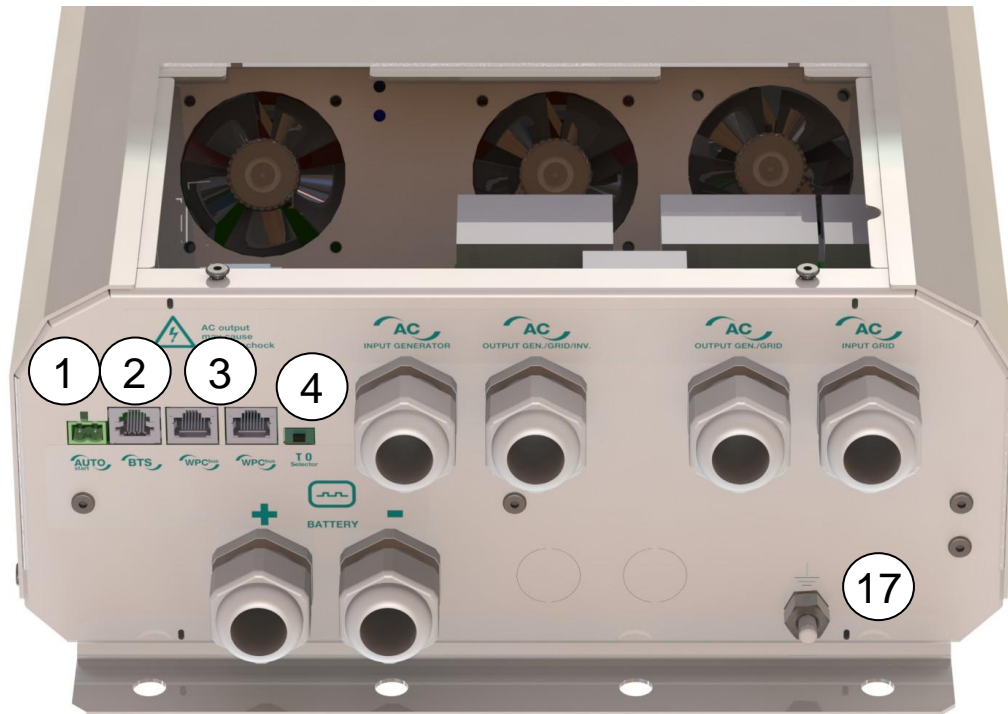

Pos.	Denomination	Description	Comment
1	Auto start	Connector for connecting the auto-start cable	Refer to DDC and RCC/PSCP manual
2	Temp. Sens	Connector for the battery temperature sensor	See chapter 8.2.2 – p. 28. Only connect the original WhisperPower BTS-01 sensor
3	WPC bus	Double connector for connecting peripherals such as the RCC/PSCP or other WPC units	See chapter 4.5.8 – p. 19. The two termination switches (4) for the communication bus both remain in position T (terminated) except when both connectors are in use.
4	O / T (Open / Terminated)	Switch for terminating the communication bus.	
10	L1/L2/L3	Phase selection jumpers.	Jumper default at position L1
11	+BAT	Positive pole battery connection terminals	Carefully read chapter 4.5 – p.15 Take care with the polarity of the battery and when tightening the clamp.
12	-BAT	Negative pole battery connection terminals	
13	AC Input Generator	Connection terminals for the AC generator	See chapter 4.5.7 - p. 19. Note: It is imperative that the PE terminal be connected.
14	AC Input Grid	Connection terminals for the AC grid	See chapter 4.5.7 - p. 19. Note: It is imperative that the PE terminal be connected.
15	AC Output Gen/Grid/Inv	Connection terminals for the device output. (Continuous)	See chapter 4.5.6 - p. 19. Note: Increased voltages may appear on the terminals, even in the absence of voltage at the input of the inverter.
16	AC Output Gen/Grid	Connection terminals for the device output.(Only active when AC input is present)	See chapter 4.5.6 - p. 19. Note: Increased voltages may appear on the terminals, even in the absence of voltage at the input of the inverter.
17		Protective earth	See chapter 3.6.1 – p. 8 and 4.2 p. 13

### 3.6.3 Dipswitch functions

To set the behavior of the input switching component of the WPC a dipswitch is available at the input switching board. To access it, open the connection compartment cover. The figure below show the location of the dipswitch.

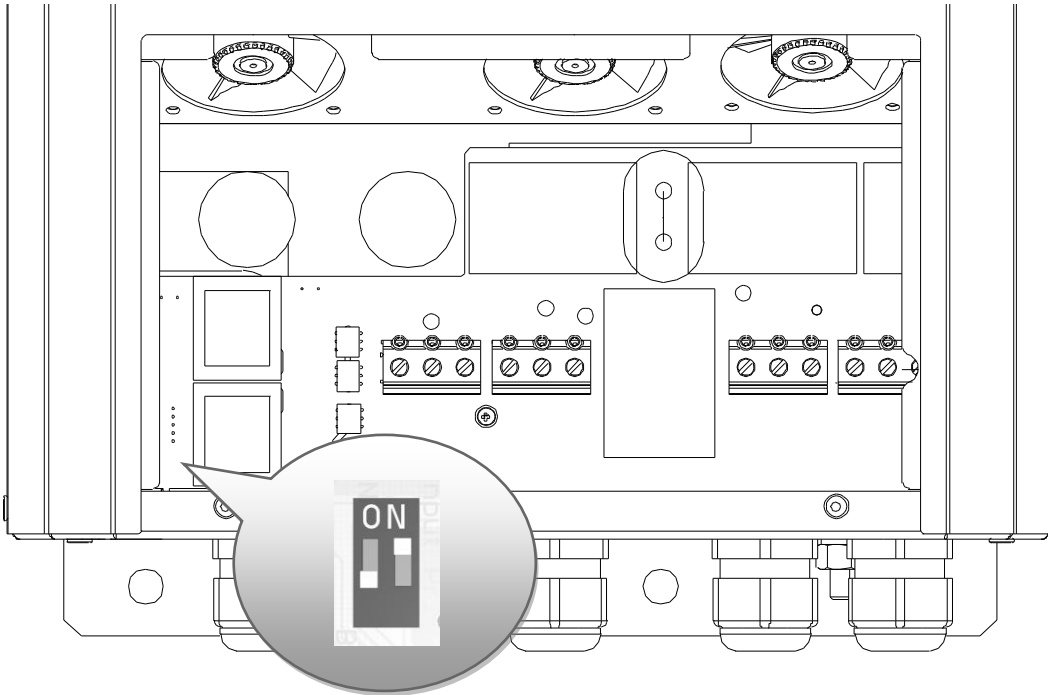

*Dipswitch location*

Dipswitch	Function	Default
1	Prohibit automatic start when grid is available	Off
2	Preferred input ON = Generator Off = Grid	On

#### 3.6.3.1 Prohibit automatic start when grid is available

Default the generator will automatically start when one of auto start criteria is met. It starts even when the is AC grid is connected. In some cases the AC grid can supply more power than the generator. In this situation it is most likely that starting of the generator is not wanted. To prohibit the generator from starting in this situation set the upper dipswitch to the “ON” position. Now the Autostart signal will indicate “start” only when there is no grid available. Refer to the figure above for the position of the dipswitch.

#### 3.6.3.2 Preferred input

When both AC inputs are available, this setting will determine which AC input is passed through for power delivery.

## 4 CABLING

The connection of the WPC inverter / charger is an important installation step.

It may only be carried out by qualified personnel and in accordance with the applicable local regulations and standards. The installation must always comply with these standards.

Pay attention that connections are completely tightened and that each wire is connected at the right place.

### 4.1 CHOICE OF SYSTEM

The WPC may be used in different system types, each of which must meet the standards and particular requirements associated with the application or site of installation. Only an appropriately qualified installer can advise you effectively on the applicable standards with regard to the various systems and the country concerned.

#### 4.1.1 Hybrid type stand-alone systems

The WPC can be used as a primary supply system for off-grid sites where a renewable energy source (solar or hydraulic) is generally available and a generator is used as backup. In this case, batteries are generally recharged by a supply source such as solar modules, wind power or small hydropower systems. These supply sources must have their own voltage and/or current regulation system and are connected directly to the battery.

When the energy supply is insufficient, a generator is used as a back-up energy source. This allows the batteries to be recharged and direct supply to consumers via the WPC transfer relay.

#### 4.1.2 Grid-connected emergency systems

The WPC can be used as an emergency system, also known as an uninterruptible power supply (UPS) – enabling a reliable supply to a site connected to an unreliable grid. In the event of an interruption to the energy supply from the public grid, the WPC, connected to a battery, substitutes the faulty source and enables a support supply to the users connected downstream. These will be supplied as long as the energy stored in the battery allows. The battery will quickly be recharged at the next reconnection to the public grid.



The use of the WPC as a UPS must be carried out by qualified personnel who have been checked by the responsible local authorities. The diagrams in the appendix are given for information and as a supplement. The applicable local standards and regulations must be adhered to.

#### 4.1.3 Integrated mobile systems

These systems are meant to be temporarily connected to the grid and ensure the supply of the mobile system when this is disconnected from the grid. The main applications are for boats, service vehicles and leisure vehicles. For these purposes the WPC has a double AC input.

#### 4.1.4 Multi-unit systems

Whatever system is selected, it is possible to realise systems composed of several units of the same type and the same power output. Up to three WPC's in parallel or three WPC's forming a three-phase grid or three times two or three WPC's in parallel forming a three-phase / parallel grid, may be thus combined.

#### 4.1.5 Distributed Minigrid:

The implementation of the WPC on top of a distributed minigrid (beyond the main building) requires special care in choosing the distribution system.

WhisperPower recommends a TT distribution for the DC grid as well as for the AC grid.



The size of the grid increases greatly the exposure of the inverters to atmospheric overvoltages and to non equipotentiality in the grid. This is particularly noticeable in the aerial distribution grids. In this case a very special care must be taken to well implementing all protection measures of the installation.



The IT system is not recommended for the distribution. This kind of distribution is most of the time forbidden by the local laws. The achievement of low voltage electric system is always subject to local laws and must imperatively be implemented and controlled by qualified and professionally authorized staff. WhisperPower accepts no liability for damages due to non confirming installation and to the lack of compliance with the local rules or with the recommendations of this manual.

## 4.2 EARTHING SYSTEM

The WPC is a protection class I unit, which is intended for cabling in a grid type TT, TN-S or TNC-S. The earthing of the neutral conductor (E) is carried out at a sole installation point, upstream of the RCD circuit breaker (D).

The WPC can be operated with any earthing system. In all cases it is imperative that the protective earth be connected in compliance with the applicable standards and regulations. The information, notes, recommendations and diagram mentioned in this manual are subject to local installation regulations in every case. The installer is responsible for the conformity of the installation with the applicable local standards.

### 4.2.1 Mobile installation or installation connected to the grid via plug connector

When the input of the device is connected directly to the grid via a plug, the length of the cable must not exceed 2 m and the plug must remain accessible.

In the absence of voltage at the input, the neutral and live are interrupted, thereby guaranteeing complete isolation and protection of the cabling upstream of the WPC.

The earthing system downstream of the WPC is determined by the upstream earthing system when the grid is present. In the absence of the grid, the earthing system downstream of the inverter is in isolated mode. The safety of the installation is guaranteed by the equipotential bonding.



The connection (link) between the neutrals (C) upstream and downstream of the WPC is not permitted in this configuration.

This connection type guarantees the optimal continuity for supplying the WPC loads. The first isolation fault will not lead to an interruption in the supply.

If the installation requires the use of a permanent isolation controller this would have to be de-activated when the TT grid is present at the WPC input.



All sockets and protection class I devices connected downstream of the WPC must be properly connected to the earth (earthed socket). The cabling rules above remain valid, including in installations, in all cases where the WPC input is connected to the grid via a plug connector.

### 4.2.2 Stationary installation

The installation may be equivalent to a mobile installation (with interrupted neutral).

In a fixed installation where the neutral is connected to the earth at a single installation point upstream of the WPC, it is permissible to carry out a connection of the neutrals in order to preserve an unchanged earthing system downstream, independent of the operating mode of the WPC. This choice has the advantage of keeping the protection devices downstream of the WPC. This connection can be executed according to the next figure, or carried out by modifying the parameter {1486}

In this case the appearance of the first fault will lead to the installation stopping or the disconnection of the protection devices upstream and/or downstream of the WPC.

Safety is guaranteed by the equipotential bonding and by any RCD circuit-breakers placed downstream.

This connection (C) is not permitted if a socket is installed upstream of the WPC.

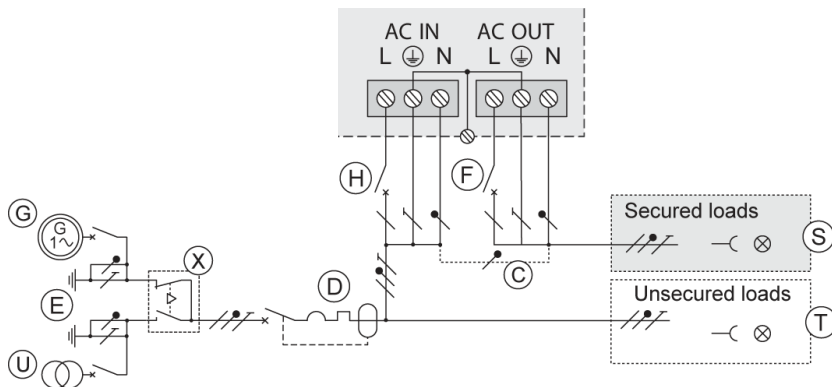

### 4.2.3 Installation with automatic PE-neutral switching

In certain applications, it is desirable to keep the neutral upstream and downstream of the WPC separated (C) while re-establishing the earthing system (TN-S, TT or TNC-S) in the absence of voltage at the input. This functionality is forbidden by default by the parameter {1485}. This parameter can be modified by the parameter {1485} via the WPC-RCC/PSCP remote control. This modification must be carried out possessing technical knowledge, at the responsibility of the installer and in conformity with the applicable regulations and standards.

The authorization of this function adherence to the requirements for an earth-neutral connection at the source.

### 4.2.4 Lightning protection

As per the installation site, it is highly recommended to set a protection strategy to protect your installation against lightning. The strategies depend on various parameters directly linked to each site and we recommend therefore to deal very professionally with this issue.



The damages due to lightning are generating most of the time significant costs (full replacing of the printed electronic board) and are not covered by WhisperPower's warranty.

## 4.3 RECOMMENDATIONS FOR DIMENSIONING THE SYSTEM

### 4.3.1 Dimensioning the battery

The battery capacity is dimensioned according to the requirements of the user – that is 5 to 10 times its average daily consumption. The discharge depth of the battery will therefore be limited and the service life of the battery will be extended.

On the other hand, the WPC must have a battery capacity that is large enough to be able to take full advantage of the performance of the equipment. The minimum capacity of the batteries (expressed in Ah) is generally dimensioned in the following way: five times the rated power output of the WPC / the battery voltage. For example, the model 3500W/24V must have a battery of a minimum capacity of  $3500 \times 5 / 24 = 730$  Ah (C 10). Because of the inverter's extreme overload capacity, it is often recommended that this value be rounded up. An under-dimensioned battery may lead to an accidental and undesired stopping of the WPC in the event of high instances of use. This stoppage will be due to a voltage that is insufficient on the battery, subject to a strong discharge current.

The battery will be selected with regard to the greatest value resulting from the calculations set out above.

The battery capacity determines the adjustment of the parameter {1137} "battery charge current". A value between 0.1 and 0.2 x C batt. [Ah] (C10) enables an optimum charge to be guaranteed.



The method proposed below is strictly indicative and in no way constitutes a guarantee of perfect dimensioning. The installer is solely responsible for good dimensioning and installation

### 4.3.2 Dimensioning the inverter

The inverter is dimensioned in such a way that the rated power output covers the power of all the consumers

which will be used at the same time. A dimensioning margin of 20 to 30% is recommended to guarantee that the WPC will work well in an ambient temperature of more than 25 °C.

### 4.3.3 Dimensioning the generator

The power output of the generator must be the same or more than the average daily power. Optimally, it should be once or twice times this power. Thanks to the Smart Boost function (see chap.1.1.1 p.25) it is not necessary to over-dimension the generator. Indeed, the loads those are temporarily higher than the power of the generator will be supplied by the inverter. Ideally it should not have a power output by phase that is less than half of the power of the WPC(s) present at this phase.



The power available downstream of the inverter when the generator is working is the same as the sum of the two powers if the Smart Boost function is activated. The sum of the currents is limited to a maximum of 30A

### 4.3.4 Dimensioning the renewable energy sources

In a hybrid system, the alternative energy sources such as the solar generator, wind power and small hydropower should, in principle, be dimensioned in such a way as to be able to cover the average daily consumption.

## 4.4 WIRING DIAGRAMS



The diagrams shown in this document are subsidiary. The applicable local installation regulations and standards must be adhered to.  
The elements referred to with an uppercase letter denote the alternate current (AC) part.  
The elements referred to with a lowercase letter denote the direct current (DC) part.

## 4.5 CONNECTING THE BATTERY

Lead batteries are usually available in 2 V, 6 V or 12 V block types. In the majority of cases, in order to obtain an operating voltage that is correct for WPC usage, several batteries must be connected in series or in parallel depending on the circumstances.

12V battery bank wiring with 2Vcell in series and parallel+series

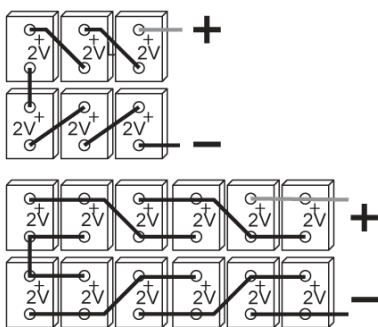

12V battery bank wiring with single and parallel 12Vcell

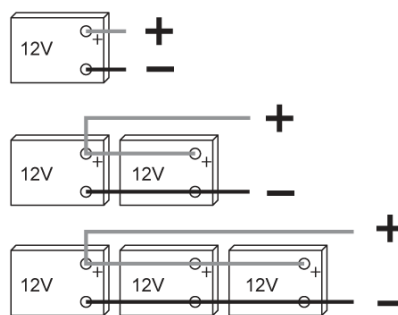

24V battery bank wiring with 2Vcell in serie and parallel+series

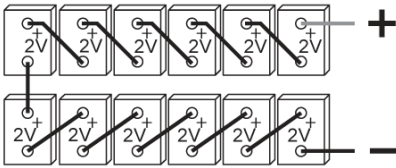

24V battery bank wiring with series and series/parallel 12Vcell

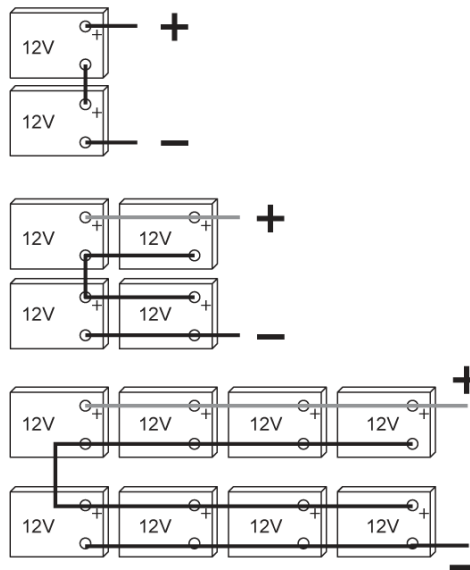

48V battery bank wiring with series/parallel 12Vcells

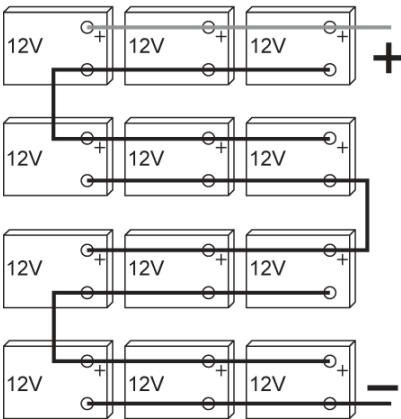

48V battery bank wiring with series 12Vcells

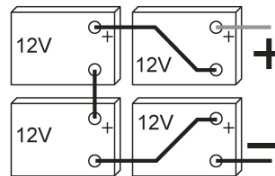

48V battery bank wiring with 2Vcell in series

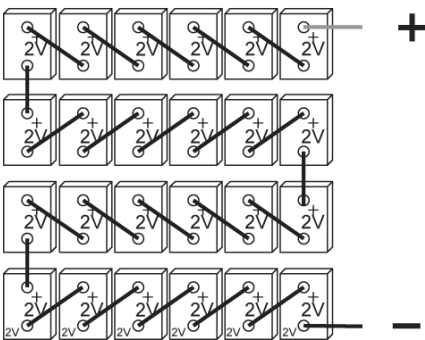

48V battery bank wiring with 2Vcell in parallel+series

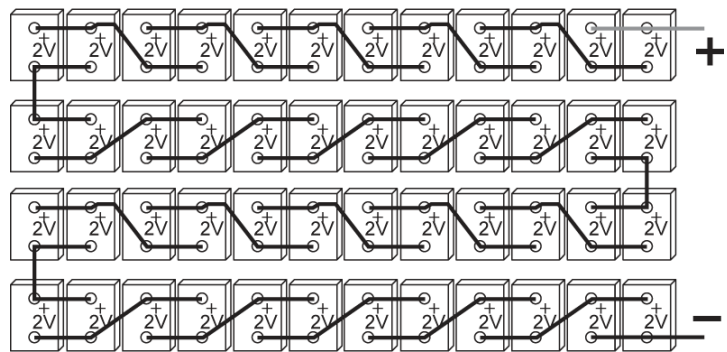

### 4.5.1 Battery cable cross-section and DC protective devices





The battery cables must be protected by one of the following measures in all cases:

- protection device (fuse) at each pole
- protection device (fuse) on the pole not connected to the earth

The battery cables must also be as short as possible.

It is always preferable to keep the cable at the negative pole of the battery as short as possible.

In order to avoid any further loss and protection redundancy. A protective device (f) must be installed as close as possible to the battery and sized according to the below table.

Range	Battery side fuse	Section of cable (<3m)
WPC-4000-48	200A	50mm <sup>2</sup>
WPC-3500-24	300A	70mm <sup>2</sup>
WPC-2000-12	300A	70mm <sup>2</sup>

The recommended cable cross-sections are valid for lengths less than 3 m. beyond this length it is strongly recommended to oversize the battery cables.

For safety reasons, we recommend an annual check on the tightness of all connections.

For mobile installation the connections should be checked more frequently for tightness.

The cable lugs must be carefully fixed and tightened sufficiently to guarantee minimum loss. Insufficient tightening may cause dangerous heating at the connection point.

### 4.5.2 Connecting the battery (WPC side)

Insert the cable glands supplied on the battery cable before tightening the cable lugs. Crimp the cable lugs and fasten the cable gland on the device. Repeat this for the second battery cable. Fix the battery cables to the appropriate connections „+ Battery “and „- Battery “. The M8 screws must be very well tightened.

You can insert, if required, a fuse directly on the positive connection to the battery following the below procedure.



If cable glands are omitted or if there is no cable inserted in the cable gland, there is a high risk of penetrating of small animals inside the unit and a risk of damage not covered by warranty. Any unused cable gland on the unit must be properly closed.

### 4.5.3 Fuse mounting on battery positive pole

A fuse delivered with the unit (WPC) can be mounted directly on the positive connecting pole to the battery respecting the below stacking order.

The presence of this fuse does not exempt an installation of a protective device (fuse or circuit breaker) as close as possible of the battery.

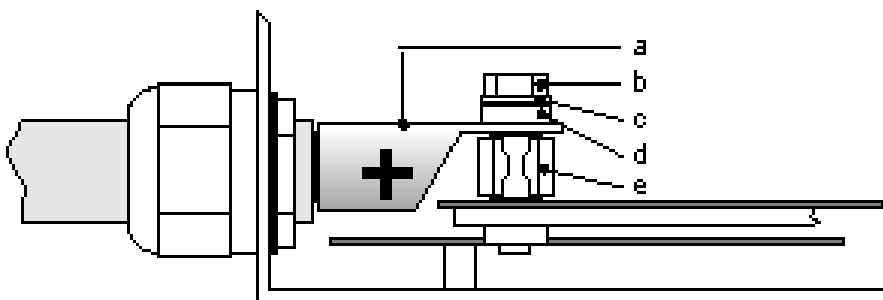

- a = M10 cable lug
- b = bolt M10 x 30
- c = washer
- d = ceramic washer
- e = fuse



Be careful with the orientation of the ceramic washer. There is a small lip on one side which must fit into the M10 cable lug's hole.

### 4.5.4 Battery-side connection



Before connecting the battery, carefully check the voltage and polarity of the battery using a voltmeter.

Incorrect polarity or over-voltage may seriously damage the device.

Prepare the batteries for connection: appropriate battery clamps, protection device (f), cable in good conditions with correctly fitted clamps.

Fasten the negative cable on to the negative pole (-) of the battery and the positive cable on the open protection device (f).



When connecting the battery, a spark may occur when connecting the second pole. This spark is normal and due to the charging of the internal filtering capacitor of the WPC even if the unit is halted by the main On/Off command (1).



As of the connection of the battery, it is necessary to check that the parameter values of the WPC are consistent with the recommendations of the battery manufacturer. Non-conforming values may be dangerous and/or seriously damage the batteries.

The default values of the battery's charge threshold level are shown in fig. 3a and specified in the parameter table p.35. If they are not acceptable when compared to the battery's manufacturer's specification, it is necessary to modify them via the remote control before connecting the voltage sources on the AC input (charger). WhisperPower is not responsible for default values not corresponding with the recommendations of the manufacturer.

**If the factory settings are modified, the new values must be entered on the parameter table on p. 35 of this manual.** The default values proposed by WhisperPower are the usual values for lead acid battery or gel batteries (VRLA or AGM).

The cabling and connection of the installation should only be carried out by an appropriately qualified professional. The installation material such as cables, connectors, distribution boxes, fuses, etc. must be adapted and must conform to the applicable laws and regulations the application under consideration.

#### 4.5.5 Earthing the battery

One of the two battery conductors can be earthed. This may be either the positive or negative pole. In all cases the installation must conform to the local regulations and usage or specific standards associated with the application.

In case of earthing, the earthing conductor section must at least be equivalent to the section of the battery conductor. The earthing of the equipment must also adhere to these regulations. In this case the use of the additional earthing screw is recommended (17), which is located at the front of the device between the two lower fastening screws.

#### 4.5.6 Connecting the consumers at the 230V AC outputs



High voltages may be present on the connection terminals (13) and (14). Make sure that the inverter is deactivated and that there is no AC or DC voltage present on the AC IN terminals and battery terminals, before proceeding with the connection.

The 230V consumers must be connected to the "AC OUT" (15) and (16) connection terminals with the wire section conforming to the standards with regard to the rated current at the WPC output. Distribution must conform to the local standards and regulations, and generally, be realised via a distribution table.

The WPC terminals are marked in the following way:

N = neutral, L = live

PE = protective earth (connected to the enclosure of the device).



Due to the source assistance function (Smart Boost) the current at the output of the device may be higher than the rated current of the inverter. It is the sum of the current supplied by the additional source and the current supplied by the inverter. In this case, the dimensioning of the output cables will be carried out by adding the current indicated on the protection device (H) located on the upstream of the unit, to the nominal current of the inverter. (See also chap. 1.1.1 – p. 25)

If the assistance function at the source (Smart Boost) is not used, the size of the protection device for the output (F) will be established at a maximum value equal to the rated current of the inverter, or at the maximum value of the protection device at the input (H) if this exceeds the rated current of the inverter.



An additional earthing terminal (17) is present between the two fastening screws at the bottom of the unit. It can be used instead of a connection on the input terminals of the device, particularly when cable cross-sections used at the output do not allow the use of a three-wire cable (live, earth and neutral) through the conduit glands of the connection cables of the input and output (AC IN and AC OUT), or when the earthing of one of the poles of the battery. PE required using same or greater cross-sections than the battery cable.

#### 4.5.7 Connecting the AC supply sources

The WPC is intended to be supplied by alternative voltage sources such as the public grid and/or a generator. Check that the rated voltage of the source corresponds to the rated voltage (34) of the WPC specified on the type plate (fig. 1b).

The source must be connected to the input terminals marked "AC INPUT" (13) with sufficient wire section, depending on the power output of the source, and protected by a protection device of the appropriate calibre. This will be at the maximum equal to the current  $I_{AC}$  in max (35) specified on the type plate. The terminals are marked in the following way:

N = neutral, L = live, PE = protective earth (connected to the enclosure of the device).



**Any unused cable gland on the unit must be properly closed.**

If not, there is a high risk of intrusion of small animals inside the unit and a risk of damage not covered by warranty

#### 4.5.8 Connecting the communications cables

The WPC is equipped with a pair of RJ45/8 connectors that allow information transfer via a communication bus for different consumer types which have the proprietary protocol of WhisperPower. In this network all parties in the network are connected in series (chain).

The length of the communication bus cable must not exceed 300 m.

In a system comprising a single WPC, the connection of the WPC remote control may be conducted without stopping the WPC (hot plug).

The communication bus will be used to interconnect other WPC inverters in the case of a multi-unit application or to connect other types of users who have the proprietary protocol of WhisperPower. In these cases, the installation must be switched off using the main "ON/OFF" button (41) p. 29 to connect the units via the communication bus.



The 2 switches for the communication bus termination, "WPC Bus" (4) both remain in position T (terminated) except when both connectors are in use. In this case, and only in this case, both must be placed in the O open position. If one of the two connectors is not in use, the two termination switches (14) will be in position T.

#### 4.5.9 Connecting the auto-start cable

The WPC is able to start the generator automatically when needed. To use this function the auto-start cable has to be connected between the WPC (1) and the RCC/PSCP. (refer to RCC/PSCP manual)

#### 4.5.10 Connecting the temperature sensor (BTS-01)

The temperature sensor, BTS-01 is supplied with a 3 m cable fitted with RJ11/6-type plugs. It may be connected or disconnected at any time (including when the device is in use) using the corresponding socket (2) marked "TS" on the WPC. Plug the connectors into the socket (2) until they click in. The temperature sensor sleeve may simply be stuck onto the battery or directly next to it. The temperature sensor will be recognised automatically and the correction made immediately.

## 5 POWERING UP THE INSTALLATION



It is imperative that the closing cap for the connection compartment be installed and screwed tight before the installation is energised. There are dangerous voltages within the interior of the connection compartment.

The Power up of the WPC must be carried out in the order given below. Any Power off must be carried out in the reverse order.

	<p>A too high or inappropriate battery voltage may seriously damage the WPC. For example, connecting a 24 V battery to the WPC 2000-12.</p> <p>If the WPC has been connected the wrong way around by accident (incorrect polarity of the battery) it is highly likely that the protection fuse on the battery cable may melt and will have to be replaced. If such is the case, it will be necessary to disconnect all the connections to the WPC including the battery. If, after replacing the fuse, the WPC proves not to work correctly after reconnecting the battery with the correct polarity, it will have to be returned to your distributor for repair.</p>
---	---

- Connecting the battery
- The WPC is supplied and is ready for operation.
- Connecting the consumers at the outputs.

Activate the output protection device (F) if existing, and/or press the ON/OFF button (41). The light indicator "AC out" (46) lights up or flashes (in the event of an absence of consumers).

- Activating the input circuit breaker(s) (H)

If an AC source (generator or electrical grid) valid in frequency and voltage is present at the AC input, the device automatically goes into transfer and will start to charge the batteries. The consumers at the output are therefore supplied directly by the power source present at the input.

Your installation is now in operation. If particular parameter or adjustment is required by the system, it is recommended to carry this out immediately. Adjustments must be made with the WPC-RCC/PSCP remote control. Please refer to the operating instructions for this accessory.

## 6 DESCRIPTION AND FUNCTIONING

### 6.1 CIRCUIT DIAGRAM

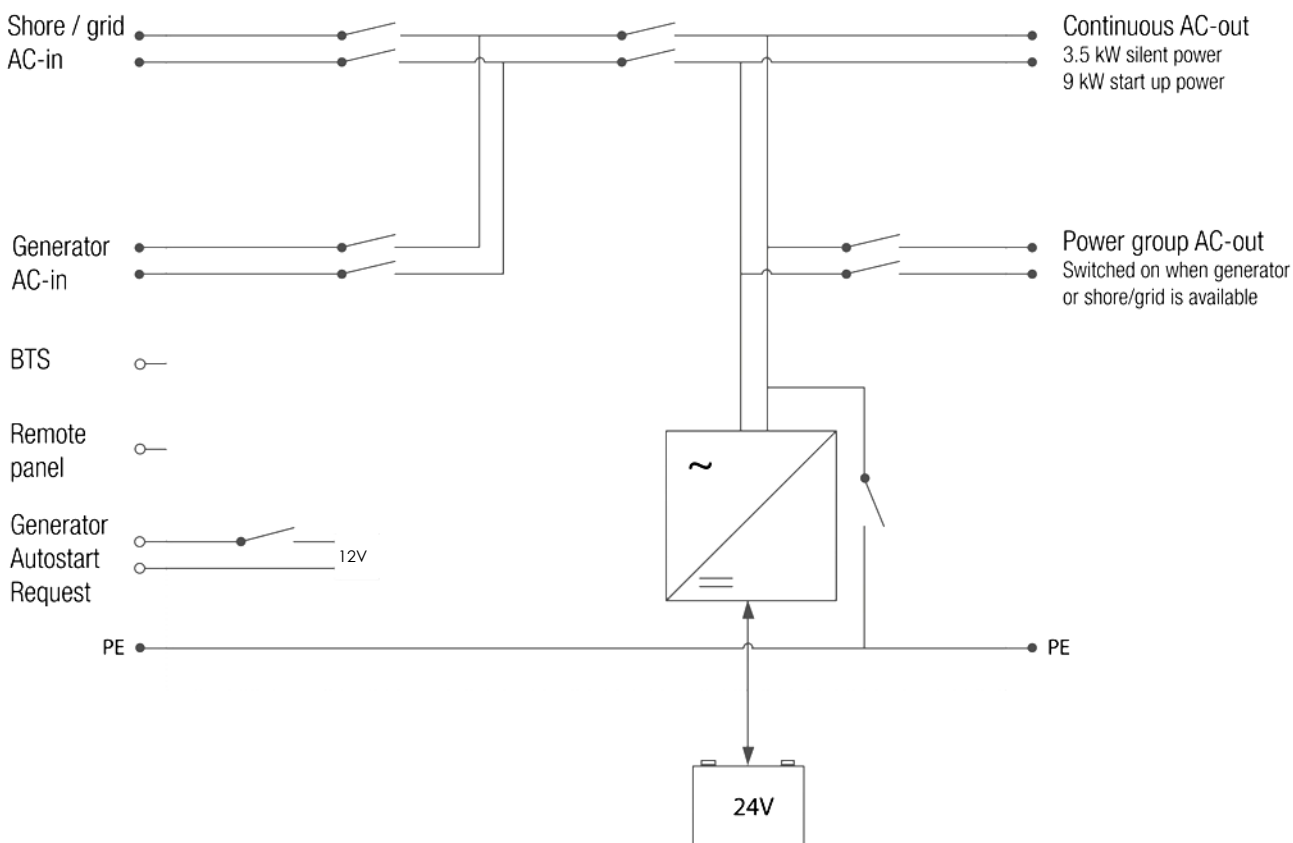

## 6.2 DESCRIPTION OF THE MAIN FUNCTIONS

### 6.2.1 Inverter

The WPC is equipped with a high-performance inverter which supplies a perfect and very precise sine wave. Any unit designed for the 230 V/50 Hz electrical grid may connect to it without any problem, up to the rated power out of your WPC. The inverter is protected against overloads and short-circuits.

Thanks to the largely over-dimensioned performance level, loads of up to three times greater than the WPC's rated output can be faultlessly supplied for short periods of use, thus allowing motors to be started up without any problem.

When the WPC is operating the LED "ON" (43) is glowing.

When the WPC is in inverter mode, the LED "AC out" (46) is glowing. If it flashes, the inverter is in "load search" mode (see following chapter "Automatic load detection").

### 6.2.2 Automatic load detection

In order to save battery energy, the WPC inverter stops and automatically goes into load search when the detected load is lower than the sensitivity set by the parameter {1187}. It automatically goes back into operation when a power consumer greater than this value demands it. The indicator (46) flashes if the inverter is in "load search" mode, which also indicates that the AC voltage is present at the output in an intermittent form.

The detection threshold for the absence of loads can be adjusted according to the parameter range {1187} by means of the WPC-PSCP / RCC remote control. When the parameter is set to 0 the inverter will still operate even in the absence of any consumer.

In standby mode the system will thus consume minimal power from the battery (see table of technical data p. 36).

### 6.2.3 Transfer relay

The WPC can be connected to an alternative power source such as a generator or public grid. When the voltage at the entry satisfies the voltage {1199 + 1470} and frequency {1505 - 1506} parameters, the transfer relay will be activated after a delay {1528}. This delay may be adjusted(extended) to allow a fully stable status of the generator before transfer.

When the transfer relay is activated, the voltage present at the input of the WPC is available at the output for the consumers connected. At the same time the battery charger goes into operation.



When the transfer relay of the WPC is active, the voltage at the output of the WPC is equivalent to that which is present at the input and cannot be influenced or improved by the WPC. The consumers are supplied by the source present at the "AC IN" input via the transfer relay.

The maximum current of the transfer relay is 30 A. This means that the permanent power of the consumers must be a maximum of 11,500 W at 230 V (see chap. 1.1.1 p. 25). If the battery charger is in operation, part of this power will be used for the battery charge.

The sharing of energy between consumers and the battery charger is adjusted automatically (see chap. 1.1.1 – p. 25). The transfer relay will be deactivated when the input voltage no longer satisfies the parameter {1199} or {1432} min. and max. voltage and frequency at the input or when the current limit {1107} is exceeded, if the exceeding of this limit is prohibited {1436} It then passes immediately into inverter mode. In this case the loads are supplied exclusively by the battery via the inverter (see chap. 1.1.1 – p. 25). This switching always takes place automatically. The presence of increased dynamic loads (such as pneumatic angle grinders, etc.) may lead to an undesirable opening of the transfer relay due to the weakness of the source. To this case, a delay in the opening of the transfer relay can be adjusted with the parameter {1198}.

When the generator stops, the change from transfer mode to inverter mode normally takes place without any interruption of the output voltage. The interruption will be 40 ms in the event of the immediate loss of input voltage at "AC IN" provided the UPS mode {1435} is not deactivated.

#### 6.2.3.1 Type of detection of AC input loss (UPS)

When the WPC is connected to the public grid or to a generator supplying stable and clean AC voltage, the type of detection of input loss {1552} can be selected to "fast". In this mode, perturbation or lack of voltage of less than 1 millisecond can be detected, switching the unit in inverter mode immediately.. This mode guarantees a zero or maximum of 15 ms transfer time

This mode should not be used in presence of highly disturbed utility grid or with a low power generator or a generator supplying a poor quality voltage. In that case the parameter {1552} will be set on "tolerant". In the XTS model, this can be selected by positioning the UPS slide switch (20) in "off" position. The tolerance of this mode is adjustable with the parameter {1510} if required.

The "tolerant" UPS mode insure a interruption time of max. 20 milliseconds.

In rare cases, due to the low quality of the source, and if the transfer relay switches too frequently, it is possible to further reduce the sensitivity of detection AC input loss of by changing the parameter {1552} to "slow" via remote control RCC-02/03. In this case, the interruption of power will be 40 ms max



If the WPC is connected to a generator, this must have a power at least equal to half of the power of the WPC(s) to which it is connected.

### 6.2.3.2 Limiting the AC input current "Input limit"

#### Principle

In order to best use the resources available at the input (depending on the generator size or the grid output) and to protect the source from overload, it's possible to adjust the limit of the input current with the parameter {1107}.

The WPC will automatically distribute the available power to the charger and the user and supply the balance of power if the load demand exceeds the fixed limit thanks to the current assistance function so called "smart boost".



Due to the current assistance feature, the battery can be fully discharged despite the presence of the grid or the generator! The average power consumed by the user must not exceed the power of the source, at the risk of discharging the battery.

This system proves to be a decisive advantage particularly in all mobile systems (boats, leisure vehicles and service vehicles) that are frequently connected to sources with a limited value such as a portable or camping power supply. Despite a limited source, all the greater power applications downstream of the WPC remain functional.

Despite a limited source, all loads connected downstream the WPC remain functional!

The system will reduce automatically the charging current– from its target value {1138} to 0 – according to the current used at the output and the the maximum current available at the input set by the parameter {1107}. The greater the current at the output, the more the part of the current at the input assigned to charging the battery is reduced. If the current exceeds the limit {1107}, the WPC will supply the balance current from the battery.

The wiring of the system (cable gauge) must take into account this particular function which allow to have the sum of the current supplied by the inverter plus the current supplied by the source,

i.e. If the system have a 5kW source (22A) and a 3.5 kW WPC, the available power at the output is 8.5kW! In this example, the wire gauge must be chosen for 38A.

#### Exceeding input limit current:

If, despite the decrease in current from the charger and using the source current assistance the limit is exceeded, the transfer relay will remain activated and the source may then be overloaded, causing the opening of the protective device upstream.

Exceeding the limit may be prohibited by the parameter {1436}. In this case, if the current exceeds the limit {1107}, the transfer relay will open and the user then powered exclusively by the inverter, as long as the output current exceeds the current limit input. If the input current limit is exceeded due to a short circuit downstream, the transfer relay will remain activated and the protective device upstream of the WPC (H) will trip.

#### Second value of input current limit:

The second value of the input limit, is activated when AC input is available on the Generator input, which activated the command entry. This command entry is programmable by the parameters {1566} (Use a different value for the maximum current of the AC source) and {1567} (Second maximum current of the AC source).

- 7  The WPC-PSCP/RCC remote control must be used in order to be able to adapt the value of the input current limit if necessary, for each connection to a limited grid.

### Deactivation of the source assistance function (Smart Boost)

With this feature the source current assistance ("smart boost" can be disabled by setting {1126}.

### Automatic reduction of the current limit input

When the device is connected to a low power or variable speed generator like the GV-7i or Belt Power, the voltage of the generator may (temporarily) fall down before it reaches rated power. To compensate partially this side effect, the WPC has a system of automatic reduction of the input current limit, if the voltage drops beyond a threshold set by the parameter {1309}+ {1433 }, to fall to zero when it reaches the value set by parameter {1309}. This avoids overloading the generator and too frequent transition of the transfer relay.

This feature is also used when a variable power sources is connected to the input of the WPC. This is particularly the case of 230Vac alternators like the BeltPower coupled to drive motors whose speed varies. These devices have their source voltage decrease depending on the available power. A correct setting of thresholds {1309} and {1433} ensures continuous power output with the "Smart Boost"

This feature is by default disabled through {1527} assuming the Grid AC input of the WPC is normally connected to a public network. It is standard enabled for the Generator AC input through parameter {1554}.

### Setting the current "Input limit"

The maximum input current can be adjusted by the remote control WPC-PSCP/RCC. The parameter {1107} is part of the basic parameters of the device and must be adjusted at commissioning depending on the capacity of the source as follows:

- If the device is connected to a network: the value is sized according to the upstream protective device (fuse or circuit breaker) or a lower value if desired.

- If the device connected to a generator, the following empirical formula can be used:  $0.75 \times P_{nom} / U_{ac}$ .

Since the performance of a generator is highly dependent on the installation, the right setting must always be verified for each installation. Thermally, the generator must be able to continuous supply the load with corresponds to the chosen input limit setting.

## 7.1.1 Battery charger

### 7.1.1.1 Working principle

The battery charger for the WPC is completely automatic and is designed in such a way as to guarantee an optimum charge for the majority of the lead-acid or gel batteries. Once the transfer relay is activated, the battery charger goes into operation and the charge indicator (44) lights up.

The charging process is at 3 levels (I/U/Uo) as described by figure below.

this process guarantees optimum charging of the batteries. The charging current is given by the parameter {1138} and can be adjusted continuously from 0 to the nominal value with the help of the WPC-PSCP/RCC.

All times and threshold can be adjusted with the remote control unit.



If the battery voltage is lower than the critical disconnection threshold {1488} operation of the charger will be automatically prevented. Only the transfer relay is authorised to operate in this case. The battery must then be recharged by an external source up to a voltage higher than the critical disconnection threshold in order to allow the WPC charger to operate.

The charge cycle, programmed by default, as shown in the example described in the figure opposite, runs automatically. The line (28) indicates the development of the battery voltage. The lower line (29) indicates the battery current (input and output).

The cycle starts with a continuous current charge (a) adjusted by default according to the parameter {1138}. If the ambient temperature is increased or the ventilation blocked, the current may be reduced and become lower than the selected current.

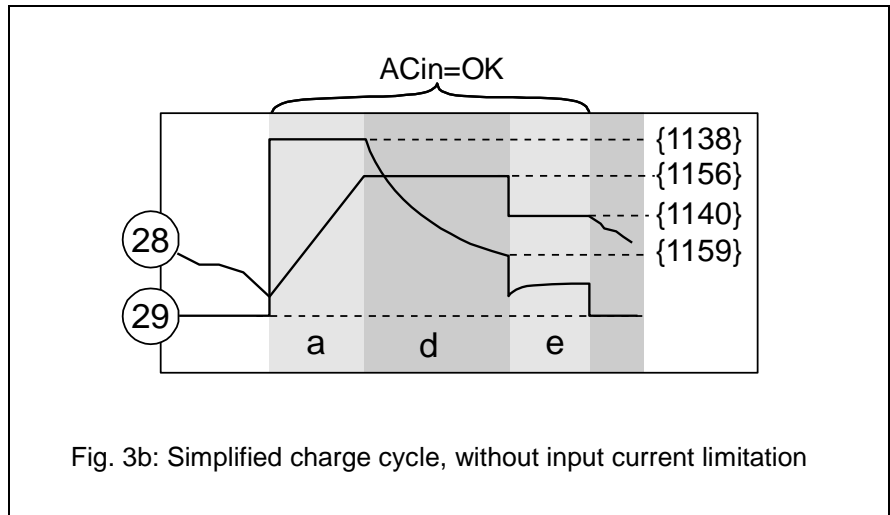
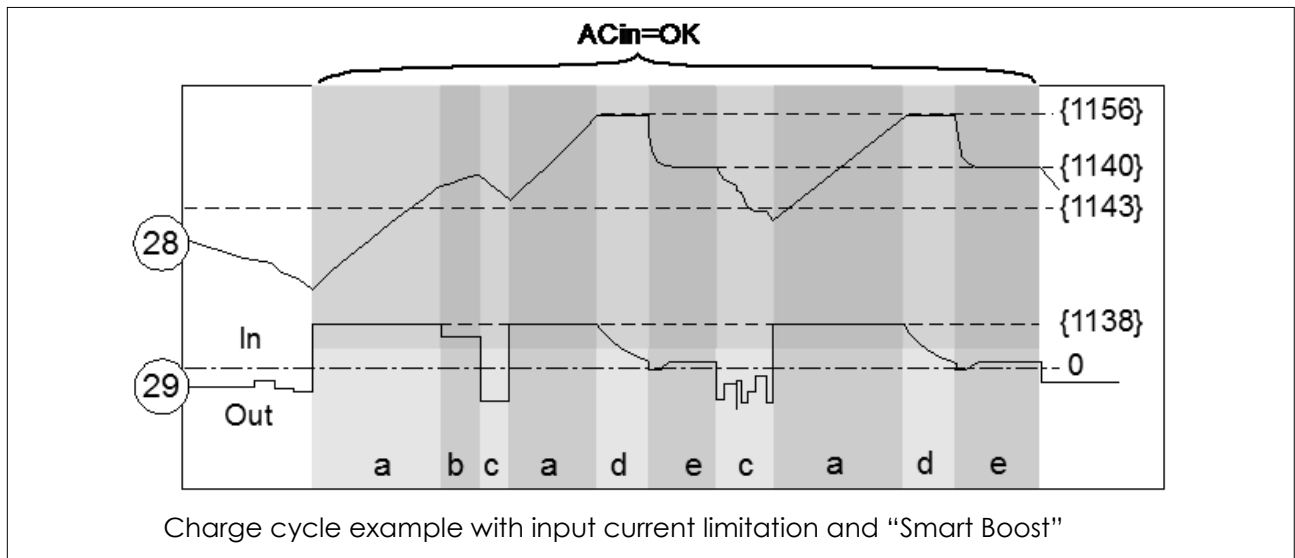

Fig. 3b: Simplified charge cycle, without input current limitation

Once the absorption voltage {1156} is reached, the cycle passes to voltage adjustment mode (d), known as the absorption phase, the duration of which is set by the parameter {1157}. The minimum interval between two absorption cycles is limited by the parameter {1161}. At the expiry of the absorption time, or if the absorption current is lower than the parameter {1159}, the voltage is set to a lower value {1140}. This phase (e) is known as the maintenance or "floating" phase. Due to the limiting function for the input current (see the above p.22), it is perfectly normal for the charge current to be lower than the selected current if the limit of the AC input current {1107} is reached (b). In this event the AC IN indicator (45) flashes. The charge current will be limited too if the battery voltage ripple is higher than 0,5V/cell.

If the "Smart Boost" function is activated {1126} and the power required by the consumer exceeds the power of the source, the battery will be discharged (c) despite the presence of the grid or the generator. In this case the LED "charge" (4) goes out. The consumers must ensure that they have average consumption that is less than the power of the source (generator or public grid) in order to avoid a complete discharge of the battery. These situations are set out in the figure below.



Charge cycle example with input current limitation and "Smart Boost"

If the BST temperature sensor is used, the voltage adjustment thresholds for the battery are corrected in real time by means of the battery temperature. The value of this correction is set by the parameter {1139} in the parameter table p.Fout! Bladwijzer niet gedefinieerd..



Much more complex charge profiles or exclusion of the charger can be configured using the WPC-PSCP/RCC remote control.





Parameters of the battery charger is under the responsibility of the operator. Incorrect parameter that does not correspond to the charging methods of the battery recommended by the manufacturer may be dangerous and/or considerably diminish the battery service life. If the factory settings are modified, it is imperative that the new values be entered in the parameter table p. 35

### 7.1.1.2 Battery charger current setting:

The maximum charging current can be adjusted by the remote control WPC-PSCP/RCC. The parameter {1138} is part of the basic parameters of the device and must be adjusted at commissioning, depending on battery capacity. It will be chosen in principle a value between 0.1 and 0.2 x the nominal battery capacity C10. (eg 10A for a battery of 100 Ah/C10).

### 7.1.2 Battery protection

The battery is protected in all cases against deep discharge. The indicator (52) flashes once when the battery has reached the disconnection threshold {1108} and the inverter will stop some time after {1190}. This threshold can be dynamically corrected {1191} with an advanced algorithm that computes automatically the battery voltage compensation in function of the instantaneous power. This correction may also be manually fixed {1532} by setting the low voltage disconnection at full load {1109}. These dynamic corrections can be deactivated by setting the parameter {1191}. The inverter will stop immediately if a critically low voltage value set by the parameter {1188} is reached. The inverter will restart automatically when the battery voltage has reached the restarting threshold {1110}.

This restarting threshold {1110} can be automatically readjusted if the parameter {1194} is activated, in order to better protect the battery against repeated cycling in an "almost empty" state of charge. The restarting threshold is then incremented {1298} up to a maximum value {1195}, whenever the LVD (low voltage disconnection) is reached. The restarting threshold will be reset to its initial value when the value of parameter {1307} is reached.

If the inverter is repeatedly {1304} encountering a low voltage disconnection in a short period {1404}, it will stop permanently and will only start again via an operator's manual restart.

### 7.1.3 WPC protection

The WPC is protected electronically against overloads, short-circuit, overheating and reverse current (cabling of a voltage source on AC out).

In the event of overload or short-circuit at the output, the inverter stops for some seconds {1533} {1400}, and restarts. If the inverter is repeatedly encountering this situation {1300} in a short period, it will stop permanently and will only start again via an operator's manual control.

If the battery voltage exceeds the value set by the parameter {1121} the inverter stops and starts up again when the voltage is less than {1110}. If the WPC is repeatedly encountering this situation {1303} in a short period {1403}, it will stop permanently and will only start up again via an operator's manual control.



A battery voltage greater than 1.66 x the nominal voltage may lead to significant damage or destroy the device.

Overheating of the WPC, Insufficient ventilation, increased ambient temperature or obstructed ventilation may lead to overheating of certain internal components of the unit. In this case, the device will automatically limit its power output as long as this abnormal situation persists.

The WPC must be protected from reverse polarity by means of an external fuse installed on the battery.

## 8 MULTI-UNIT CONFIGURATION

Several WPC's can be used in the same system, either to create a three-phase system or to increase the power output of a single or two phases. The implementation of this configuration requires particular precautions and it must be installed and commissioned by qualified personal only.



When multi-unit system is commissioned, the software's version of every unit will be automatically checked and units may refuse to start in case of incompatibility. If so, an upgrade of every units is be required with the PSCP/RCC and the last software version available by the manufacturer. (Read the PSCP/RCC user's manual to perform this operation).



In Multi-units system every WPC in the system shares the same battery bank.



In multi-unit system, it is recommended to use the automatic LVD dynamic compensation. See parameter {1532}

In configuration with several WPC's, each unit is controlled independently using the ON/OFF push button (41). When the on/off control is given by the remote control, it is applied simultaneously to all units.

### 8.1.1 Three-phase system

Three WPC's of the same voltage can be used and combined in order to establish a three-phase grid. When 3 WPC's are wired to form a three-phase grid, the wired phases at the input determine the jumper position for selecting the phase (10). It is vital to determine and select the phase for each WPC. If the grid is not available at the input of the master unit (phase 1), all the units of the system will switch to inverter mode. If only a single-phase source is available, it must be connected to phase 1. The other two phases will therefore be supplied by the other two working units in inverter mode.

### 8.1.2 Increasing the power by paralleling units

Up to three WPC's of same type - power and voltage- can be wired in parallel in order to increase the system's rated power output. In this configuration, all the ACin inputs(of the same type, gen or grid) of the WPC must be wired with the same input phase. Also the ACout outputs should be wired in parallel. The most recent unit (according to the serial number) in the phase will act as the master and will decide on the operation or suspension of the units in parallel according to the consumer's power demand. The yield of the installation is therefore still optimal.

It is possible to deactivate the master/slave mode with the parameter {1547}. In that case, the load search mode is disabled.



If the current of the source (per phase) is greater than 30A, a protective device max. 30A, must be installed on each of the 2 or 3 devices connected to the same phase. If the power source is limited to 30A, only one device is common enough.

### 8.1.3 Combined system

It is possible to combine a three-phase system with one or several phases made up of 2 or 3 WPC's in parallel. A combination of more than one inverter on only one (or two) phase is also possible. for example, it's possible to build up one powerful phase for the most single phase consumer and the 2 other phases with only one WPC each for the 3 phase (motor) application. It is therefore possible to combine up to nine WPC's by running three WPC's in parallel in a three-phase grid. The wiring should be comply with the above paragraphs.

### 8.1.4 Enlargement of an existing installation

Only subject to compatibility, it is most of the time possible to enlarge an existing installation by adding one or several inverters in parallel or in a threephase configuration. The compatibility of the new units must be checked by giving Whisper Power the serial numbers of the inverters in the existing installation.



The inverters belonging to the same system must be equipped with the same software version. Take care to download the latest software version from manufacturer's website and do update all units of the system before the commissioning.

## 8.2 ACCESSORIES

### 8.2.1 Control centre and display WPC-RCC/PSCP (remote control)

A WPC-RCC/PSCP remote display and programming unit can be optionally connected to the WPC via one of the two RJ45-8-type "Com. Bus" (3) connectors.

These connectors may only be used for connecting a WPCbus compatible accessory, excluding any other connection such as LAN, Ethernet, ISDN, etc.

The WPC-RCC/PSCP control centre is vital for modifying the parameters of the system.

It also allows the following functions:

- Display of function synopsis
- Display of the measured operational values (current / voltage / power output, etc.)
- Updating of software or implementation of customised software
- upload/download of inverter/charger parameter
- Updating of inverter parameters
- Events logging of error message

The features of the WPC-RCC and the WPC-PSCP are the same. They only differ in their external appearance. The WPC-RCC is designed for stand-alone operation, whereas the WPC-PSCP is designed as a combined device.

Model N°: WPC-RCC: Dimensions: H x W x D // 130 x 120 x 42.2mm

WPC-PSCP: Dimensions: H x W x D // 195 x 120 x 55mm



The two remote control models are delivered with a 15 m cable by default. (article no 60201032)

Up to 3 WPC-RCC/PSCP remote controls can be connected in series on the communication bus of one WPC or an WPC multi-inverter system. In a system comprising a single WPC, the connection of the WPC-RCC or WPC-PSCP may be conducted without stopping the WPC (hot pluggable). When connecting an WPC-RCC/PSCP remote control in a multi-unit system, it is recommended that all units in the system be stopped and that the communication bus on the device on which the connection is being made be terminated.



The 2 switches for the communication bus termination, "Com. Bus" (4) both remain in position T (terminated) except when both connectors are in use. In this case, and only in this case, both must be placed in the O open position. If one of the two connectors is not in use, the two termination switches (14) will be in position T.



WPC-PSCP

### 8.2.2 BTS-01 temperature sensor

The optimal operating voltages for lead batteries vary depending on the temperature. A temperature sensor is optionally available to correct the battery voltage and guarantee an optimum charge whatever the battery temperature. The correction factor given by the correction of the sensor is set by the parameter {1139} Article no. for the temperature sensor (including a cable of 3 m): BTS-01. Dimensions: H x W x D // 58 x 51.5 x 22 mm.



## 9 CONTROL

### 9.1 DISPLAY AND CONTROL PANEL

The WPC has a ON/OFF button and light indicators at the front of the unit, allowing clear identification of the operating mode.

(41) The ON/OFF button allows the start-up or complete stop of the system. In the systems comprising several units, each unit is started or stopped individually or with the ON/OFF button of the WPC-RCC/PSCP remote control.

	<p>Even when the equipment has stopped, dangerous voltages may be present at the WPC input.</p>
--	---

(42) This indicator lights up when the equipment has been stopped manually using the ON/OFF button (41). It also allows the cause of an unintentional stoppage of the device to be indicated via the different flashes, the imminence of a stoppage or the temporary limitation of its performance. The table below describes the type of fault according to the number of flashes on the indicator (42)

Indicated alarm	Comment
1x (Imminent) stoppage as a result of low battery voltage.	If the device has not yet stopped, it is recommended to disconnect all non-priority consumers and/or start up the generator. If the WPC has stopped it will restart automatically when the battery voltage has reached the correct value again {1110}. It can be restarted manually using the ON/OFF button (41) as long as the battery voltage is higher than the critical threshold {1488}. See also chapter 7.1.3 – p. 25.
2x Stoppage due to overload in the equipment, due to either a short-circuit or too high a load for the inverter.	In this event the equipment will make several attempts restart {1300} every few seconds and will stop if the overload remains (see chap. 7.1.3 – p. 25). It is vital to eliminate the cause of the overload without restarting. Restarting is carried out manually by pressing the button (41).
3x Decrease in the rated output of the device due to a too high internal temperature.	This may be due to to great a load for the device, at too high an ambient temperature or counteracted or obstructed ventilation. The power output of the device will therefore be limited to around 50% of the Pnom. including in charger mode or Smart Boost mode.

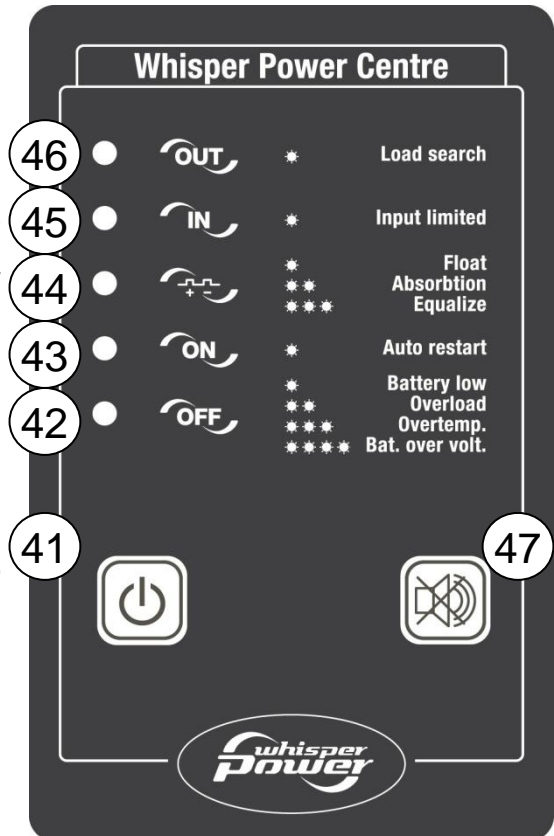

CONTROL

- |    |  |   |
|----|--|---|
| 4x | Battery voltage higher than the maximum limit set by the parameter {1121}.                 | Check the cause of this excess voltage. The equipment will restart automatically when the voltage falls below the threshold value {1122}.<br>see chap. 7.1.3 – p. 25  |
| 5x | No transfer.<br>Insufficient power from the source   | In this case, the WPC remains in operation in inverter mode until the output power decrease below the input limit and does not allow the transfer relay to close. You must increase the input current limit {1107}, or authorise the exceeding of this limit {1436} or authorise backup on the source {1126}, or disconnect some consumers (decrease of loads). |
| 6x | Startup prevented due to unwanted voltage at the device output.                            | Voltage is present at the device output. Check your cabling: correct the fault and start the installation again using a manual control on the button (41).  |
| 7x | Indicates missing voltage on one of the units of the system in a multi-unit configuration. | Check the input protection devices (H) for all the system units.  |
| 8x | Software incompatibility in a multi-units system   | The software version of all units in the system must be harmonised. Proceed according to the WPC-RCC/PSCP user manual to upgrade the software.  |
| 9x | Loss of synchronization between the units  | Failure of the link between the units. Check the presence and the state of the communication cables between units.  |

**(43)** This indicator is glowing continuously when the device is working. It flashes when the equipment is temporarily stopped due to a fault displayed by the indicator (42) or a ON/OFF control wired at the "Remote ON/OFF" input (7).

	<p>The equipment will restart automatically when the conditions that led to the temporary stoppage have gone away.</p>
---	--

In the systems with multiunit's in parallel, the indicator (43) blinks 2 times when the WPC is temporarily stopped by the master unit of the concerned phase while this mode is authorized. {1547}.

**(44)** This indicator is glowing continuously when the charger is working and has not yet reached his absorption phase. It flashes twice during the absorption phase and once during the floating phase. If the Smart Boost mode has been activated, this indicator goes out temporarily when source backup is required by users (loads).

**(45)** This indicator is glowing continuously when an alternative voltage with correct values, either in frequency {1112-1505-1506}, or in voltage {1199} is present at the AC IN input of the device and the current limit set by the user has not been reached. It flashes one time when the current limit at the input {1107} set by the user has been reached. In this case the charger current is reduced in order to guarantee priority supply to the users (see chap. 1.1.1 p. 25). If the input current is exceeded nevertheless, the WPC goes back to inverter mode (transfer relay open) and the indicator (42) will keep flashing as long as the user



current exceeds the limit value of the input current {1107}.

If the Smart Boost mode (see chapter 1.1.1 – p.25) is used and the inverter is part of the user supply – therefore the battery is discharged – the “charge” indicator (44) will be glowing.

If grid feeding is allowed {1127} this indicator is blinking 2 times while feeding.

**(46)** This indicator is glowing continuously when an alternative voltage of 230V is present at the equipment output. It flashes when the device is in “load search” mode according to chapter 6.2.2 – p. 21.

**(47)** Receipt button to stop the acoustic warning. The duration of the acoustic alarm {1565} is factory settled to 0 sec (deactivated).

## **10 MAINTENANCE OF THE INSTALLATION**

With the exception of the periodic checking of connections (tightening and general condition) the WPC does not require any special maintenance.



## 11 PRODUCT RECYCLING

The model of the WPC series conform to the European directive 2002/95/EC on hazardous substances and does not contain the following elements: lead, cadmium, mercury, hexavalent chrome, PBB or PBDE.

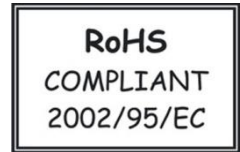

To dispose of this product, please use the service for the collection of electrical waste and observe all applicable obligations according to the place of purchase.

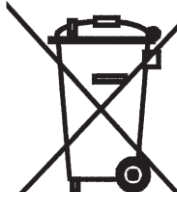





## 12 EC DECLARATION OF CONFORMITY

In accordance with EN ISO 17050-1:2004

The inverter and accessories described in this manual comply with the following directive and standards:

Dir. 2004/108/EEC:  
EN 61000-6-1, EN 61000-6-3, EN 55014, EN 55022, EN 61000-3-2, 62040-2,  
LVD 2006/95/ EEC :  
EN 62040-1-1, EN 50091-2, EN 60950-1.

Signed by:



Name: Dr. R.E.Bosman,

Technical Director,  
Drachten

Date: June 2011

## 13 CONTROL AND DISPLAY PARTS FOR THE WPC (FIG. 4B)

See chapter 9.1 - p. 29.

Pos.	Denomination	Description	Comments
41		ON/OFF button	The ON/OFF button allows the start up or complete stoppage of the system such as it has been programmed. When there are several units in the same system, each unit must be started up or stopped individually using this button.
42	OFF	Light indicator for stoppage of the unit	When the light indicator flashes it indicates the cause of the stoppage of the unit, its imminent stoppage or the limitation of its rated power output according to chapter 9.1 - p.29.
43	ON	Light indicator showing that the equipment is in operation	This indicator is glowing continuously when the device is working. It flashes when the equipment is at a temporary stop. Note: The equipment will restart automatically when the conditions that led to the temporary stoppage have gone away.
44	Charge	Light indicator showing that the battery is being charged	This indicator is glowing continuously when the charger is in operation and has not yet reached the absorption phase. It flashes twice during the absorption phase and once during the maintenance phase. If Smart Boost mode has been activated it is possible that this indicator will go out temporarily when source backup is required by users. (See chapter 1.1.1 - p. 25)
45	AC in	Light indicator showing the presence of correct and synchronised input voltage	This indicator is glowing continuously when an alternative voltage with correct values is present at the AC IN input (13) of the device and the current limit {1107} set by the user has not been reached. It flashes when this limit is reached (see chapter 1.1.1 – p. 25).
46	AC out	Light indicator showing the presence of a voltage at the output	This indicator is glowing continuously when an alternative voltage of 230V is present at the device output. It flashes when the device is in “load search” mode due to the absence of users. (See chapter 6.2.2 – p. 21)
47		Stop acoustic alarm	Note: The acoustic alarm duration {1565} is factory set at 0 sec. and is so deactivated.



## 14 TABLE OF FACTORY'S (DEFAULTS) PARAMETERS SETTINGS

No. of config	Denomination / description	Units	Fact. value	Mo d. value
1107	Maximum current of the AC source	A	16	
1108	Under voltage of the empty battery	V/cell	1.93	
1109	Sub-voltage of the charged battery	V/cell	1.75	
1110	Restart voltage of the inverter after under voltage of the battery	V/cell	2	
1111	Automatic startup at power up	y/n	no	
1112	Inverter frequency	Hz	50/60	
1121	Maximum DC voltage for stopping the WPC	V/cell	2.84	
1126	Source assistance (Smart Boost) permitted	y/n	yes	
1127	Grid feeding allowed	y/n	No	
1138	Battery charge current	A	45	
1139	Battery voltage correction according to the temperature	mV/°C/ cell	-4	
1140	Battery maintenance voltage	V/cell	2.27	
1143	Voltage 1 to allow a new battery cycle	V/cell	2.1	
1144	Duration of under voltage 1 to allow a new cycle	min.	30	
1145	Voltage 2 to allow a new battery cycle	V/cell	2.05	
1146	Duration of under voltage 2 to allow a new cycle	sec.	60	
1156	Battery absorption voltage	V/cell	2.4	
1157	Duration of absorption	h	2	
1159	Current at end of absorption	Adc	10	
1161	Minimum interval between absorptions	h	2	
1167	Wave max. of the battery in charger mode (V/cell)	Vdc	0.5	NC <sup>2</sup>
1187	Sensitivity of the charge detection (100% approx.25W)	%	10	
1188	Number of pulse load research	--	1	
1189	Time interval between load search pulses	sec.	0.8	
1190	Duration of under voltage of battery before disconnection	min.	3	
1191	Dynamic compensation for under voltage	y/n	Yes	
1194	Battery adaptive low voltage allowed	o/n	no	
1195	Max voltage for adaptive low voltage	V/cell	2.08	
1198	Time elapsing before transfer relay opens	sec.	8	
1199	AC in voltage causing the opening of the transfer relay	Vac	180/90	
1200	Immediate open critical threshold for the transfer	Vac	110/55	
1246	Auxiliary contact 1 activated by voltage 1 {1247} after delays {1248}	y/n	yes	
1247	Voltage 1 under which auxiliary contact 1 is activated	V/cell	1.97	
1248	Delays on voltage 1 to activate auxiliary contact 1	min.	1	
1249	Auxiliary contact 1 activated by voltage 2 {1250} after delays {1251}	y/n	Yes	
1250	Voltage 2 under which auxiliary contact 1 is activated	V/cell	2	
1251	Delays on voltage 2 to activate auxiliary contact 1	min.	10	
1252	Auxiliary contact 1 activated by voltage 3 {1253} after delays {1254}	y/n	Yes	
1253	Voltage 3 under which auxiliary contact 1 is activated	V/cell	2.03	
1254	Delays on voltage 3 to activate auxiliary contact 1	min.	60	
1255	Voltage for deactivation of Aux 1	V/cell	2.27	
1256	Delays on voltage {1255} to deactivate auxiliary contact 1	min.	120	
1258	Auxiliary contact 1 activated by power 1	y/n	yes	
1259	Power 1 above which auxiliary contact 1 is activated	%	70	
1260	Duration of power 1 for activating auxiliary contact 1	min.	15	
1261	Auxiliary contact 1 activated by power 2	y/n	yes	

<sup>2</sup> Setting NC=Factory not changeable



TABLE OF FACTORY'S (DEFAULTS) PARAMETERS SETTINGS

1262	Power 2 above which auxiliary contact 1 is activated	%	100	
1263	Duration of power 2 for activating auxiliary contact 1	min.	5	
1264	Auxiliary contact 1 activated by power 3	y/n	yes	
1265	Power 3 above which will be activated auxiliary contact 1	%	110	
1266	Duration of power 3 for activation of auxiliary contact 1	min.	1	
1286	Output voltage	Vac	230/120	
1288	Dynamic compensation of the thresholds (AUX.1)	y/n	no	
1298	Increment step of the adaptive low voltage method	mV/cell	17	
1300	Number of overloads permitted before definite stoppage	--	3	NC <sup>3</sup>
1303	Number of battery over-voltages accepted before final stop	--	3	NC <sup>3</sup>
1304	Number of battery under-voltages permitted before final stop	--	3	
1307	Reset voltage for adaptive correction	V/cell	2.2	
1309	Minimum ACin voltage to authorize battery charging	Vac	220	
1403	Period for counting battery over-voltages	sec.	60	NC <sup>3</sup>
1404	Period for counting battery under-voltages	sec.	0	
1432	Maximum ACin voltage to switch to inverter mode	Vac	250/135	
1433	Adaptation range of the charge current according to the input voltage	Vac	5	
1435	Immediate detection of input voltage loss (UPS)	y/n	no	
1436	Allow to exceed AC input current without opening the transfer relay	y/n	no	
1470	ACin voltage hysteresis for closing the transfer relay	Vac	10 / 5	NC <sup>3</sup>
1485	Prohibited ground relay	y/n	yes	
1486	Neutral always connected	yes/no	no	
1488	Critical under voltage of the battery	V/cell	1.5	
1505	Delta of higher frequency accepted	Hz	35	
1506	Delta of lower frequency accepted	Hz	15	
1510	Tolerance of fast detection	--	100	
1516	Auxiliary contact 1 deactivated by floating mode	y/n	yes	
1517	Auxiliary contact 2 deactivated by floating mode	y/n	no	
1527	Decrease max input limit current with AC-In voltage	y/n	yes	
1528	Delay before closing transfer relay	Min.	0	
1532	Kind of dynamic compensation (Auto/ Man)	A/M	Auto	
1547	Allow slave stand-by in multi units system	y/n	yes	
1565	Acoustic alarm duration	Sec.	0	
1566	Use a alternate max input current	yes/no	yes	
1567	Second maximum current of the AC source	A	13	

 To modify the parameters, please refer to the operating instructions for the WPC-RCC/PSCP remote control

<sup>3</sup> NC=Factory setting not changeable



# 15 TECHNICAL DATA – WPC

WPC model	2000-12		3500-24		4000-48	
-----------	---------	--	---------	--	---------	--

### Inverter

Rated battery voltage	12V		24V		48V	
Input voltage range	9.5 - 17V		19 - 34V		38 - 68V	
Continuous power @ 25 °C	1500VA	2000 VA	2000VA	3000 VA	2000VA	3500 VA
Smart Boost power	1500VA	2000 VA	2400VA	3500 VA	2600VA	4000 VA
30 minute load @ 25 °C	1500VA	2000 VA	2400VA	3500 VA	2600VA	4000 VA
5 second load @ 25 °C	3 x Pcont.					
Maximum load	Up to short-circuit					
Maximum asymmetrical load	Up to Pnom					
Load detection (standby)	2 to 25W					
Admissible cos phi	0.1 - 1					
Maximum efficiency	93%		94%		96%	
Idle power OFF/standby/ON	1.2/1.4/8W	1.2/1.4/10W	1.4/1.6/9W	1.4/1.6/12W	1.8/2/10W	1.8/2.1/14W
Output voltage	Sin wave 230Vac (+/-2%) / 180-245 Vac or ****Sin wave 120 Vac (+/-2%) / 50-140 Vac					
Output frequency	50 Hz adjustable 45-65 Hz +/- 0.05% (quartz-controlled) ****60 Hz adjustable 45-65 Hz +/- 0.05% (quartz-controlled)					
Harmonic distortion	<2%					
Overcharge and short-circuit	Automatic disconnection then 2 startup attempts					
Overheating protection	Alarm prior to disconnection and automatic restart					

### Battery charger

6-phase battery charger	Programmable I-U-Uo-equalisation-Uo(low)-U(periodic)					
Adjustable charge current	<b>60A/0-70A</b>	<b>60A/0-00A</b>	<b>55A/0-55A</b>	<b>60A/0-90A</b>	<b>30A/0-30A</b>	<b>50A/0 - 50A</b>
Input current limit	<b>32A/ 1 - 50A</b>					
Maximum input voltage	265Vac / ****150Vac					
Voltage range for the AC-IN detection level	Adjustable from 150 to 230 Vac ****Adjustable from 50 to 140 Vac					
Admissible input frequency	45 - 65Hz					
Power Factor Correction (PFC)	EN 61000-3-2					

### Battery control (factory value / adjustable range with WPC-PSCP/RCC)

End of absorption	by duration: <b>2h</b> / 0.25 - 18 h or by current <b>&lt;10A</b> / 2 - 50 A					
Absorption voltage	<b>14.4V</b> /9.5-17V	<b>28.8</b> / 19 - 34V	<b>57.6</b> / 38 - 68V			
Periodic absorption voltage	- / 9.5 - 17V	- / 19 - 34V	- / 38 - 68V			
Floating voltage	<b>13.6V</b> /9.5-17V	<b>27.2</b> / 19 - 34V	<b>54.4</b> / 38 - 68V			
Reduced maintenance voltage	- / 9.5 - 17V	- / 19 - 34V	- / 38 - 68V			
Equalisation	By number of cycles ( <b>NA</b> / - 100) or at fixed intervals ( - / 52 weeks)					
End of equalisation	By duration <b>2h</b> / 0.25 – 10h or by current <b>10</b> / 4 – 30 A					
Equalisation voltage	- / 9.5 - 17V	- / 19 - 34V	- / 38 - 68V			
Low voltage disconnection	<b>10.8V</b> /9.5- 17V	<b>21.6V</b> /19- 34V	<b>43.2V</b> / 38 - 68V			
Reduced floating duration	- / 0 - 32 days					
Periodical absorption	- / 0 - 10 hours					
Temperature compensation	-5 / 0 to -8mV/°C/Cellule (option BTS-01)					



WPC model	2000-12	3500-24	4000-48
<b>General data</b>			
Maximum transfer relay current	30A		
Maximum transfer time	0-15ms (UPS mode)		
Weight	25kg	28kg	28kg
Dimensions: H x W x D [mm]	540*330*150		
Protection degree	IP21		
Conformity	Dir. 2004/108/CE.; LVD 2006/95/ EEC EN 61000-6-1, EN 61000-6-3, EN 55014, EN 55022, EN 61000-3-2, Dir.		
Operating temperature range	-20 to 55°C		
Ventilation	Forced from 45 °C		
Noise level	<40 dB / <45 dB (without / with ventilation)		
Warranty	2 years		

**Options**

Remote control and programming centre for standalone operation: WPC-RCC  
 Remote control and programming centre combined with DDC panel: WPC-PSCP  
 Battery temperature sensor: BTS-01

**15.1 DIMENSIONS**

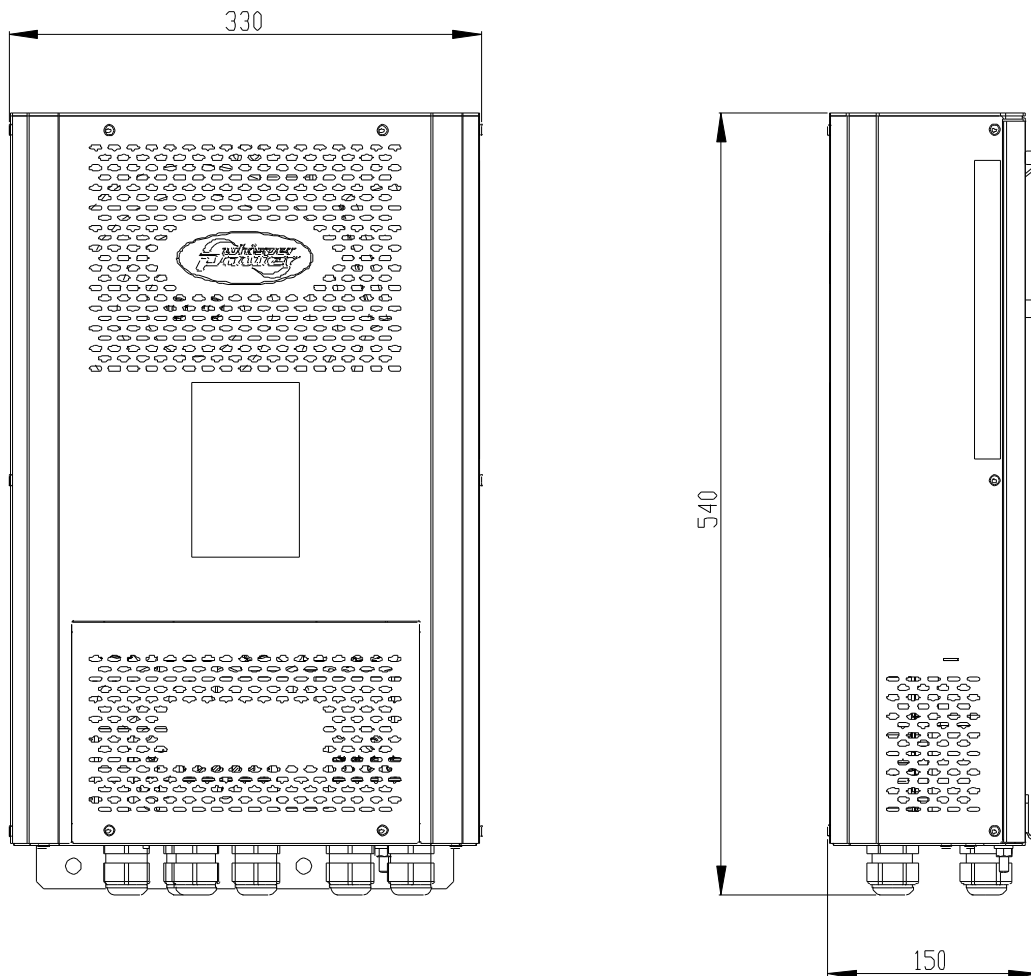

## 15.2 TYPE PLATE

The model indication, operating voltage and currents as well as the serial number of the unit is printed on the type plate which is located on the the left side of the WPC.

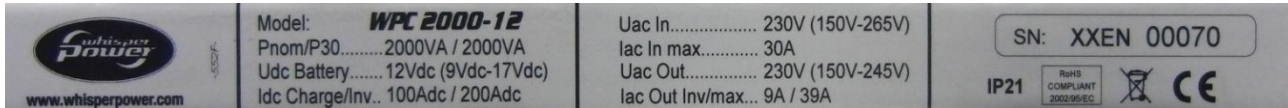

Example type plate for WPC 2000-12 model, serial number XXEN 00070

Denomination	Description	Comments
Model	Model	
Pnom/P30	Rated power output / power for 30 minutes	
Udc Battery	Rated battery voltage (accepted input range)	
Idc Charge/inv	Maximum current in charger/nominal current in inverter	
Uac In	Rated AC input voltage (input range)	See sect. 6.2.3 - 21
Iac In max	Maximum current at input / output	See sect.6.2.3.2 – p.22
Uac Out	Rated output voltage in inverter mode (possible adjustment range in inverter mode)	When the transfer relay is activated, the ac output voltage is equivalent to ac input voltage
I AC Out Inv/max	Maximum AC output current	
SN:xxxxxxxxx	Serial no.	
IPxx	Protection degree according to IEC 60529	



Kelvinlaan 82, 9207 JB Drachten, Netherlands  
Tel : + 31-512-571550 / Fax : + 31-512-571599  
[www.whisperpower.eu](http://www.whisperpower.eu) / [info@whisperpower.nl](mailto:info@whisperpower.nl)