

Air-conditioning system

**Installation and Service
Manual**

**Roof-top
air-conditioning
system CC8**

01/2003

 **Webasto**

Contents

1 Introduction

1.1	Scope and purpose.....	101
1.2	Meaning of Warnings, Cautions and Notes	101
1.3	Additional documentation required	101
1.4	Safety information and regulations	101
1.5	Certification.....	102
1.6	Corrections and improvements.....	102

2 General description

2.1	Roof-top unit	202
2.2	Air distribution panel (standard).....	203
2.3	Air ducting system	204
2.4	Compressor	205
2.5	Electrical system.....	205
2.6	Principle of operation of the roof-top air-conditioning system.....	205
2.7	Design, purpose and principle of operation of the assemblies	207
2.7.1	Condenser.....	207
2.7.2	Receiver-drier	207
2.7.3	Thermal expansion valve.....	207
2.7.4	Evaporator.....	207
2.7.5	Pressure switch	207
2.7.6	Anti-icing thermostat.....	207
2.7.7	Axial fans	208
2.7.8	Radial fans.....	208
2.7.9	Compressor	208
2.7.10	Electronic room thermostat (optional).....	208
2.7.11	Fresh air ventilation flap (optional)	208
2.7.12	Circulating air filter (optional).....	208

3 Technical data

3.1	Air-conditioning system.....	301
3.2	Electrical fuses.....	301
3.3	Compressor	302

4 Installation instructions

4.1	Safety precautions	401
4.2	Standard installation kit.....	401
4.3	Locally manufactured items not included in standard installation kit	401
4.4	Vehicle-specific parts not included in standard installation kit and to be procured locally.....	402
4.5	Installation kits – air ducting system	402
4.5.1	Installation kit, air ducting system.....	402
4.5.2	Extension kit, air ducting system	402
4.5.3	Installation kit, air distribution panel (without air ducting system).....	402
4.6	Required equipment, special tools and accessories.....	403
4.7	Preparations on vehicle / cabin roof	403
4.8	Manufacture / procurement of compressor mounting bracket	406
4.9	Manufacture of hoses	408

4.10	Installation of roof-top unit with air ducting system or air distribution panel	413
4.10.1	Air duct sealing	413
4.10.2	Working on the sealing frame	414
4.10.3	Mounting the base frame	415
4.10.4	Pre-assembly of air distribution panel	416
4.10.5	Installation of air distribution panel	417
4.10.6	Installation of air ducting system	417
4.11	Installation of compressor	419
4.12	Make electrical connections	420
4.13	Preparation and installation of refrigerant lines and condensation water hoses in the vehicle	421
4.14	System leak-testing and evacuation	422
4.14.1	General	422
4.14.2	Description of test gauges with fittings	422
4.14.3	Evacuation	422
4.15	Filling the system with refrigerant	423
4.15.1	General	423
4.15.2	Main filling	423
4.15.3	Leak-testing	423
4.15.4	Complementary filling	424
4.16	Completion	424
5	Operating information	
5.1	Safety precautions	501
5.2	System control	501
5.3	Controls and indicators	502
5.4	First-time operation	502
5.5	Operating instructions	503
5.6	Operation of air-conditioning system (with room thermostat function and fresh air ventilation flap).....	503
6	Maintenance	
6.1	Safety precautions	601
6.2	General	601
6.3	Maintenance and service	601
6.4	Maintenance and service checklist	602
6.5	Inspections before repair	602
6.6	Troubleshooting	603
6.6.1	General	603
6.6.2	Electrical system	603
6.6.3	Air-conditioning system	603
6.6.4	Refrigerant circuit	604
6.6.5	Pressure testing	604
6.7	Repairs	604
6.8	Post-repair procedures and testing	605
6.8.1	Check refrigerant pressures and pressure switches function tests	605
6.8.2	Replenishing partially filled systems with refrigerant	606
6.9	Visual inspection	606
7	Circuit diagrams	701
8	Torque values for some spare parts	801
9	Warranty claims	901

List of illustrations

201	Roof-top air-conditioning system CC8	201
202	Roof-top unit	202
203	Air distribution panel	203
204	Air ducting system.....	204
205	Compressor versions	205
206	Functional schematic	206
401	Preparations on vehicle / cabin roof.....	404
402	Compressor, permissible installation position	407
403	Universal compressor mounting bracket.....	408
403A	Install the clip system	410
404	Making up the hoses	412
405	Testing hoses for leaks	412
406	Roof sealing	413
407	Sealing frame of Armaflex/Eurobatex sealing profiles	414
408	Baseplate attachment	415
409	Air distribution panel, pre-assembly	416
410	Air duct frame.....	419
411	Air ducting system.....	419
412	Condensation hose connections	421
501	Controls.....	502
701	Circuit diagram, basic version	701
702	Circuit diagram, thermostat version	702
703	Circuit diagram, fresh air and thermostat version	703

1 Introduction

1.1 Scope and purpose

This installation and service manual contains important information to assist trained personnel in the installation, operation and maintenance of the roof-top air-conditioning system CC8.

1.2 Meaning of Warnings, Cautions and Notes

WARNINGS, CAUTIONS and NOTES in this manual have the following meaning:

WARNING

This heading is used to highlight that non-compliance with instructions or procedures may cause injuries or fatal accidents.

CAUTION

This heading is used to highlight that non-compliance with instructions or procedures may cause damage to equipment.

NOTE

This heading is used to highlight and draw specific attention to information.

1.3 Additional documentation required

- Operating instructions for the roof-top air-conditioning system CC5/CC8

1.4 Safety information and regulations

The roof-top air-conditioning system CC8 has been designed and built in accordance with the EC Directives.

The system can be operated safely when installed and operated properly in accordance with the installation and service manual.

If the vehicle height specified in the vehicle's licensing documents is exceeded by installation of the roof-top air-conditioning system, this must be legalized by an official acceptance inspection in accordance with Section 19 of the German Road Traffic Licensing Regulations (StVZO).

The following general and operational safety regulations for the prevention of accidents must be observed at all times.

- Safety regulations for the manufacture and operation of earth-moving machinery published by the foundation works association (Technischer Aufsichtsdienst (Technical Supervisory Services), Landsberger Str. 309, 80687 München)
- DIN ISO 3471 Roll-over protective installations
- DIN ISO 3449 Protective installations against falling objects
- DIN ISO 3411 Machine operator's body size, minimum working space
- Guidelines, safety regulations, rules, principles and data sheets compiled by the technical committees of the Center for Safety and Health – BG7 – of the employers' liability insurance association (published by Carl Heymanns Verlag KG, Luxemburger Str. 449, 50939 Köln)
- Regulations concerning the driver's or cabin-seated operator's field of view

"General safety regulations" beyond the scope of these regulations are detailed below.

The specific safety regulations applicable to this manual are highlighted in the individual chapters by WARNINGS, CAUTIONS and NOTES.

General safety regulations

Non-compliance with the installation manual and its procedures will void the Webasto warranty. The same applies to unskilled repairs or repairs not using original spare parts. This may also cause void the vehicle's "general permit for operation".

If additional material not supplied by Webasto is used in the passenger cabin, care must be taken to ensure that all materials used meet the statutory requirements in respect of flammability.

Electrical wiring and operating elements of the air-conditioning system must be arranged in the vehicle in such a way that their correct functioning cannot be impaired under normal operating conditions.

Safety instructions for maintenance

If faults develop in the refrigerant circuit, the system must be tested and repaired by an authorized specialist repairshop. Under no circumstances may refrigerant be discharged into the atmosphere (refer to Section 8 of the regulation dated 6 May 1991 banning CFCs and halones).

- Never heat refrigerant cylinders with a naked flame.
- Avoid skin contact with liquid refrigerant. Observe the safety data sheet.
- Always wear protective clothing and goggles when handling refrigerant.

WARNING

Do not perform soldering or welding directly on components of the closed refrigerant circuit or in its vicinity. The considerable increase in temperature will increase the pressure in the circuit and it may explode.

Before starting any work on the system, it must be allowed to cool down completely to avoid skin burns caused by the hot condenser, compressor or hoses.

Installation, maintenance and repairs may only be carried out by skilled personnel with the engine and power supply switched off.

The battery must be disconnected before opening the roof-top air-conditioner, removing the compressor or starting any work on the electrical wiring.

Do not wear metal jewellery (bracelets, watches, necklaces, rings) when working on the air-conditioning system.

1.5 Certification

- Electromagnetic compatibility (EMC) has been tested and complies with the requirements of standard EN 45014.
- The product complies with the guidelines for CE marking.

1.6 Corrections and improvements

Objections, improvements and proposals for correction of this installation and service manual should be addressed to:

Webasto Thermosysteme International GmbH
Abt. Technische Dokumentation
D-82131 Stockdorf
Telefon: 0 89 / 8 57 94-5 42
Telefax: 0 89 / 8 57 94-7 57

2 General description

The roof-top air-conditioning system CC8 is used for cooling / air-conditioning vans and small passenger buses.

The system is available in three versions: a basic version, a version with thermostat control and a deluxe version with additional fresh air ventilation flap. All versions can be fitted with an air distribution panel or air ducting system.

The air-conditioning system consists of the roof-top unit (1, Fig. 201), the compressor (2), the air distribution panel (Fig. 203) and an optional air ducting system (Fig. 204).

The roof-top unit and the compressor are connected to a refrigerant circuit via hoses.

The electrical power supply is provided by the vehicle battery. A 12 Volt or 24 Volt air-conditioning system is available, as required for the vehicle's power supply.

The system is controlled by means of rocker switches and a command value switch (temperature controller) for the optional thermostat control, which may be installed in the air distribution panel or in the dashboard.

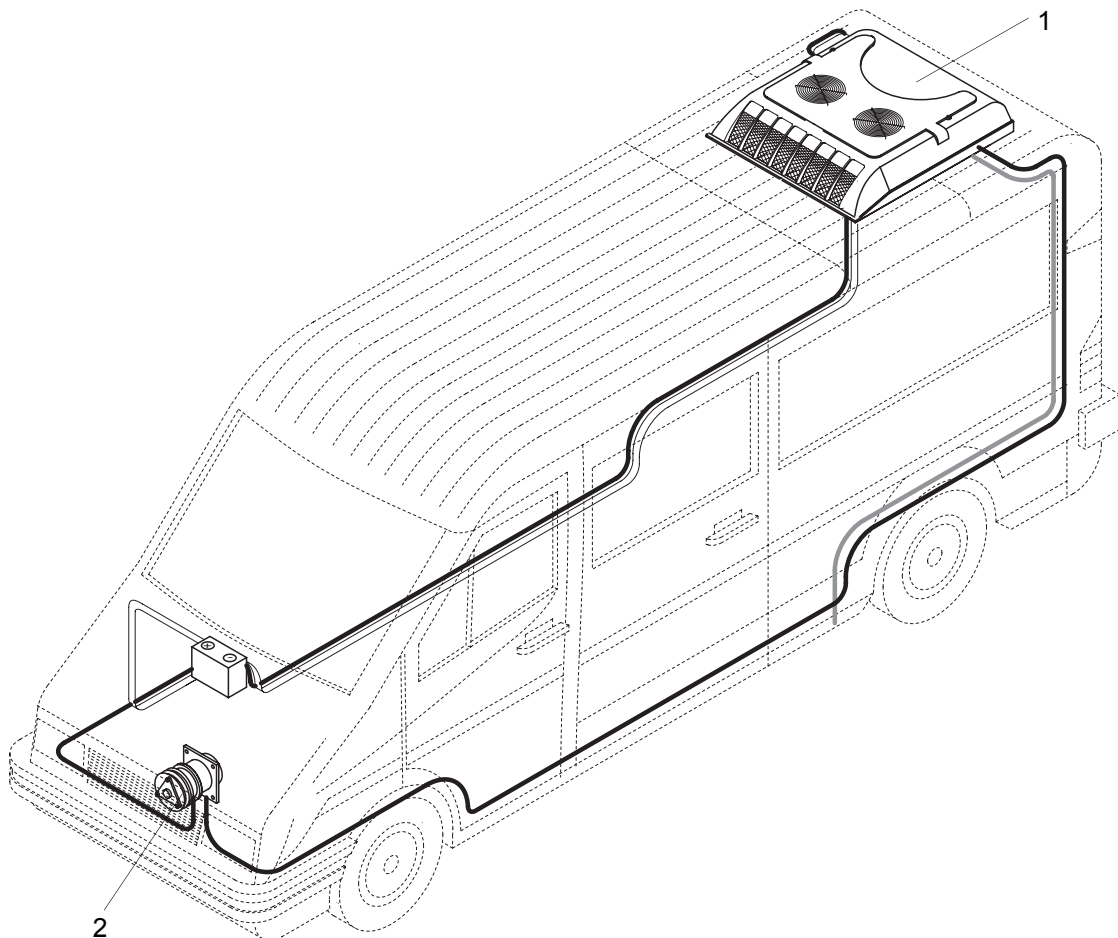

Fig. 201 Roof-top air-conditioning system CC8

NOTE

Vehicles to be equipped with a roof-top air-conditioning system must have an auxiliary drive belt pulley for the compressor or be prepared to receive a compressor in their main belt drive installation.

2.1 Roof-top unit

The roof-top unit is shown in Fig. 202.

It comprises:

- A hood as cowling with openings and protective screens for air inlet and outlet.
- A baseplate on which the various parts are mounted.

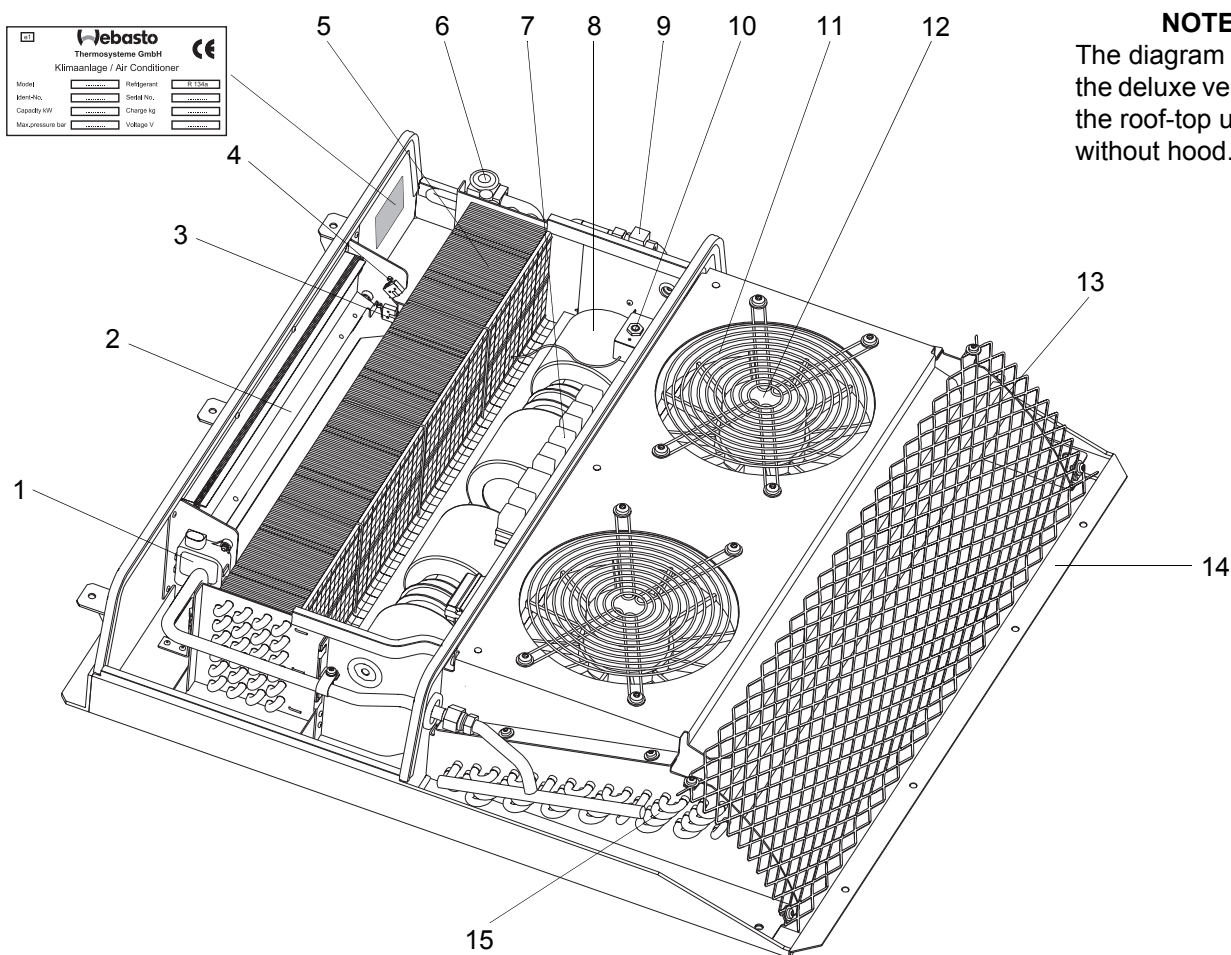

- | | |
|--|---------------------------------------|
| 1* Flap motor | 8 Radial fan 2x |
| 2* Fresh air ventilation flap | 9 Receiver-drier with pressure switch |
| 3* Microswitch, fresh air (OFF) | 10 Anti-icing thermostat |
| 4* Microswitch, fresh air (ON) | 11 Protective screen, axial fan |
| 5 Evaporator with mist separator | 12 Axial fan 2x |
| 6 Thermal expansion valve | 13 Protective screen, air inlet |
| 7 Electrical distribution with relays, flat fuse holder and optional thermostat module | 14 Base frame |
| | 15 Condenser |

*) optional

Fig. 202 Roof-top unit

2.2 Air distribution panel (standard)

Air can be distributed via the air distribution panel (Fig. 203). When installing the panel, the system controls may be mounted directly on the panel or integrated in the dashboard via the (optional) wiring harness for external controls.

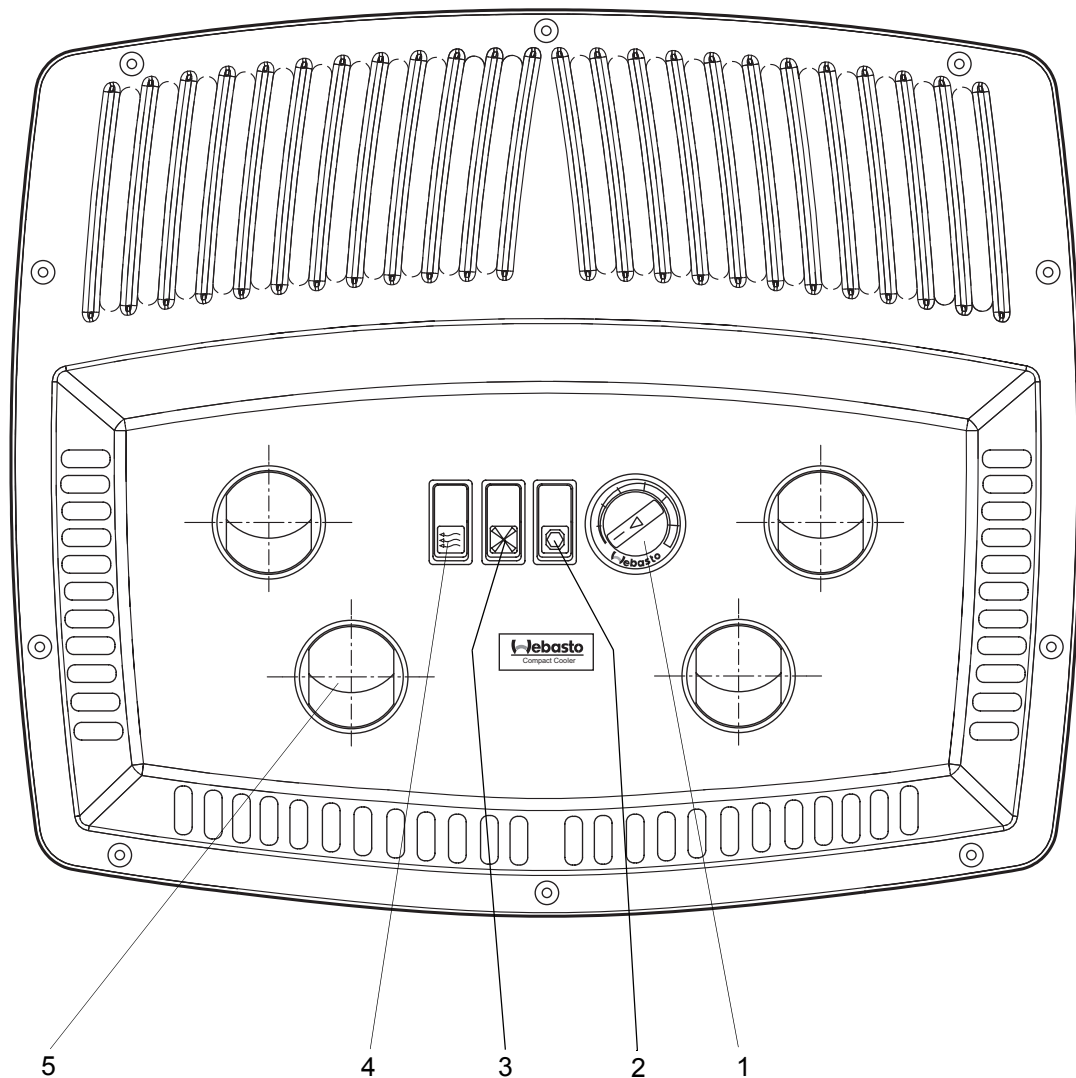

- 1 Command value switch (temperature controller) (optional)
- 2 2-position rocker switch, Air-conditioner ON / OFF
- 3 3-position rocker switch (fan setting)
- 4 2-position rocker switch (fresh air ventilation flap) (optional)
- 5 Rotary air nozzles (4x)

Fig. 203 Air distribution panel

2.3 Air ducting system (option)

The modular air ducting system (Fig. 204) can be installed in the vehicle to distribute air. The system comprises an air distribution panel, the central air duct and the end air duct. Several central air ducts may be installed, depending on the required length of the air distribution system.

The modules of the air ducting system are mounted on a frame, which is in turn secured to the cabin ceiling or roof arches. The frame consists of frame segment(s), the frame end and the segment connectors.

The system controls are mounted on the dashboard when installing the air ducting system. The wiring harness for "external controls" is required for this purpose.

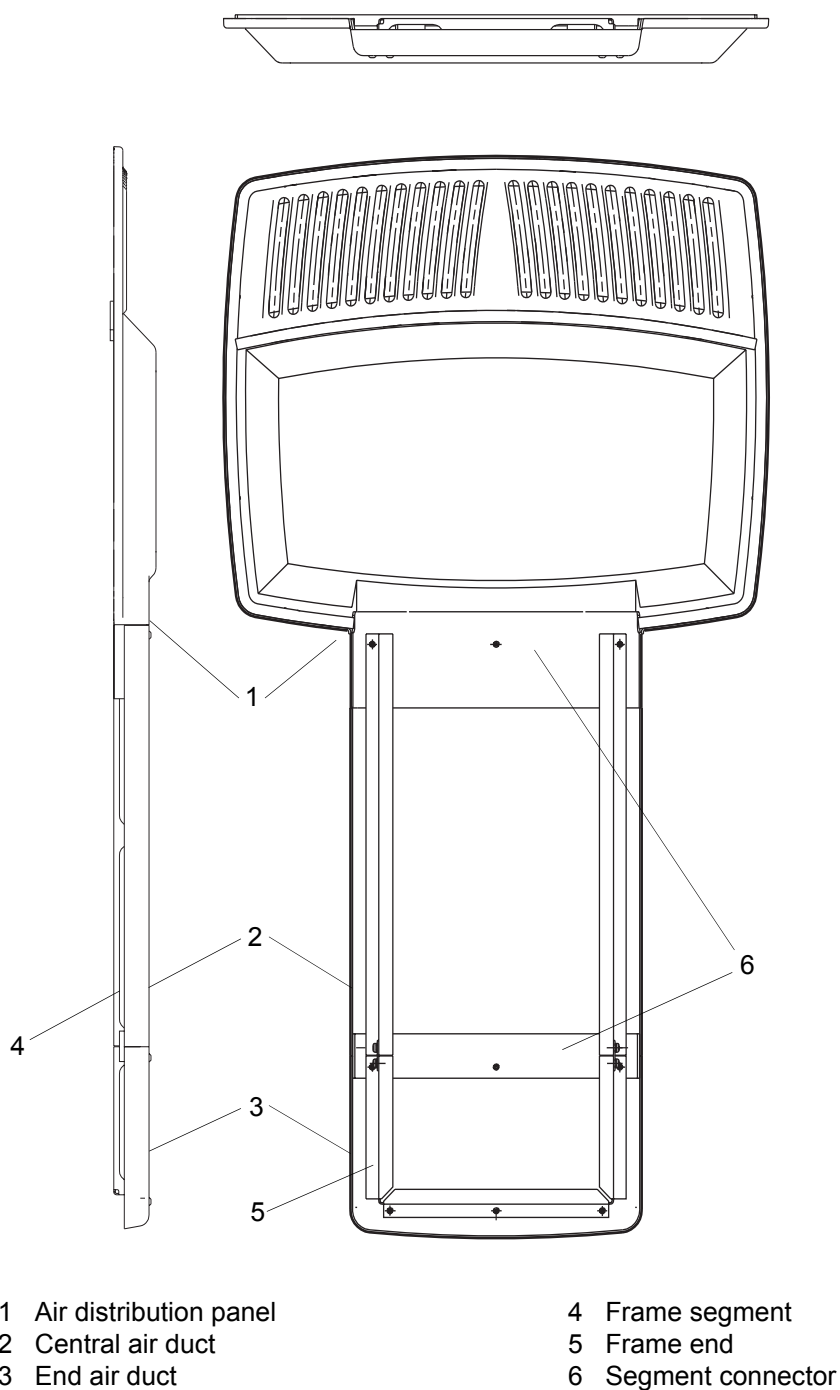

Fig. 204 Air ducting system

2.4 Compressor

The compressor (Fig. 205), a swashplate compressor, is available in eight versions:

- TM-16HD h, with horizontal refrigerant connections and twin V-belt pulley, 12 V
- TM-16HD h, with horizontal refrigerant connections and twin V-belt pulley, 24 V
- TM-16HD v, with vertical refrigerant connections and twin V-belt pulley, 12 V
- TM-16HD v, with vertical refrigerant connections and twin V-belt pulley, 24 V
- TM-16HD v, with vertical refrigerant connections and Poly V8 belt pulley, 12 V
- TM-16HD v, with vertical refrigerant connections and Poly V8 belt pulley, 24 V
- TM-16HD v, with horizontal refrigerant connections and Poly V8 belt pulley, 12 V
- TM-16HD v, with horizontal refrigerant connections and Poly V8 belt pulley, 24 V

NOTE

For the relevant order number refer to the price list.

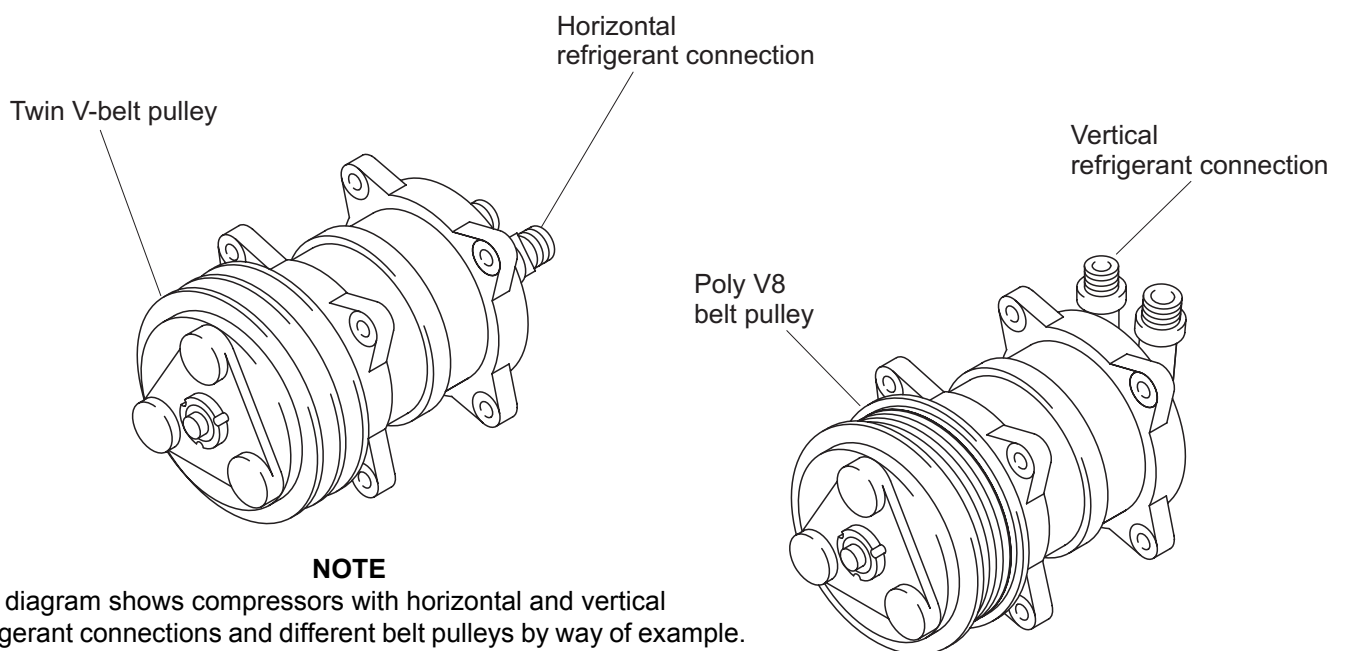

NOTE

The diagram shows compressors with horizontal and vertical refrigerant connections and different belt pulleys by way of example.

Fig. 205 Compressor versions

2.5 Electrical system

The electrical connection of the air-conditioning systems is shown in the circuit diagrams, Figs. 701 to 703.

Connection should be made across a battery discharge protection circuit with fuse. In this configuration, the air-conditioning system can only be operated with the engine running.

A main fuse rated as shown in the circuit diagrams (Figs. 701 to 703) must be installed in all cases.

2.6 Principle of operation of the roof-top air-conditioning system

When the air-conditioning system is switched on via the ON / OFF rocker switch, the compressor (13, Fig. 206) engages via the magnetic clutch and is driven by the V-belt of the vehicle engine. The compressor compresses the refrigerant gas and supplies it to the condenser (11), where the gas condenses and dissipates heat.

The external air (8 and 12) flowing through the condenser takes up the heat produced by condensation. Two axial fans (9) maintain a sufficient air flow even when the vehicle is stationary.

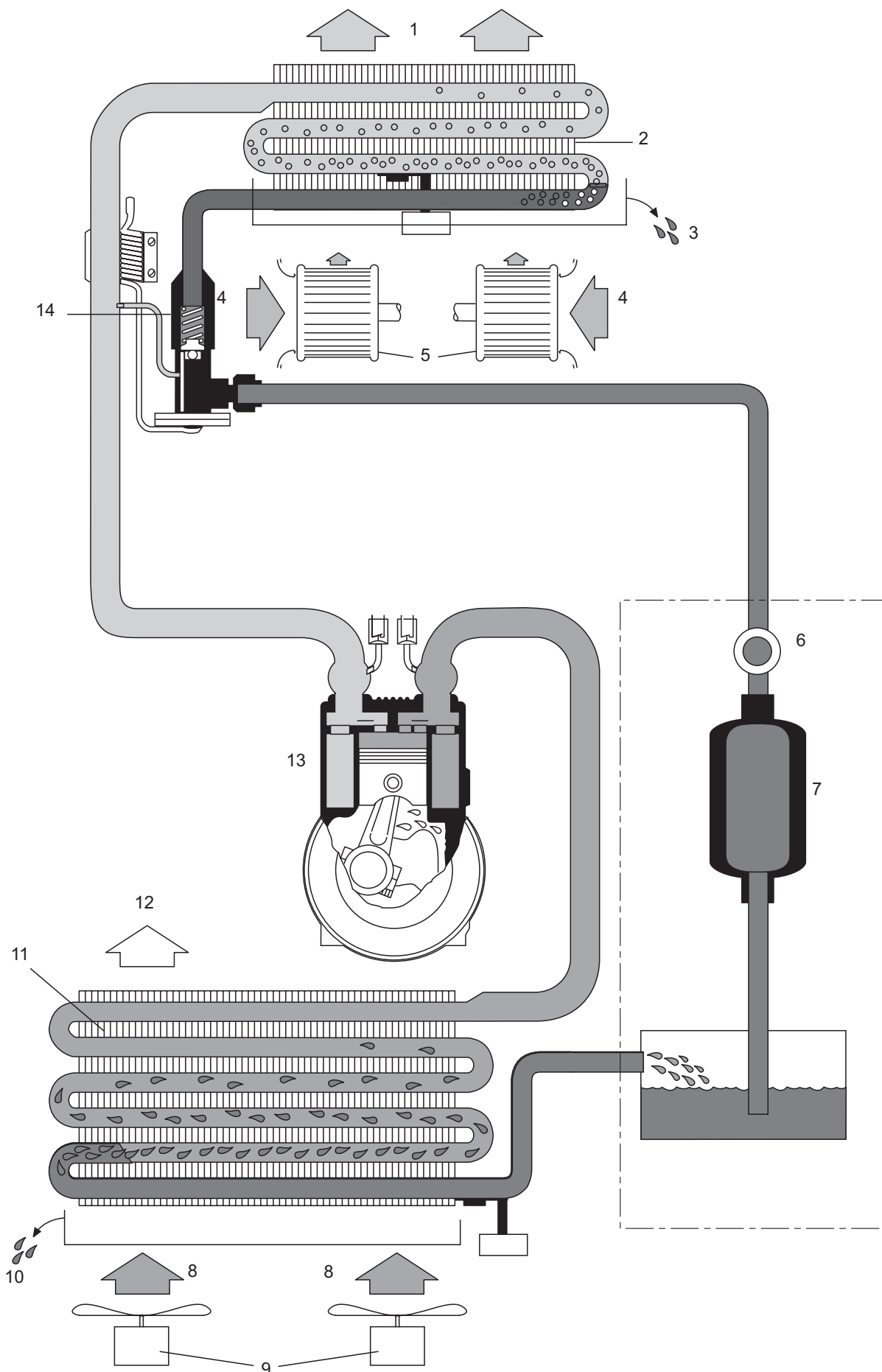

Fig. 206 Functional schematic

As the liquid refrigerant flows through the receiver-drier (7) to the expansion valve (14), it decompresses with the controlled drop in pressure and returns to the gaseous state in the evaporator (2), absorbing considerable heat at the same time.

The warm air (4) circulating in the cabin is drawn in by the radial fan (5), cooled in the evaporator, dried and returned to the cabin via the air ducting system or the air distribution panel (1). Accumulated condensation water is separated out and routed to the exterior by means of drain hoses.

During operation, the refrigerant circuit is monitored via an anti-icing switch and a pressure switch. These two switches control the magnetic clutch to engage and disengage the compressor.

When the air-conditioning system is switched off via the ON / OFF rocker switch, the magnetic clutch and fan motors are de-energized, and the refrigerant and air circuits are deactivated.

The open design of the roof-top unit allows rainwater entering its wet area to drain from the vehicle roof.

2.7 Design, purpose and principle of operation of the assemblies

2.7.1 Condenser

The condenser (15, Fig. 202) consists of a continuous pipe coil and fins interconnected to form a large heat exchanger surface.

The condenser cools the hot refrigerant gas so that it condenses and undercools. The condensation heat is transmitted via the fins to the outside air flowing through the condenser.

2.7.2 Receiver-drier

The receiver-drier (9, Fig. 202) with viewglass is a refrigerant compensation and reservoir vessel. Its lower part contains a granulated desiccant which extracts and chemically binds small amounts of water from the refrigerant. This reduces the risk of ice forming on the expansion valve and protects the compressor against damage. During operation, the viewglass is used to check that there is sufficient refrigerant in the circuit.

2.7.3 Thermal expansion valve

The thermal expansion valve (6, Fig. 202) controls the refrigerant flow to the evaporator in accordance with the refrigerant required or the temperature in the evaporator. The expansion valve is a control element between the low and the high pressure sections of the refrigerant circuit.

2.7.4 Evaporator

The evaporator (5, Fig. 202) is basically of the same design as the condenser. The refrigerant flowing through the pipe from the expansion valve changes from the liquid to the gaseous state and superheats in the evaporator.

The required evaporation heat is extracted from the cabin air flowing through the fins and is transmitted through the pipe to the refrigerant. The air dries as it cools and condensation water is drained overboard. A mist separator prevents droplets of condensation water being drawn in by the radial fan and entering the cabin interior.

2.7.5 Pressure switch

The pressure switch contains a high and a low pressure switch. It monitors the pressure conditions in the high-pressure section of the refrigerant circuit and switches the compressor off by disengaging the magnetic clutch if the pressure is too low (e.g. due to loss of refrigerant) or too high (e.g. overheating of condenser).

2.7.6 Anti-icing thermostat

The anti-icing thermostat (10, Fig. 202) is a temperature switch which measures the temperature between the fins of the evaporator and disconnects the power supply to the magnetic clutch if there is a risk of ice forming (approx. 0 °C). The power supply is reconnected at approx. + 3 °C.

2.7.7 Axial fans

Each axial fan (12, Fig. 202) includes a single-stage DC motor. After switching the air-conditioning system on, they are constantly driven by the vehicle's electrical system via a relay to supply the condenser with the required outside air.

2.7.8 Radial fans

Each radial fan (8, Fig. 202) contains a multi-stage DC motor. Cabin air is drawn in by the radial fans and passed through the evaporator before being returned to the cabin via the air ducting system or the nozzles of the air distribution panel.

2.7.9 Compressor

The compressor (Fig. 205) consists of a swashplate compressor and the magnetic clutch with belt pulley. The compressor is switched on and off by means of the magnetic clutch when the air-conditioning system is in operation.

Its rate of flow depends on the engine speed, but is set to ensure a sufficient flow even with the engine idling. When in operation, it compresses the refrigerant to the required condensation pressure.

2.7.10 Electronic room thermostat (optional)

The deluxe version and the thermostat version have an integrated electronic room thermostat and temperature sensor. The intake temperature of the circulating air is measured. The compressor is deactivated when the temperature set on the command value switch is reached.

2.7.11 Fresh air ventilation flap (optional)

The deluxe version includes a fresh air ventilation flap which can be operated with a rocker switch. Control is performed by microswitches (4, Fig. 202) which deactivate the flap motor when the limit position is reached. A fresh air filter is provided to trap dirt particles in the outside air.

2.7.12 Circulating air filter (optional)

A circulating air filter can be fitted in the circulating air circuit of the roof-top unit to remove any dirt contained in the circulating air.

3 Technical data

3.1 Air-conditioning system

Designation	Type CC8
Dimensions, roof-top unit	1025 mm X 970 mm X 197 mm
– length x width x height	Approx. 40 kg
Weight	12 Volt DC, 24 Volt DC
Operating voltages (depending on vehicle's electr. system)	
Current consumption (air flow unobstructed)	Approx. 45 A / approx. 27 A
– 12 Volt DC / 24 Volt DC	
Switching points, low-pressure switch	
– Off	2.0 ± 0.3 bar
– On	2.1 ± 0.2 bar
Switching points, high-pressure switch	
– Off	22.5 ± 2 bar
– On	15.0 ± 3 bar
Refrigerant	R134a
Refrigerating capacity	8.5 kW ± 10%
Evaporator air flow rate (air flow unobstructed)	1300 m ³ /h
Switching point, anti-icing thermostat	
– Off	1 °C ± 1
– On	3.5 °C (max.)
Fresh air percentage (when stationary)	approx. 20% of evaporator air flow rate

3.2 Electrical fuses

Protected components	Fuse designation	Ratings
12 V / 24 V		
– Axial fans	F1/F2	25 A / 15 A
– Compressor	F3	10 A / 7,5 A
– Radial fans + compressor	F4/F5	20 A / 15 A
– Fresh air ventilation flap motor	F6	1 A / 1 A

3.3 Compressor

Designation	Type Seltec TM16 HD
Dimensions	See Fig. 402 for TM16 HD with horizontal connection
Weight	7.0 kg
Sense of rotation	left / right
Stroke volume per revolution	162.9 cm ³
Lubricating oil for refrigerating compressors (type, quantity)	PAG ZXL 100 PG / 180 + 20 cm ³
Refrigerant connections	
– Delivery side (standard)	3/4" O-ring
– Intake side (standard)	7/8" O-ring
Installation position, range of tilt	
– About longitudinal axis	max. ± 45°
– About lateral axis	max. ± 10°
Magnetic clutch	
– Power supply	12 / 24 Volt DC
– Power consumption	max. 45 Watt (at 25 °C)
– Connector type	AMP 42060
Operational speed (rpm)	700 to max. 6000 rpm
Pressure relief valve opening pressure	34.5 – 39.2 bar abs

4 Installation instructions

4.1 Safety instructions

Read the safety instructions (see 1.4) before starting any work and comply with them.

The system must be installed or the installation work supervised by personnel familiar with vehicle air-conditioning systems.

4.2 Standard installation kit

The standard installation kit includes the following components and materials:

- 6 m refrigerant hose NW 12
 - Discharge line compressor / condenser
- 6 m refrigerant hose NW 16
 - Intake line evaporator / condenser
- 10 m condensation drain hose, 90° Cu bend, hose clamp 16 – 24 mm
- Screw fittings and O-rings for refrigerant hoses
 - 1 x NW 16 90° with filler neck
 - 1 x NW 16 90° with flange
 - 1 x NW 12 90° with filler neck
 - 1 x NW12 90°
 - 0.5 m insulating tape for insulating the screw fitting on expansion valve
- To install the roof-top unit
 - Bolts M8 x 55, washers DIN 9022, washers DIN 125 and self-locking nuts M8, 6 of each
 - Sikaflex sealing compound
 - 5 strips of Armaflex/Eurobatex (34 x 32 x 750) sealing material
 - 6 spacers
 - 1 strip of Armaflex/Eurobatex to protect the condenser against dirt (32 x 25 x 850)

4.3 Items to be manufactured by the customer and not included in standard installation kit

- Air duct seal between the vehicle roof and the air distribution panel
- Electrical cables and elements (on the vehicle) (see Fig. 701, 702 and 703)
- Fastening elements for routing refrigerant hoses and electric cables
- Reinforcing elements, roof bows for the inside of the roof to ensure that the roof is adequately strong

4.4 Vehicle-specific parts not contained in installation kit and to be procured by the customer

- Compressor (can be supplied by Webasto)
- Fastening elements/bracket for installing the compressor, or the universal compressor bracket from Webasto
- V-belt of appropriate size to match V-belt pulley dimensions

WARNING

When selecting a compressor be sure to choose one that has a built-in high-pressure relief valve as a safety feature. All the compressors supplied by Webasto have a relief valve of this type. The relief valve opening pressure must be as specified in the technical data for the compressor (see 3.3).

4.5 Installation kits – air ducting system**4.5.1 Installation kit, air ducting system**

The installation kit for the air ducting system contains the following components:

- 1 air distribution panel
- 1 sealing strip, 15 x 15 mm
- 1 identification plate "COMPACT COOLER"
- 1 air duct end piece
- 1 central air duct
- 1 frame end
- 2 frame segments
- 2 frame connectors
- 6 oval head screws M6 x 16
- 6 washers B6.4 (DIN 9021)
- 6 nuts M6 (DIN 985)
- 12 plastic expanding rivets
- 9 self-tapping screws 4.2 x 32 (DIN 7981)
- 1 expanded rubber strip, 15 x 4 mm

4.5.2 Extension kit, air ducting system

An extension kit is available to suit the desired length of the air ducting system. 1, 2 or 3 extension kits may be installed.

One extension kit for the air ducting system contains the following components:

- 1 central air duct
- 2 frame segments
- 1 frame connector
- 4 oval head screws M6 x 16
- 4 washers B6.4 (DIN 9021)
- 4 nuts M6 (DIN 985)
- 5 plastic expanding rivets
- 1 expanded rubber strip, 15 x 4 mm

4.5.3 Installation kit, air distribution panel (without air ducting system)

- 1 air distribution panel
- 1 sealing strip, 15 x 15
- 4 air nozzles
- 3 closing panels, 44 x 22
- 1 cap, 12.7 x 3.2
- 10 self-tapping screws 4.2 x 32 (DIN 7981)
- 1 identification plate "COMPACT COOLER"

4.6 Required equipment, special tools and accessories

- For installation
 - Sheet metal cutter for cut-outs in the vehicle/cab roof
 - Mechanics tool kit
 - Clip pliers to install the refrigerant hoses
 - Hose shears
- For evacuating, filling and checking the refrigerant circuit
 - Servicing / recycling station for R134a refrigerant
 - Vacuum pump, intake rate min. 5 m³/h, final pressure 1 Torr
 - Filler hoses with fast-action connector for R134a
 - Leak detector
 - Digital thermometer
 - Bottle of R134a refrigerant
 - Recycling bottle for R134a refrigerant
 - R134a bottle connectors
 - Refrigeration oil ZXL PAG 100 for Seltec compressor
 - Test fittings with intake pressure and high pressure gauges
 - Spring balance or scales (min. 35 kg)
 - Nitrogen bottle with pressure reducer.

4.7 Preparations on vehicle/cab roof

The method of installation depends on the type of vehicle. It is therefore essential to refer to the vehicle manufacturer's instructions. In addition, the best position for installation must be selected to suit the contours of the roof.

Fig. 401 shows the installation dimensions and the mounting hole pattern for the roof-top unit. The cut-out for the air outlet is **off-centre** in the base plate. This must be taken into account when positioning the system and the air distribution panel and when making the opening for the intermediate ceiling.

CAUTION

- Be careful not to damage and supporting structures (for example roof bows and reinforcements) or interior fittings, such as screws, mounting brackets or stiffening frames on roof bows.
 - Reinforcing roof bows and large washers should be used if necessary to install the air-conditioning system safely.
1. Remove the intermediate roof layer and any insulation material from the area around the air ducts.
 2. Sketch the air duct cut-outs and holes for condensation hoses (hatched areas in Fig. 401) on the roof, using a template for the roof section (optional, part No. 98500) if necessary.
 3. Align the template or roof-top unit (without cover) and drill six holes with a diameter of 10 mm.
 4. Remove the template or roof-top unit.
 5. Deburr/smooth the edges of cut-outs and holes and treat them with anti-corrosive paint.
 6. Install any roof reinforcements or additional frames required in the vehicle for safe installation of roof-top unit (not supplied).

An installation kit including these roof reinforcements is available for Mercedes Benz Sprinter and Volkswagen LT vans/buses with a medium and long wheelbase and with a high roof, from model year 1996 onwards. Do not use the template mentioned in step 2 in this case.
 7. Prepare the interior of the roof so that the air ducting system or air distribution panel can be mounted on the underside of the roof.
 8. Match spacers to the shape of the roof.

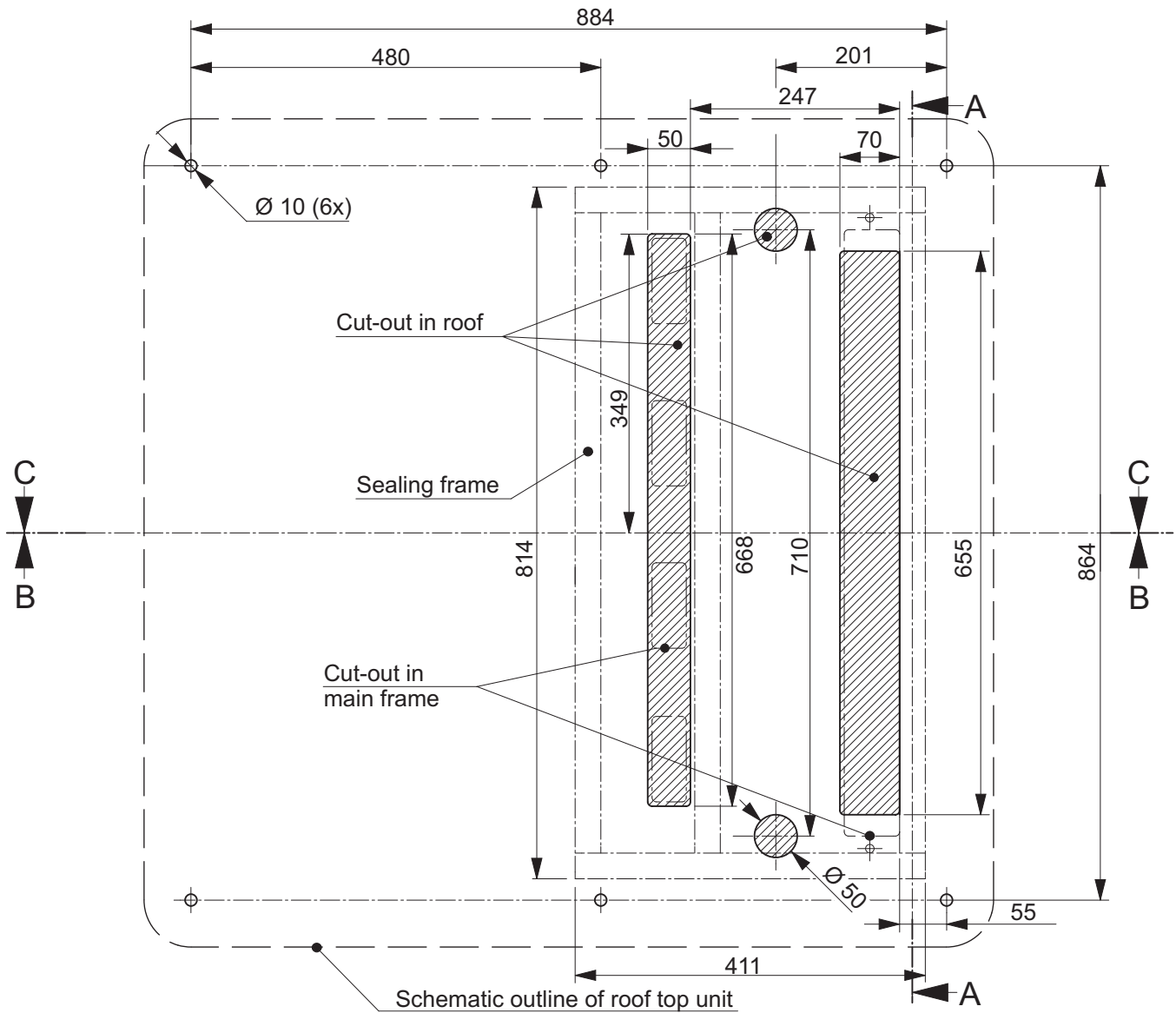

NOTE

The cut-out for the air outlet is off-centre.

NOTE

Section A-A does not show the dirt protection strip

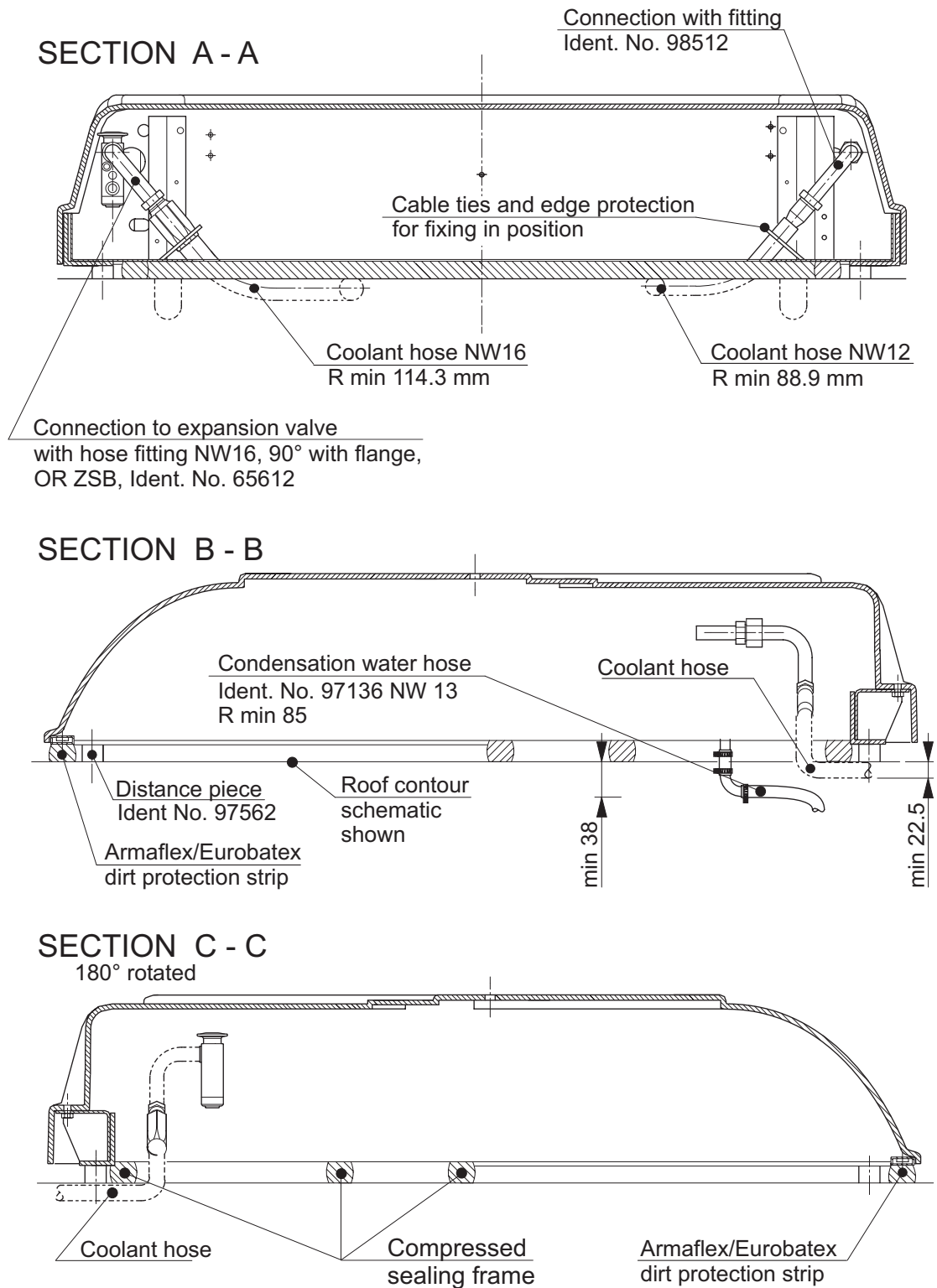

Fig. 401 Preparations on vehicle / cab roof (page 1 of 2)

Fig. 401 Preparations on vehicle / cab roof (page 2 of 2)

4.8 Manufacture / procurement of compressor mounting bracket

Fig. 402 shows the dimensions and attachment points for a TM16 HD compressor with horizontal connection. The connecting dimensions (83.3 and 112) are the same for all compressors (see 2.4).

The compressor must be installed in accordance with the vehicle manufacturer's instructions.

The following points must also be observed when manufacturing / procuring the mounting bracket:

- Check whether compressor mounting brackets can be obtained from the vehicle manufacturer. The vehicle chassis and engine identification numbers specified in the vehicle's registration documents will be required for this purpose.
- Check the availability of the universal compressor mounting bracket from Webasto (Fig. 403) and whether it can be used.
- Permitted installation position of the compressor.
- Choose a V-belt pulley diameter that does not exceed the upper or lower compressor operating speed limits.
- Ensure that V-belt pulleys on the engine and compressor are aligned.
- Sufficient V-belt wrap angle ($> 120^\circ$).
- The compressor must be securely mounted to at least 4 flange holes with a facility to adjust the tension of the V-belt.
- The position of the refrigerant connections and the V-belt pulley dimensions depend on the compressor used.

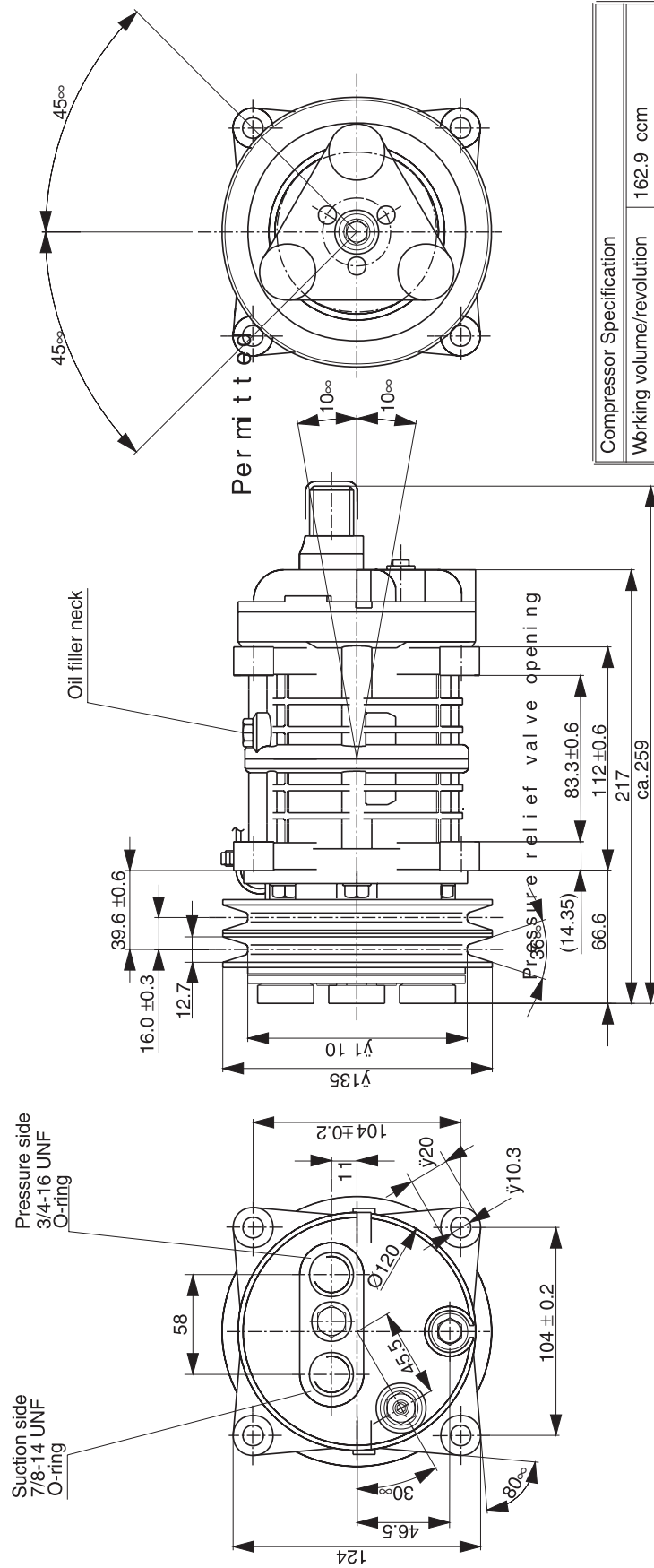

Compressor Specification	
Working volume/revolution	162.9 ccm
Coolant	R 134a
Refrigerator oil	ZXL100PG
Oil quantity	180 ccm + 20
Direction of rotation	right / left
Operating speed range	700-6000 1/min
pressure	34.5 \bar{n} 30 bars
Leak testing	pressure side 30 bar suction side 15 bar
Compressor primed with nitrogen and sealed with sealing caps	
< 14 g/year	

Magnetic Clutch Specification	
max. power consumption	45 W (at 25°C)
Electrical connector	AMP 42060
Transferred torque	35 Nm 49 Nm (after run-in)
Cable color	12 V : black 24 V : green

CAUTION

Comply with the permitted installation positions of the compressor. Non-compliance will result in compressor failure.

Fig. 402 Permitted compressor installation position

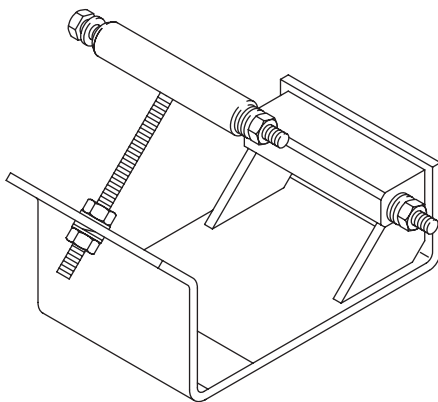

Fig. 403 Universal compressor mounting bracket

NOTE

Use shims to compensate for tolerances exceeding 0.3 mm between compressor mounting bracket and each flange hole on the compressor.

4.9 Manufacture of hose lines

1. Select/determine location/routing of the hose lines (bear the diameter of screwed connections at cut-outs in mind).
2. Cutting hoses to size
 - Measure the hose lengths in the vehicle; make sure there are no sharp bends/kinks (do not exceed the minimum bending radius).
 - Refrigerant hose NW 16 (intake side) should be insulated to prevent the formation of condensation (not included in installation kit).

NOTE

The minimum bending radius for clip connections and refrigerant hose GH134:
Bending radius refrigerant hose NW 12 (R min.: 75 mm)
Bending radius refrigerant hose NW 16 (R min.: 100 mm)

Minimum bending radius for clip connections and refrigerant hose FC 802:
Bending radius refrigerant hose NW 12 (R min.: 89 mm)
Bending radius refrigerant hose NW 16 (R min.: 115 mm)

NOTE

When routing the hoses be sure to avoid narrow bends in vertical direction as refrigerator oil may collect in these bends. This may result in inadequate oil circulation and thus in damage to the compressor, even if the minimum bending radii of the hoses were observed.

- Cut the hoses at right-angles with hose shears or clamp the hose horizontally in a vice with profile protection jaws and saw it at right-angles using a steel saw with fine teeth.
 - Remove residues of rubber and textile reinforcement linings.
3. Fit rubber pads on the cut-outs in the body (edge protectors or cable grommets).

4. Install the fittings

4.1 General notes on the installation process

NOTE

Fit the hose lines with the following connections:

- Intake line: Refrigerant hose NW 16
 - 90° screw fitting with flange O-ring ZSB (on expansion valve),
Tightening torque at flange bolt 5 Nm*
 - 90° screw fitting with O-ring ZSB with filler neck (on compressor),
Tightening torque 35 Nm*
- Discharge line: Refrigerant hose NW 12
 - 90° screw fitting with O-ring ZSB (on condenser),
Tightening torque 36 Nm*
 - 90° screw fitting with O-ring ZSB with filler neck (on compressor),
Tightening torque 26 Nm*

NOTE

As from August 2002, installation kits have been supplied with a clip system. In this case refer to the installation instructions in 4.2.

If you wish to replace the hoses, a refrigerant hose of type FC 802 (fitted with a screw system) may also be affected. In this case refer to the installation instructions in 4.3.

See also: 6.7 Maintenance work.

4.2 Install the clip fitting (Fig. 403A)

- Remove anti-corrosive coatings from metal components (nipples and fitting) using a cleaning product (for example petroleum ether).
- Fit two clips of the appropriate size to the cut end of the hose (1). The direction of the clips has no effect on the performance of the connection. To make the installation work easier, both clips should face in the same direction.
- Coat the nipple with plenty of refrigerant (2). This **must** be done to reduce the force required to insert the nipple.
- Fit the nipple into the hose (3). To ensure that the nipple has been fitted properly, check the gap between the end of the hose and the nipple collar. Do not kink or otherwise damage the hose as you fit the nipple. Remove any excess oil from the nipple and hose.
- Engage the bar in the nipple groove, leave the arms of the bar pointing in the same direction as the hose (4). If the bar is correctly installed it can be rotated relative to the nipple. The bar ensures that the clips are positioned over the O-rings and that the connection will satisfy the pressure requirements, that is why the bar **must** be fitted.
- Position the clips over the arms of the bar in the ducts provided (5).
- Close the clips with the clip pliers (7). Hold the pliers at right-angles to the clip connection points as you do so (6). They should also be at a right-angle when you close the clips.
- Position the jaws of the pliers under the raised section of the clip of the interlock. To make them easier to install, the clips should be closed between the arms of the bar.

* See table of tightening torques for spare parts on page 801

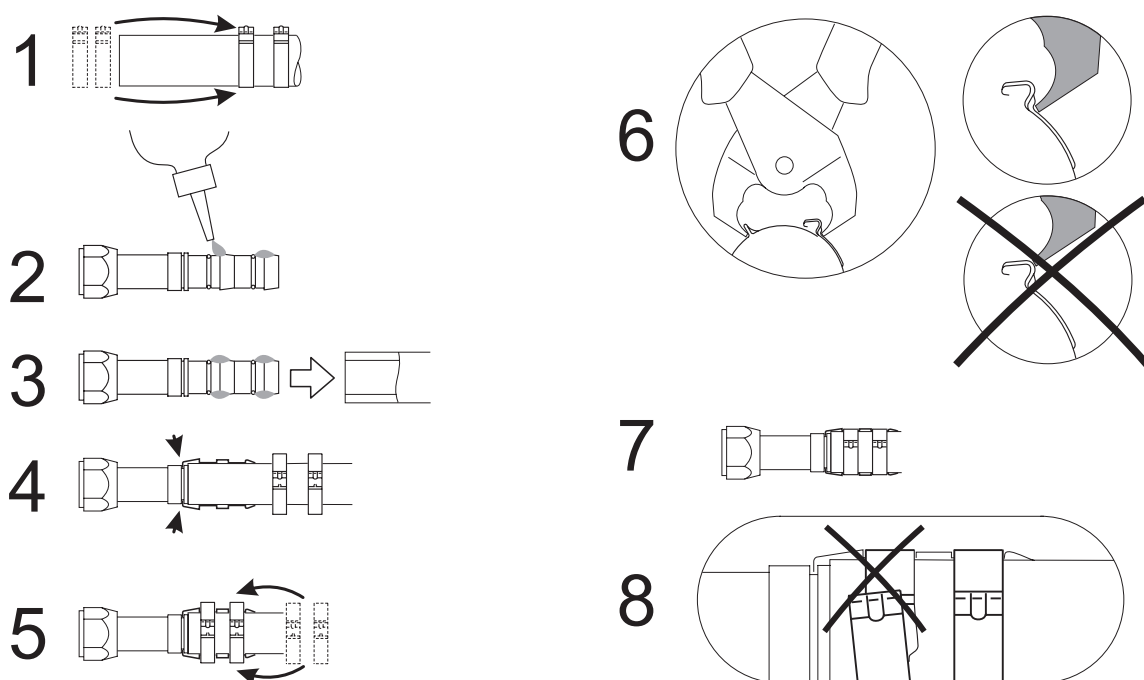

Fig. 403A Install the clip system

NOTE

If you do not hold the pliers at right-angles to close the clips the clips' closure may be slightly out of position (8). In this case correct the clip closure with the pliers.

NOTE

Clip components must not be reused.

- Ensure that the hose is in perfect condition; make sure there are no constrictions or bulges, particularly at the transition to the fitting.
- Blow nitrogen or dry, clean compressed air through the hoses.
- Seal the hoses and check them for leaks in a water bath using nitrogen or dry compressed air (leak test pressure approx. 35 bar) (see Fig. 405).

WARNING

Only carry out this test with the appropriate safety equipment in place.

WARNING

If you fail to follow the installation instructions or use other combinations of hose fittings, you may produce unreliable and unsafe connections, which may result in the sudden or accidental escape of refrigerant gases.

For 4.3 Install the screw system

- Remove anti-corrosive coatings from metal components (nipples and fitting) using a cleaning product (for example petroleum ether).
- Do not strip the hose. Clamp the threaded fitting in place and screw the hose into the socket as far as it will go by turning it anti-clockwise, then turn it back (Fig. 404).
- Apply refrigerator oil (PAG) to the hose inner tube and nipple thread (see figure).
- Holding the nipple at the hexagon, screw it into the socket and the hose by turning it clockwise until there is a gap of approx. 1.0 to 1.5 mm between the hexagon and the socket. Do not tighten it (Fig. 404).
- Ensure that the hose is in perfect condition; make sure there are no constrictions or bulges, particularly at the transition to the fitting.
- Blow nitrogen or dry, clean compressed air through the hoses.
- Seal the hoses and examine them for leaks in a water bath using nitrogen or dry compressed air (leak test pressure approx. 35 bar) (see Fig. 405).

WARNING

Only carry out this test with the appropriate safety equipment in place.

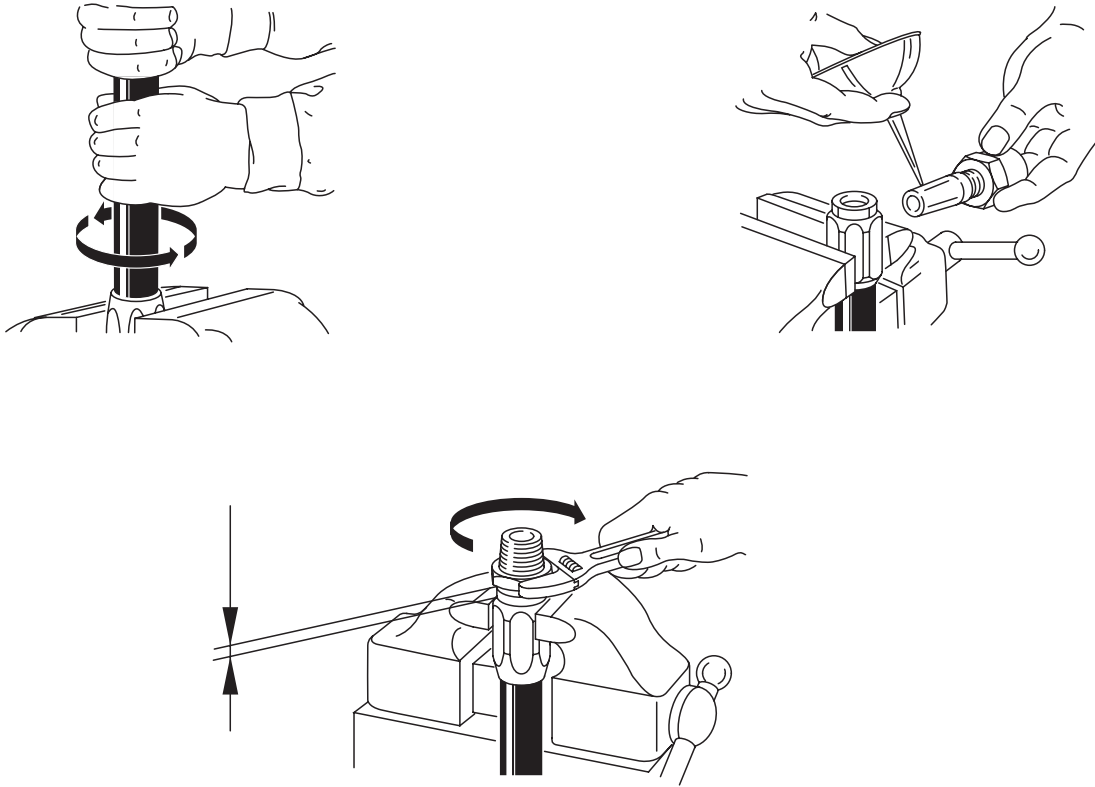

Fig. 404 Making the hose lines

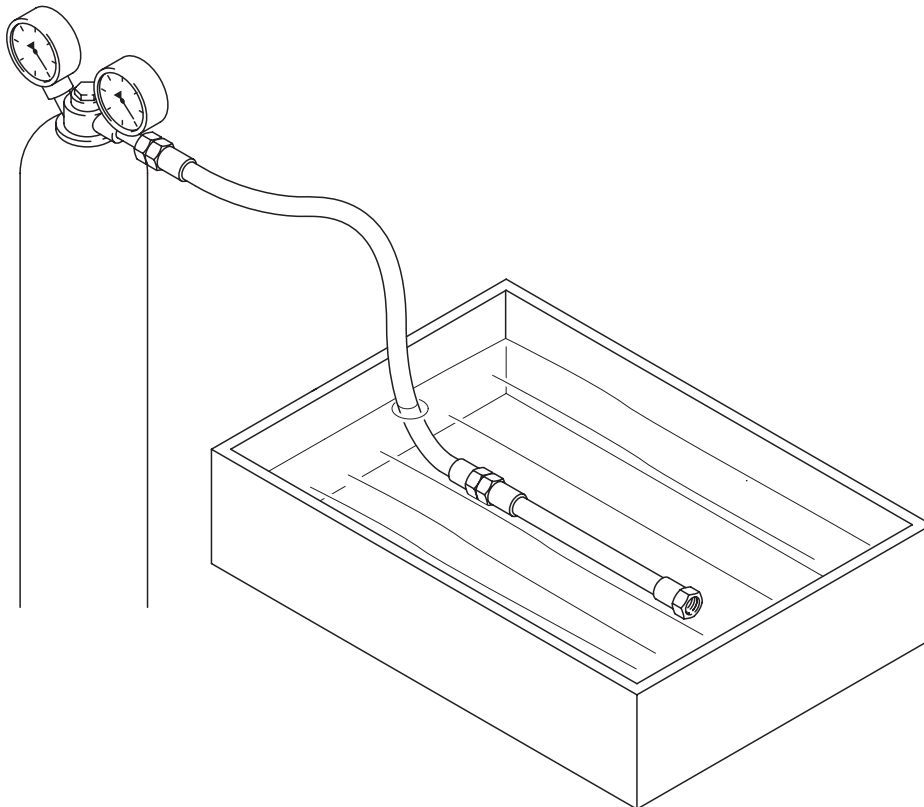

Fig. 405 Testing hoses for leaks

4.10 Install the roof-top unit with air ducting system or air distribution panel

4.10.1 Air duct sealing

A weatherseal is to be produced using the supplied sealing strips (see Fig. 407) for curved roofs or roofs with beads and channels.

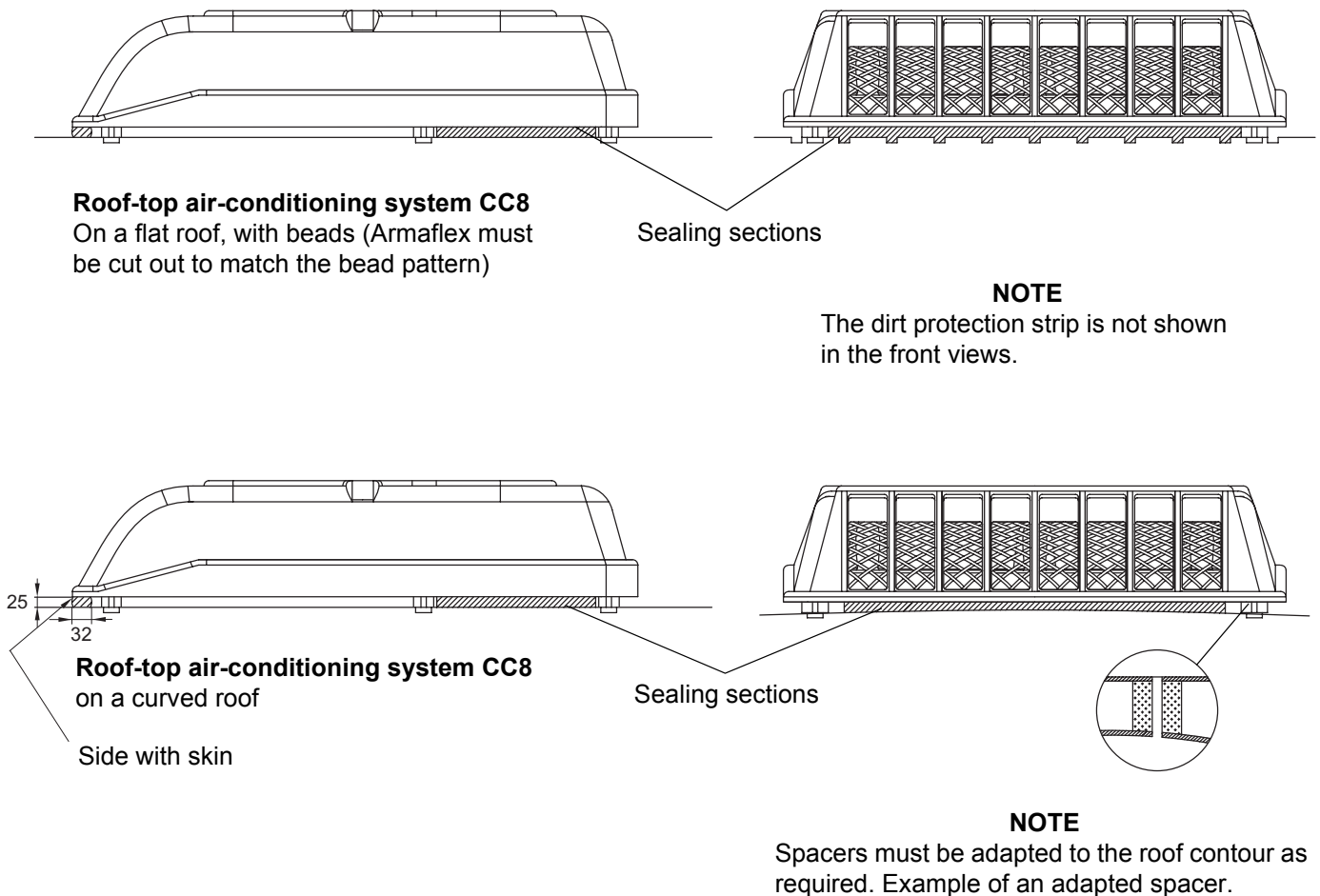

Fig. 406 Roof seal

The Armaflex/Eurobatex strip (32 x 25 x 850 mm) protecting the system against dirt must be bonded to the transverse base frame profile of the roof-top unit with Sikaflex (supplied in the installation kit) so that the side with skin faces outwards.

On flat roofs or roofs without beads and gutters a seal made with Sikaflex is sufficient instead of a weatherseal.

4.10.2 Preparing the weatherseal

1. Cut out the weatherseal taking care to adapt its thickness to the contours of the roof (beads, channels and roof curvature), so that the contours (Fig. 406) are properly sealed.
The thickness of the sealing material should be compressed by approx. 20 %-40 % when the air-conditioning unit is installed.
2. The height of the spacers may have to be adjusted so that the sealing strip is pressed on to the roof over its entire length.

NOTE

The roof must be dry and clean for bonding.

3. Cut the sealing strips to length and glue them together with Sikaflex (supplied in the installation kit) at the points of contact to form the weatherseal.
4. Affix the weatherseal to the underside of roof-top unit as shown in Fig. 407 using Sikaflex 221 and leave to cure for approx. 2 hours.
5. Apply Sikaflex sealing compound to the underside of weatherseal before fitting base frame on the top of roof.

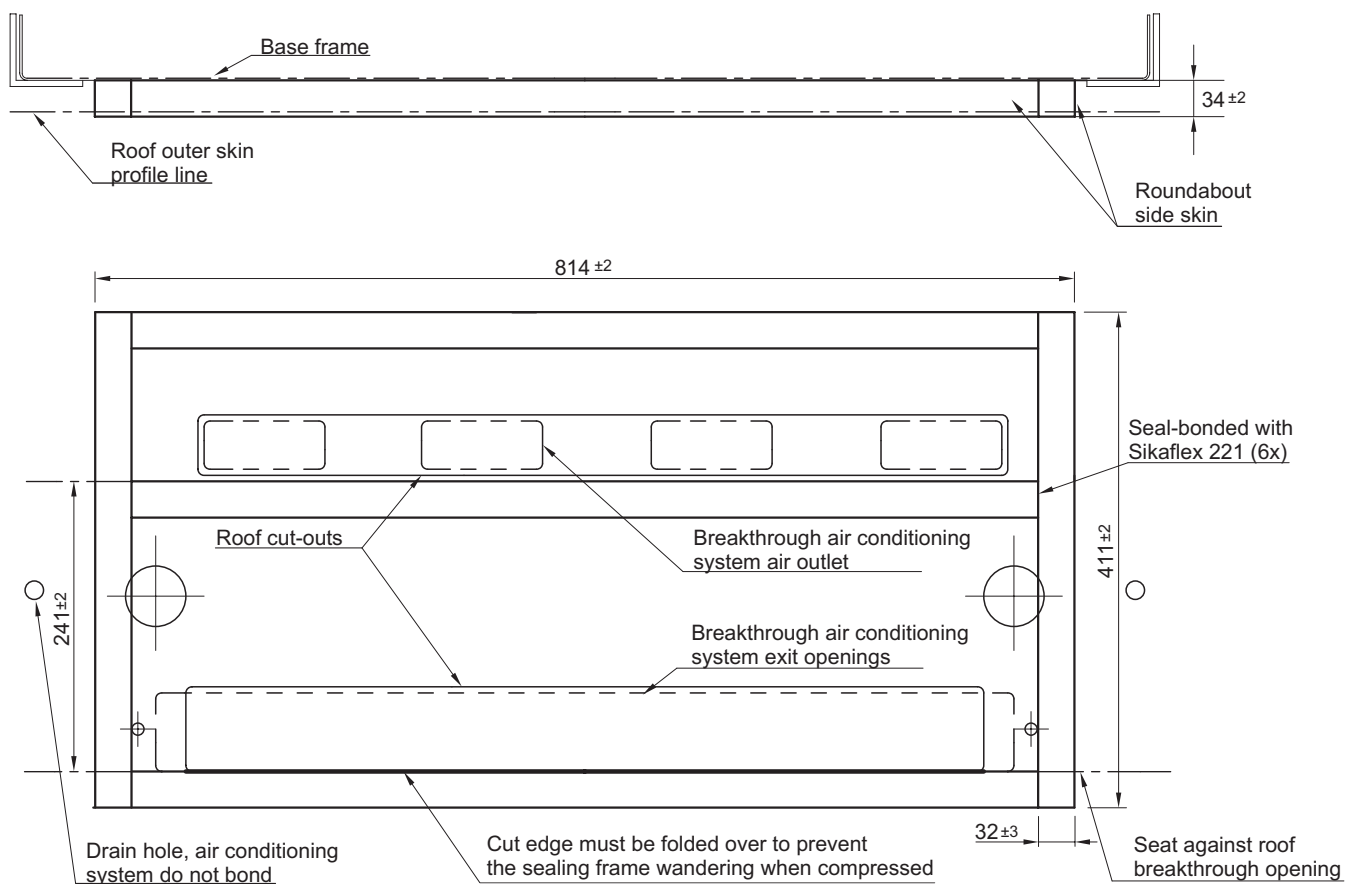

Fig. 407 Weatherseal made from Armaflex/Eurobatex sealing sections

NOTE

If Sikaflex 221 is used to install the roof-top unit, it must be allowed to cure for 3 – 5 hours. Install the base plate before Sikaflex has cured. Do not expose the seal to moisture until the Sikaflex has cured.

4.10.3 Install the base frame

1. Remove the cover from the air-conditioning unit.
2. Position the base plate on the roof with the weatherseal, align it and position spacer discs underneath the six fixing points. Place six M8 bolts with washers in the holes (see Fig. 408).

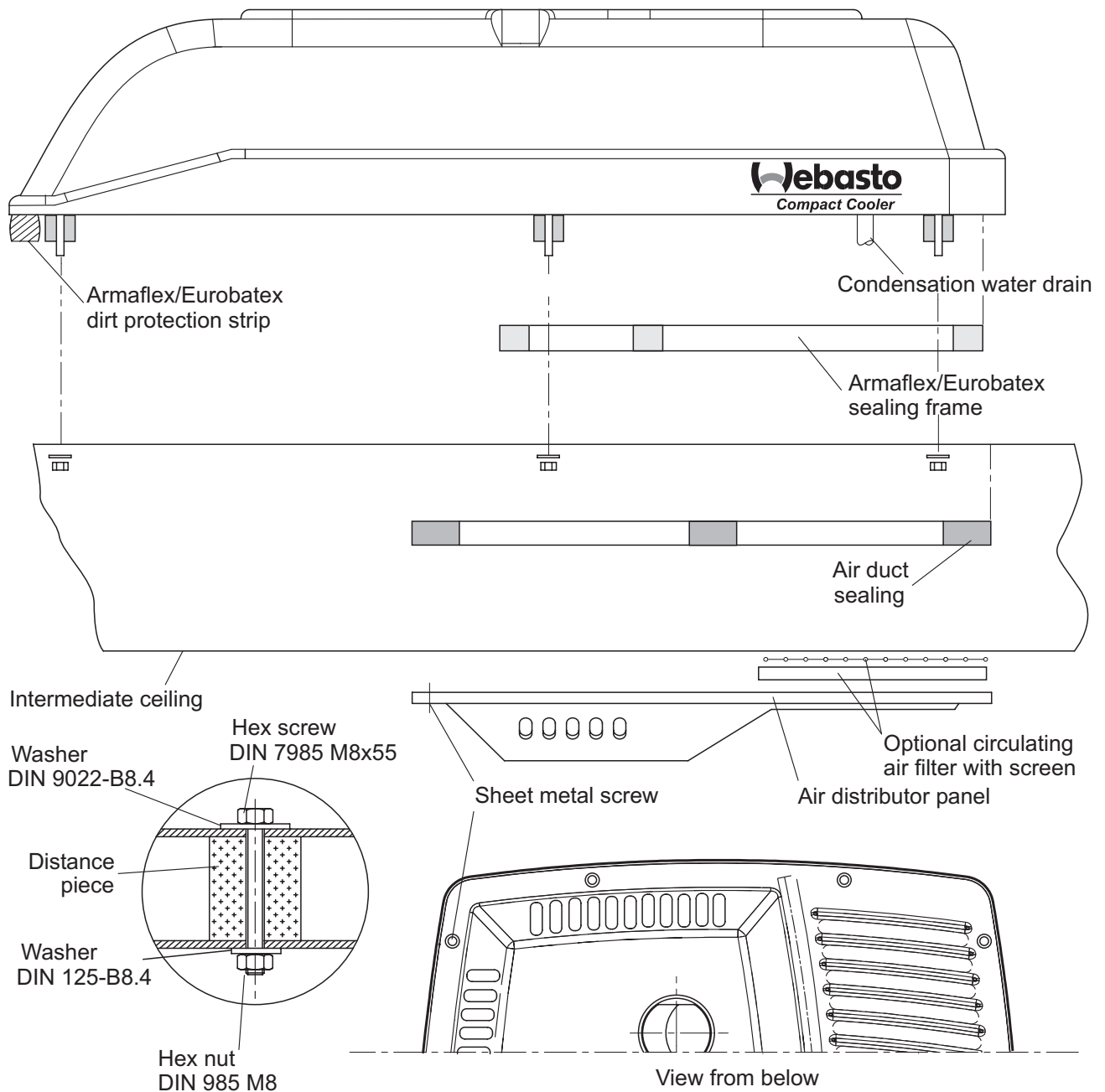

Fig. 408 Installation of the base plate

3. Check that the base plate is in the correct position and secure it uniformly using the washers, and nuts supplied in the installation kit (tightening torque 15 Nm).
4. The tightening torque for the self-tapping screws must be such that it does not damage the air distribution panel and mounting points.
5. Route refrigerant hoses, electric cables and condensation hoses as shown in 4.12 and 4.13.

4.10.4 Assemble the air distribution panel

NOTE

Depending on the version and the components supplied, the rocker switches and, if applicable, the setpoint generator switch may have to be installed in the air distribution panel.

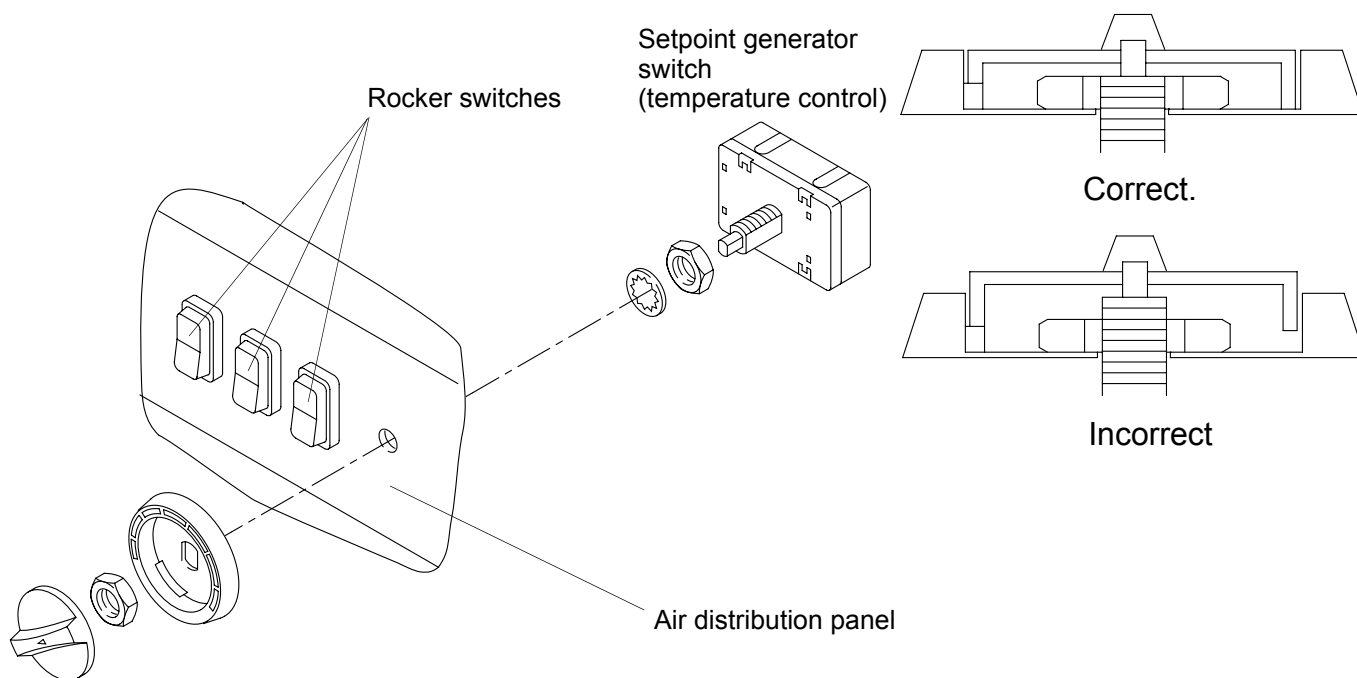

Fig. 409 Air distribution panel, assembly

1. Insert the rocker switches in the rectangular cut-outs in the air distribution panel so that they engage. (see Fig. 409).
2. Insert the setpoint generator switch into the hole in the air distribution panel as shown in Fig. 409.

NOTE

The wiring harness is (mechanically) prepared for connection to the setpoint generator potentiometer. Simply pull on connector housing to unplug the connector. The connector housing can be locked (self-locking action) by simply pulling on the wiring harness. The fibre optic cable must be in contact with the rotary knob.

4.10.5 Install the air distribution panel

1. Prepare the air duct weatherseal (if necessary) in such a way that it securely seals the intake and discharge sections between the vehicle roof and the intermediate ceiling at the top and all sides.
2. Prepare the air duct seal for the air distribution panel as shown in 4.7 and fasten it to the interior of the roof.

NOTE

When you secure the air duct seal, ensure that you do not damage the roof-top unit, which you have already installed and that the installation holes do not cause the roof to leak.

3. Make cut-outs for the air outlet and discharge openings in intermediate ceiling to match those in the roof and the air duct seal. The cut-outs must be as large as possible, but they must be covered by the air distribution panel.
4. Install the intermediate ceiling.
5. Make the cable connections between the air distribution panel and the base plate (see Figs. 701, 702 and 703).
6. Position the air distribution panel as shown in Fig. 408 and fasten it to the intermediate ceiling or to suitable mounting brackets provided by the customer with 10 self-tapping screws. If necessary, insert a grille for the circulating air filter and insert the circulating air filter in the intake area of the air distribution panel first.

4.10.6 Install the air ducting system

1. Prepare the air duct weatherseal (if necessary) in such a way that it securely seals the intake and discharge sections between the vehicle roof and the intermediate ceiling at the top and all sides.
2. Prepare the air duct seal for the air distribution panel as shown in 4.7 and fasten it to the interior of the roof.

CAUTION

When you secure the air duct seal, ensure that you do not damage the roof-top unit, which you have already installed and that the installation holes do not cause the roof to leak.

3. Make cut-outs for the air outlet and discharge openings in intermediate ceiling to match those in the roof and the air duct seal. The openings must be as large as possible, but they must be covered by the air distribution panel.
4. Install the intermediate ceiling.
5. Make the cable connections between the base plate and the dashboard (see Figs. 701, 702 and 703). The control elements wiring harness (optional) is required for this purpose.
6. Position the air distribution panel as shown in Fig. 408 and fasten it to the intermediate ceiling or to suitable mounting brackets provided by the customer with 9 self-tapping screws. If necessary, insert a grille for the circulating air filter and insert the circulating air filter in the intake area of the air distribution panel first.
7. Assemble the air ducting frame, comprising the frame end, frame segments and connectors (the number depends on the length of air duct) using Torx 30 oval-head bolts M6 x 16, washers DIN 9021-B6.4-ST-A36 and hexagonal nuts DIN 984-M6-6-A360 (tightening torque 5 Nm) as shown in Fig. 410.

NOTE

Ensure that the frame parts and surfaces are flush when they are screwed together. There must not be any difference in height at the frame end.

8. Measure the length of ducting parts and thus calculate the insertion depth of the air ducting frame in the air distribution panel.
9. Place air ducting frame in the centre of the vehicle roof and align it with the markings for insertion depth.

10. Secure the assembled air ducting frame through the intermediate ceiling to the vehicle roof bows with self-tapping screws and fan-disk washers. Fit shims between ducting frame and intermediate ceiling to compensate for any unevenness if necessary.
11. If necessary, secure at additional points with mounting brackets or plugs you make yourself.
12. Seal the existing cut-outs for lights in the intermediate ceiling.
13. Align the rear central air duct with air ducting frame and air distribution panel. Mark the mounting holes on air ducting frame and connectors.
14. Drill the mounting holes with a diameter of 7.0 mm in air ducting frame, panel transition elements and frame connectors. (The predrilled holes in the central and end air ducts can be used as a template.)

NOTE

Before drilling holes, ensure that the gap between the individual ducting elements is as small as possible and that the connector is located in the centre of the air ducting frame.

15. Affix strips of expanded rubber under the ducting frame / connecting elements to prevent vibration (see Fig. 410).
16. Secure the central air ducts to air ducting frame through the air distribution panel with plastic clips.
17. Fit additional central and end air ducts as described in steps 12 to 14.

NOTE

The air ducting system installation kit includes additional plastic expanding rivets which can also be used to secure the air ducting system in position if gaps form at the sides, for example due to stress in the air duct covers.

CAUTION

When installing the cab lights in the air ducting system, the openings in the air duct covers must be reinforced or reinforced extension kits (part No. 900 1161) and a reinforced end air duct (part No. 900 1288) with suitable interior lights (part No. 64055) must be used instead.

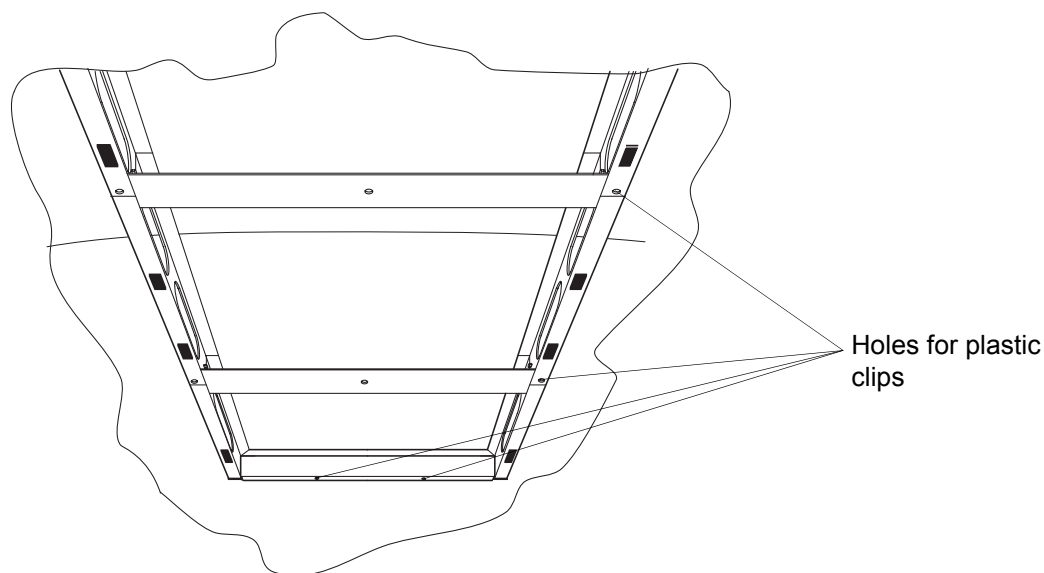

Fig. 410 Air ducting frame

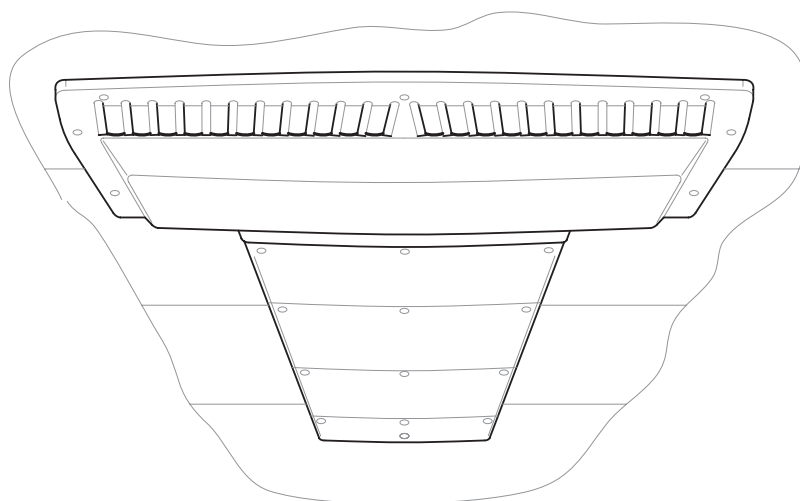

Fig. 411 Air ducting system

4.11 Install the compressor

Before you install the compressor in the vehicle, the factory-filling of lubricating oil for the compressor (see the technical data for the compressor) must be made up to the proper quantity. The amount of oil required depends on the length of hose used and is shown in the following table.

	Hose length	Oil quantity	Additional oil *
Air-conditioning system	6 m	240 cm ³	+ 60 cm ³ **
	11 m	270 cm ³	+ 90 cm ³ **
	16 m	300 cm ³	+ 120 cm ³ **

*
 ** Tolerance + 30 cm³

Oil must be topped up via the oil filler plug on the compressor or via the high pressure port.

The final amount of refrigerant depends on the installation and must be determined using the inspection window as described in the installation instructions.

Please note that the compressors are prefilled with refrigerator oil by the manufacturer. The prefilled amount of refrigerator oil can be found in the compressor drawing and is specified on the compressor label.

NOTE

Refrigerator oil is highly hygroscopic and must therefore be exposed to air for as short a time as possible. The compressor and oil tank must therefore be resealed as quickly as possible.

1. Mount the compressor on the engine (see 4.8) (see installation position in Fig. 402).
2. Fit the V-belt and tension it.
3. Check the installation position.

WARNING

Keep hands, long hair and other objects well clear of all rotating parts.

4. Start the engine and check that the V-belt pulley runs smoothly and correctly.

4.12 Make the electrical connections

NOTE

Plug connections can be protected against moisture with a suitable wax.

1. Disconnect the vehicle battery.

CAUTION

- Follow the vehicle manufacturer's instructions for connecting the power supply for the air-conditioning system.
 - Only use cables approved for use in motor vehicles with an adequate cross-section (see Figs. 701, 702 and 703).
 - Work on the electrical system may only be carried out by authorised personnel.
 - Use rubber grommets for routing cables through sheet metal cut-outs.
2. Route and connect the cables as shown in Figs 701, 702 and 703.
 - Whenever possible, place cables in protective sheaths and secure them properly with cable ties.
 - Thread the positive and negative leads for the power supply of the air-conditioning system and the cable for the compressor connection through the cable grommet in the system.
 - Use strain-relief clamps.

NOTE

If the controls are not to be installed in the air distribution panel, a wiring harness for the external installation of the controls is available from Webasto to extend the electrical wiring to the **controls** in the dashboard.

4.13 Prepare and install the refrigerant lines and condensation hoses in the vehicle

CAUTION

- The line openings must remain capped until immediately before their connection.
- Follow the vehicle manufacturer's instructions for their installation.

1. Prepare both refrigerant hoses as described in 4.9.
2. Route the refrigerant hoses from the connection on the roof-top air-conditioning unit to the compressor and connect them. Observe the following as you do so:
 - Wet the O-rings with refrigerator oil before fitting them.
 - Route the hoses with no tension and not on sharp edges and secure them with clamps and cable ties for strain relief. Do not bend the hoses through angles below their minimum bending radii. See 4.9 for minimum bending radii.
 - Fit rubber grommets or edge protectors to cut-outs and seal them if necessary with sealing compound, for example Sikaflex 221.
 - To reduce the formation of condensation, wrap the screw connection on the expansion valve in the insulation tape supplied in the installation kit.
 - We advise you to insulate the intake line inside the cab in order to prevent formation of condensation. Ensure that hoses are routed in such a way that they cannot rattle.
3. Secure the condensation hose to the condensation drain as shown in Fig. 412 and route it downwards along the refrigerant hoses. Route the hose out of the vehicle at a suitable point, but not near the silencer. Do not exceed the bending radius $R = 85$ mm.

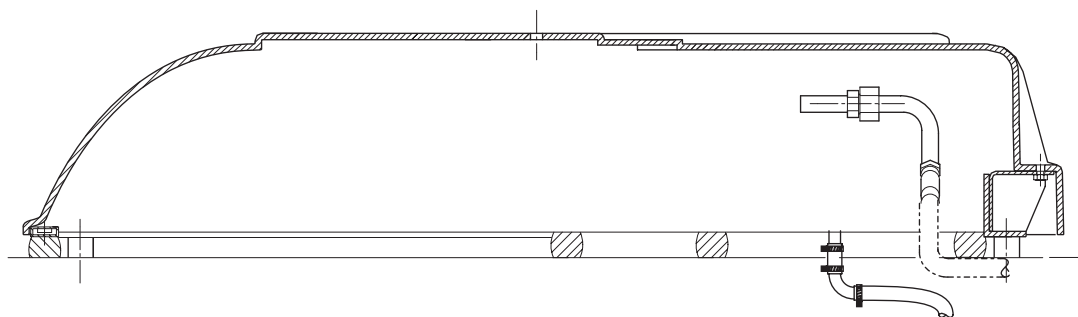

Detail, condensation water connection

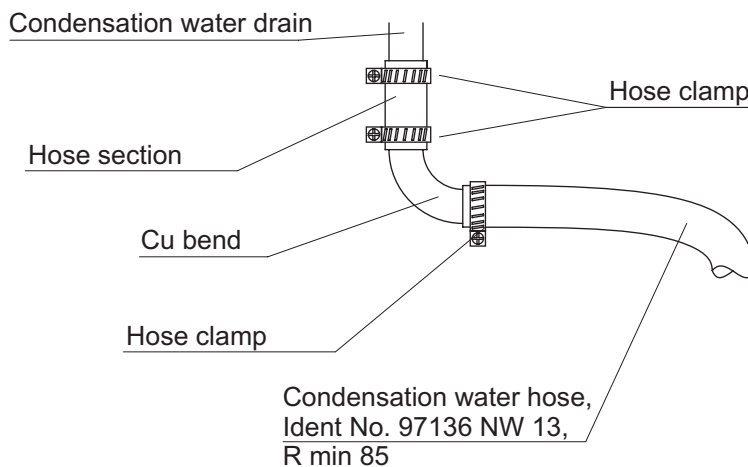

Fig. 412 Condensation hose connections

4.14 System leak-testing and evacuation

4.14.1 General

- Moisture and air or other gaseous impurities in the refrigerant circuit cause malfunctions and may damage the air-conditioning system components. The system therefore must be thoroughly dried and evacuated (for at least 1.5 hours) before it is filled with refrigerant. This not only applies to newly installed air-conditioning systems, but also to systems that have been repaired if the refrigerant had to be discharged beforehand.

The final vacuum in the system must not exceed the absolute vacuum by more than 0.005 bar. Consequently the absolute pressure in the system must be ≤ 0.005 bar.

- The absolute pressure indicated on the gauge depends on the ambient atmospheric air pressure. This must be taken into consideration.
- Refrigerant can escape through the smallest leaks. The refrigeration circuit must therefore be completely sealed. To prevent any unnecessary refrigerant loss from occurring, we recommend that the system be inspected repeatedly for leaks during the evacuation process.
- The quick-action stop valves are fixed to the fittings on the refrigerant hoses. The quick-action stop valves for the discharge and intake lines have different diameters so that the connections cannot be confused.
- An ambient temperature of at least 20°C is required for evacuating and filling the system.

4.14.2 Description of the fittings

The test fittings consist of a intake pressure gauge, a high pressure gauge and a vacuum pressure gauge, as well as the four ports listed below, all of which can be shut off by means of a stop valve.

Connections/hoses:

- LOW Connection for the intake side of the system
 - Yellow hose with Low Side quick-action stop valve
- HIGH Connection for the discharge side of system
 - Red hose with High Side quick-action stop valve
- REF Connection for the refrigerant bottles
 - Yellow hose with quick-release screw coupling 7/16" UNF
- VAC Connection for the vacuum pump
 - Yellow hose (thick) with quick-release screw coupling 5/8"

4.14.3 Evacuation

- Switch on the vacuum pump and evacuate the system for at least 1.5 hours. The absolute pressure achieved must be at least 0.005 bar.
- During the evacuation process with the pump running, repeatedly close all valves of the test equipment and check the pressure gauge readings. If there is no change in the vacuum reading over a period of one minute, you may assume that there are no leaks in the system. Re-open the valves after each pressure check.

NOTE

A rise in the pressure indicates a leak in the system. In this case, stop the evacuation process and isolate and seal the leak. Then repeat the evacuation procedure.

- Close all valves on the test equipment. Switch off the vacuum pump. Leave the system for at least one hour and then check the vacuum. If vacuum does not change, the system has been evacuated sufficiently and is not leaking.

4.15 Fill the system with refrigerant

4.15.1 General

NOTE

The ambient temperature should be at least 20°C during the filling process.

The air-conditioning system must be filled with the correct amount of refrigerant for it. Therefore it is important to weigh the refrigerant bottle before starting the filling procedure and to check its weight continuously. The quantity of refrigerant depends on the length of the hoses (see table below).

	Hose lengths	Recommended quantity of R134a refrigerant
CC8 air-conditioning system	6 m	approx. 2.0 kg
	11 m	approx. 2.1 kg
	16 m	approx. 2.2 kg

The proper amount of refrigerant must also be checked by watching the inspection window (the refrigerant must contain no bubbles), as it may vary, depending on the installation. The system will malfunction if it contains too much or too little refrigerant.

4.15.2 Pre-filling

NOTE

The pre-filling process is performed on the intake and discharge sides of the system.

CAUTION

The shut-off valve of the vacuum meter on the VAC test equipment must be closed since it would otherwise be destroyed.

1. Open the LOW, HIGH and REF shut-off valves.
2. Open the valve on the refrigerant bottle.
3. Allow refrigerant to flow into the system until the pressure in the bottle and that in the system have been equalised and the gauge readings no longer indicate any rise in pressure, or until the correct volume of refrigerant has been inserted. The resultant pressure depends on the refrigerant temperature.
4. Close all the valves on the test equipment and the bottle.

4.15.3 Leakage test

Use the leak detector to check all the potential sources of leaks in the system. Apart from the line connections, these include the refrigerant hoses themselves as well as the sealing surfaces on the compressor.

NOTE

Provided no leak is detected, the system can now be filled completely.

4.15.4 Final filling**CAUTION**

If liquid refrigerant is topped up on the intake side (bottle upside down), the compressor will be destroyed by the hammering action of the liquid.

NOTE

The air-conditioning system can only be filled completely when the compressor is running. To prevent the compressor being damaged, the refrigerant may only be filled in gaseous form through the intake side of the system. The bottle must always be kept in a vertical position with the valve at the top.

The higher the compressor speed, the shorter the time required for filling.

1. Fit cover on the roof-top air-conditioning unit.
2. Open the valve at the intake pressure gauge on the LOW test equipment. The high pressure valve remains closed.
3. Open the bottle valve and the REF filling valve.
4. Reconnect the vehicle battery and start the engine.
5. Set the air-conditioning system to cooling mode (fan speed 3) (see 5.3).
6. Check the weight of the refrigerant bottle and check the inspection window.

NOTE

The correct volume of refrigerant has been inserted into the system as soon as the refrigerant flows through the inspection with no bubbles with the engine at its high idling speed.

7. Close all valves on the test equipment. Switch off the air-conditioning system. Close the bottle valve, unscrew the compressor shut-off valves completely.
8. Switch off the engine.

4.16 Completion

1. Check the refrigerant pressures and the function of the pressure cut-out switches as described in 6.8.
2. Close all open covers on the vehicle/cab.
3. Have a qualified expert check that the installation work has been carried out properly.

5 Operating information

5.1 Safety precautions

Observe safety regulations contained in 1.4.

5.2 System control

CAUTION

- The air-conditioning system may only be operated with the engine running to prevent the battery from discharging.
- A distinction must be made between two cases to prevent leaks at the shaft seal of the compressor:
 - The compressor must not be switched on if the vehicle itself is not operated for a longer period of time.
 - If the vehicle is to be operated over a longer period of time without using the air-conditioning system, it is advisable to operate the compressor once every 14 days, otherwise the shaft seal of the compressor may be damaged.
- **Systems with fresh air ventilation flap (option)**
 - The fresh air ventilation flap should remain closed in winter.
 - The flap must be closed when the air-conditioning system is exposed to a direct water jet when cleaning the vehicle or when running the vehicle through a car wash.

NOTE

- In compliance with the electrical connection, system control and operation should only be possible with the engine running.
- If the air-conditioning system is connected so that fan operation is possible with the engine off, there will be no cooling effect. Operation with the engine off merely circulates the air inside the cabin.
Note that this will discharge the battery.
- The air-conditioning system is only serviceable when filled with the required amount of refrigerant and refrigerator oil as specified in the service and installation instructions.
Make sure to use refrigerant type R134a only.

5.3 Controls and indicators

Two rocker switches (Fig. 501) are used to control the roof-top air-conditioning system. As an option a temperature controller (command value switch) or a rocker switch for the fresh air ventilation flap may be installed.

- Air conditioning ON / OFF (2-position switch)
- 3-position rocker switch (fan power)
- Rocker switch (fresh air ventilation flap) (2-position switch) with illuminated indicator when open
- Command value switch (temperature controller)

The controls and indicators are preferably mounted in the air distribution panel or in the dashboard.

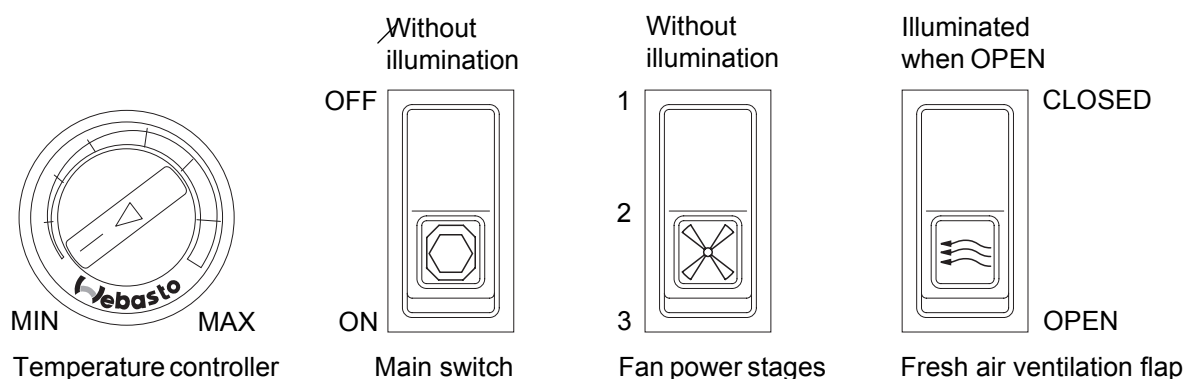

Fig. 501 Controls

5.4 First-time operation

1. Start the engine as directed by the manufacturer.
2. Switch on the system using the ON / OFF switch. Turn the temperature controller fully clockwise to the right. Run the system at maximum fan power (3-position rocker switch in position 3). After 2 minutes at the latest, cold air must stream from the air distribution panel or the air duct.
3. Reduce fan power to other stages and check air stream.
4. **Systems with fresh air ventilation flap (optional):**
Open the flap via the rocker switch. After a few seconds, the flap reaches the max. open position and the indicator lights up.
5. **Systems with electronic room thermostat (optional):**
Turn the command value switch (temperature controller) fully counter-clockwise to the left. The compressor is switched off as soon as the air intake temperature is below 30 °C.

5.5 Operating instructions

NOTE

Observe operator's instructions.

Before starting operation, ensure that:

- the air-conditioning system is in perfect working order;
- scheduled maintenance / checks have been performed;
- air inlets and outlets are unobstructed (no leaves, etc.);
- condensation water drain holes are unobstructed.

Operation with engine running:

- The system is controlled by means of the rocker switches ON / OFF and the fan switch.
- With the engine running, the cabin interior cools in circulating-air mode according to the fan power stage 1, 2 or 3 selected.
- Without electronic room thermostat (temperature controller), the temperature of the air-conditioning system is controlled by the anti-icing thermostat integrated in the system. It switches off the compressor when the evaporator icing temperature is reached while the evaporator and condenser fans continue to run. The compressor is re-activated when the switching temperature of the anti-icing thermostat is exceeded.
- The cooling performance can be controlled manually via the fan power stage.

Stage 1: low cooling performance at low air outlet temperature and low fan power

Stage 2: medium cooling performance at medium air outlet temperature and medium fan power

Stage 3: high cooling performance at somewhat higher air outlet temperature and maximum fan power

NOTE

For quick cooling and dehumidification of the cabin interior with high outside temperatures and the sun shining, it is recommended to operate the fan at power stage 3 first. When a comfortable cabin temperature has been reached, the fan can be turned down to stage 2 or 1 depending on the outside temperature.

If the vehicle has heated up extremely by exposure to sunlight, the doors and windows should be opened first to ventilate the vehicle before switching the air-conditioning on.

5.6 Operation of air-conditioning system (with room thermostat function and fresh air ventilation flap)

Operation is as described in 5.5 for the basic version.

The required temperature can additionally be controlled by means of a rotary temperature controller. The compressor is switched off when the preset temperature is reached. It is reactivated by a rise in temperature of about 2K.

If the system has a fresh air ventilation flap, the flap can be opened and closed by means of the 2-position rocker switch. In the open position, the system operates in fresh-air mode and the indicator in the switch lights up.

6 Maintenance

6.1 Safety precautions

Observe safety regulations set out in 1.4.

6.2 General

1. Work on the refrigerant circuit may only be performed by skilled personnel and authorized workshops.
2. The specific equipment, special tools and accessories detailed in 4.3 are required and must be used for servicing the air-conditioning circuit.
3. Like all parts of the vehicle, the air-conditioning system is also subject to continuous stress. Scheduled maintenance must be performed regularly in order to ensure proper operation of the system and avoid damage.
4. Proper handling of the system and a complete record of all the required scheduled maintenance are essential for acceptance of possible warranty claims concerning damaged components subject to maintenance.
5. To prevent the shaft seals of the compressor drying out and to avoid moving components seizing up within the refrigerant circuit due to gumming, the air-conditioning system must be operated at least once a month for approx. 15 minutes when not in use. Requirement: minimum outside temperature > 5 °C or heated hall.

NOTE

Ensure that the amount of oil in the air-conditioning system is always at the level specified in the installation and service manual.

Total oil quantity = oil quantity for compressor (see 3.3) + oil quantity according to hose length (see 4.10).

CAUTION

- The flap must be closed when the air-conditioning system is exposed to a direct water jet when cleaning the vehicle or when running the vehicle through a car wash.
- The fresh air ventilation flap should remain closed in winter.

6.3 Maintenance and care

1. Regardless of the following maintenance schedule, all component attachments and the refrigerant hose connections must be checked to ensure they are secure after the first 4 weeks of operation of the roof-top air-conditioning system.
2. Even if the air-conditioning system is not operated, individual components are subject to wear due to normal ageing or stress due to vehicle operation. All checks listed in the maintenance and servicing plan must therefore be performed regardless of the system operating hours.
3. Even if hose connections do not leak, refrigerant may be lost regardless of operating hours. Due to the material structure of refrigerant hoses, they have a diffusion rate that varies with ambient temperature. However, considerable loss of refrigerant in a short period of time indicates that there is a leak in the system.
4. Slight contamination of evaporator and condenser fins is removed with compressed air applied against normal direction of air flow.

Major contamination or greasy deposits must first be removed with soapy water or a suitable cleaning solvent (not aggressive for copper or aluminum) before cleaning with compressed air or a water jet.

CAUTION

A jet of air or water must never be aimed directly towards the fins, otherwise they may be damaged!

5. The receiver-drier must be replaced at least once a year and whenever work is performed on the refrigerant circuit.

CAUTION

Refrigerant must never be discharged into the atmosphere (refer to Section 8 of the regulation dated 6 May 1991 banning the use of CFCs and halones).

6.4 Maintenance and service checklist

System component	Maintenance task	Frequency		
		m	6m	a
Refrigerant circuit				
– Hoses	Check for chafing and general condition		X	
– Connections	Test for leaks with leak tester			X
– Refrigerant quantity	Check refrigerant level in viewglass	X		
– Condenser	Check condition (clean if contaminated)		X	
– Receiver-drier	Replace			X
– Condensation water drain	Check free passage and clean as required		X	
– Roof-top unit	Check overall condition and secure attachment of connections			X
Compressor				
– Magnetic clutch	Check engagement without slip / compressor start-up		X	
– Compressor	Check noiseless operation		X	
– V-belt	Check serviceability and tension			X
– Mounting bracket	Check condition and secure attachment			X
Electrical connections				
– Wiring	Check undamaged condition		X	
– Connections	Check undamaged condition and secure attachment		X	

Abbreviations: m – monthly, a – yearly (a – every six months if operated throughout the year)

6.5 Inspections before repair

In order to avoid unnecessary disassembly or duplication of work, the overall condition of the air-conditioning system must be checked before starting any repairs.

Visual inspection

- Outer condition of roof-top unit:
 - Hood without cracks and no damage to paint finish
 - Air inlets and outlets clean and undamaged
 - Attachment points secure and without corrosion
 - Hose and wiring connections serviceable
 - Openings in metal undamaged.

2. Condition of hoses:
 - No cuts, squeezing, blisters, chafing
 - Clamps and quick-release couplings undamaged
 - Openings in metal undamaged.
3. Condition of air distribution panel or air ducting system:
 - Attachment points / screws secure
 - Ventilation switches serviceable
 - Circulating air filter clean.
4. Condition of compressor:
 - Hose connections undamaged and secure
 - Attachment parts / screws secure.

V-belt tension o.k.

V-belt and V-belt pulley undamaged

Magnetic clutch and electrical connection undamaged.

6.6 Troubleshooting

6.6.1 General

1. A systematic approach is advisable for troubleshooting. Appropriate action must be undertaken as described below for faults of a general nature or when normal conditions are not obtained during the pressure test.
2. Certain faults can only be located and remedied by skilled personnel using special tools.
3. If the compressor is damaged (e.g. defective valve plates) it is absolutely essential to replace the expansion valve as a possible cause of the malfunction.

6.6.2 Electrical system

The individual circuits must be systematically checked to isolate the fault with the aid of the applicable circuit diagram. Above all plug connections, switches, relays, etc., should be checked for continuity.

The following possibilities must always be checked and excluded as a possible cause of the malfunction:

- Defective fuses
- Corrosion on connector contacts
- Loose contact on connector
- Wrong crimping on connector
- Corrosion on wiring and fuses
- Corrosion on battery terminals

6.6.3 Air-conditioning system

- Defective evaporator or condenser fan
- Contaminated or clogged air filters, evaporator or condenser fins
- Loss of refrigerant or refrigerant level in system too low

If the system is deactivated continuously, we recommend that it be checked by an authorized workshop.

6.6.4 Refrigerant circuit

If faults develop in the refrigerant circuit, the system must be checked and properly repaired by an authorized repair shop. Under no circumstances may refrigerant be discharged into the atmosphere (refer to Section 8 of the regulation dated 6 May 1991 banning the use of CFCs and halones).

6.6.5 Pressure testing

If normal conditions are not obtained in pressure tests (see 6.8), this may be due to the following causes. These causes must be checked, the trouble located and defective components repaired or replaced.

High pressure gauge indication too high:

- Condenser air flow restricted
- Too much refrigerant
- Filter drier clogged

High pressure gauge indication too low:

- Not enough refrigerant (check viewglass)
- Compressor speed too low (e.g. by slippage of V-belt)
- Compressor defective

Low pressure gauge indication too high:

- Expansion valve defective
- Compressor speed too low (e.g. by slippage of V-belt)
- Compressor defective

Low pressure gauge indication too low:

- Intake or delivery line restricted, e.g. by kinks
- Expansion valve defective
- Not enough refrigerant (check viewglass)
- Evaporator air flow restricted

6.7 Repairs**CAUTION**

Refrigerant must never be discharged into the atmosphere (refer to Section 8 of the regulation dated 6 May 1991 banning the use of CFCs and halones).

NOTE

The safety precautions and regulations contained in chapter 1.4 and 6.2 must be observed.

For repairs always use original spare parts and restore original system condition, otherwise warranty will be lost.

1. The system's original condition must always be restored when performing repairs.
2. Before opening / disassembling components in the refrigerant circuit, the refrigerant must be drained into the recycling cylinder provided and disposed of properly or reused.
3. After completing repairs on the refrigerant circuit, the system must be
 - evacuated as described in 4.14
 - filled with refrigerant in accordance with 4.15
 - tested in accordance with 6.8.

6.8 Post-repair procedures and testing

6.8.1 Check refrigerant pressures and pressure switches function tests

1. General

Every air-conditioning system filled with refrigerant is in a state of overpressure, which is equal throughout the system circuit and which depends on ambient temperature.

During operation of the system, the working pressure on the intake side differs from that on the delivery side of the compressor. The pressures differ and are influenced by the compressor operating speed, the temperature inside the vehicle, the outside air temperature and relative humidity. Abnormal working pressures indicate that there is a fault in the system.

Working pressures should be checked at a compressor speed of approx. 3000 rpm and an air temperature between 20 °C and max. 35 °C. The fan must be operated at full power, stage 3. The hood must be fitted for pressure testing and for functional testing of the pressure switches, as the application of air to the heat exchangers has a decisive influence for obtaining the operating pressures.

The following operating pressures must be obtained with the **compressor in operation**:

Outside air temperature	Low pressure gauge	High pressure gauge
20 °C	2.0 bar abs \pm 0.2 bar	10 bar abs \pm 2 bar
25 °C	2.1 bar abs \pm 0.2 bar	12 bar abs \pm 2 bar
30 °C	2.3 bar abs \pm 0.2 bar	14 bar abs \pm 2 bar
35 °C	2.7 bar abs \pm 0.2 bar	16 bar abs \pm 2 bar

If different pressure values are obtained, an authorized repair shop must be consulted to investigate the reasons.

When the pressure test is complete, disconnect the pressure gauges and refit the sealing caps.

2. High pressure switch test:

- Connect pressure gauges to system.
- Remove fuse (F1 and F2) of condenser fan and fit hood.
- Run engine at medium engine speed and switch on air-conditioning system.
- Check whether compressor switches off at a pressure of 22.5 ± 2 bar.
- Remove hood and refit fuse of condenser fan.
- Check that compressor switches on again when pressure drops to 20 ± 2 bar.

3. Perform complementary steps.

CAUTION

If the high pressure switch is not working properly, switch off the air-conditioning system immediately, as refrigerant will be discharged via the pressure relief valve as soon as the pressure reaches 34.5 bar.

6.8.2 Replenishing partially filled systems with refrigerant

1. General information

Normally there is no consumption of refrigerant. A loss of refrigerant may only occur due to leaks after some time of operation.

The performance of the air-conditioning system will be reduced if the refrigerant level drops below the minimum level. Extreme loss of refrigerant results in deactivation of the low pressure switch.

A viewglass is integrated into the circuit at the receiver-drier to check the refrigerant level. Bubble-free refrigerant will flow through the viewglass approx. 5 minutes after switching on the properly filled air-conditioning system with the engine idling at slightly elevated speed. Occasional bubbles are meaningless. Replenishment is only necessary when foam builds up.

Refrigerant is normally replenished with the refrigerant in the gaseous state. When completely drained, the circuit must be properly evacuated before refilling with refrigerant.

The hood must be fitted for replenishment, as the application of air to the heat exchangers has a decisive influence for obtaining the normal operating condition of the refrigerant circuit.

2. Replenishment of refrigerant

Gaseous refrigerant may only be replenished with the compressor running and only via the system intake side.

For gaseous replenishment of the system, the refrigerant cylinder must be upright with the valve on top. Refrigerant is filled via the pressure test gauges set up in accordance with 4.15.

6.9 Visual inspection

A visual inspection in accordance with 6.5 must be performed upon completion of the repair work.

7 Circuit diagrams

Wiring harness CC8 basic	W1	67191
Adapter harness	W2	97452
Wiring harness CC8 external controls	W5	67043
Connector terminal M6/M8	X	81992
Fuse box	FA	81676
Anti-icing thermostat	S4	65354
HP/LP switch	S3	66553
Rocker switch 1-2-3	S2	66595
Rocker switch ON-OFF	S1	66596
Radial fan	M1, M2	80865
Axial fan	M3, M4	90629
Relay	K1, K2, K4, K5, K7, K8	96560
Relay	K3, K6	96525
Flat fuse	F1 - F5	25A, 25A, 10A, 20A, 20A, 15A, 15A, 7.5A, 15A, 15A
Nomenclature	Item	12 V
		24 V

Wire colours	
bl	blue
br	brown
ge	grey
gr	green
gr	grey
or	orange
rl	red
sw	black
vi	violet
ws	white

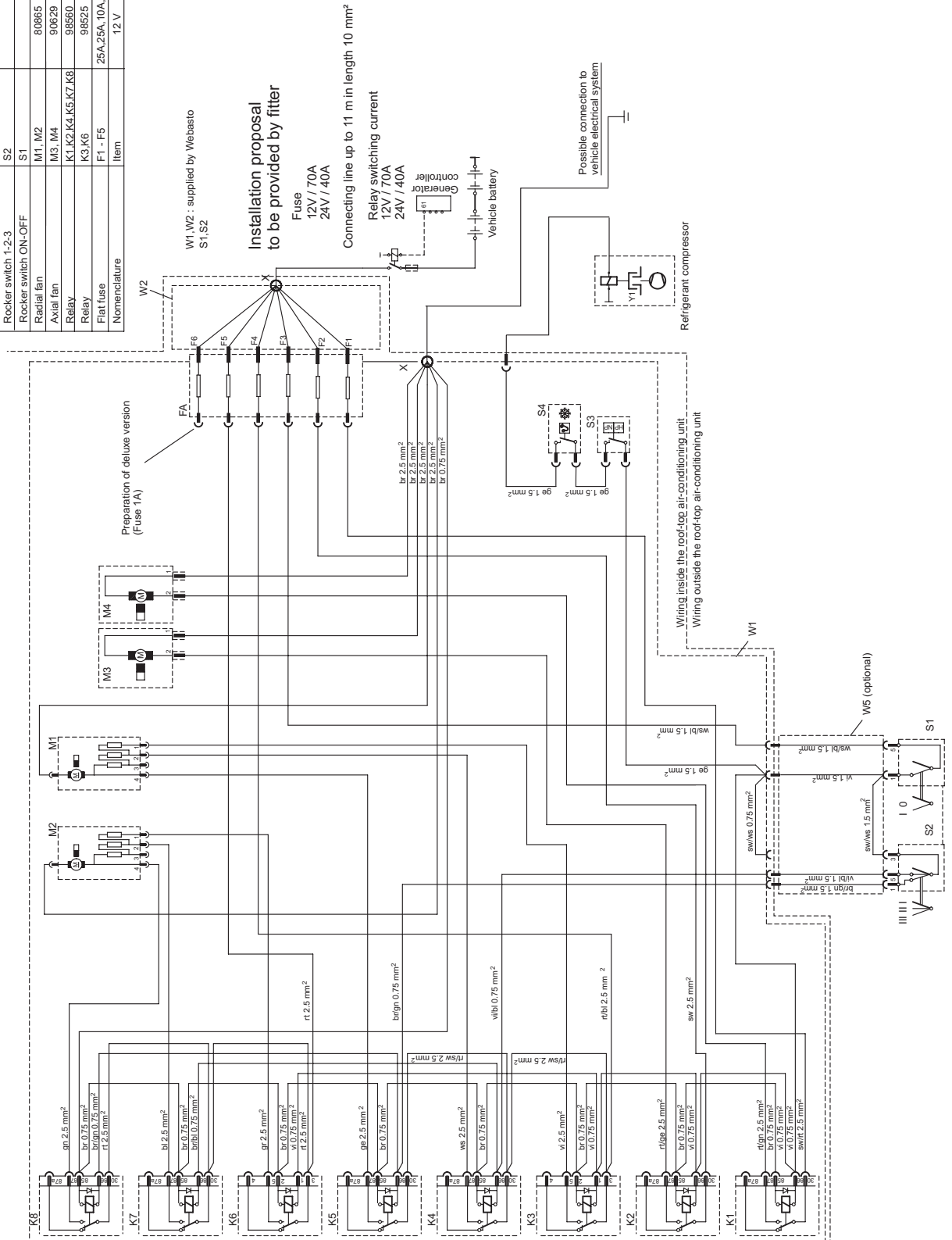

Fig. 701 Circuit diagram, basic version

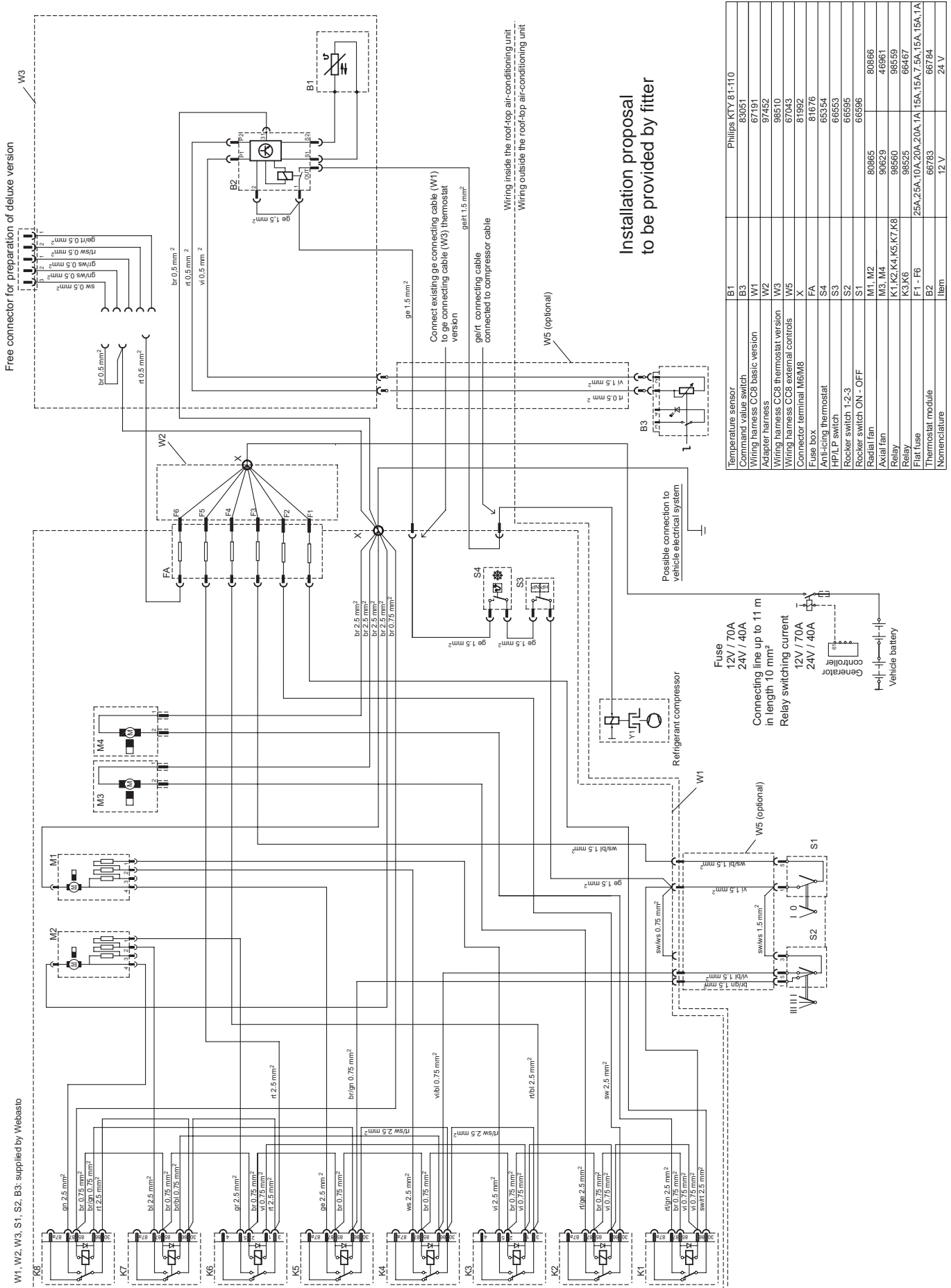

Fig. 702 Circuit diagram, thermostat version

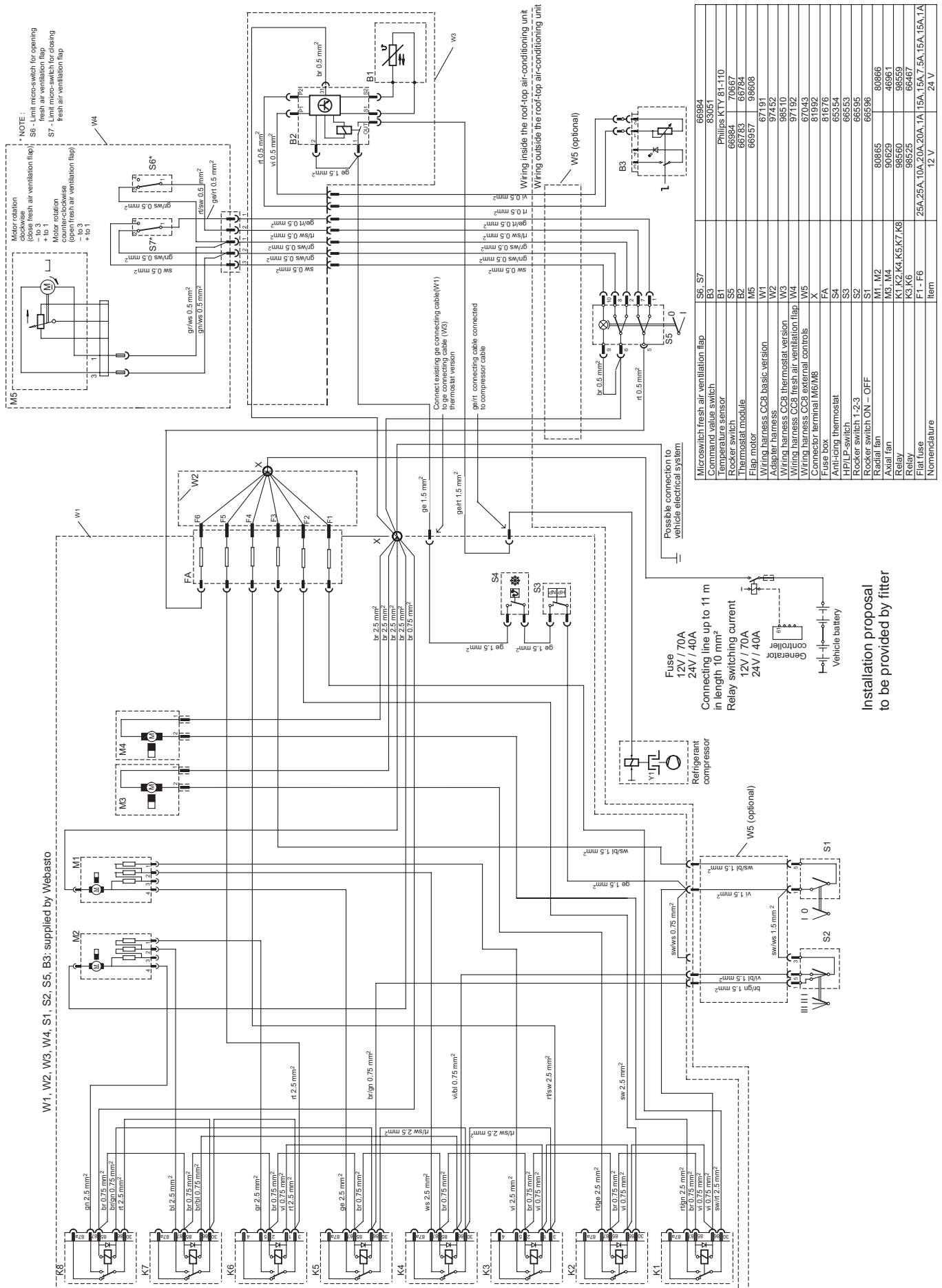

Fig. 703 Circuit diagram, fresh air and thermostat version

8 Tightening torques for some spare parts

Ident No.	Designation	Torque	
63960B	Hood ZSB, basic version	6 Nm (11x)	
98529B	Hood ZSB, deluxe version	6 Nm (11x)	
63956B	Exterior air screen, hood	5 Nm (1x) centre front	
98865A	Axial fan VA15-AP6-39S Volt: 12 V sealed	16 Nm (4x)	
98866A	Axial fan VA15-BP1-39S Volt: 24 V sealed	16 Nm (4x)	
98871B	Radial fan 008-A45-02; 12 V resistance box parallel	5 Nm (2x)	
98872B	Radial fan 008-B45-02; 24 V resistance box parallel	5 Nm (2x)	
9000492A	Binary pressure switch	14 Nm (1x)	
9000493A	Receiver-drier ZSB	17 Nm (2x)	
67024D	Refrigerant hose NW 8	ST 17 Nm, EV 5 Nm (1x each)	***
98510B	Wiring harness, thermostat version	5 Nm (1x)	*
92830E	Condenser	5 Nm (13x)	
80087A	Thermostat expansion valve TCDF 2	5 Nm (3x)	*
65354A	Thermostat (anti-icing protection)	Hand-tight	*
66975A	Flap motor 12 V ZSB	4 Nm (3x)	
98750A	Flap motor 24 V ZSB	4 Nm (3x)	
66280B	Air distribution panel ZSB	WARNING	**
98696B	Air distribution panel duct ZSB	WARNING	**
65612A	90° screw fitting with flange OR ZSB (NW 16)	5 Nm (1x) on EV	***
98512A	90° screw fitting OR ZSB (NW 12) (3/4")	36 Nm (1x)	
65356A	90° screw fitting OR ZSB with filler neck (NW 12) (3/4")	26 Nm (1x)	
65358A	90° screw fitting OR ZSB with filler neck (NW 16) (7/8")	35 Nm (1x)	
97638A	Straight screw fitting OR ZSB with filler neck (NW 12) (3/4")	26 Nm (1x)	
97639A	Straight screw fitting OR ZSB with filler neck (NW 16) (7/8")	35 Nm (1x)	

NOTE

- * Torque must be such that mount and piping are not damaged!
- ** Depending on the screwdriver used, the torque must be such that neither the air distribution panel nor its attachment is damaged!
- *** Expansion valve

9 Warranty claims

- Period of warranty 2 years (except compressor with warranty for 1 year).
- Components subject to normal wear (e.g. receiver-drier, air filter, refrigerant, etc.) and components which are not handled properly are excluded from warranty.
- The warranty period for the complete system is not extended by repairing defective components.
- When replacing components, warranty will of course start from the day of their installation.
- In the event of a claim, please contact your local agent and present the
 - claimed component,
 - warranty card and
 - warranty claim form.

