

Wiringkit

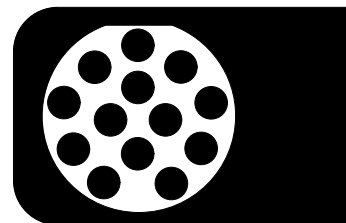

- D Einbauanleitung
- GB Installation instructions
- F Consignes de montage
- NL Montagehandleiding
- DK Montagevejledning
- N Monteringsinstruksjon
- S Installationsanvisning
- FIN Asennusohje
- I Istruzioni per il montaggio
- E Instrucciones de montaje
- P Instruções de montagem
- GR Οδηγίες εγκατάστασης
- CZ Návod k montáži
- SLO Navodilo za vgradnjo
- SK Montážny návod
- PL Instrukcja montażu
- TR Montaj talimatı
- H Beépítési útmutató
- HR Upute o ugradnji
- BUL Инструкция за монтаж
- RO Instrucțiuni de montaj
- RU Инструкция по монтажу и установке
- LT Montavimo informacija
- LV Iemontēšanas pamācība
- EST Paigaldusjuhend

701504

VW

- **Tiguan** 05/16 >>
- **T-Roc** 01/18 >>

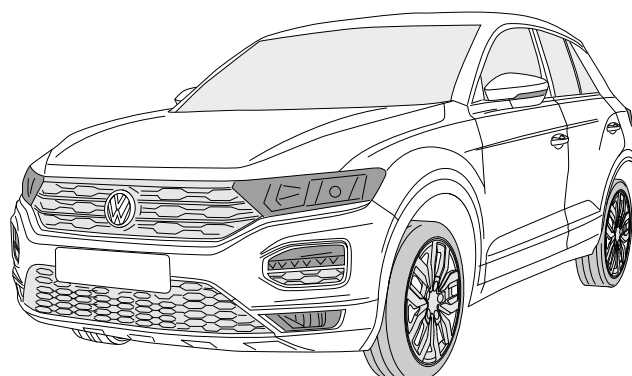
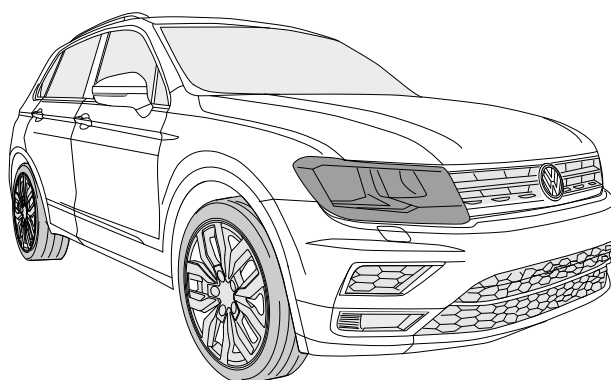

OVERVIEW

For vehicles with trailer preparation

OPTION 1

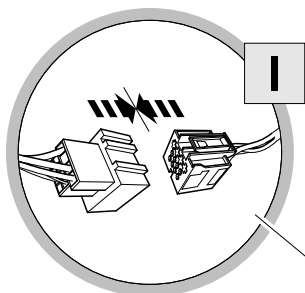

OPTION 2

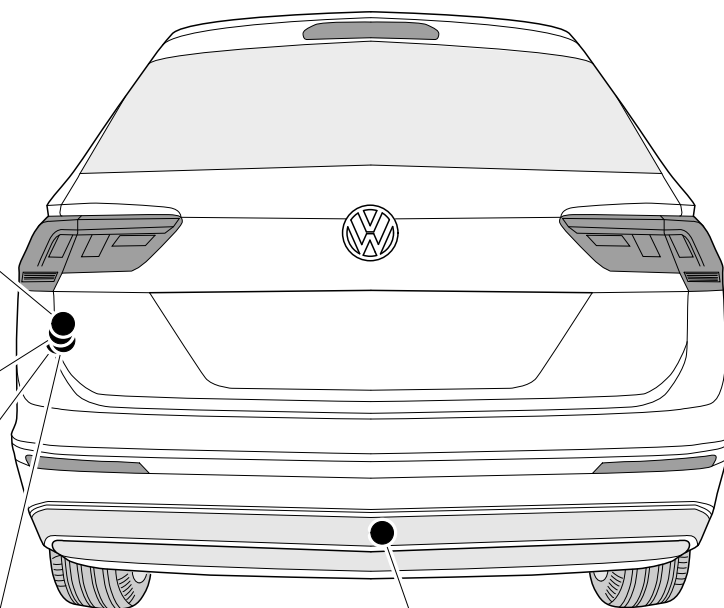
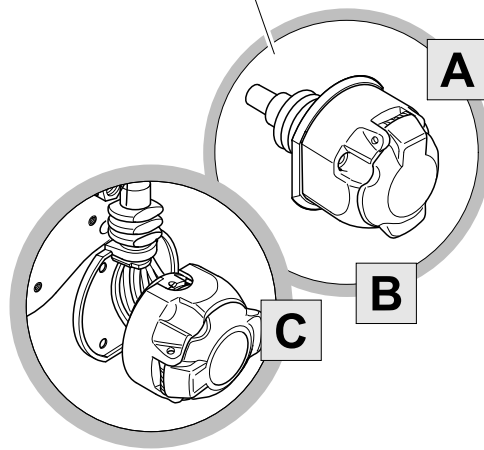
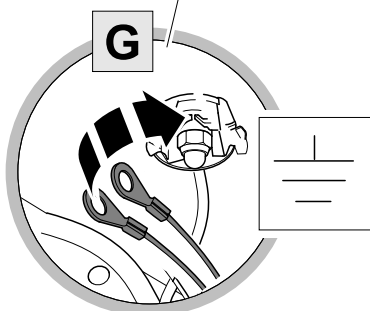
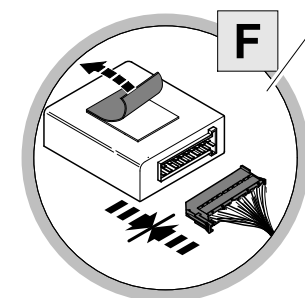
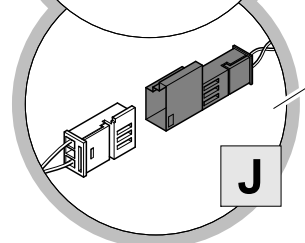
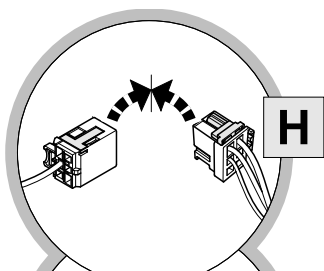

OVERVIEW

For vehicles without trailer preparation

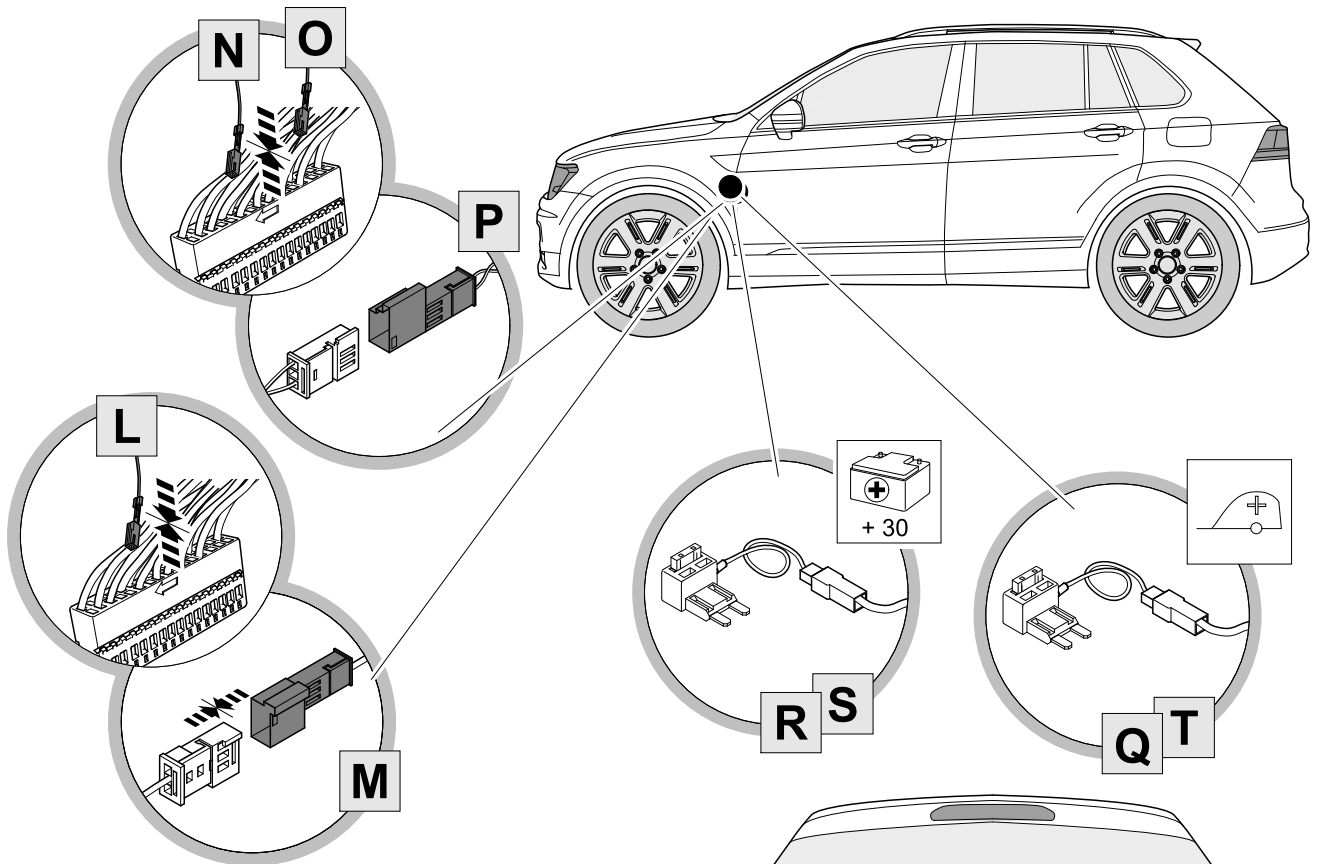

OPTION 3

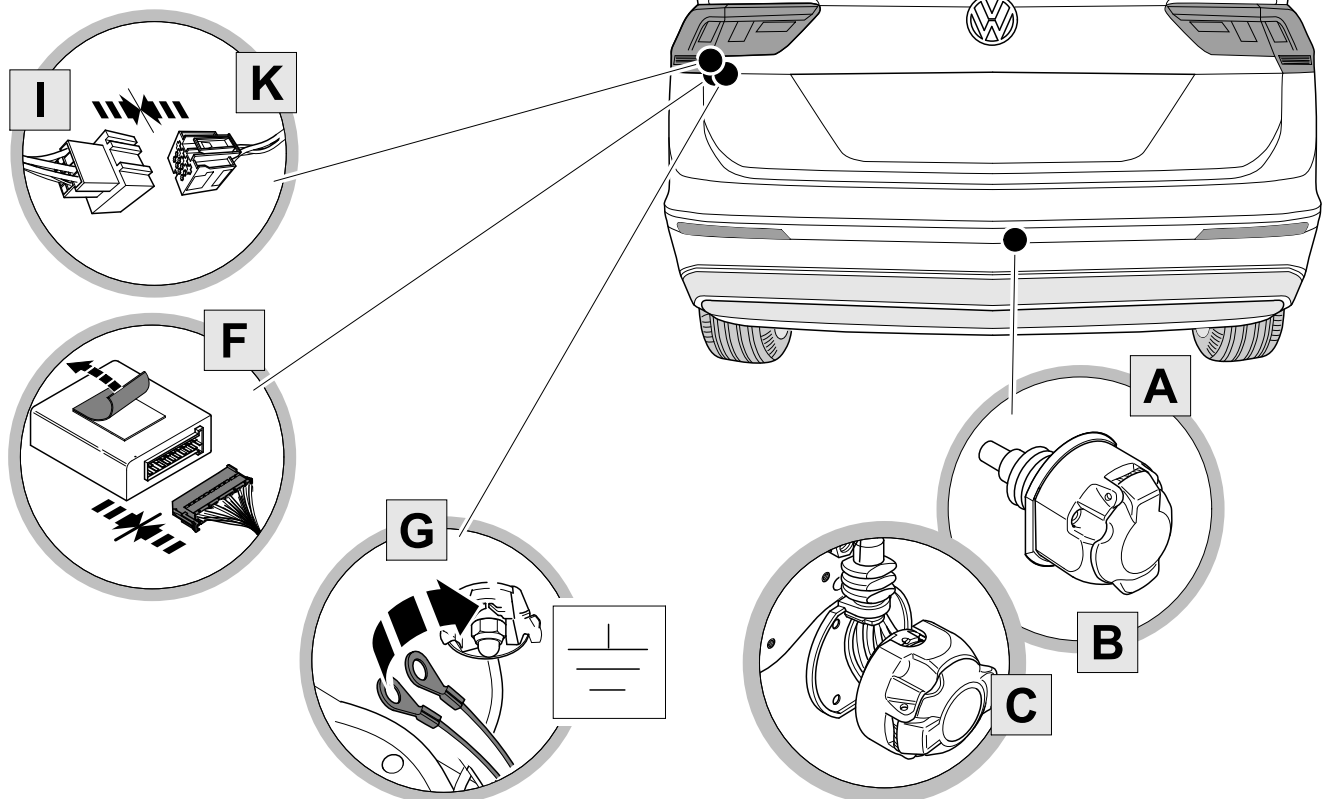

KIT

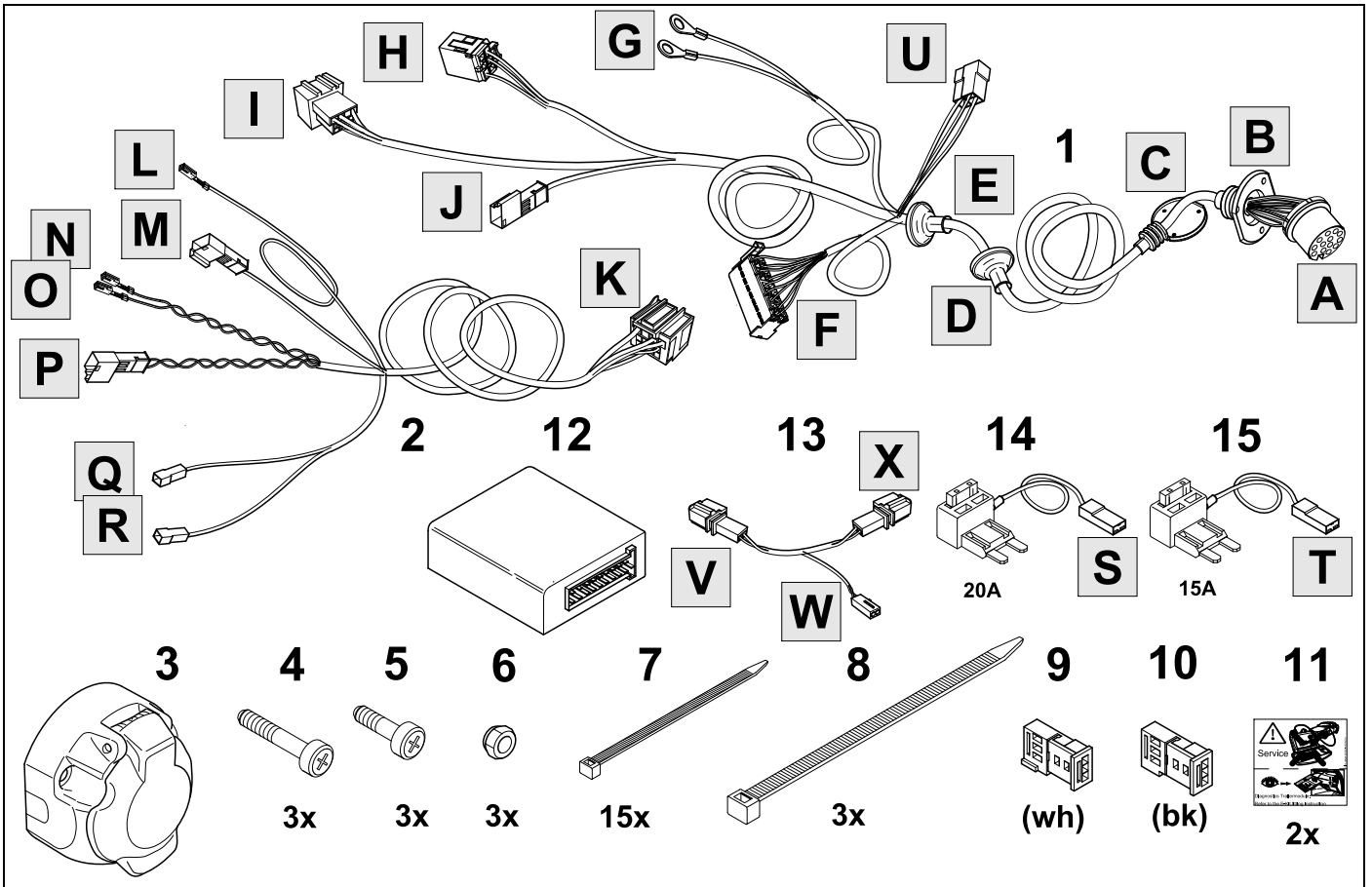

TOOLS

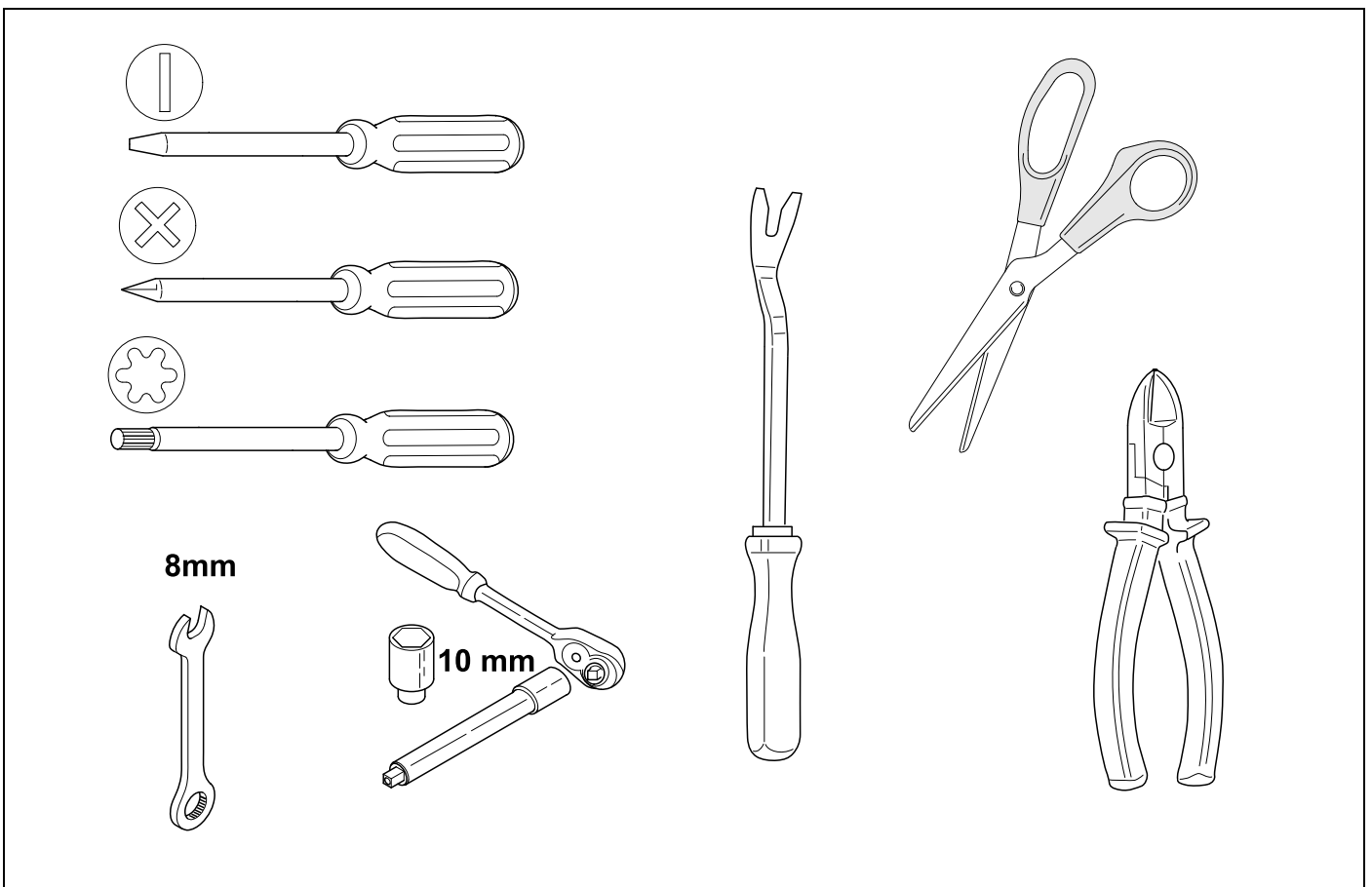

1

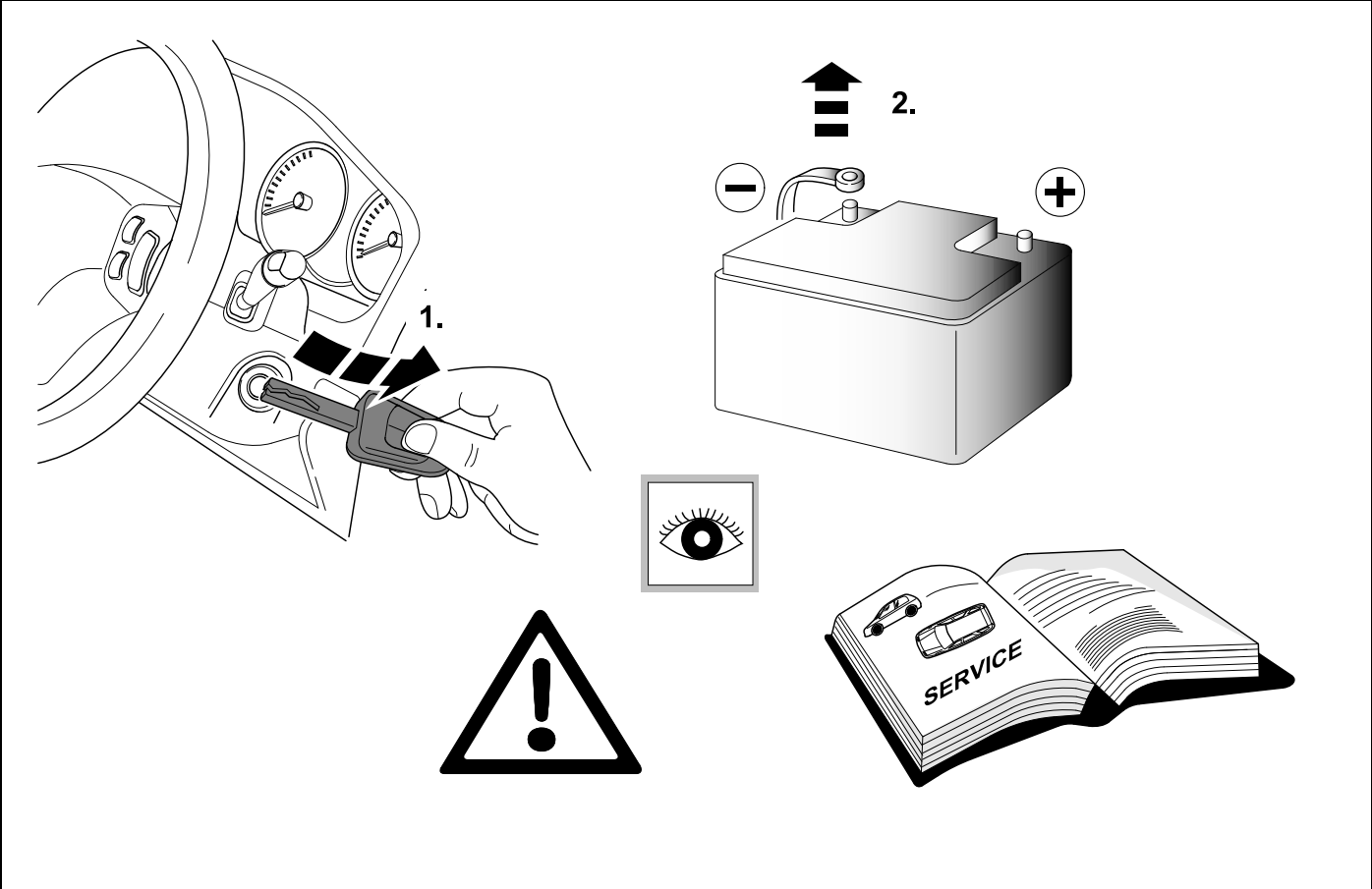

2 REMOVE

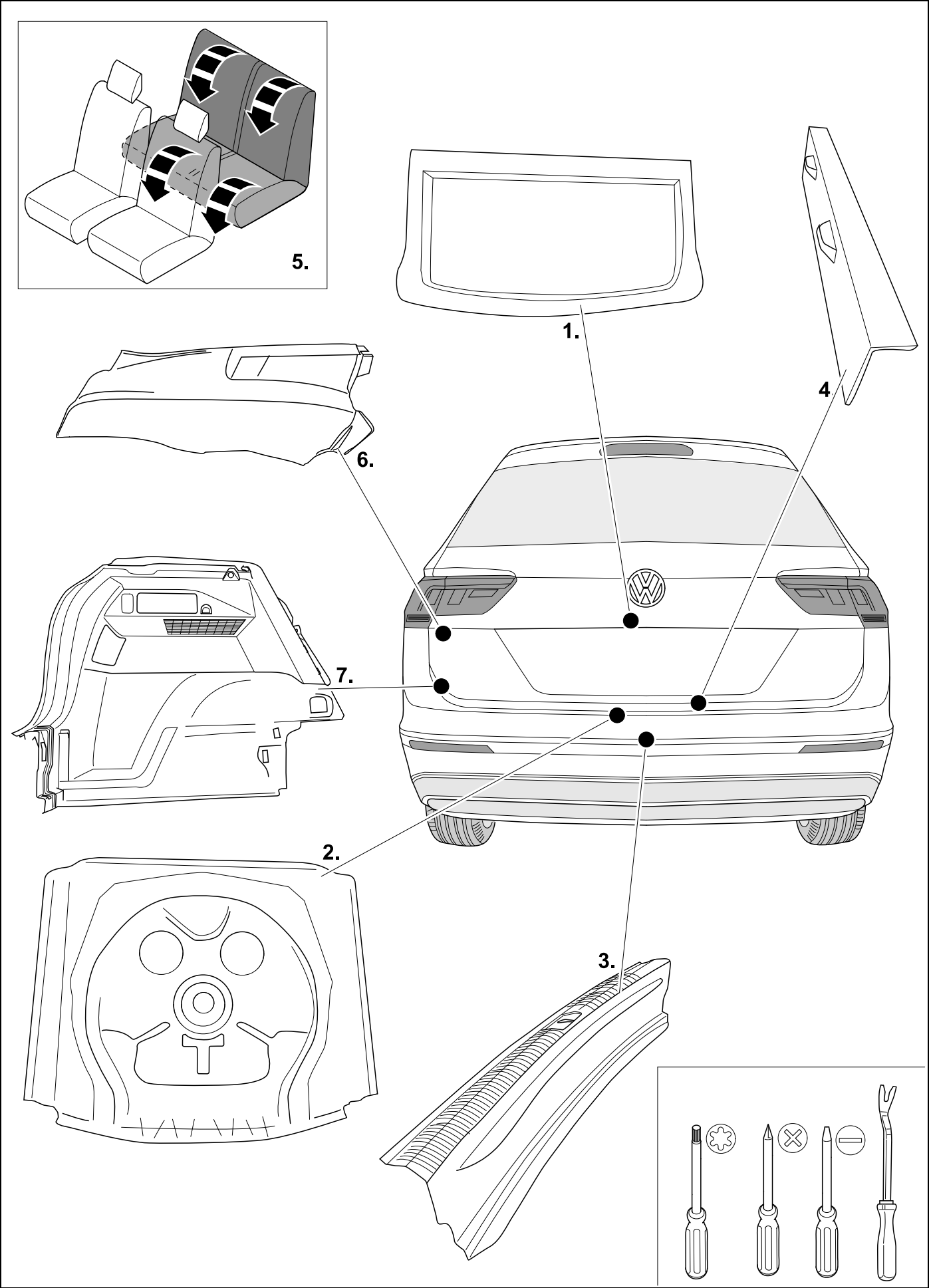

3

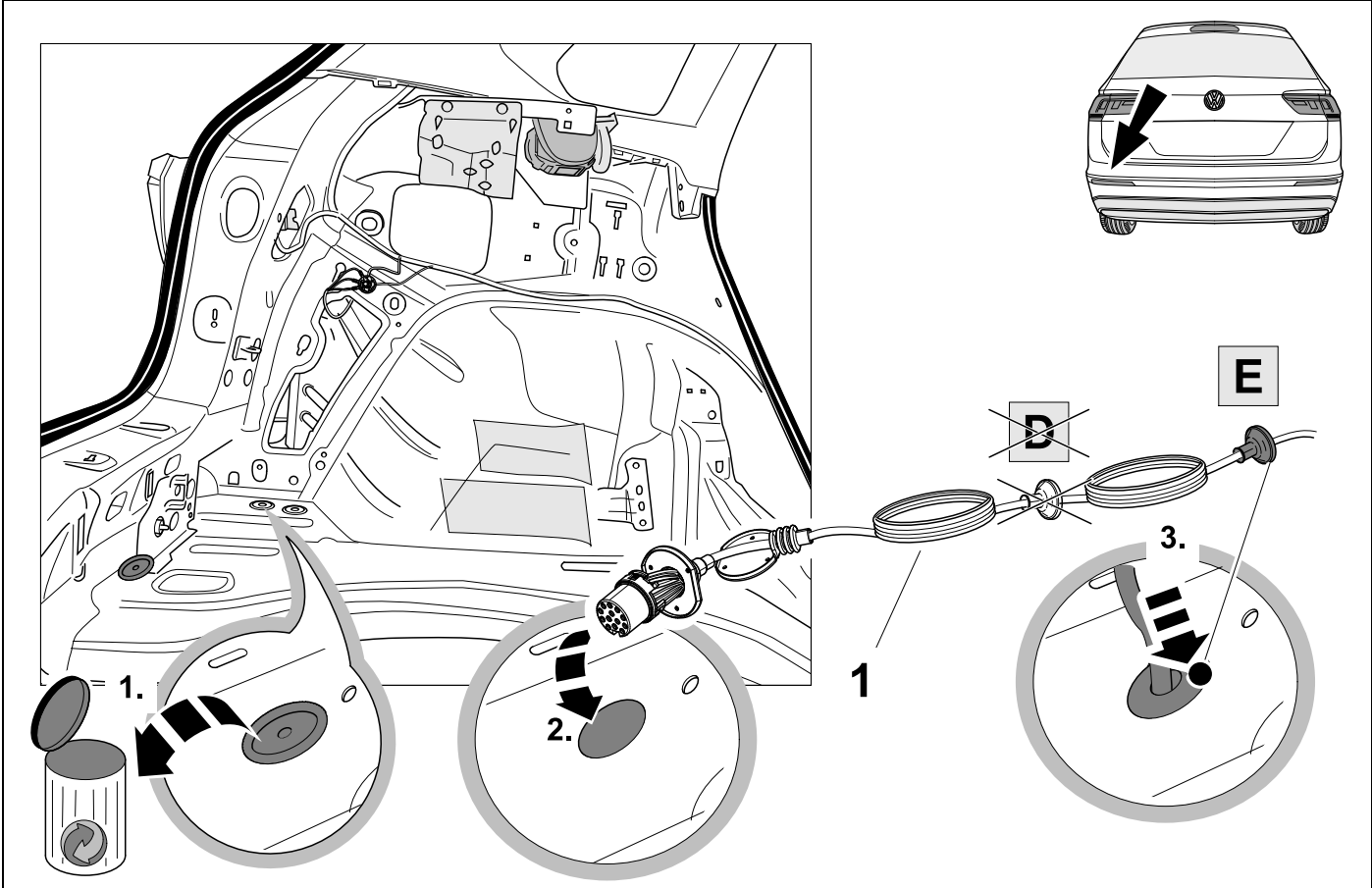

4

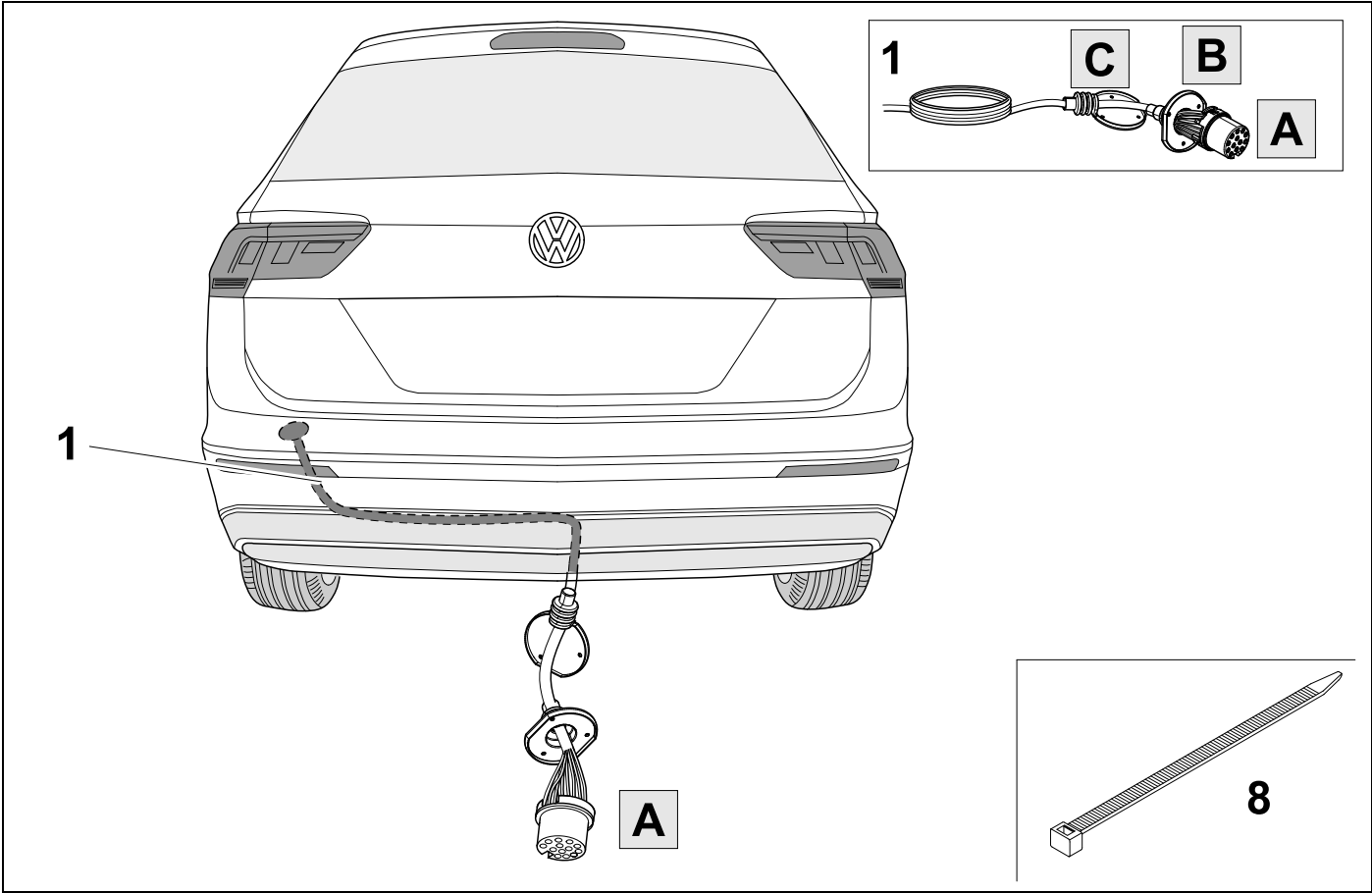

5

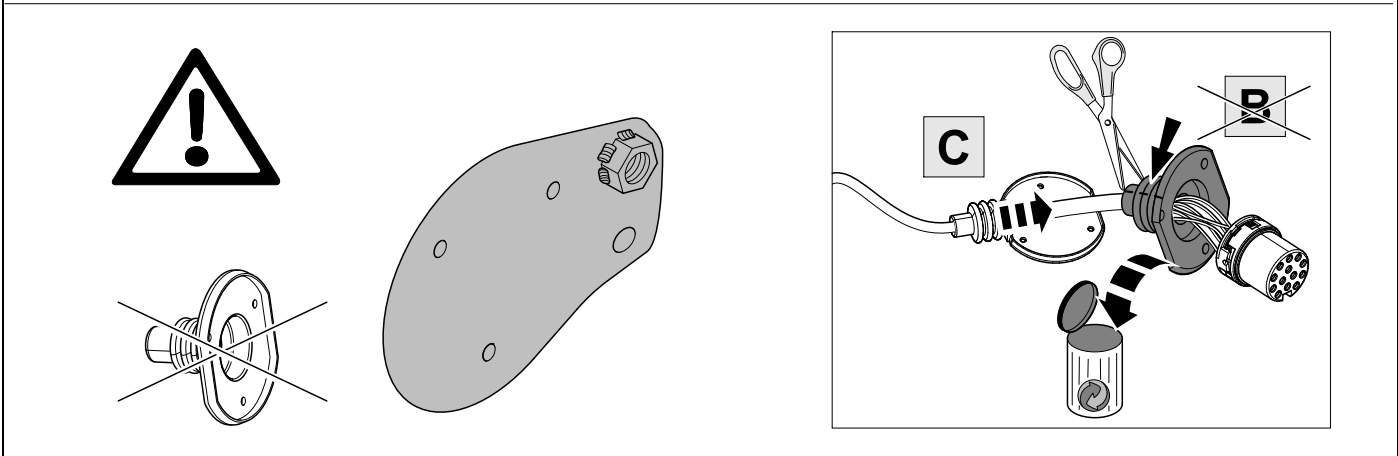
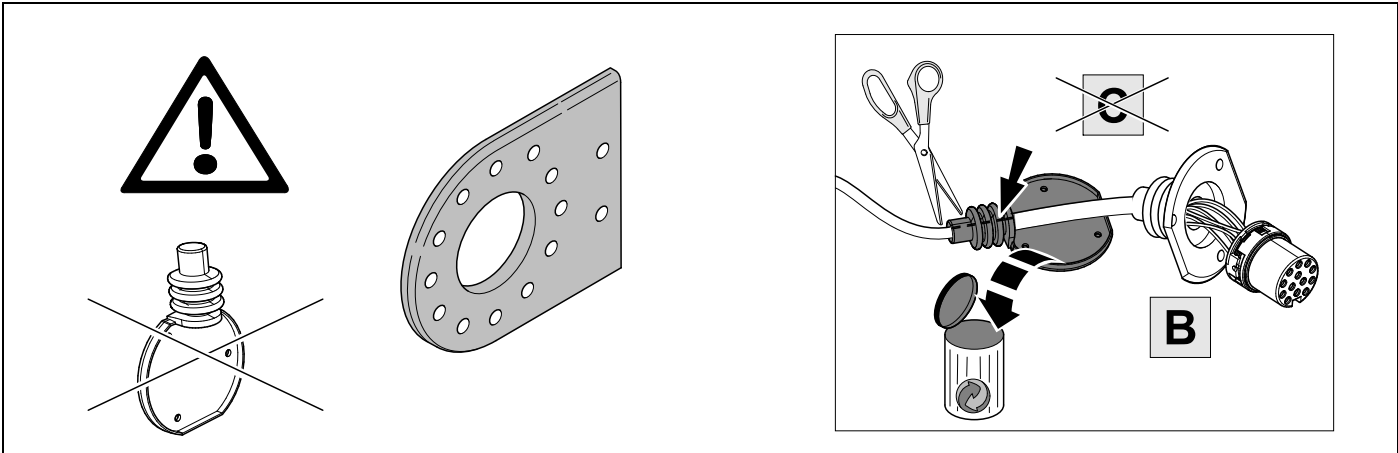

6



8

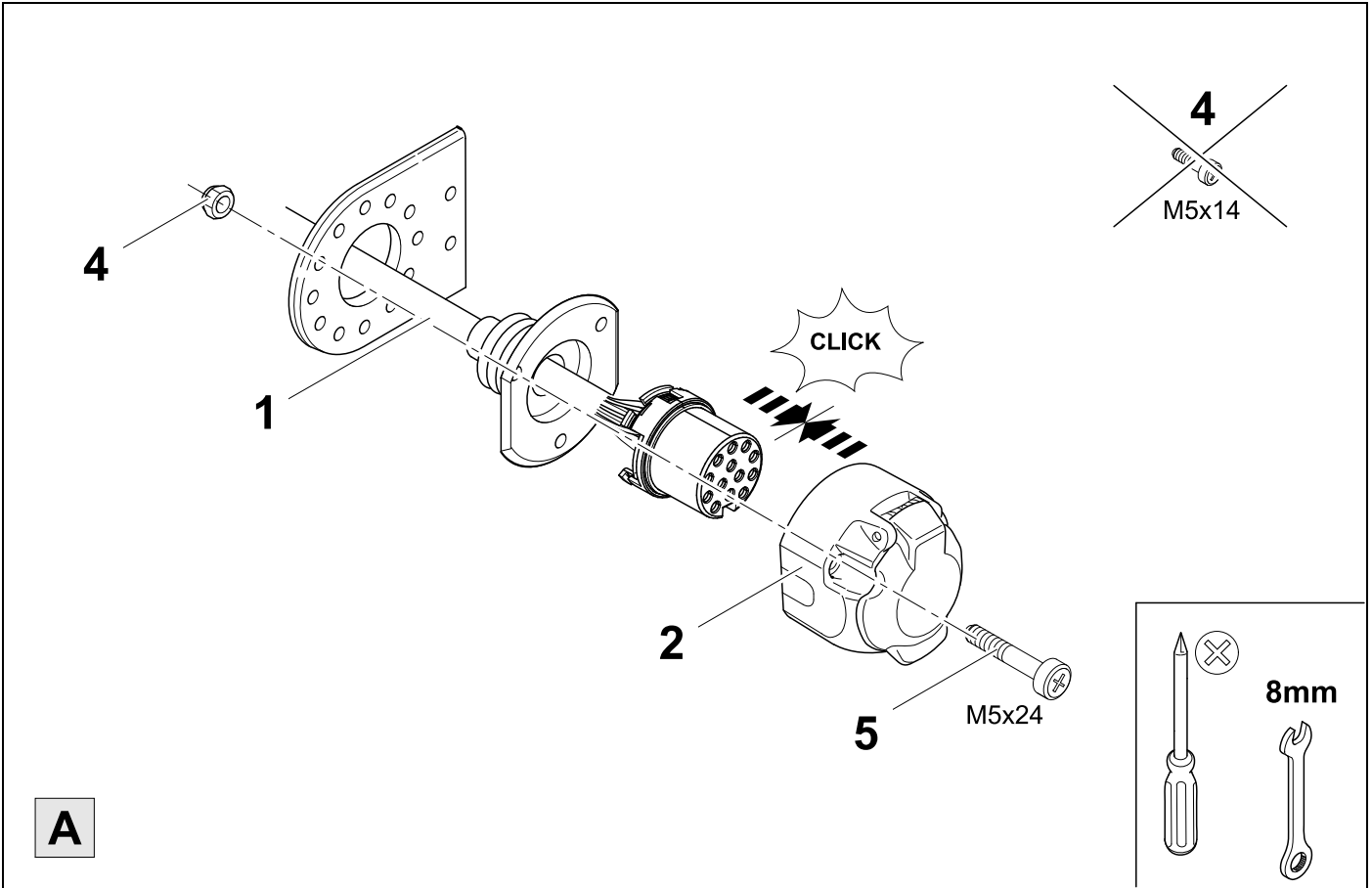

7



8

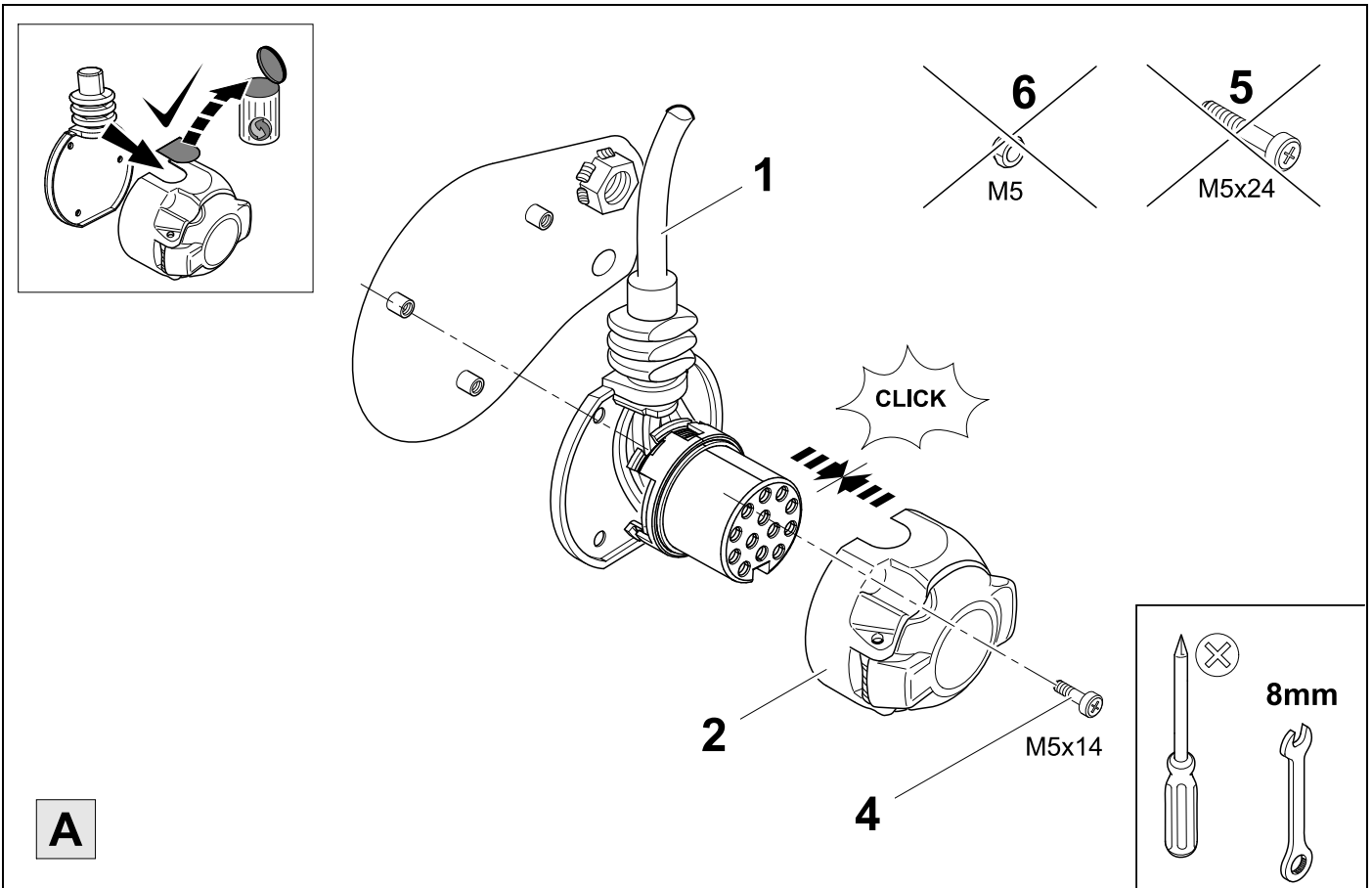

8



9

1	bk/wh		8	bu/rd	
2	gy		9	rd/bu	
3	wh/bn		10	ye	
4	bk/gn		11	bn/gn	
5	gy/rd		12	no	
6	bk/rd		13	bn	
7	gy/bk				

9	bk	wh	gy	gn	rd	bu	ye	bn	pu	or	no
---	----	----	----	----	----	----	----	----	----	----	----

(D)	schwarz	weiß	grau	grün	rot	blau	gelb	braun	violett	orange	nicht belegt
(GB)	black	white	grey	green	red	blue	yellow	brown	purple	orange	not occupied
(F)	noir	blanc	gris	vert	rouge	bleu	jaune	brun	violet	orange	inutilisé
(NL)	zwart	wit	grijs	groen	rood	blauw	geel	bruin	violet	oranje	niet aangesloten
(DK)	sort	hvid	grå	grøn	rød	blå	gul	brun	violet	orange	ikke anvendt
(N)	svart	hvit	grå	grønn	rød	blå	gul	brun	fiolett	oransje	ikke i bruk
(S)	svart	vit	grå	grön	röd	blå	gul	brun	violett	orange	ej använd
(FIN)	musta	valkoinen	harmaa	vihreä	punainen	sininen	keltainen	ruskea	violetti	oranssi	ei varattu
(I)	nero	bianco	grigio	verde	rosso	blu	giallo	marrone	viola	arancione	libero
(E)	negro	blanco	gris	verde	rojo	azul	amarillo	marrón	violeta	anaranja-do	no ocupado
(P)	preto	branco	cinzento	verde	vermelho	azul	amarelo	castanho	violeta	laranja	não ocupado
(GR)	μαύρος	λευκός	Γκρι	πράσινος	κόκκινος	μπλε	κίτρινος	καφέ	Μωβ	πορτοκαλί	δεν είναι κοτ ειλημμένος
(PL)	czarny	biały	szaro	zielony	czerwony	niebiesko	żółty	brazowy	fioletowy	pomarańczowy	wolny
(CZ)	černý	bílý	šedý	zelený	červený	modrý	žlutý	hnědý	fialový	oranžový	neobsazen
(TR)	siyah	beyaz	gri	yeşil	kırmızı	mavi	sarı	kahverengi	mor	portakal rengi	boş
(H)	fekete	fehér	szürke	zöld	piros	kék	sárga	barna	ibolyakék	narancssárga	nem foglalt
(HR)	crno	bijelo	sivo	zeleno	crveno	plavo	zuto	smeđe	ljubičasto	narandasto	nije zauzeto
(BUL)	черен	бял	сив	зелен	червен	син	жълт	кафяв	виолетов	оранжев	свободно
(RO)	negru	alb	gri	verde	roșu	albastru	galben	maro	violet	portocaliu	liber
(RU)	черный	белый	серый	зеленый	красный	голубой	жёлтый	коричневый	пурпурный	оранжевый	свободно
(LT)	juoda	balta	pilka	žalia	raudona	mėlyna	geltona	ruda	purpurinė	oranžinė	laisva
(LV)	melna	balta	pelēka	zaļa	sarkana	zila	dzeltena	brūna	purpur-sarkana	oranža	brīvs
(EST)	must	valge	hall	roheline	punane	sinine	kollane	pruun	purpur-punane	oraanž	vaba
(SLO)	črna	bela	siva	zelena	rdeča	modra	rumena	smeđ	vijoličast	oranžen	ni zasedeno
(SK)	čierny	biely	šedý	zelený	červený	modrý	žltý	hnědý	fialový	pomaraňový	neobsadený

10

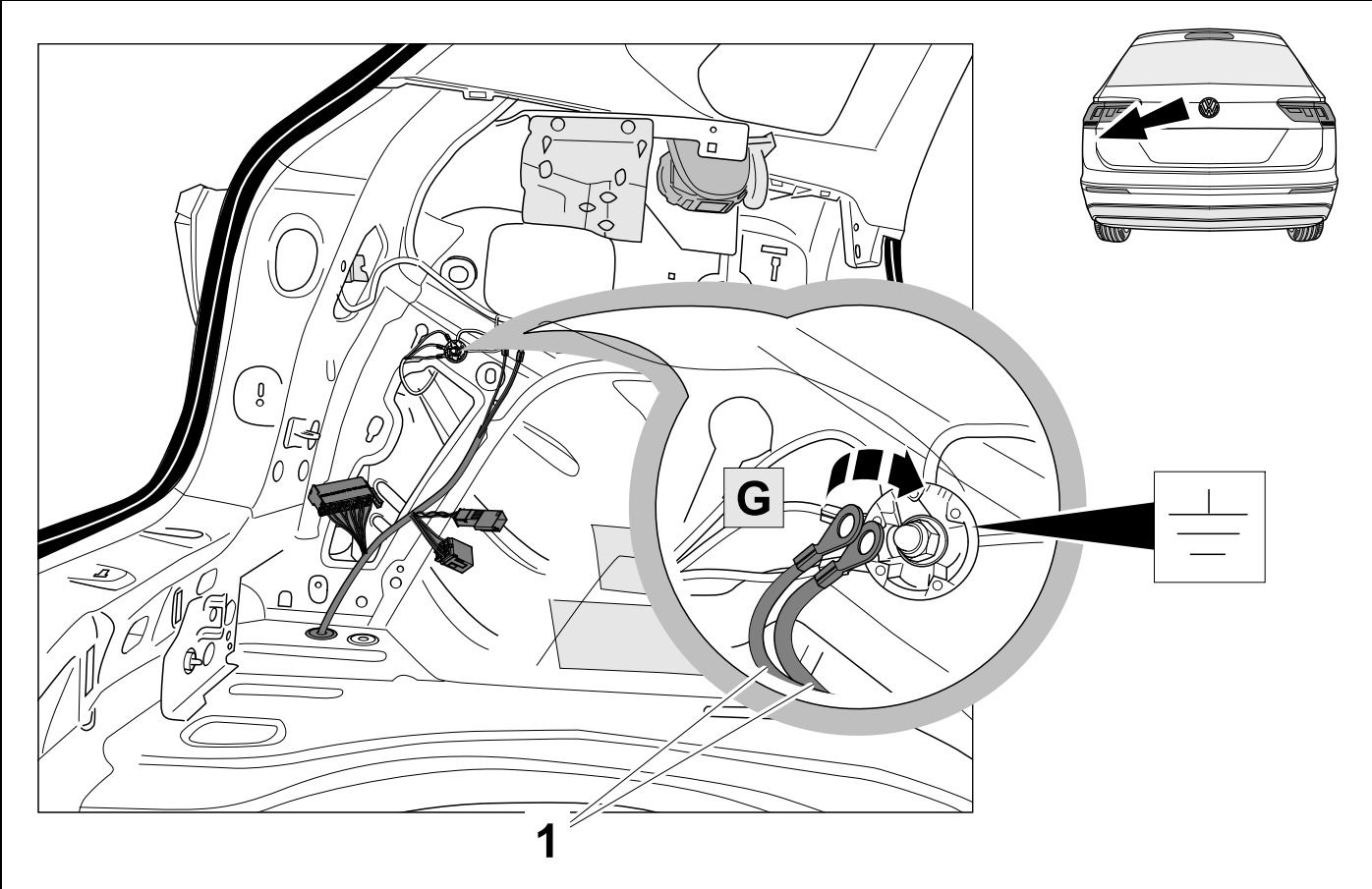

11

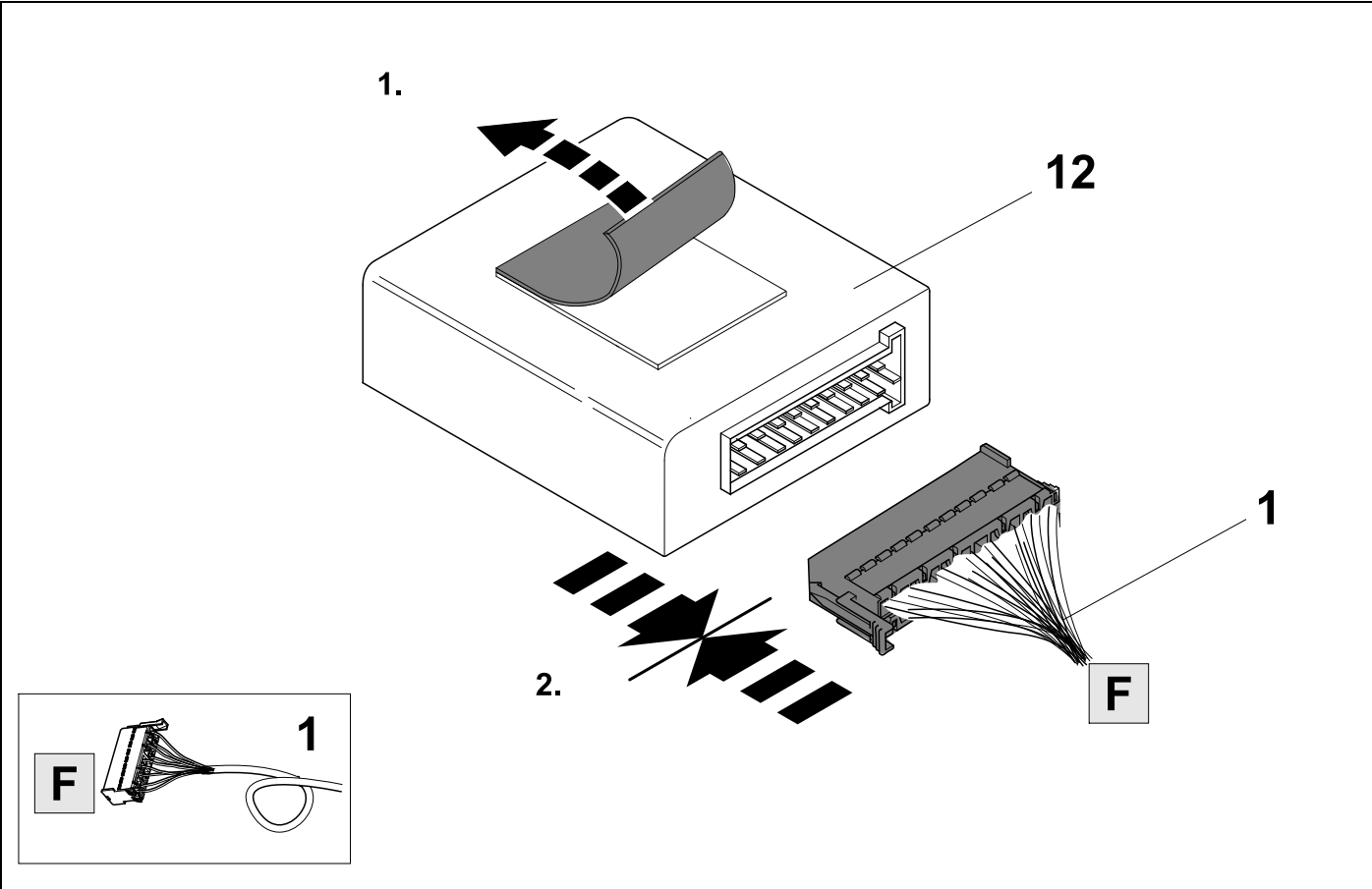

12

Tiguan

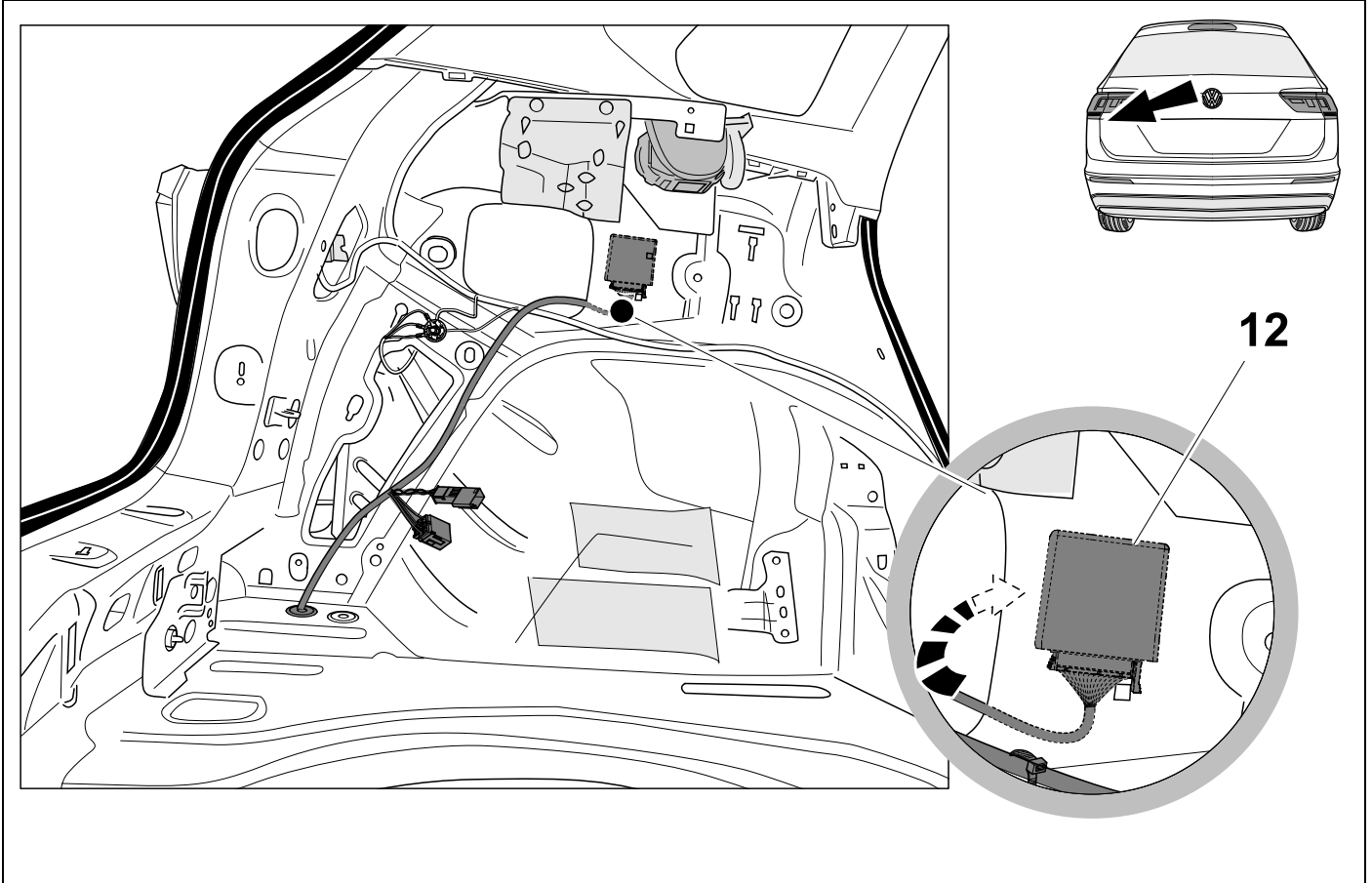

13

T-Roc

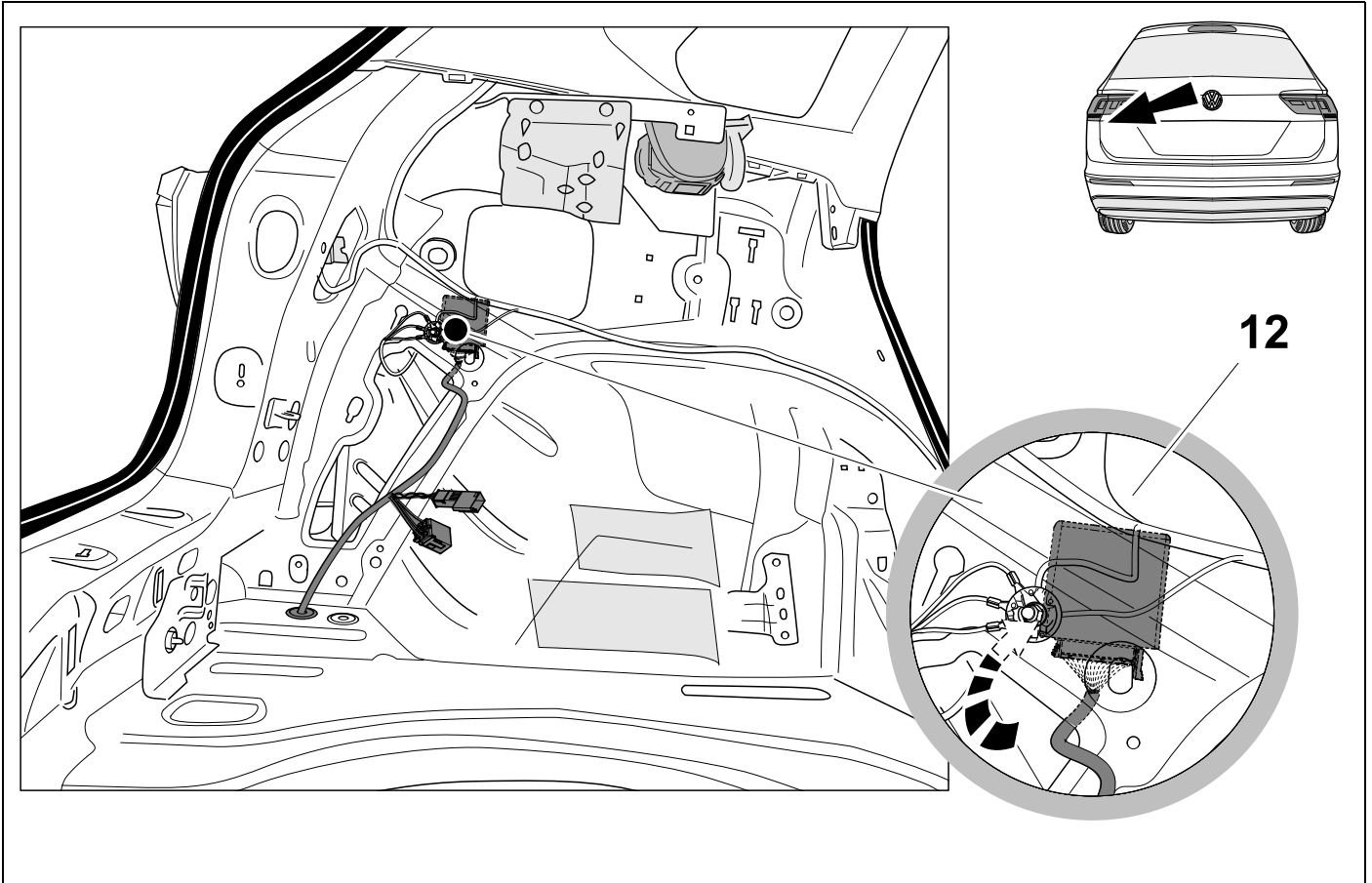

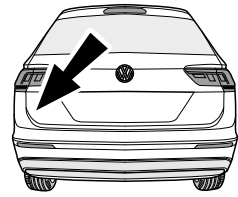

Vehicles with trailer preparation 1M5

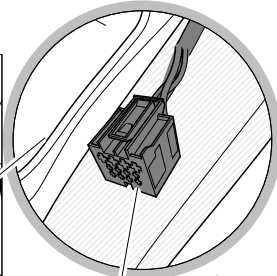
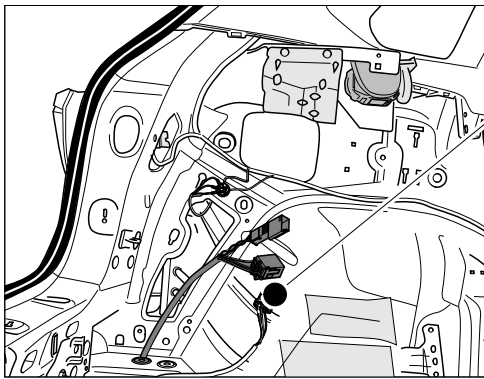

rd
12 PIN

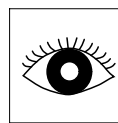

OPTION 1

15	⇒	16
41	⇒	54

Vehicles with trailer preparation 1M5

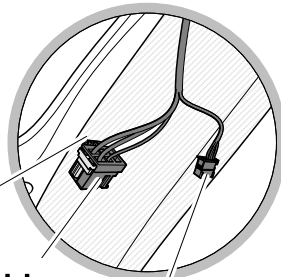
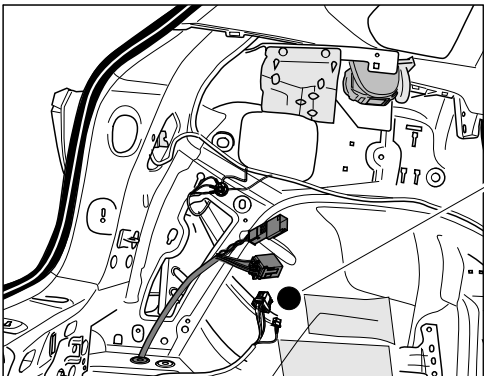

bk
6 PIN

bk
10 PIN

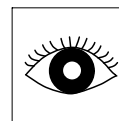

OPTION 2

17	⇒	24
41	⇒	54

Vehicles without trailer preparation 1D0

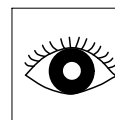
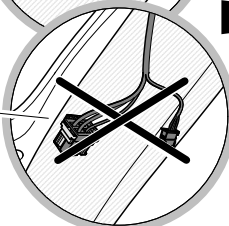
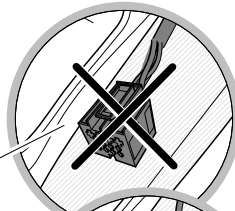
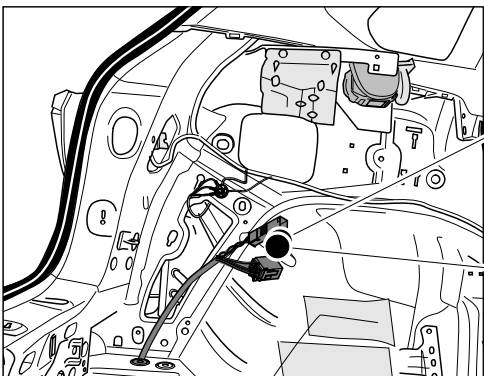

OPTION 3

25	⇒	54
----	---	----

15



9

OPTION 1

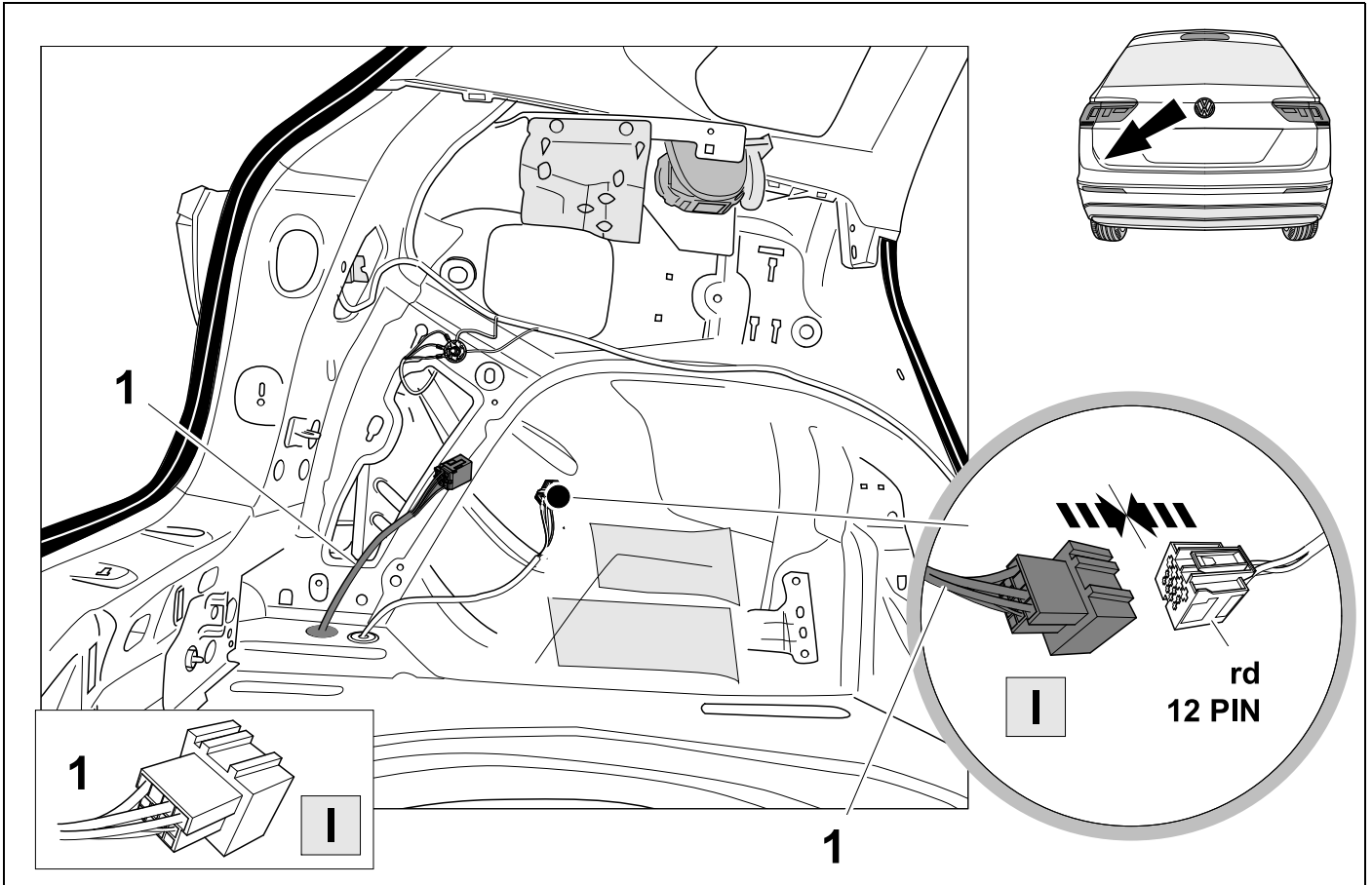

16



9

OPTION 1

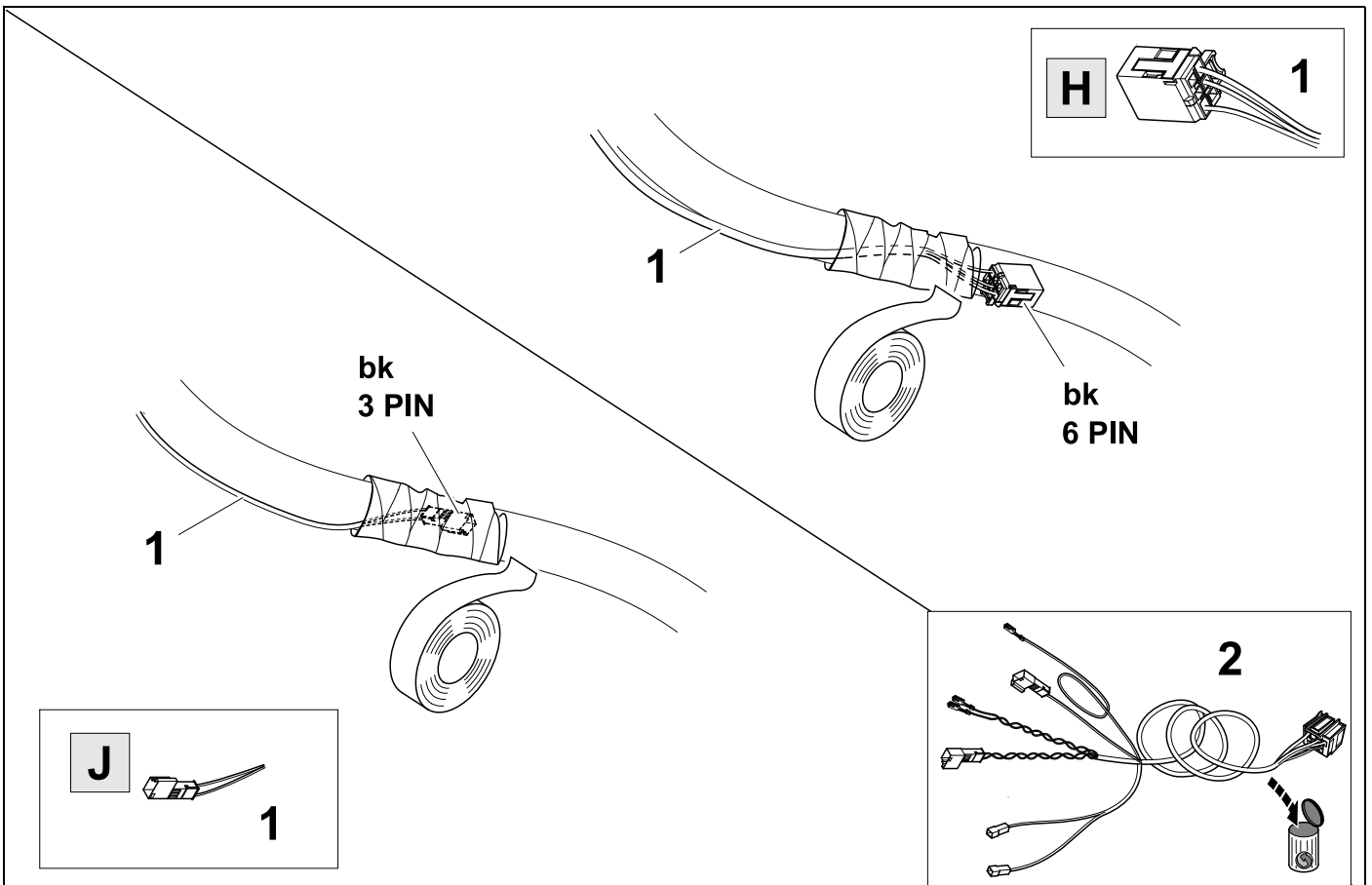

17



OPTION 2

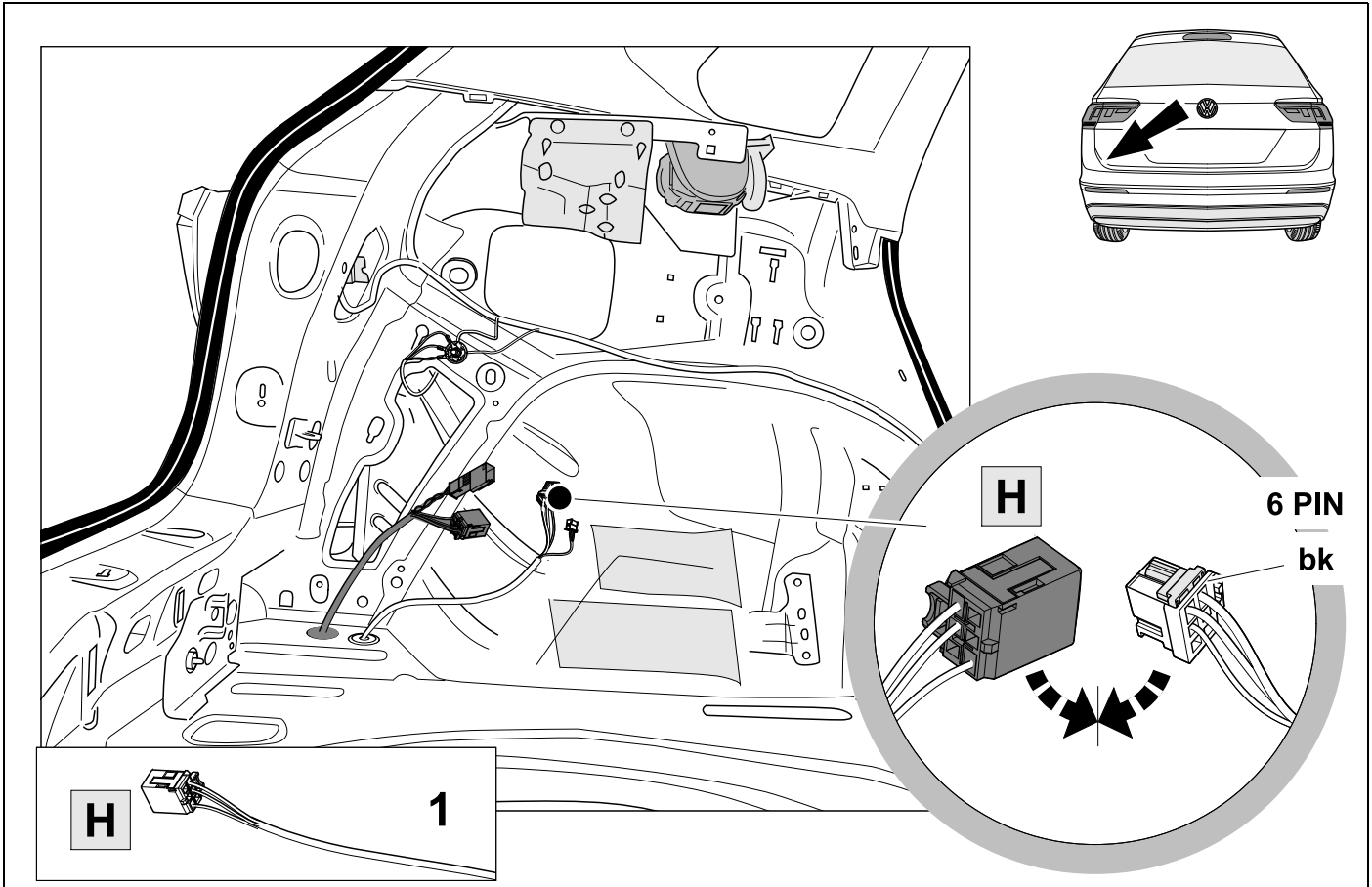

18



OPTION 2

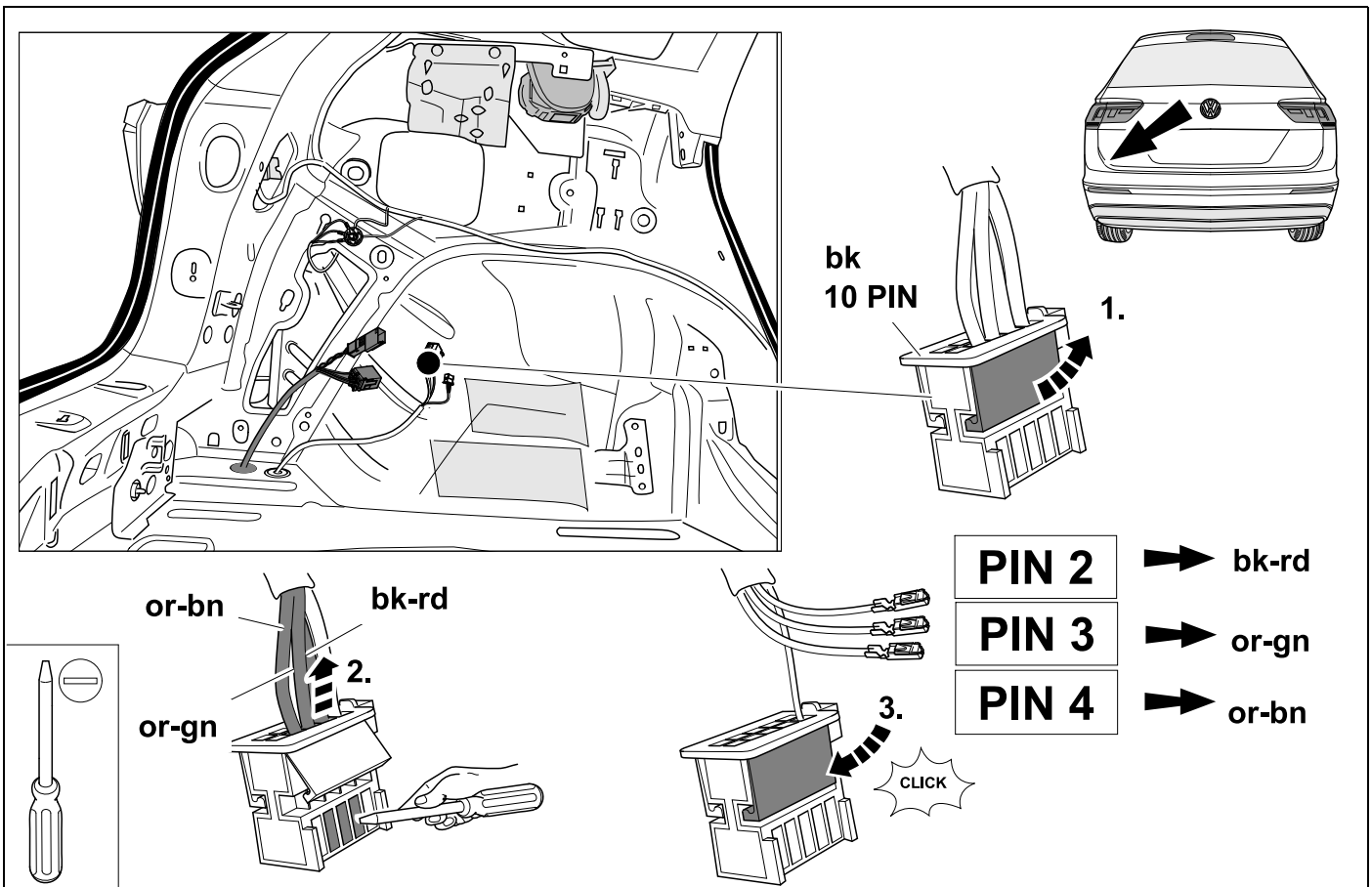

19



9

OPTION 2

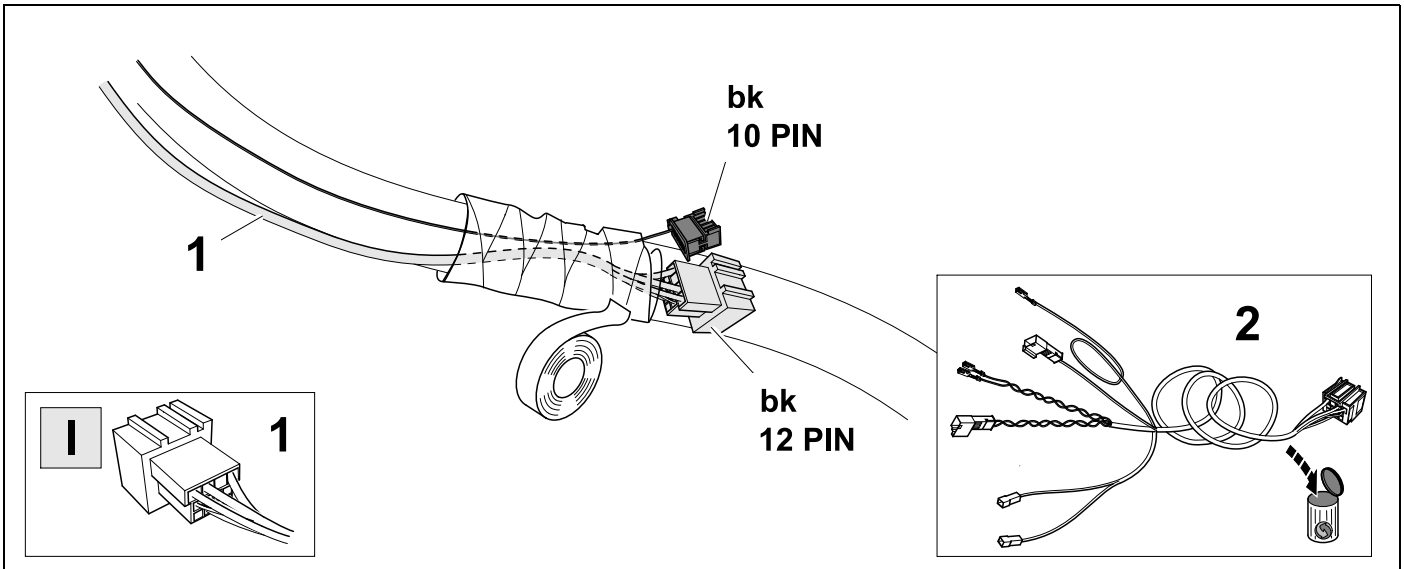

20



9

OPTION 2

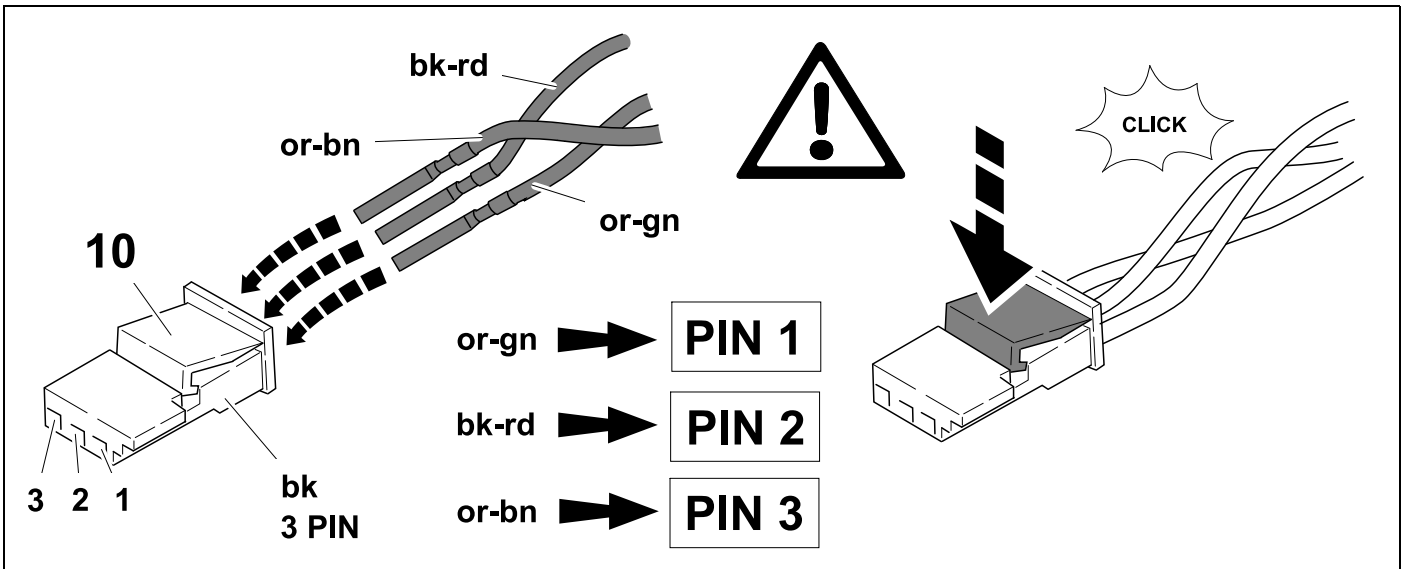

21

OPTION 2

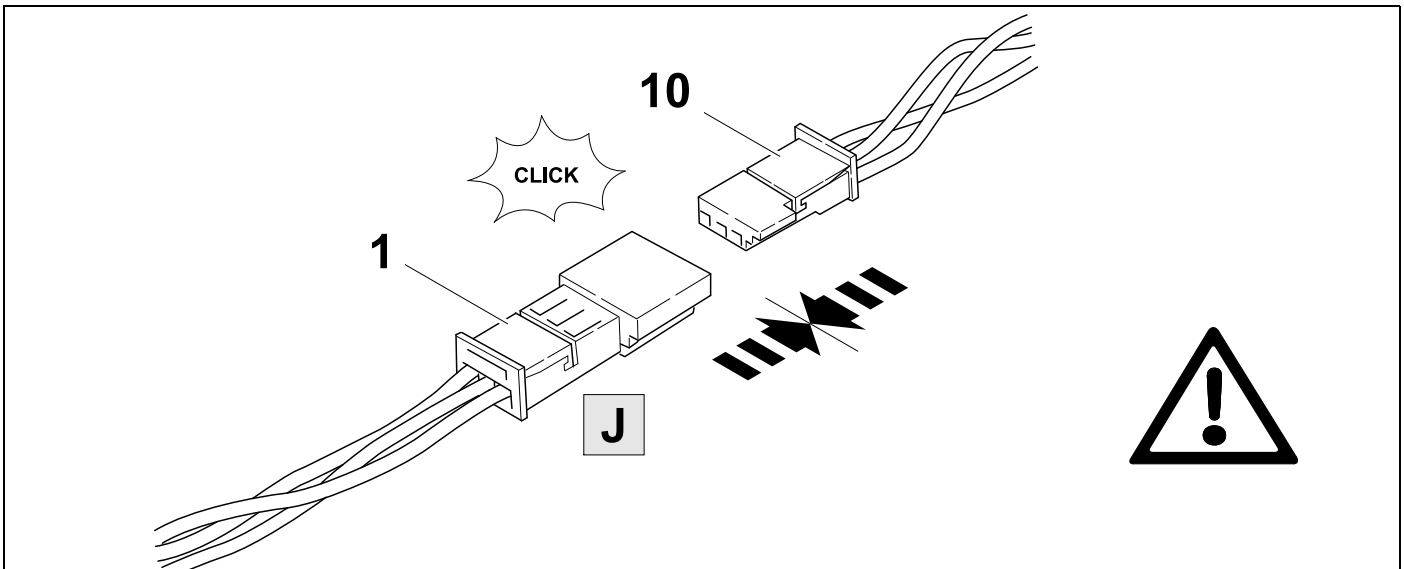

22 Tiguan

OPTION 2

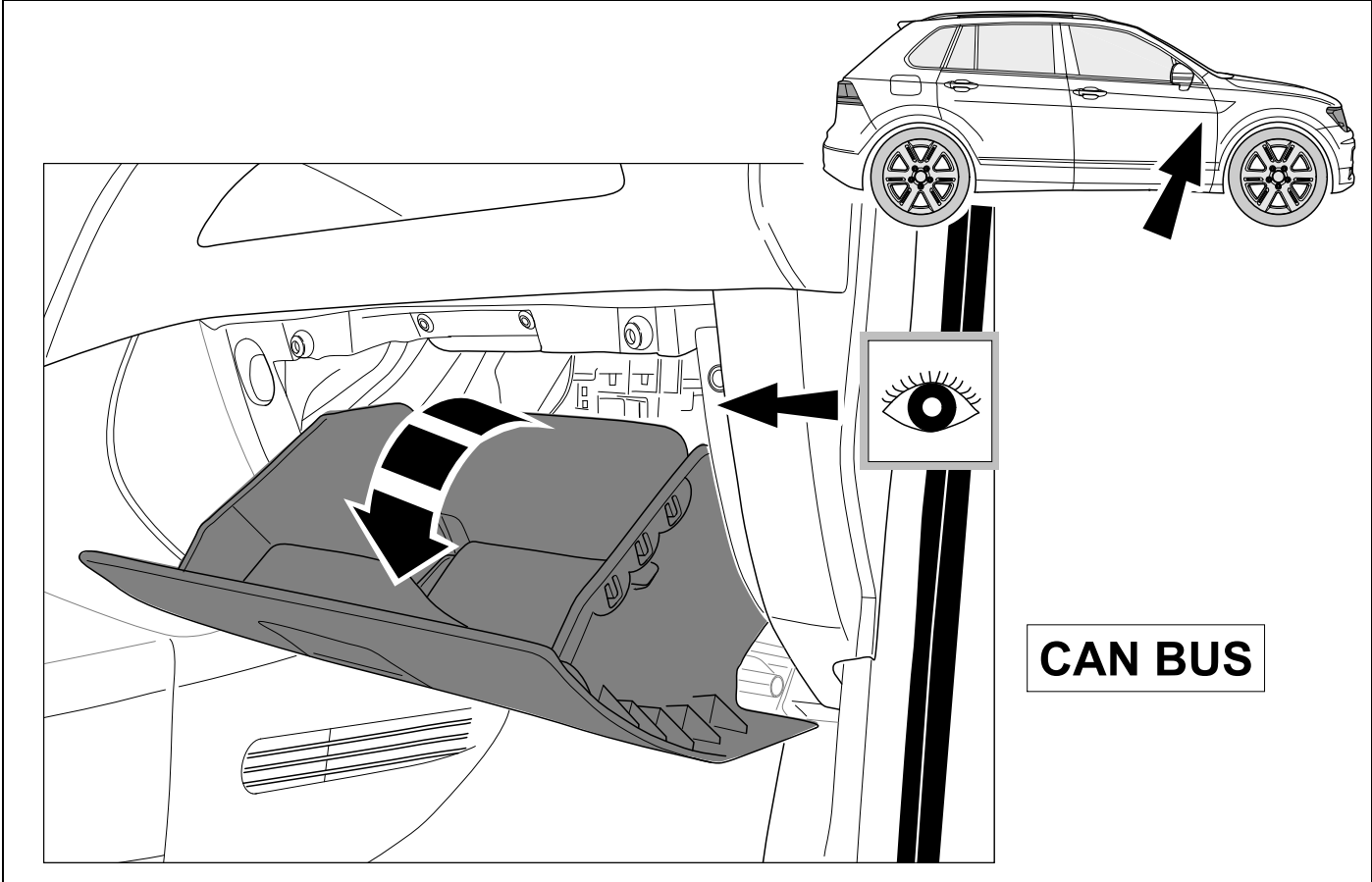

23 Tiguan

 \Rightarrow **9**

OPTION 2

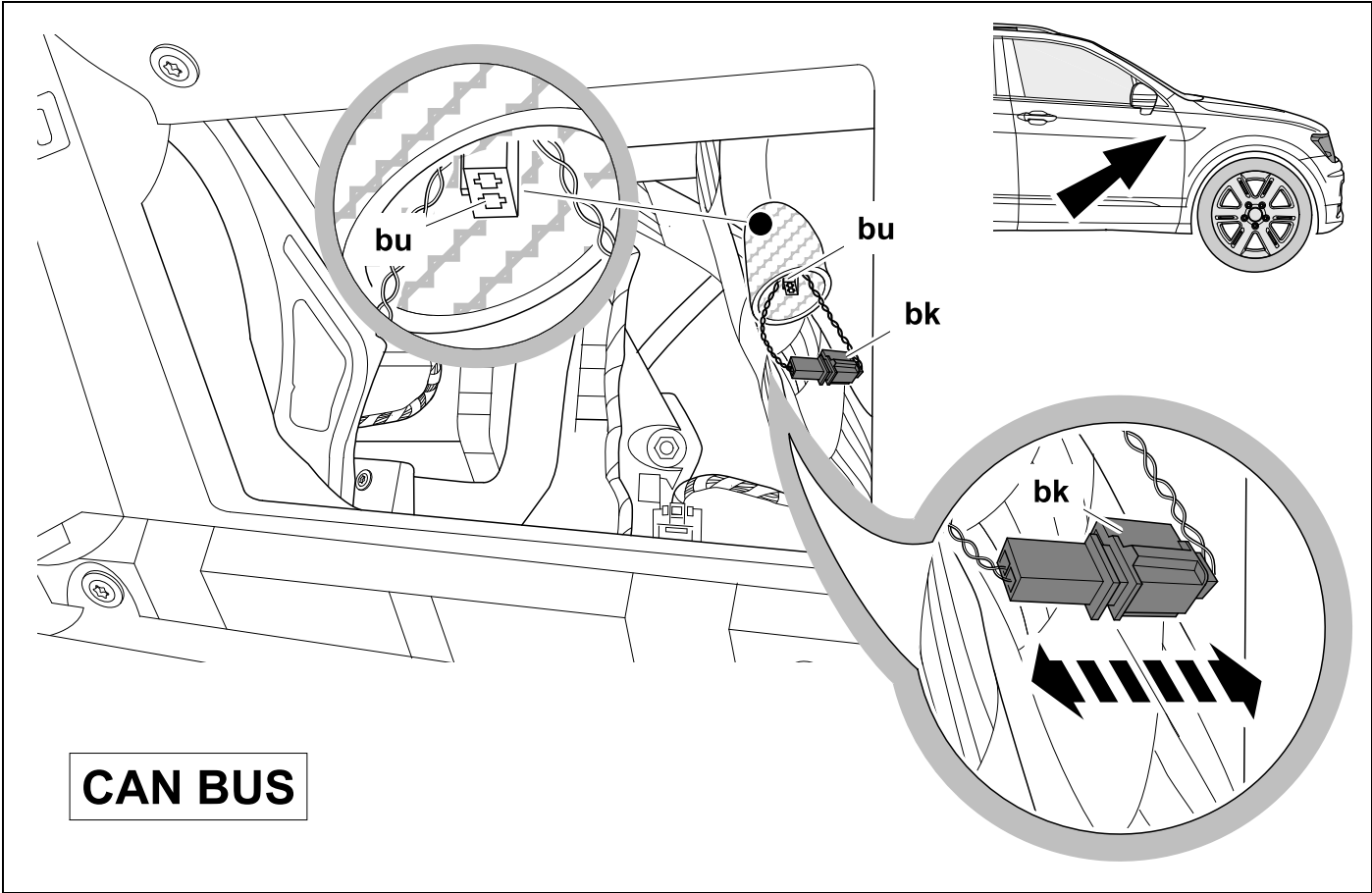

24

Tiguan



9

OPTION 2

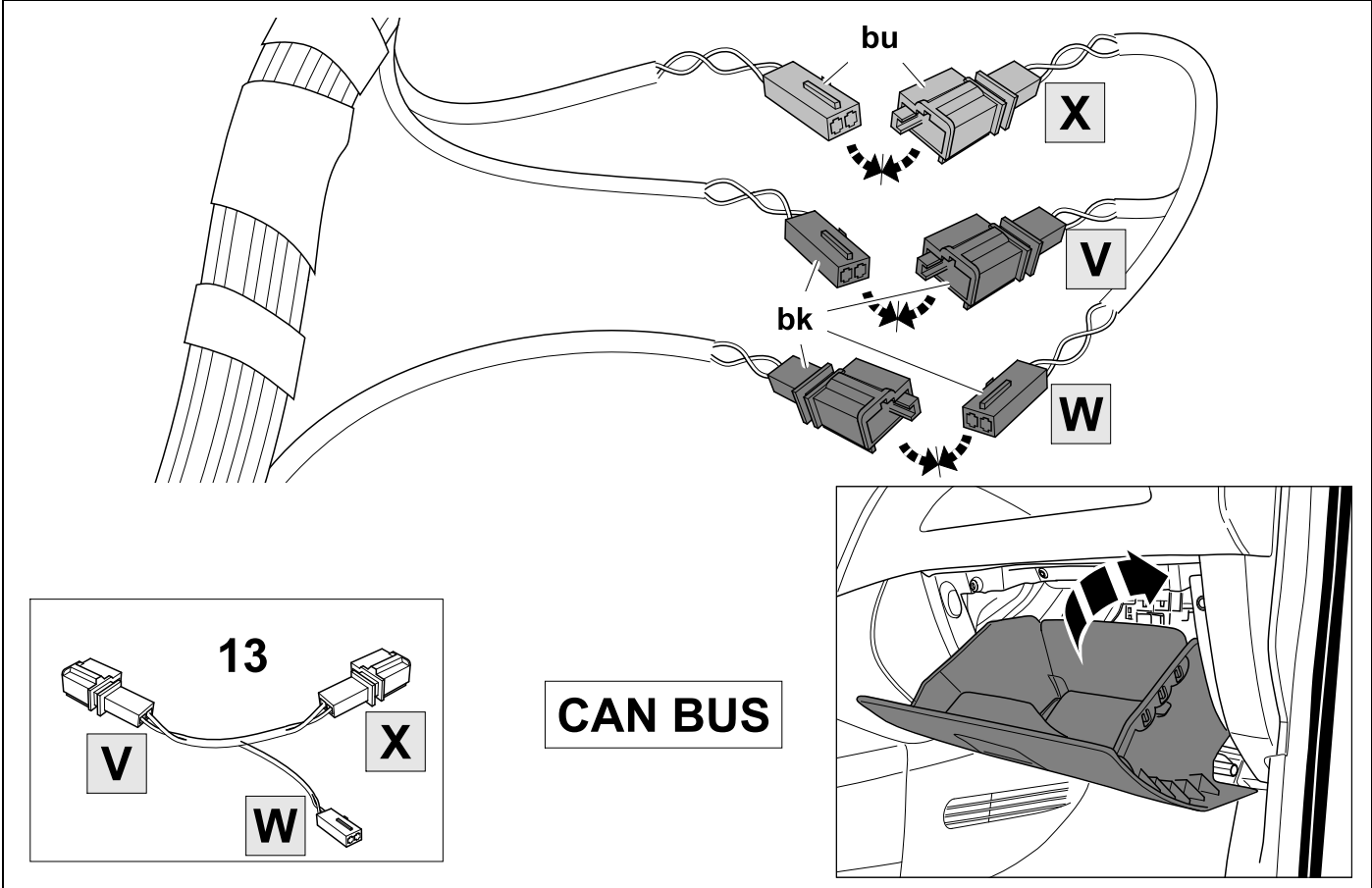

25



9

OPTION 3

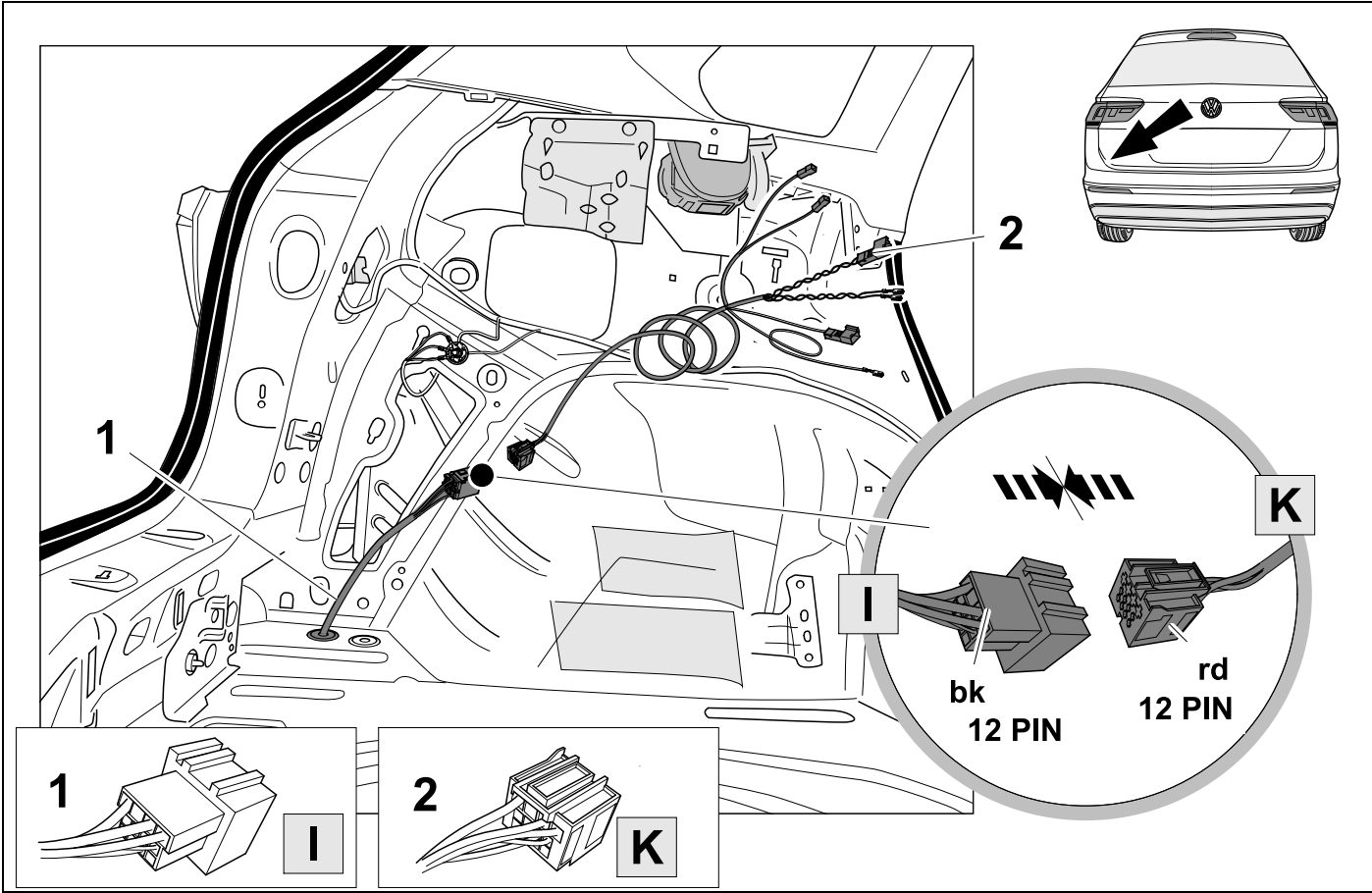

26



9

OPTION 3

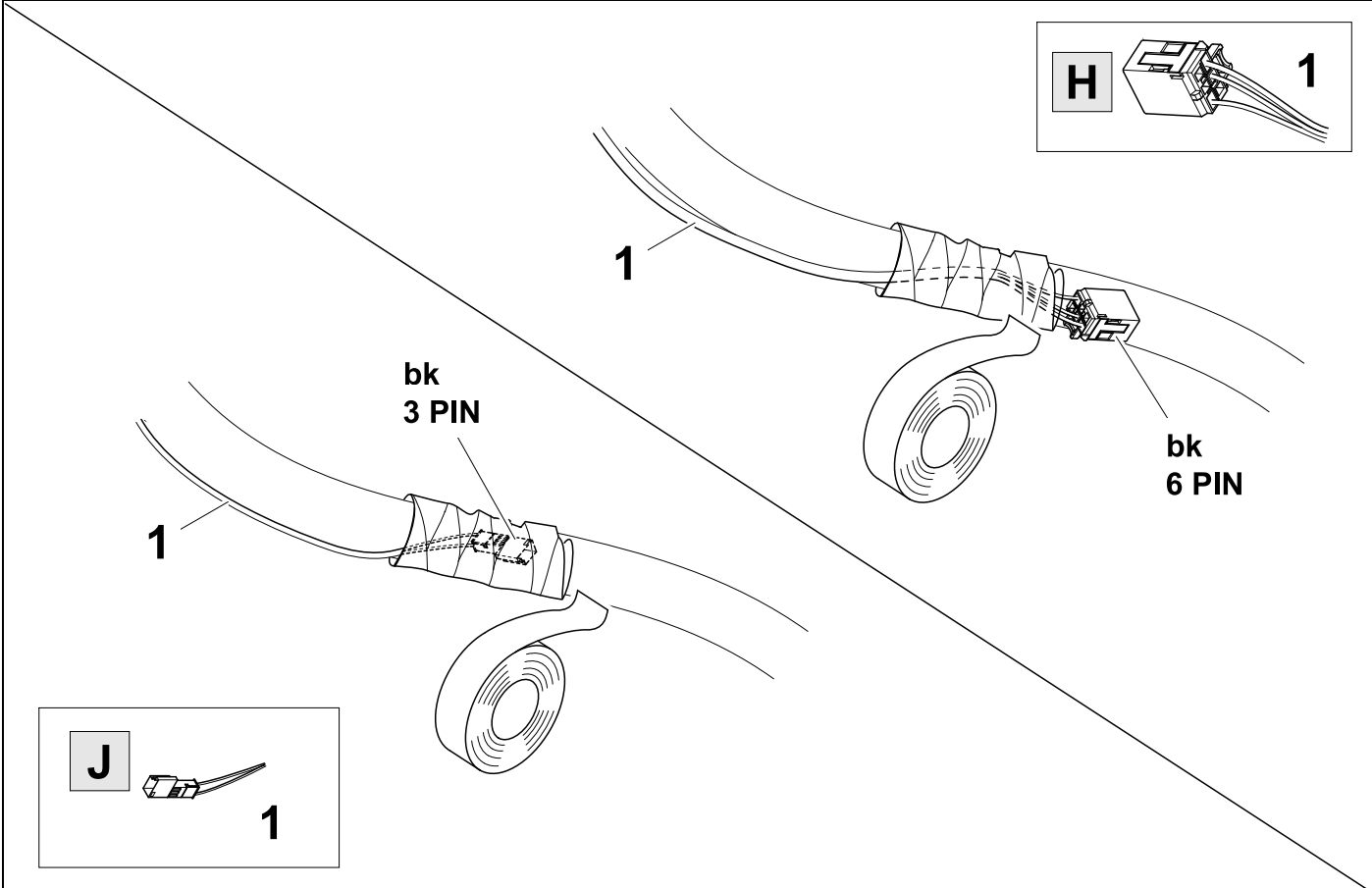

27

OPTION 3

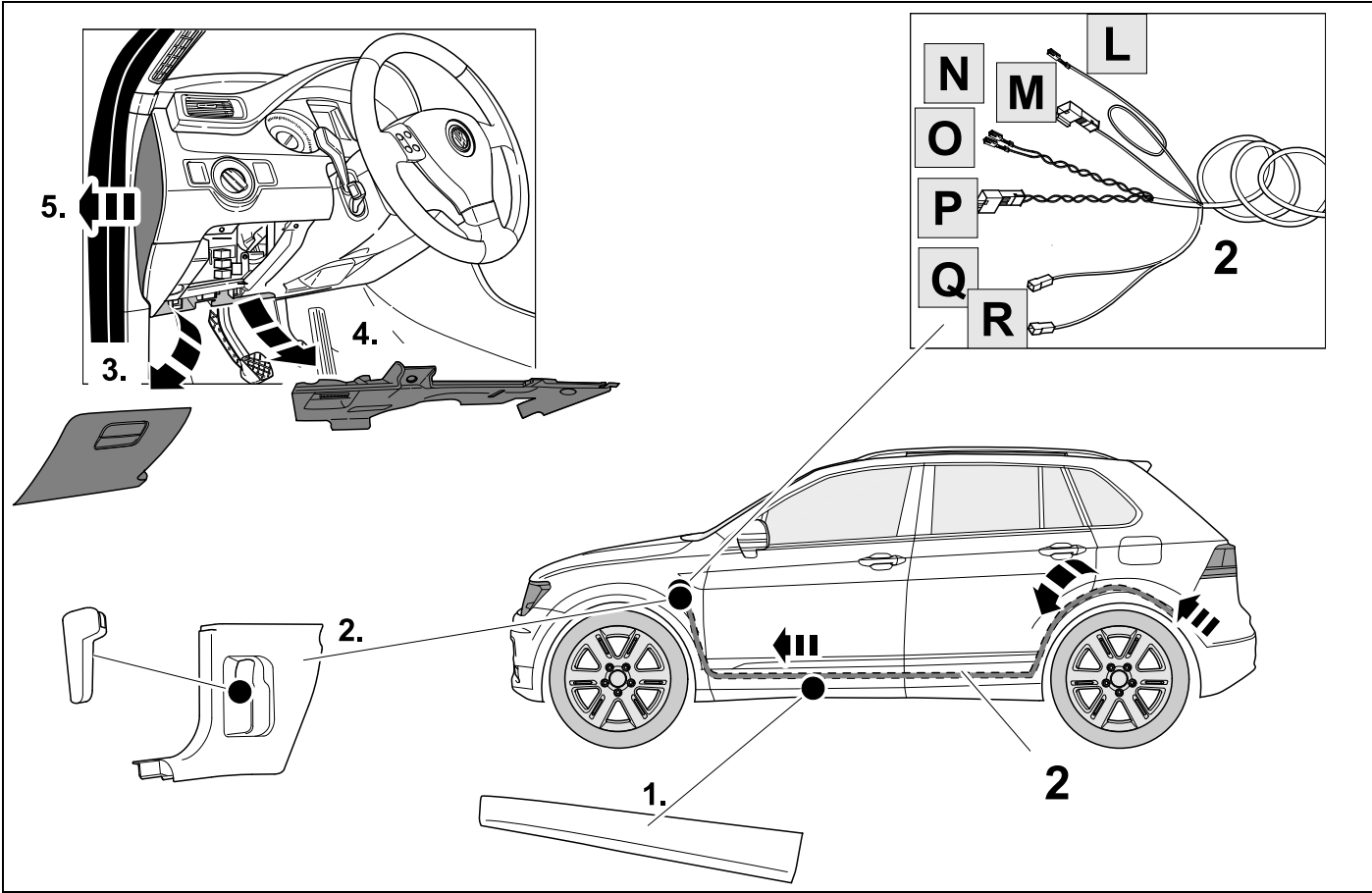

28

👁️ ⇒ 9

OPTION 3

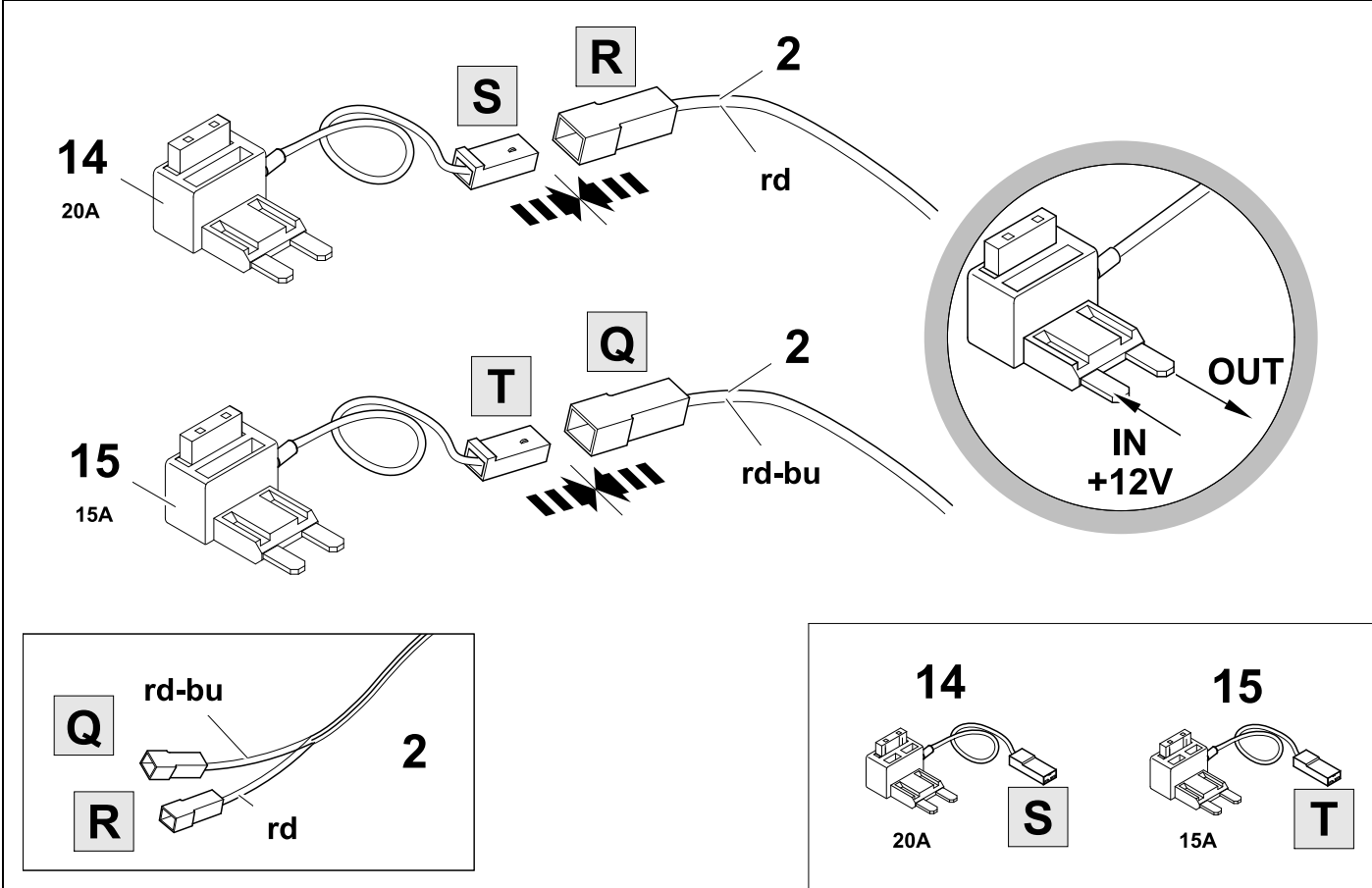

29

👁️ ⇒ 46

OPTION 3

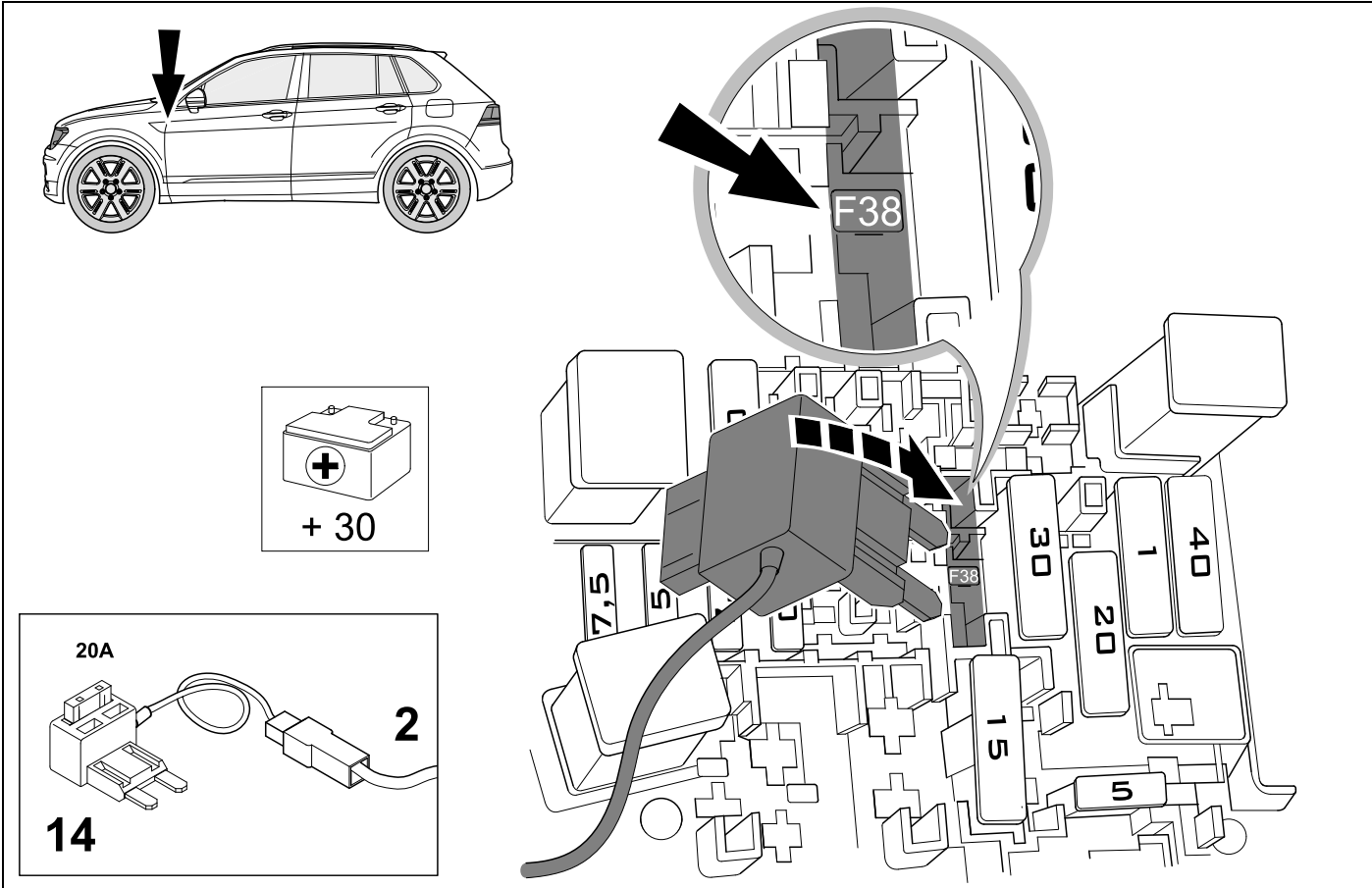

30



46

OPTION 3

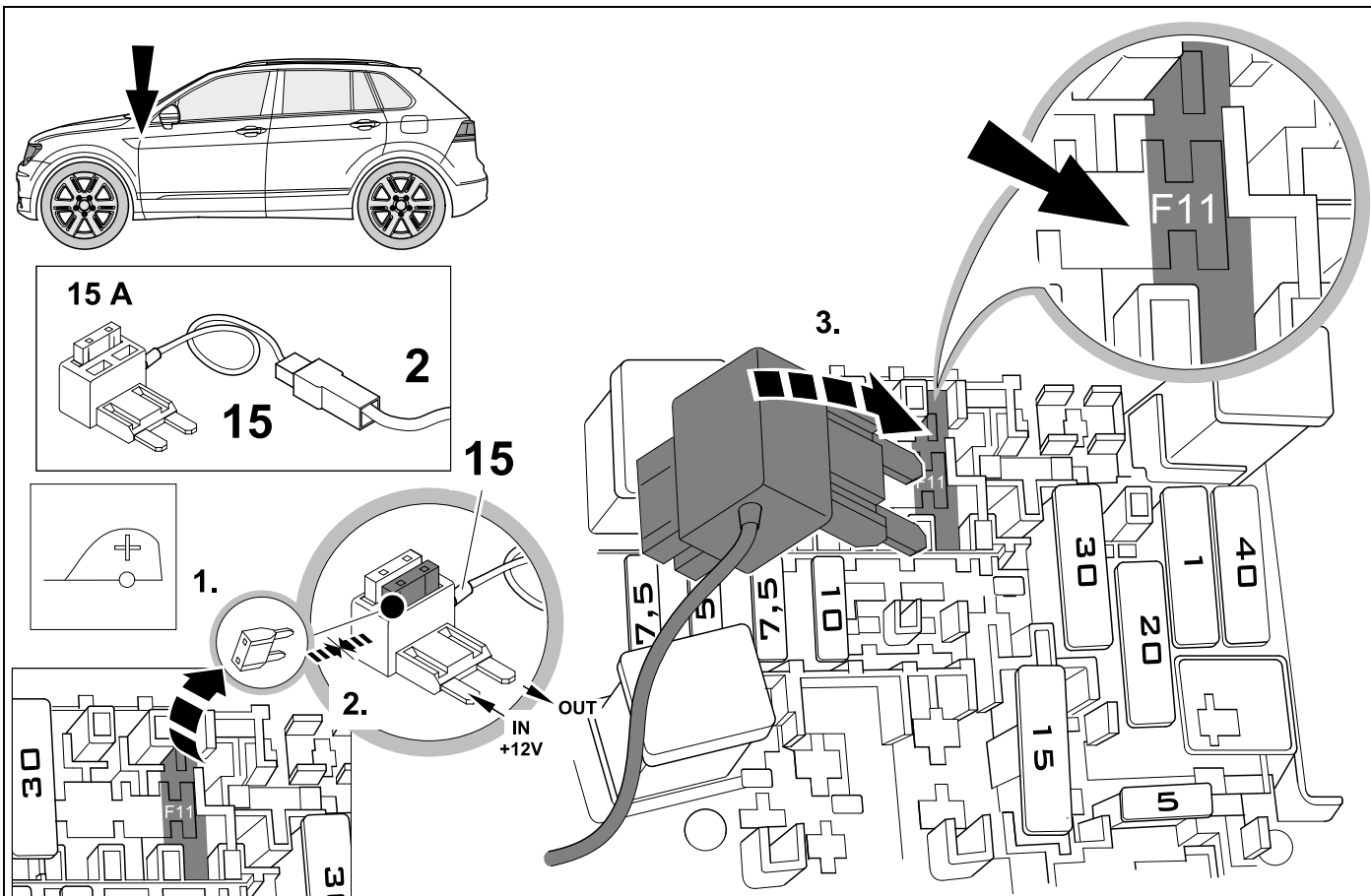

31

OPTION 3

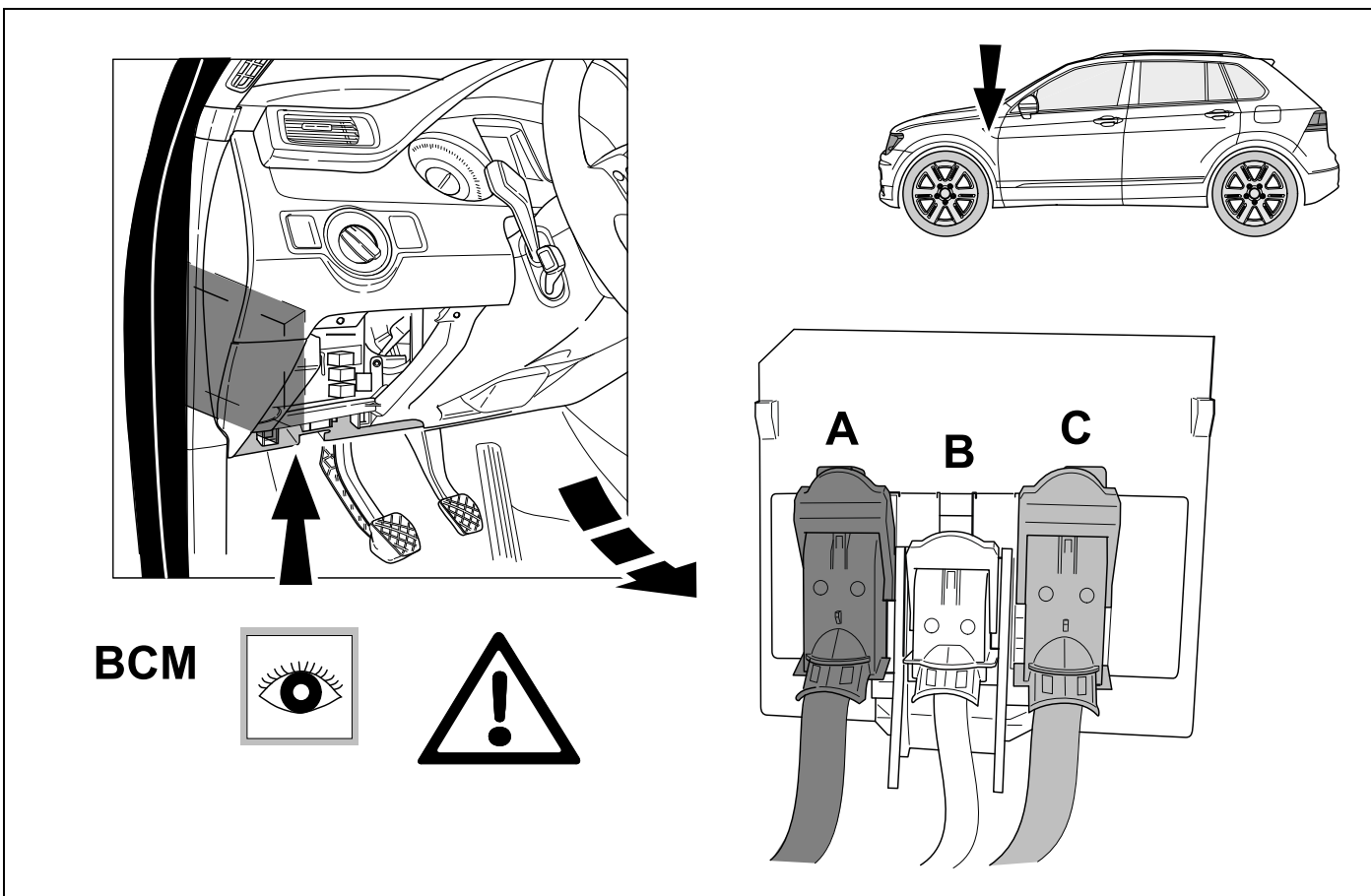

32



9

OPTION 3

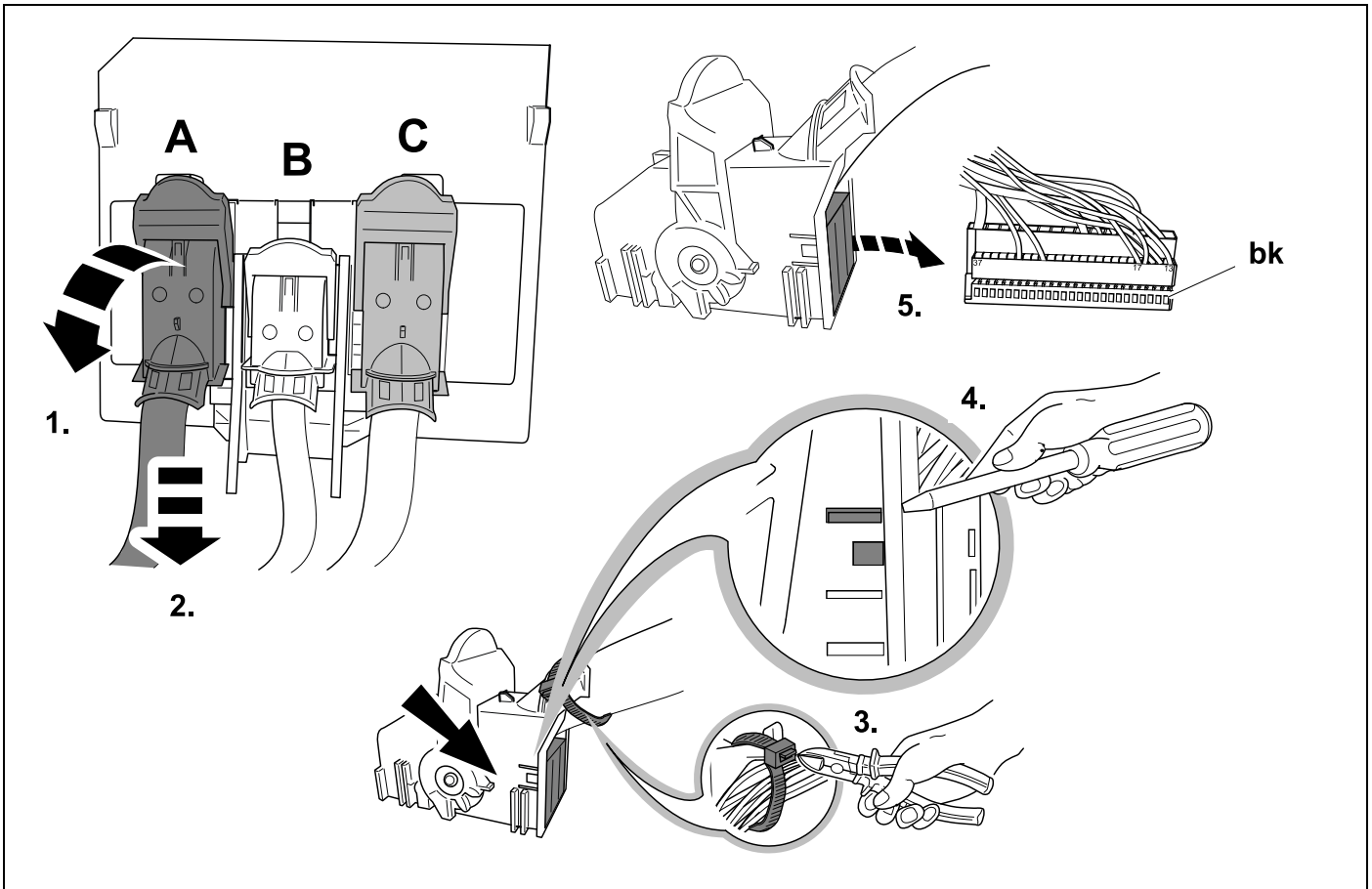

33



9

OPTION 3

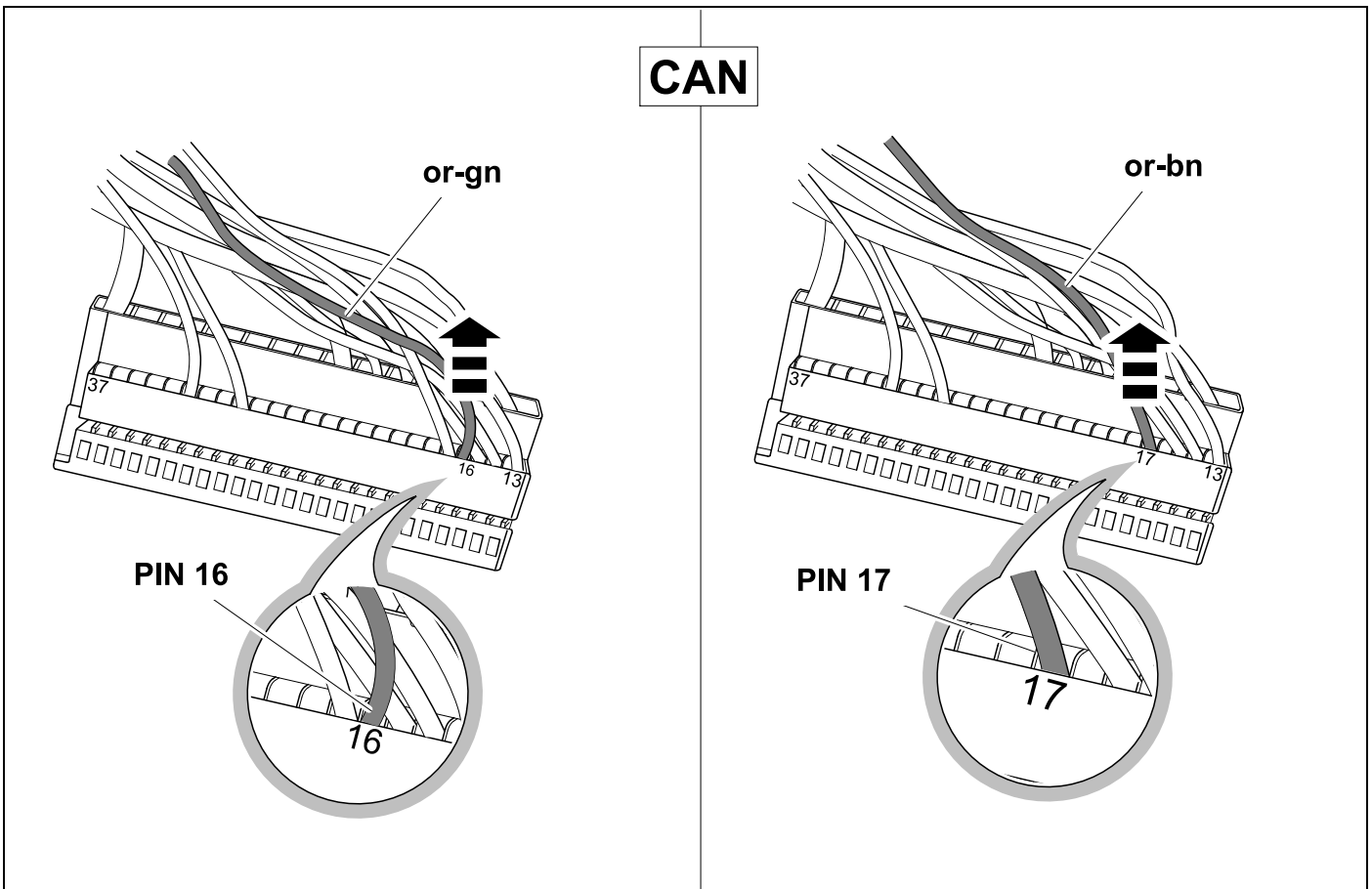

34



9

OPTION 3

CAN

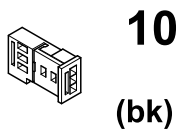
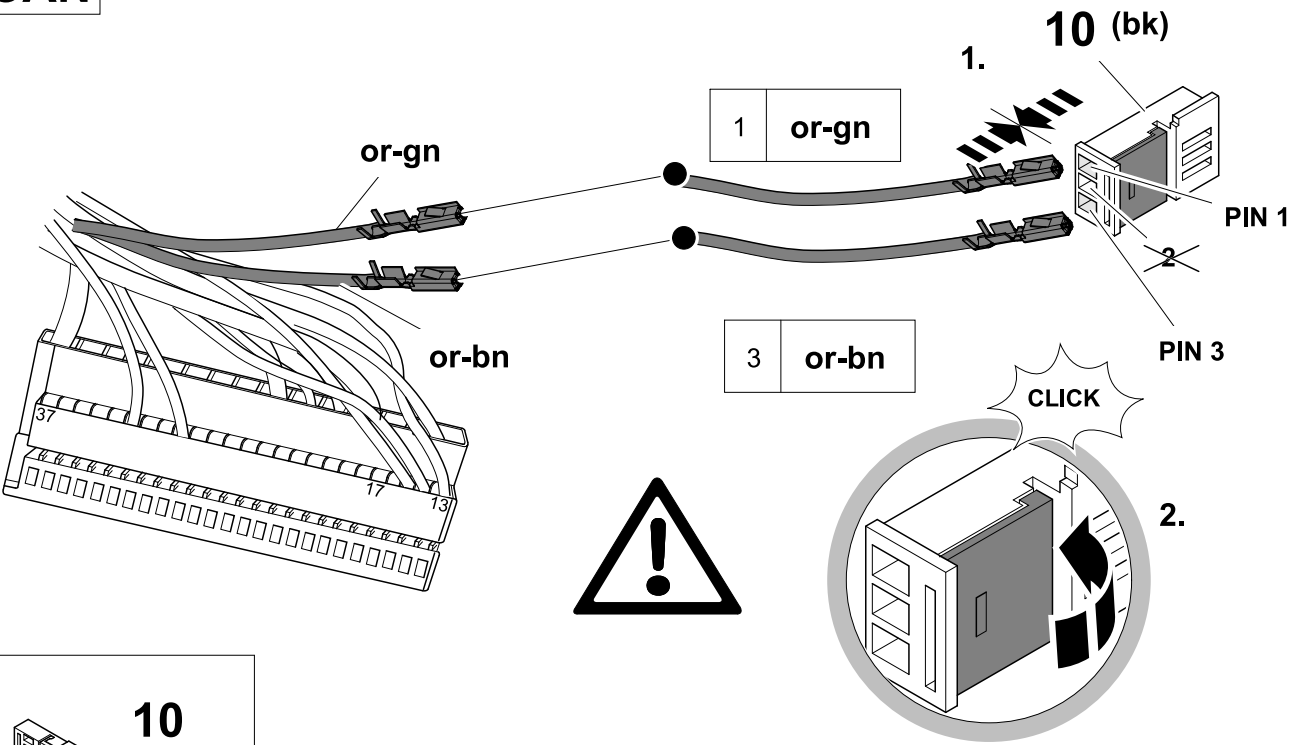

35



9

OPTION 3

CAN

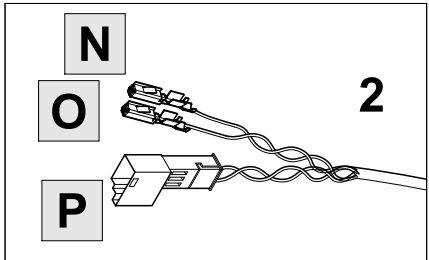
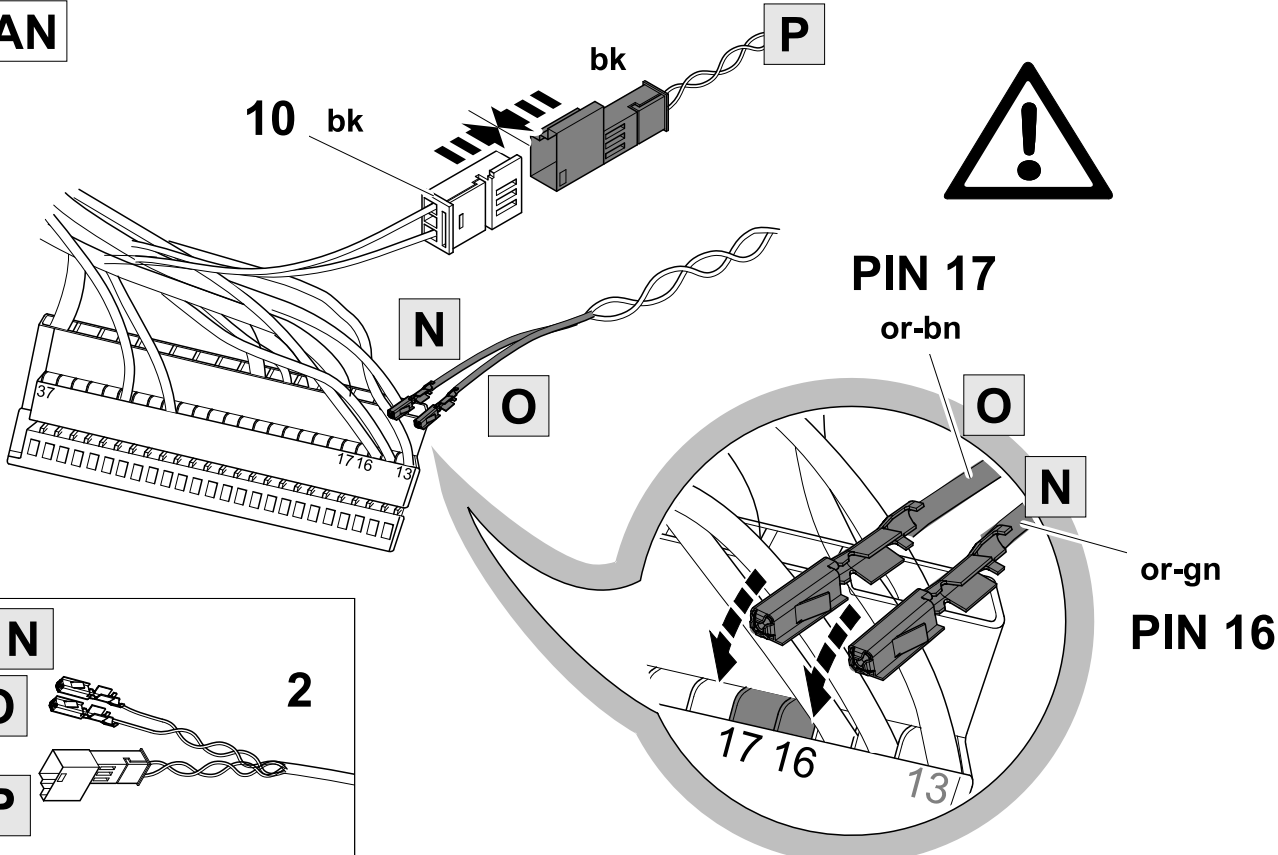

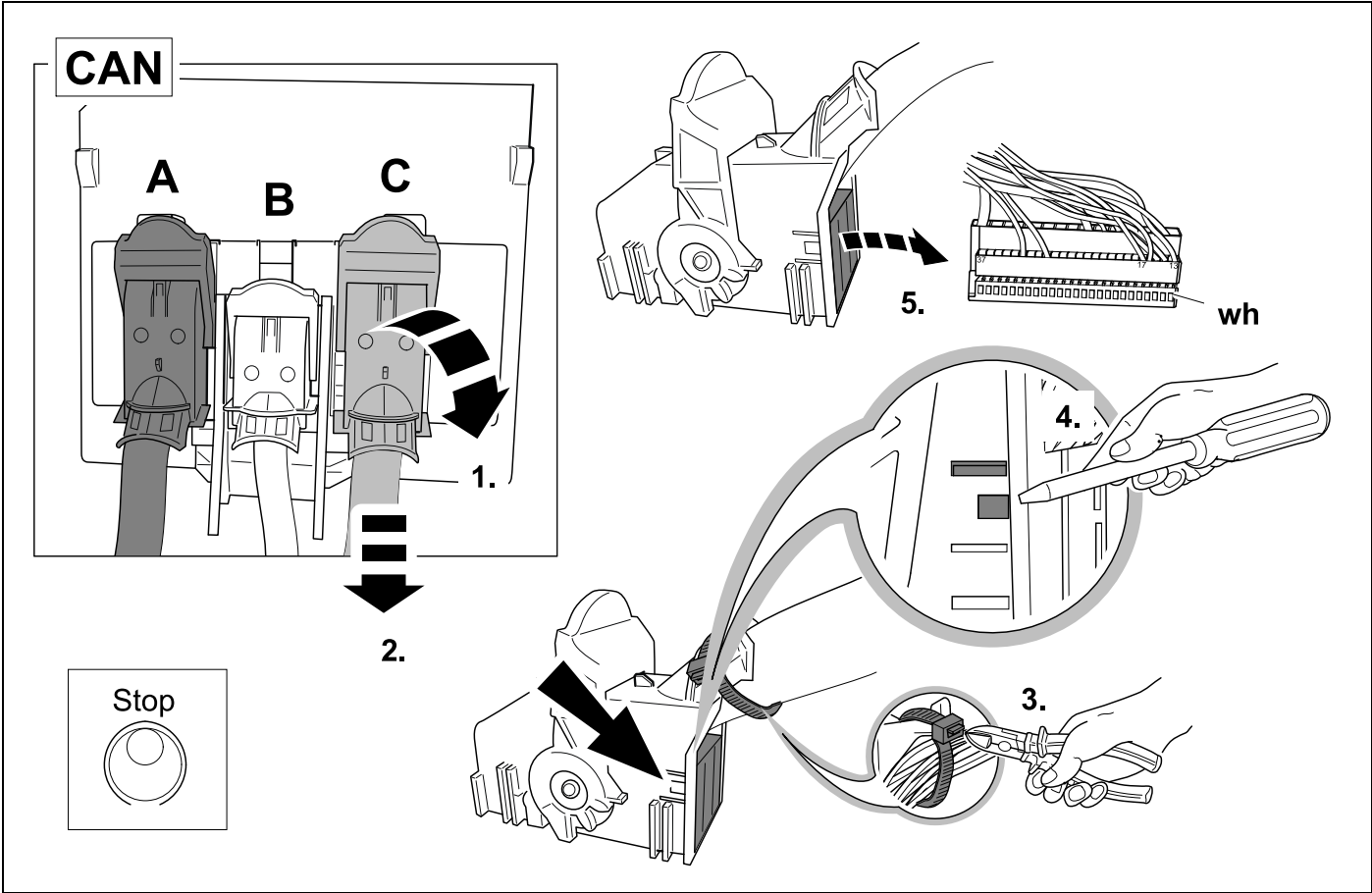
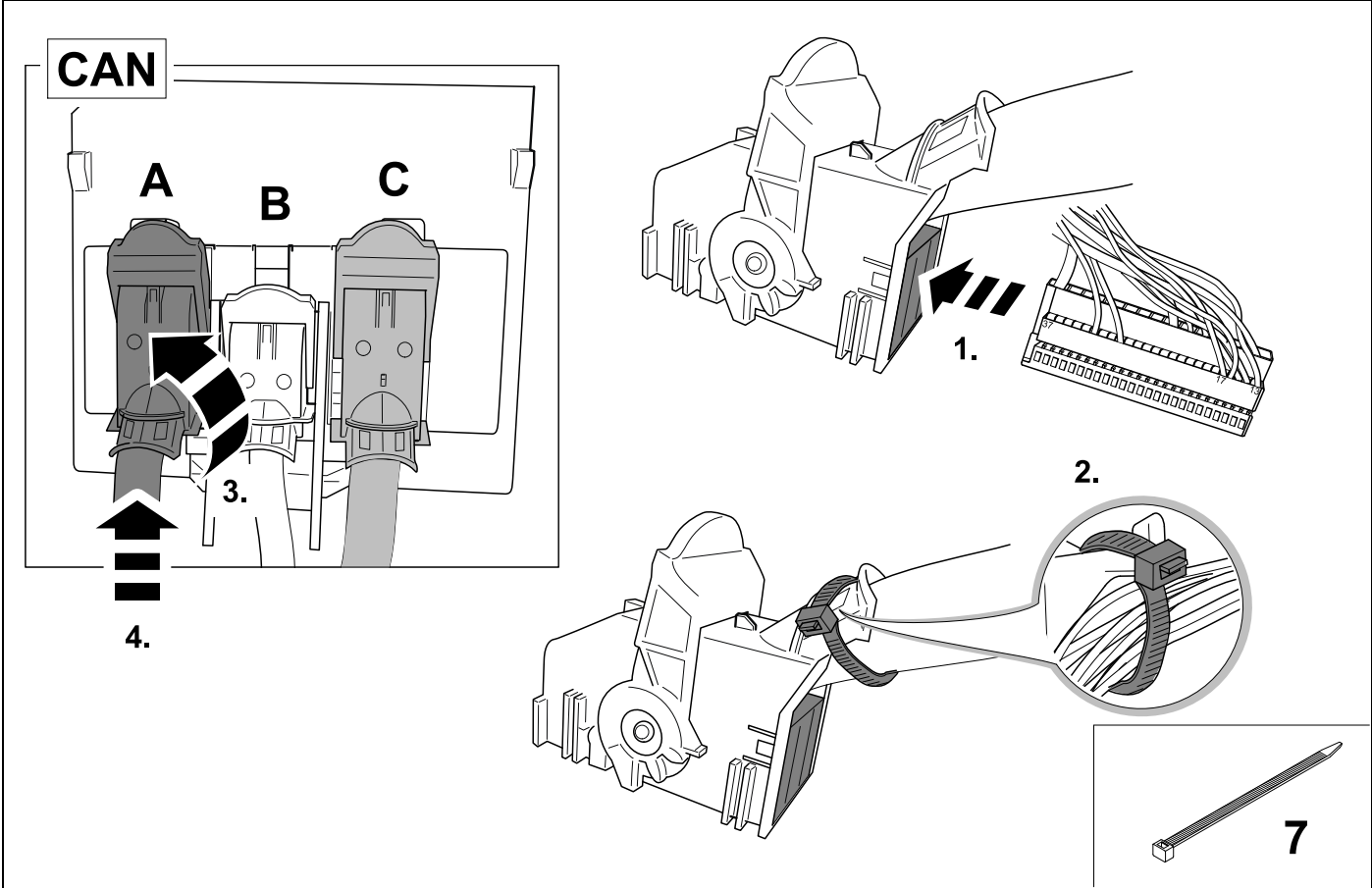

38



9

OPTION 3

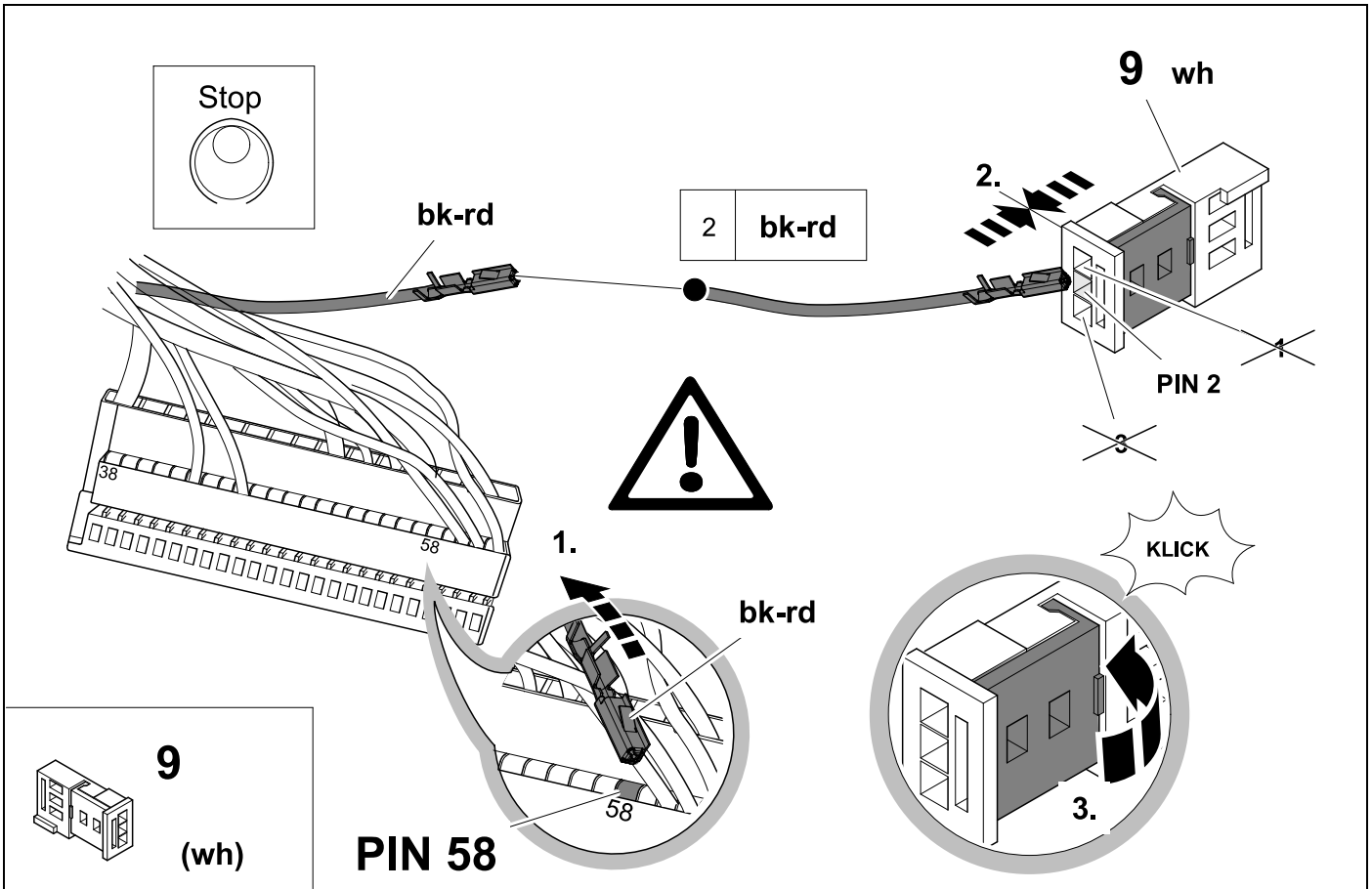

39



9

OPTION 3

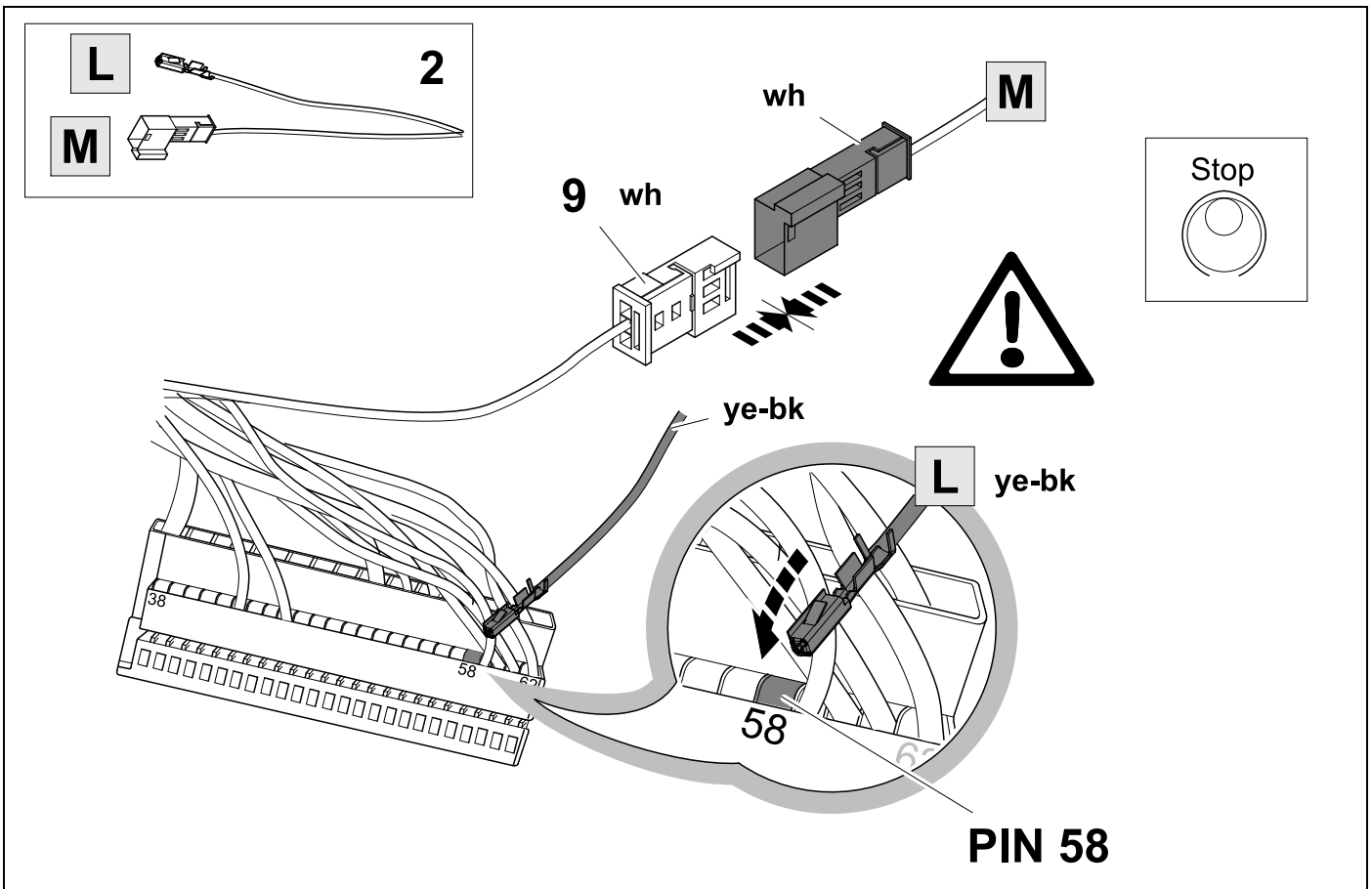

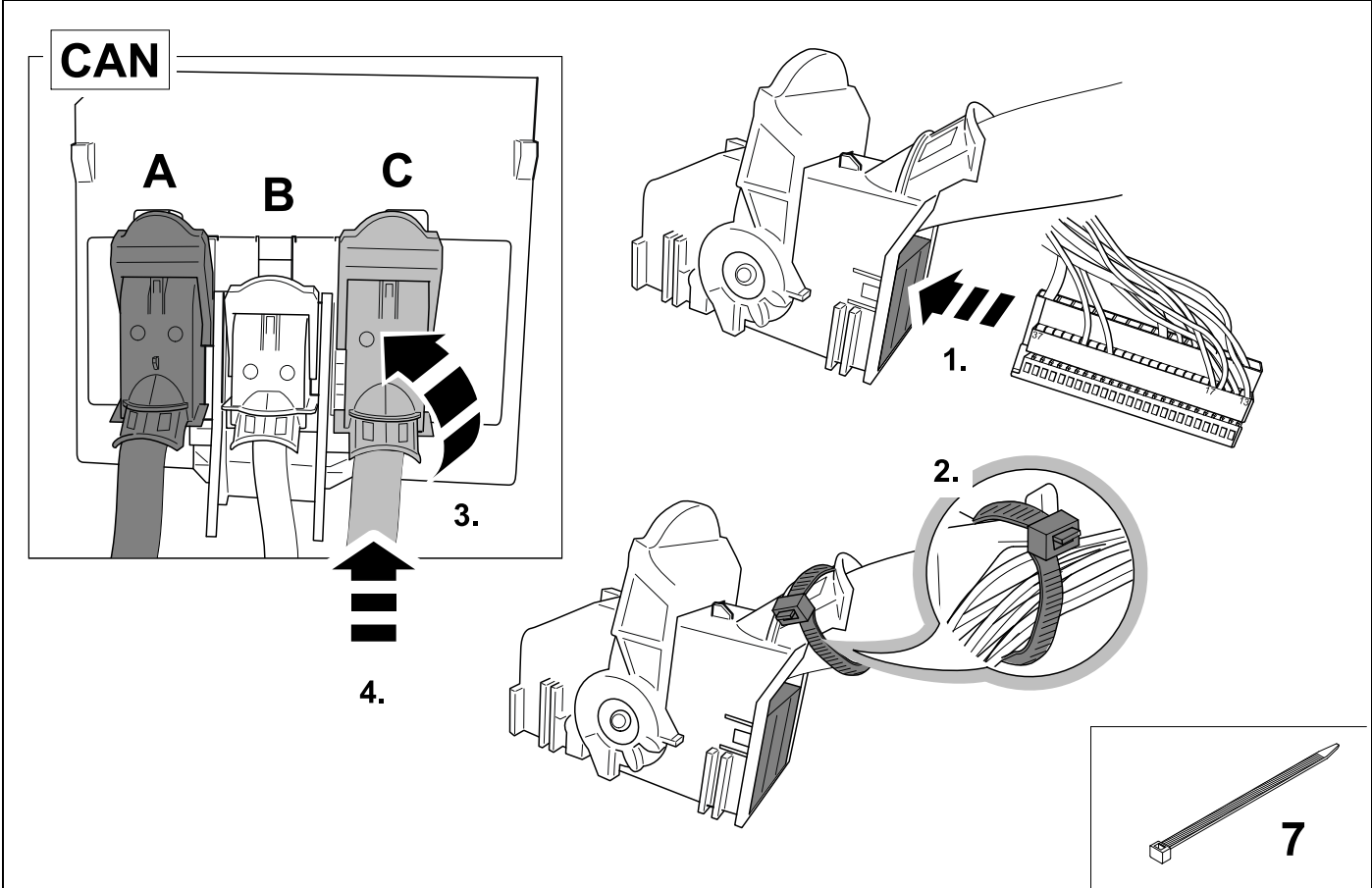

41 OPTIONAL

764159

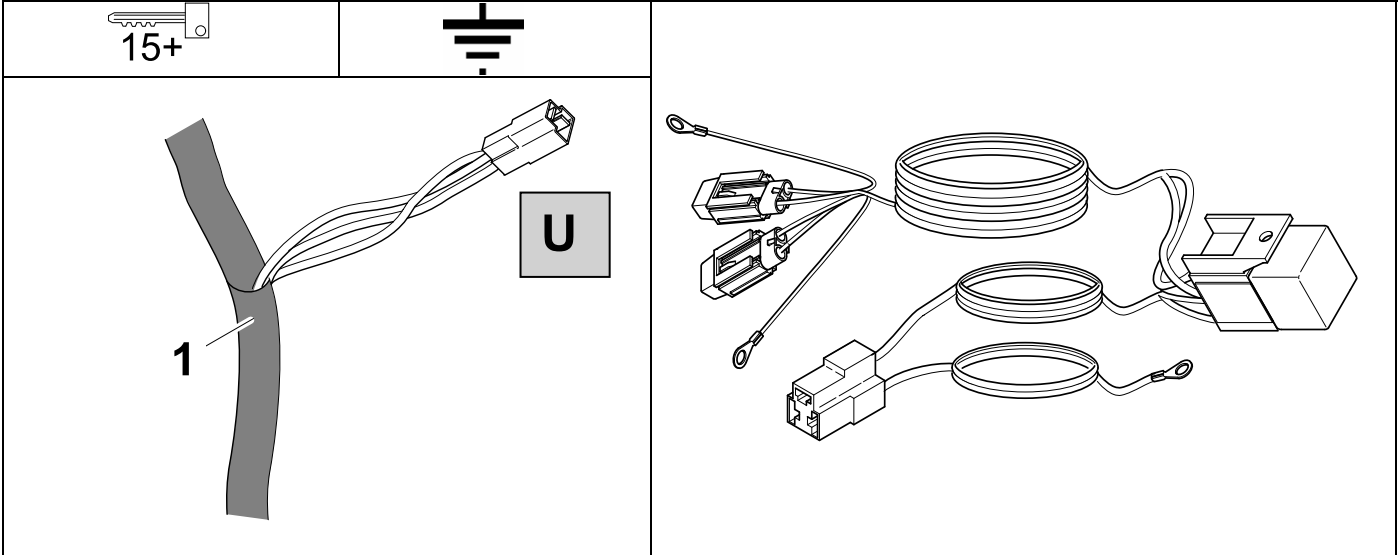

42

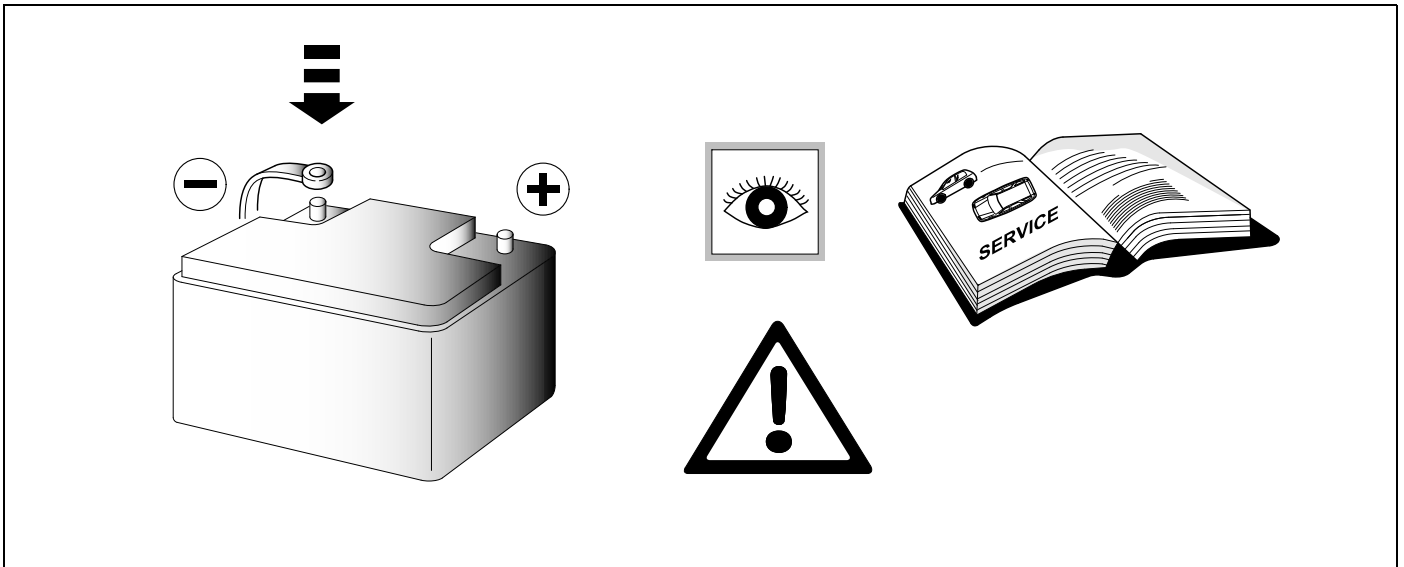

43 CHECK

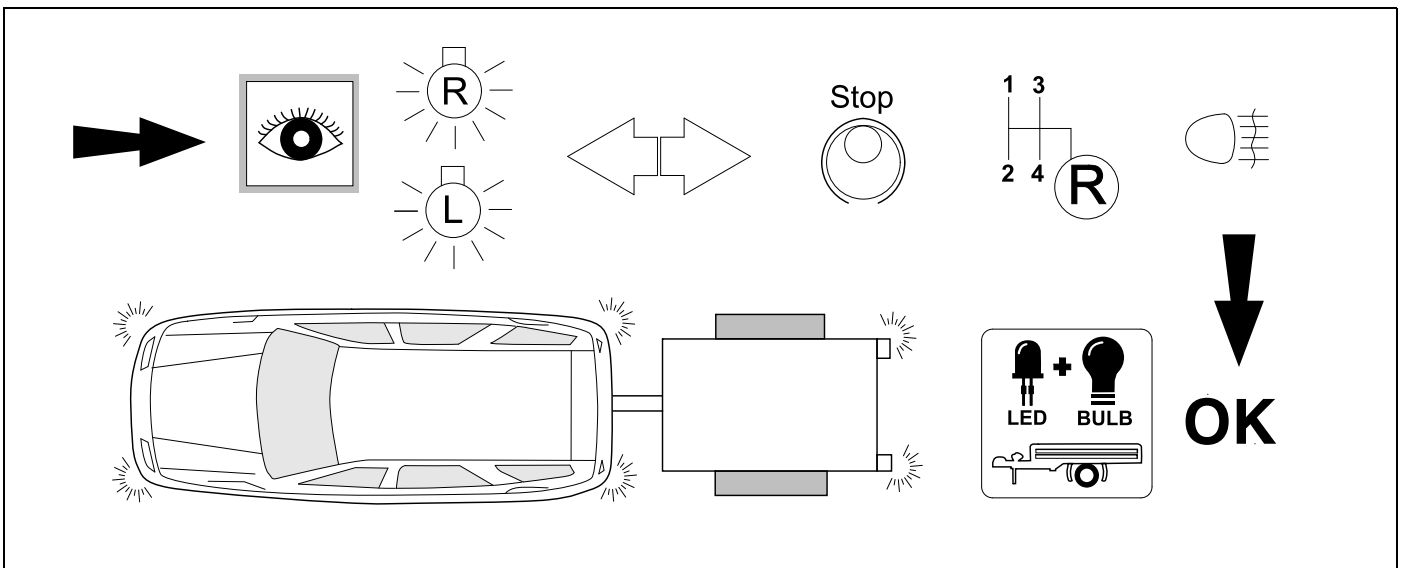

44 OPTIONAL



Trailer Simulator
for 7p and 13p sockets

765069

45 CHECK

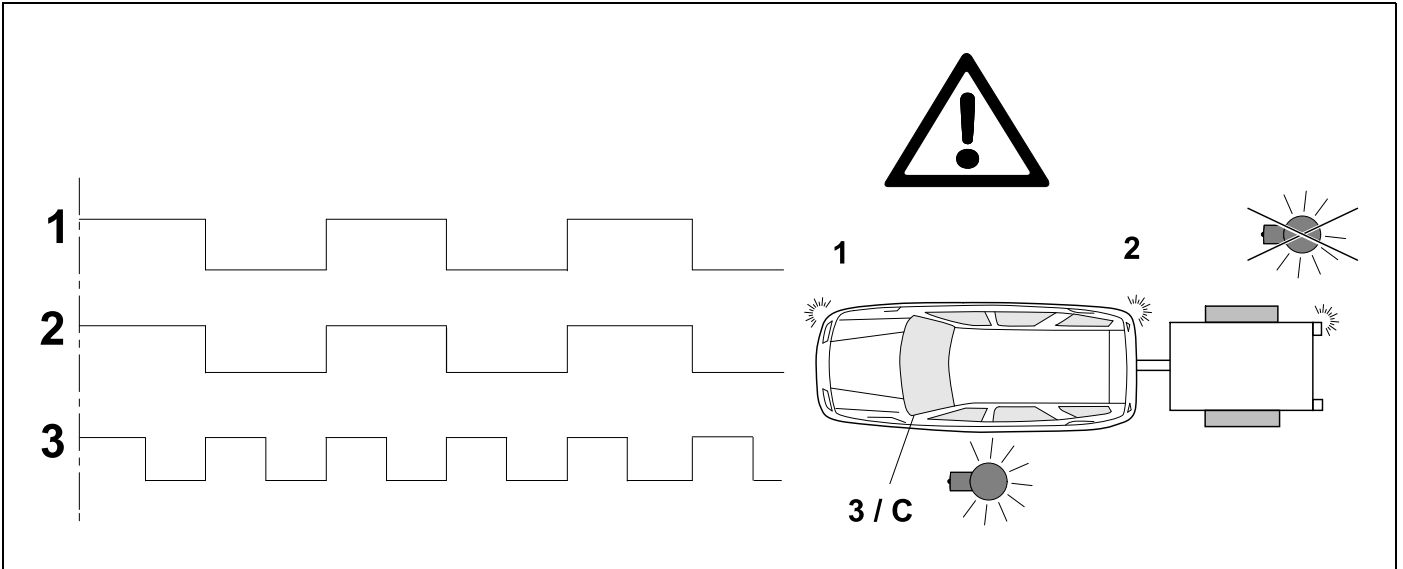

46 Information Service ⇒ 29 + 30

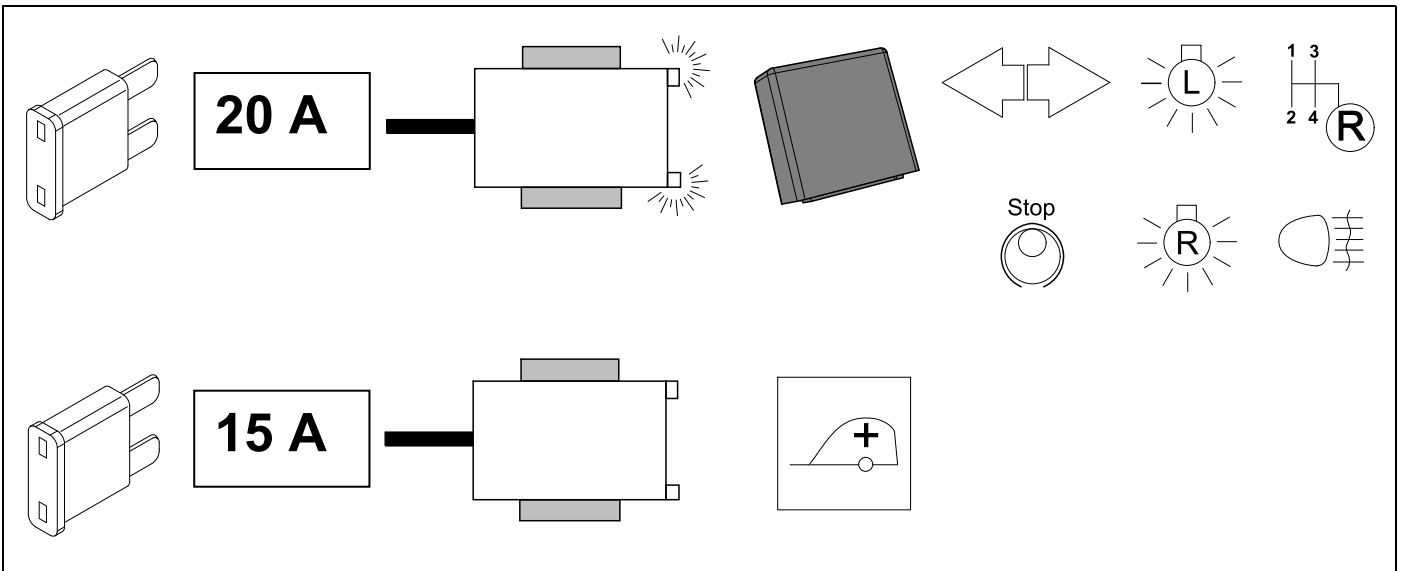

47 OPTIONAL ⇒ **BRiNK**

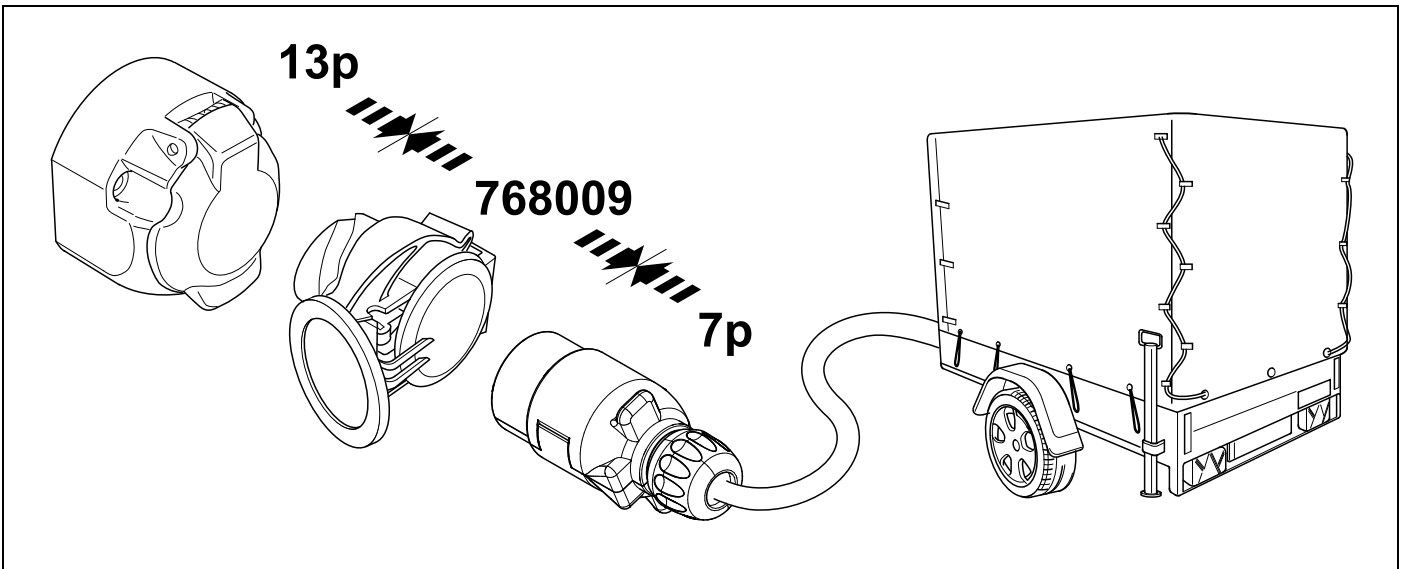

48 PLEASE NOTICE

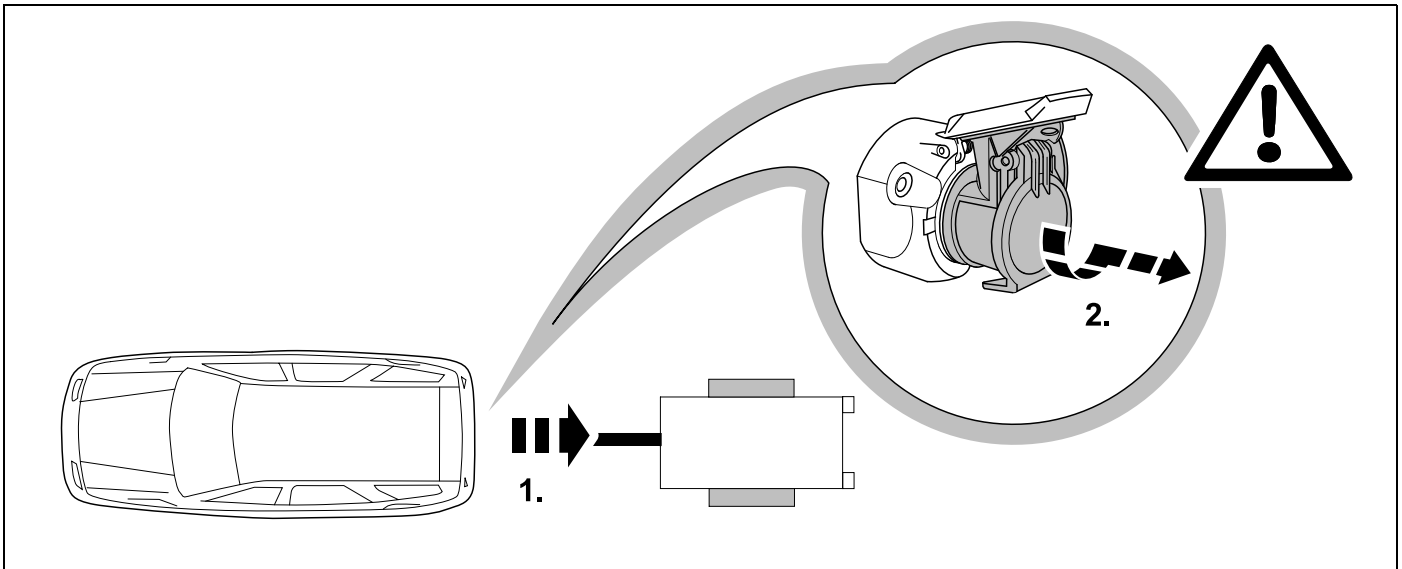

49 PLEASE NOTICE

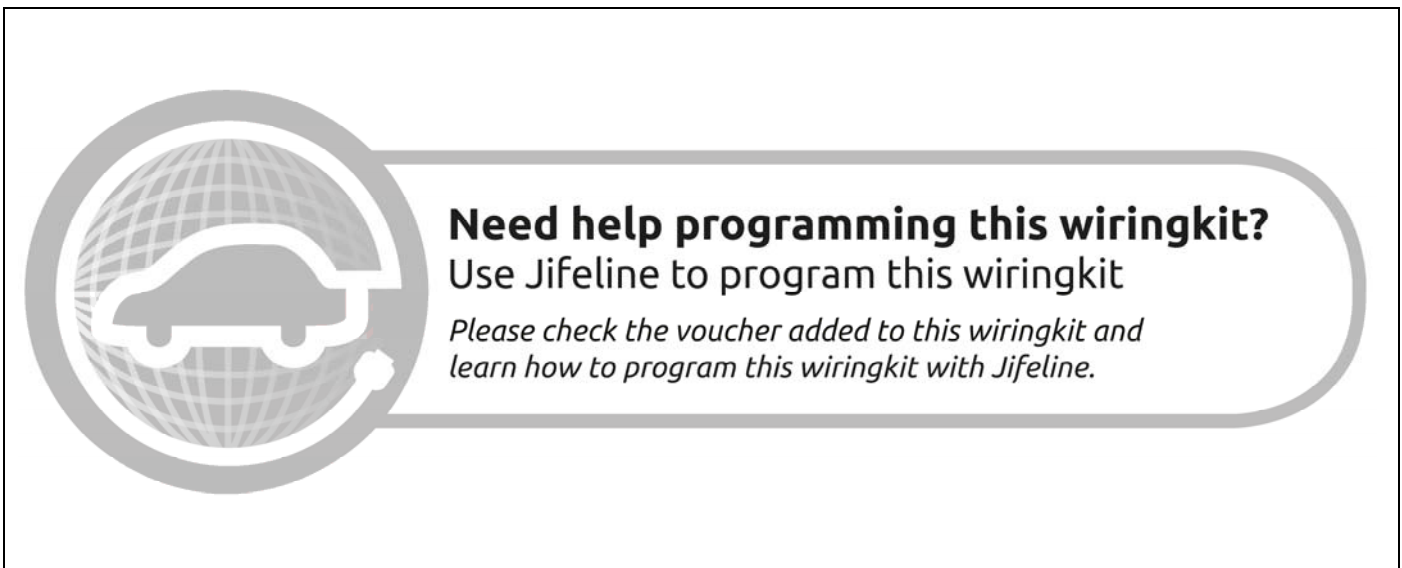

50

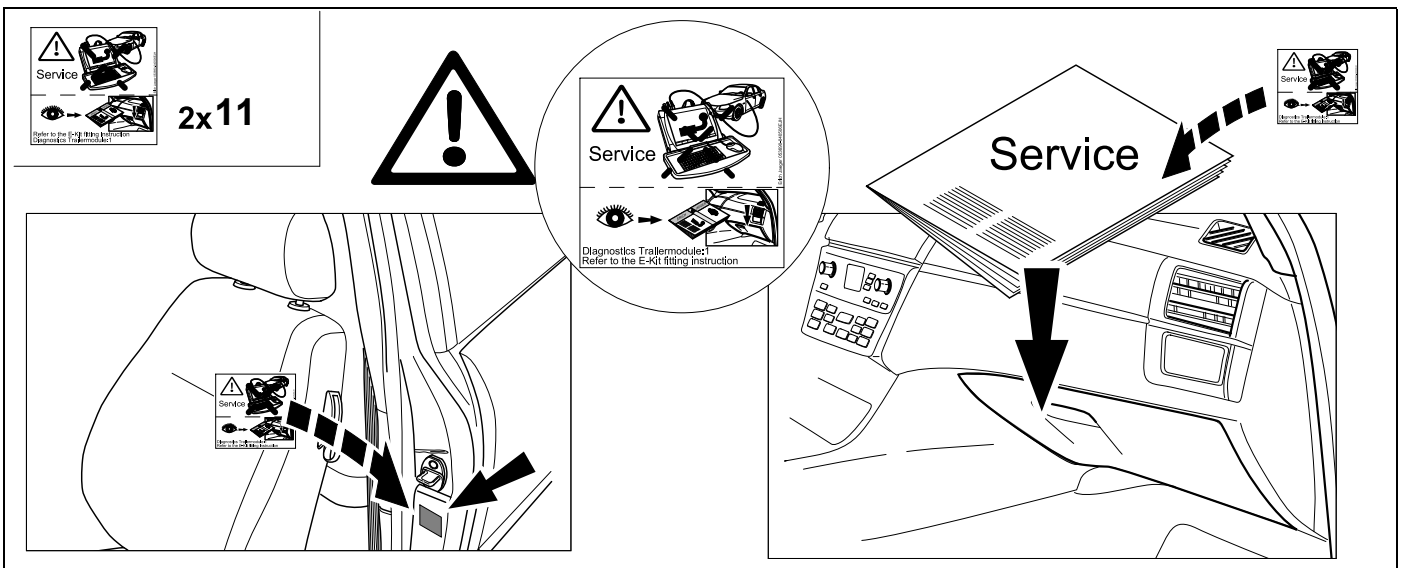

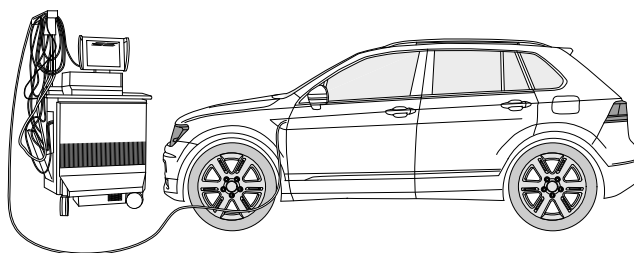

D

GB

Codierung VW Tiguan, -T-Roc mit ODIS / VCDS, bitte beachten:

Der nachfolgend beschriebene Ablauf zur Codierung bzw. Freischaltung auf Anhängerbetrieb dient lediglich zur allgemeinen Orientierung und kann je nach Modell (Motorisierung / Ausstattung) stark variieren. Gegebenenfalls müssen weniger oder noch weitere Steuergeräte angepasst werden.

- **Nach dem Verbinden mit ODIS / VCDS muss in der_19 (Sollverbauliste) das Steuergerät „69 Anhängerfunktion“ auf > codiert gesetzt werden**
- **Codierung EZE_09 (Elektronisches Zentralelektrik-Steuergerät; Login 31347)**
Diagnose / Eigendiagnose / Vernetzungsplan
Eigendiagnose Steuergerät
Codieren; hitch_ecu > installed;
Bei Modellen (MJ 2017 >>) Anpassung > Kanal
-Vernetzung Anhängeranschlussgerät > verbaut
- **Codierung ZKS_46 (Zentralmodul / Komfortsystem)**
trailer monitoring > auf aktiv setzen
trailer control unit > verbaut
- **Codierung_03 (Bremsenelektronik; Login 61378)**
Anpassung > Kanal - Gespannstabilisierung,
Wert auf > aktiviert setzen
- **Codierung SWA_3C (Spurwechselassistent)**
ECU for draw bar > with ECU for draw bar
- **Codierung SCH_17 (Schalttafeleinsatz)**
Trailer > ja
- **Codierung RFK_6C (Rückfahrkamerasystem)**
equipment_ahk > verbaut
- **Codierung STF_74 (Fahrwerkssteuerung)**
Anhänger > verbaut
- **Codierung EPH_76 (Einparkhilfe Steuergerät)**
Anhänger > Anhängervorrichtung manuell abnehmbar
- **Codierung DiS_13 (Distanzregelung Steuergerät)**
Control module for towing sens > verbaut
- **Codierung FFF_A5 (Frontsensorik Steuergerät)**
AAG > coded
- **Codierung HDE_6D (Heckdeckelelektronik Steuergerät)**
Anhänger > verbaut

Wichtiger Hinweis zu Codierung bzw. Freischaltung auf Anhängerbetrieb

Die vorab genannten Einstellungen werden im Bordnetz des Fahrzeuges vorgenommen und lokal abgespeichert. Bei generellen Updates der Fahrzeugsoftware (beispielsweise im Rahmen von Service- oder Instandsetzungsarbeiten) können diese Einstellungen unter Umständen wieder überschrieben und gelöscht werden. In diesem Fall muss die Freischaltung auf Anhängerbetrieb nach dem Update noch einmal lokal aktualisiert werden. Diagnosehinweise in Bezug auf Anhängerbetrieb, die bei Soll-/Ist- Vergleichen mit den im Herstellerwerk hinterlegten Daten auftreten können, liegen ggf. der lokalen Freischaltung zu Grunde.

Coding VW Tiguan, -T-Roc with ODIS / VCDS Please note:

The procedure described below for encoding and enabling the trailer mode only serves for a general orientation and can vary greatly depending on the model (motorisation / equipment). If necessary less or further control units will have to be adapted.

- **After connecting to ODIS / VCDS, the "69 trailer function" controller has to be set to encoded in the _19 target installation list.**
- **Coding EZE_09 (electronic central electric controller; Login 31347)**
Diagnosis / Networking plan / Controller self-diagnosis
encode hitch_ecu > installed
Vehicles from (MJ 2017>>) adjustment > channel
-integration trailer control unit > installed
- **Coding ZKS_46 (Central module convenience system)**
trailer monitoring > put on active trailer control unit > installed
- **Coding_03 (Brake Electronics; Login 61378)**
Adjustment > channel - trailer stabilization,
change value to > active
- **Encoding SWA_3C (Lane Change Assist)**
ECU for draw bar > with ECU for draw bar
- **Encoding SCH_17 (Dash panel insert)**
Trailer > yes
- **Encoding RFK_6C (reverse camera system)**
equipment_ahk > installed
- **Encoding STF_74 (chassis control system)**
Trailer > installed
- **Encoding EPH_76 (PDC controller)**
Trailer > trailer device can be removed manually
- **Encoding DiS_13 (controler distance control)**
Control module for towing sens > installed
- **Encoding FFF_A5 (front sensor system controller)**
AAG > coded
- **Encoding HDE_6D (boot lid electronics controller)**
Trailer > installed

Important note on encoding and activating in trailer mode

The aforementioned settings are carried out in the vehicle's electrical system and saved locally. During general updates for the vehicle software (for example, within the scope of service or repair work) the settings may be overwritten and deleted under certain circumstances. At this case, the trailer mode activation has to be updated again locally after the update. Diagnostic information relating to the trailer mode that may appear during variance comparisons with the data saved in the manufacturer's works, may form the basis of the local activation

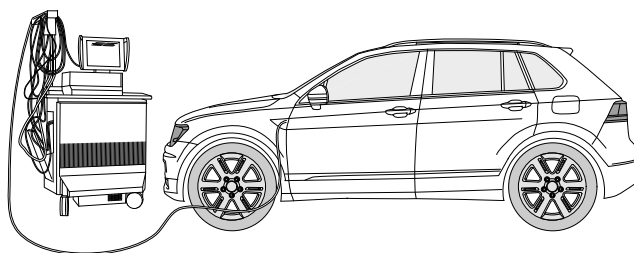

F

Codage VW Tiguan, -T-Roc avec ODIS / VCDS**Attention:**

La procédure de codage ou d'activation du fonctionnement avec remorque décrite cidessous sert uniquement d'orientation générale et peut varier fortement d'un modèle a l'autre (motorisation l'équipement). Le cas échéant, il peut s'avérer nécessaire d'adapter moins ou d'autres dispositifs de commande.

- **Une fois la connexion avec ODIS établie, mettre l'appareil de commande «69 fonctionnement avec remorquen sur «codén dans _19 la liste d'assemblage théorique**
- **Codage EZE_09 (appareil de commande de la centrale électrique électronique; Login 31347)**
Diagnostic / Pian de mise en réseau / Autodiagnostic
appareil de commande, codage hitch_ecu > installed;
Véhicules depuis (MJ 2017 >>) Ajustement > canal
- intégration de l'unité de remorque > installée
- **Codage ZKS_46 (Système de commodité de module Central)**
trailer monitoring > mettre actif trailer control unit
> monté
- **Codage_03 (Electronique de freinage; Login 61378)**
Ajustement > canal – stabilisation de la remorque,
valeur sur > activé
- **Codage SWA_3C (l'aide au changement de voie)**
ECU for draw bar > with ECU for draw bar
- **Codage SCH_17 (tableau de commande insert)**
Remorque > oui
- **Codage RFK_6C (Système de caméra de recul)**
equipment_ahk > monté
- **Codage STF_74 (Système de commande de chassis)**
Remorque > monté
- **Codage EPH_76 (aide au stationnement appareil de commande)**
Remorque > dispositif de remorque; démontable a la
main
- **Codage DiS_13 (régulateur de distance appareil de commande)**
Control module for towing sens > monté
- **Codierung FFF_A5 (capteurs avant appareil de commande)**
AAG > coded
- **Codage HDE_6D (appareil de commande de l'électronique du hayon électrique)**
Remorque > monté

Remarque importante sur le codage ou sur l'activation du fonctionnement avec remorque

Les réglages mentionnés ci-dessus sont effectués dans le réseau de bord du véhicule et sauvegardés localement. Lors des mises a jour générales du logiciel du véhicule (par exemple dans le cadre de travaux de maintenance ou de réparation), ces réglages peuvent dans certaines circonstances être écrasés et supprimés. Dans ce cas, l'activation du fonctionnement avec remorque doit être a nouveau actualisée localement après la mise a jour. L'activation locale peut le cas échéant être causées par des remarques de diagnostic relatives au fonctionnement avec remorque susceptibles d'être générées lors de la comparaison entre valeurs théoriques/valeurs réelles effectuée avec les valeurs conservées dans l'usine du constructeur..

I

Codifica VW Tiguan, -T-Roc con ODIS / VCDS**Attenzione:**

Esercizio rimorchio descritto qui di seguito serve esclusivamente come orientamento generale e può variare radicalmente a seconda del modello (motorizzazione / dotazione). È possibile che meno o altre centraline debbano essere adeguate.

- **Dopo la connessione con ODIS / VCDS, nella lista _19 d'installazione nominale la centralina 69 Funzione rimorchio" deve essere codificata.**
- **Codifica EZE_09 (centralina del sistema elettrico centrale elettronico; Login 31347)**
Schema di collegamento in rete / Autodiagnosi / centralina / codifica > hitch_ecu > installed
Veicolo da (MJ 2017>>) Regolazione ->canale-integrazione centralina rimorchio ->installata
- **Codifica ZKS_46 (Sistema di convenienza di modulo centrale)**
trailer monitoring > attivare / trailer control unit > installato
- **Codifica _03 (Frenatura elettronica; Login 61378)**
Regolazione > canale – stabilizzazione rimorchio,
cambio valore su > attivo
- **Codifica SWA_3C (Cambio corsia Assist)**
ECU for draw bar > with ECU for draw bar
- **Codifica SCH_17 (Inserto cruscotto)**
Trailer > si
- **Codifica RFK_6C (sistema di telecamere retromarcia)**
equipment_ahk > installato
- **Codifica STF_74 (sistema di controllo del telaio)**
Rimorchio > installato
- **Codifica EPH_76 (centralina ausilio di parcheggio)**
Rimorchio > dispositivo rimorchio rimovibile manualmente
- **Codifica DiS_13 (centralina regolazione distanza)**
Control module for towing sens > installato
- **Codifica FFF_A5 (centralina sensori frontali)**
AAG > coded
- **Codifica HDE_6D (centralina sistema elettronico coperchio portabagagli)**
Rimorchio > installato

Avvertenza importante per la codifica_ o. l'attivazione per funzionamento con rimorchio

Le impostazioni indicate in precedenza vengono effettuate nella rete di bordo del veicolo memorizzate localmente. Nel caso di update generalidei software del veicolo (ad esempio nell'ambito dei lavori di assistenza e messa a punto), in part1colan circostanze è possibile sovrascrivere e cancellare nuovamente queste impostazioni. In questo caso dopo l'update deve essere nuovamente aggiornata localmente l'attivazione per funzionamento con rimorchio. Le avvertenze di diagnosi in riferimento al funzionamento con rimorchio , generate durante una comparazione dei valori nominali/effettivi con i dati inseriti in fabbrica dal costruttore , potrebbero dipendere dall'attivazione locale

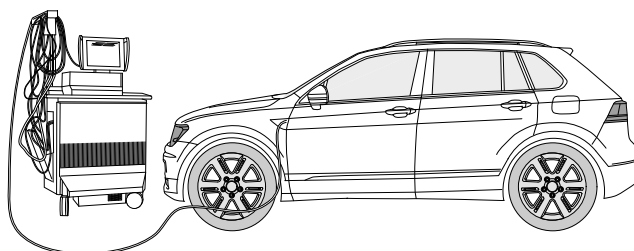

E

NL

Codificación de VW Tiguan, -T-Roc noc ODIS / VCDS Por favor, tener en cuenta

El proceso descrito codificación para la codificación y/o habilitación para el servicio con remolque sólo sirve para una orientación general y puede variar considerablemente dependiendo del modelo (motorización/equipamiento). En caso dado puede que tengan que adaptarse menos u otros reguladores.

- **Después de haber establecido la conexión con ODIS / VCDS se deberá ajustar el controlador 69 función de remolque" en _19 la lista de dispositivos a codificar**
- **Codificación EZE_09 (controlador del sistema eléctrico central electrónico; Login 31347)**
Esquema de interconexión / Autodiagnos del controlador
Codificación hitch_ecu > installed;
Vehiculos desde (MJ 2017 >>) Adaptación -> canal
- integración de la unidad de remolque -> instalada
- **Codificación ZKS_46 (Sistema de confort de módulo central)**
trailer monitoring > poner en activo trailer control unit
> montado
- **Codificación _03 (Frenos Electrónica; Login 61378)**
Adaptación > canal - estabilización del remolque,
valor en > activado
- Codificación SWA_3C (asistente de cambio de caml)**
ECU for draw bar > with ECU for draw bar
- Codificación SCH_17 (Cuadro de instrumentos)**
Trailer > si
- **Codificación RFK_6C (sistema de cámara de reversa)**
equipment_ahk > montado
- Codificación STF_74 (sistema de control de chasis)**
Remolque > montado
- **Codificación EPH_76 (controlador del sistema de ayuda al aparcamiento)**
desmontable a mano
- Codificación DiS_13 (controlador del sistema de regulación de distancia)**
Control module for towing sens > montado
- Codificación FFF_A5 (controlador del sistema de sensores frontales)**
AAG > coded
- **Codificación HDE_6D (controlador del sistema electrónico de la puerta del maletero)**
Remolque > montado

Nota importante sobre la codificación y/o habilitación del modo remolque

Los ajustes anteriormente mencionados se llevan a cabo en el sistema eléctrico de a bordo y se guardan de forma local. Al realizar actualizaciones generales de software del vehículo (por ejemplo con motivo de trabajos de mantenimiento o reparación) es posible que estos ajustes se vuelvan a borrar y sobrescribir. En tal caso se deberá volver a actualizar la habilitación del modo remolque de forma local después de la actualización. Los avisos de diagnosis relacionados con el modo remolque, que puedan aparecer en caso de comparación de datos teóricos/reales con los datos depositados en la fábrica, se pueden deber a la habilitación local

Codering VW Tiguan, -T-Roc met ODIS / VCDS Let op a.u.b.:

Het hieronder omschreven proces voor de codering van de aanhangwagen functie dient uitsluitend ter algemene oriëntatie en kan afhankelijk van model (motorisering / uitvoering) sterk variëren. Indien nodig, moeten mindere of andere besturingsapparaten worden aangepast.

- **Na aansluiting met het on board diagnostisch systeem ODIS / VCDS moet in de _19 installatie lijst, de regeleenheid '69- aanhangwagenfunctie' worden ingesteld als zijnde 'gecodeerd'.**
- **Codering EZE_09 (Aansturingsapparaat voor .de elektronische centrale elektriciteitsvoorzienng; Login 31347)**
Diagnose Aansluitingsdiagram / Zelfdiagnose van de controller / Coderen hitch_ecu > installed
Voertuigen vanaf (MY 2017>>) Wijziging – kanaal
Integreren trailer controle unit – geïnstalleerd
- **Codering ZKS_46 (Centrale module gemak systeem)**
trailer monitoring > gezet op actief trailer control unit > geïnstalleerd
- **Codering _03 (Rem electronica; Login 61378)**
Wijziging > Kanaal – trailer stabilisatie, wijzig waarde naar > actief
- Codering SWA_3C (Rijstrookwisselhelp)**
ECU for draw bar > with ECU for draw bar
- Codering SCH_17 (Inzetstuk Dash)**
Trailer > ja
- **Codering RFK_6C (achteruitrijcamera systeem)**
equipment_ahk > geïnstalleerd
- Codering STF_74 (chassis controlesysteem)**
aanhanger > geïnstalleerd
- **Codering EPH_76 (controller parkeersysteem)**
aanhanger > aanhangerunit handmatig loste koppelen
- Codering DiS_13 (controller automatische afstandscontrole)**
Control module for towing sens > geïnstalleerd
- Codering FFF_A5 (controller sensoren voorzijde)**
AAG > coded
- **Codering HDE_6D (controller achterklepelectronica)**
Aanhanger > geïnstalleerd

Belangrijke aanwijzing voor het coderen, dan wel deblokken van het aanhangerbesturingsysteem

De eerder genoemde instellingen worden uitgevoerd op de boordcomputer van uw voertuig en ze worden lokaal opgeslagen. Het is echter mogelijk dat bij een algemene update van uw voertuigsoftware (bijvoorbeeld in het kader van een servicebeurt Of tijdens herstelwerkzaamheden) uw instellingen onder bepaalde omstandigheden worden overgeschreven dan wel gewist. In dat geval moet de deblokkenng van het aanhangerbesturingsysteem na de update nog een keer lokaal worden geactualiseerd. Eventueel kunnen er diagnostische instructies/meldingen ten aanzien van het aanhangerbesturingsysteem worden gegenereerd door het feit dat er lokaal wordt gedeblokkeerd - die situatie kan zich voordoen wanneer de fabrieksinstellingen worden gebruikt in vergelijkingen tussen een actuele en een gewenste situatie

HELLA
GUTMANN
DIAGNOSTICS
SOLUTIONS

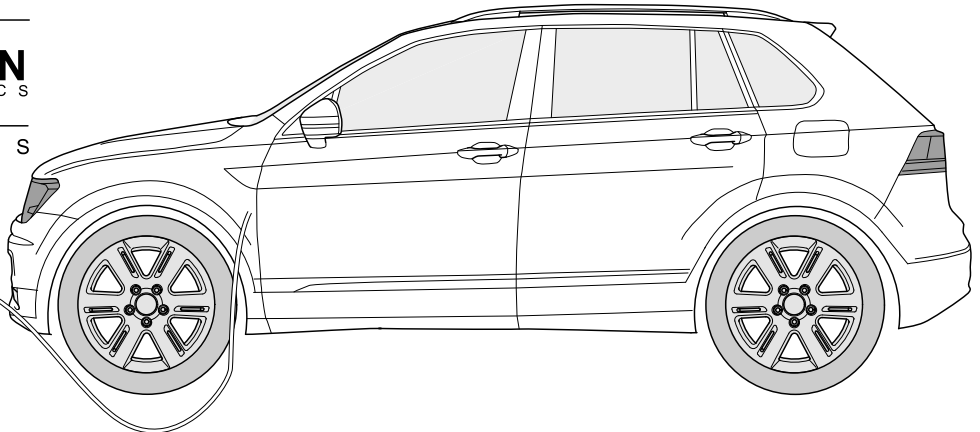
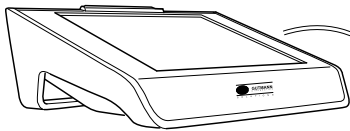
**D**

Die Aktivierung der Anhängerfunktionen muss wie folgt durchgeführt werden:

1. Fahrzeugauswahl
2. Zu Diagnose – Codierung wechseln
3. Anhängerkupplung de-/aktivieren
4. Diagnose Interface Bus auswählen
5. Anleitung folgen

Fahrzeuge mit Assistenzsystemen

6. AHK an Assistenzsysteme anpassen ausführen
7. Anleitung folgen
8. Diagnose
9. Fehlerspeicher auslesen, ggf. löschen
10. Fertig

GB

The activation of the trailer functions must be performed:

1. Vehicle selection
2. switch to diagnostics - coding
3. Deactive/aktive trailer coupling
4. Select diagnostic interface Bus
5. Follow instructions

Vehicle with assistance systems

6. perform adaptation of trailer coupling on assistance systems
7. Follow instructions
8. Diagnostics
9. Read out error memory, delete if necessary
10. Done

F

Pour activer l'attelage, procéder de la façon suivante:

1. Choix véhicule
2. Aller dans le diagnostic - codage
3. Activer/désactiver le diagnostic
4. Sélectionner le BUS d'interface de diagnostic
5. Suivre les instructions

Véhicules avec systèmes d'aide

6. Effectuer une adaptation d'attelage aux systèmes d'aide
7. Suivre les instructions
8. Diagnostic
9. Lire la mémoire de défaut et effacer les codes d'erreur éventuellement mémorisés
10. Terminé

I

Per attivare le funzioni del rimorchio, procedere nel modo seguente:

1. Scelta vettura
2. Passare alla Diagnosi - Codifica
3. Attivare / disattivare il gancio di traino
4. Selezionare il interfaccia di diagnosi
5. Seguire le istruzioni

Veicoli noc suster di assistenza

6. adattare i suster installati
7. Seguire le istruzioni
8. Diagnosi
9. Leggere la memoria guasti e cancellare, se necessario
10. Fertig

E

La activación de las funciones de remolque debe la siguiente manera:

1. Selección de vehículo
2. Cambiar a diagnosis - Codificación
3. Desactivar/ activar acoplamiento para remolque
4. Selecciona diagnosis Interface Bus
5. Seguir las instrucciones

En vehículos noc sistemas de asistencia

6. Ejecutar adaptación de acoplamiento para remolque a suster de asistencia
7. Seguir las instrucciones
8. Diagnosis
9. Leer memoria de averias y borrarla si es necesario
10. Listo

NL

De activering van de aanhangerfuncties moet als volgt worden uitgevoerd:

1. Voertuigselectie
2. Ga naar Diagnose - Codering
3. Aanhangwagenkoppeling deactiveren/activeren
4. Diagnose interface bus selecteren
5. Volg instructie op

Bij voertuigen met assistentiesystemen

6. „Aanhangwagenkoppeling aanpassen aan assistentiesystem“ uitvoeren
7. Volg instructie op
8. Diagnose
9. Foutcodegeheugen uitlezen en indien nodig wissen
10. Gereed

Status LED für Eigendiagnose

Status LED for self-diagnosis

Operation support

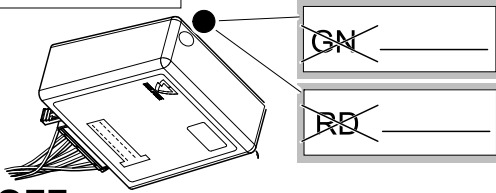
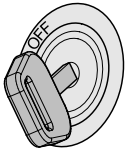

No CAN-Data =



Standby / Sleepmode

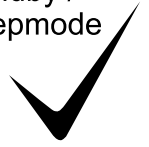

Ignition OFF

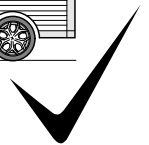
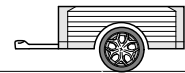
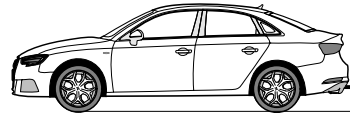
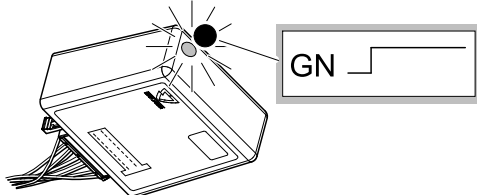

Ignition ON

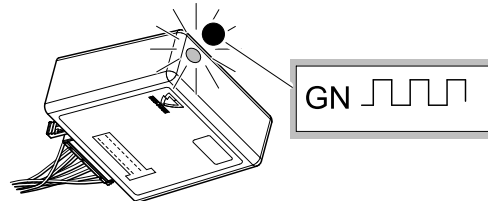

Ignition ON

Failure support

CAN-Data Wire



1x max. 5 min.

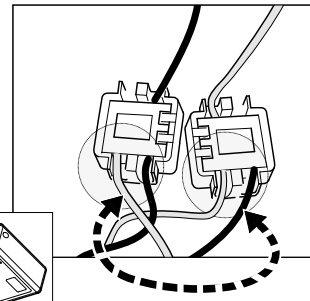
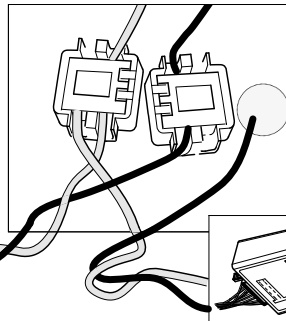
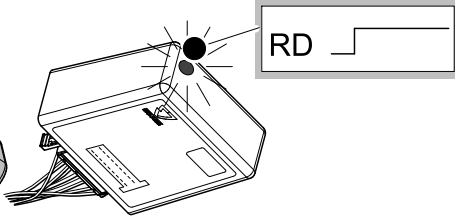

Ignition ON

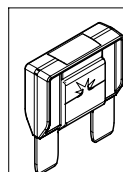
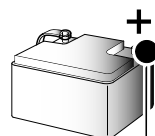
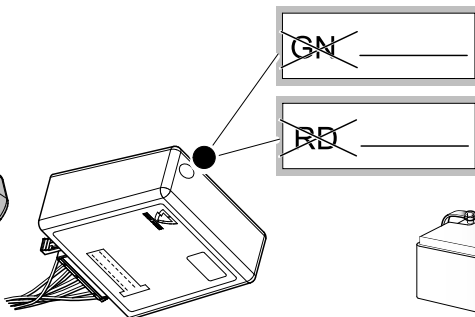
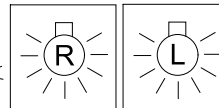

PIN 17 oder / or



PIN 1

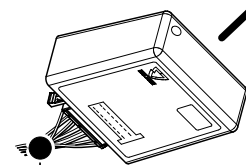

Ignition ON



<p>D Änderungen bezüglich Konstruktion, Ausstattung Farbe sowie Irrtum vorbehalten. Angaben und Abbildungen unverbindlich</p>	<p>PL Zastrzega się prawo do zmian dot. konstrukcji, wykończenia, kolorystyki oraz pomyłek. Dane i ilustracje niewiążące.</p>
<p>GB Subject to change in terms of construction, equipment and colour, and may contain errors. The information and illustrations are non-binding.</p>	<p>TR Tasarım, donanım ve renk bakımından değişiklik yapma hakkı ve hata ve eksiklik mahfuzdur. Veriler ve resimler bağlayıcı değildir.</p>
<p>F Sous réserve de modifications de la construction, de l'équipement, de la couleur et sous réserve d'erreurs. Les indications et les illustrations sont sans engagement.</p>	<p>H A szerkezet, a kivitelt és a szín változtatása, valamint a változások joga fenntartva. Az adatok és az ábrák nem kötelező érvényűek.</p>
<p>NL Wijzigingen met betrekking tot constructie, uitvoering en kleur evenals vergissingen voorbehouden. Gegevens en afbeeldingen zijn niet bindend.</p>	<p>HR Pravo promjena u svezi konstrukcije, opreme, boje kao i zabune oridžavamo. Podaci i ilustracije su neobavezne.</p>
<p>DK Ændringer med hensyn til konstruktion, udstyr, farver samt fejl forbeholdes. Oplysninger og illustrationer er uforpligtende.</p>	<p>BUL Запазени права по отношение на конструкцията, обзавеждането, цвета и грешки. Данните и изображенията не са обвързващи.</p>
<p>N Endringer angående konstruksjon, utstyr, farge og feiltagelse forbeholdes. Oplysninger og illustrasjoner uforbindtlig.</p>	<p>RO Ne rezervăm dreptul unor modificări ale construcției, dotării, culorii și dreptul la erori Datele indicate și imaginile sunt orientative.</p>
<p>S Med reservation för ändringar vad det gäller konstruktion, utrustning, färg samt för misstag. Uppgifterna och bilderna är inte bindande.</p>	<p>RU Права на внесение изменений относительно конструкции, оснащения, окраски, а также на ошибки сохраняются. Данные и иллюстрации имеют примерный характер.</p>
<p>FIN Pidätämme oikeuden rakennetta, varustusta, väriä koskeviin sekä erehdyksestä johtuviin muutoksiin. Tiedot ja kuvat eivät ole sitovia.</p>	<p>LT Pasiliekaama konstrukcijos, įrangos bei reikmenų, spalvos pakeitimų ir klaidų teisė. Duomenys ir iliustracijos neįpareigojantys.</p>
<p>I Con riserva di modifiche relative a progettazione, dotazione, colore ed errori. Le indicazioni e figure sono fornite senza impegno.</p>	<p>LV Tiek paturētas tiesības uz konstrukcijas, iekārtu, krāsu izmaiņām, kā arī kļūdīšanās. Dati un attēli bez saistībām.</p>
<p>E Reservadas las modificaciones respecto a diseño, equipamiento, color, así como error. Indicaciones y figuras sin compromiso.</p>	<p>EST Konstruktsiooni, varustuse ja võervi osas muudatused ning eksimine lubatud. Andmed ja joonised on mittesiduvad.</p>
<p>P Reservamos o direito de alterações relativamente ao desenho, equipamento, cor, bem como de erro. Os dados e as gravuras não implicam compromisso da nossa parte.</p>	<p>SLO Zadržana pravica do sprememb glede konstrukcije, opreme, barve ter pomote. Podatki in slike so neobvezne.</p>
<p>GR Διατηρώνουμε κάθε επιφύλαξη ως προς αλλαγές σε σχέση με κατασκευή, εξοπλισμό, διαρρύθμιση, χρωματισμούς και λάθη παραδρομής.</p>	<p>SK Zmeny, ktoré sa týkajú konštrukcie, vybavenia, farby, ako aj omyly sú vyhradené. Údaje a zobrazenia sú nezáväzné.</p>
<p>CZ Změny, týkající se konstrukce, vybavení, barvy, jakož i omyly jsou vyhrazeny. Údaje a vyobrazení jsou nezávazné.</p>	