

NOTE:
 HEAT EXCHANGER INTERNALLY FREE FROM LOOSE MATERIAL.
 NITROGEN DRIED AND SUPPLIED WITH PLASTIC PLUGS.
 LEAK TEST AT 4bar
 BRACKETS MADE OF 2mm ALUZINK STEEL
 WEIGHT: 4.8kg

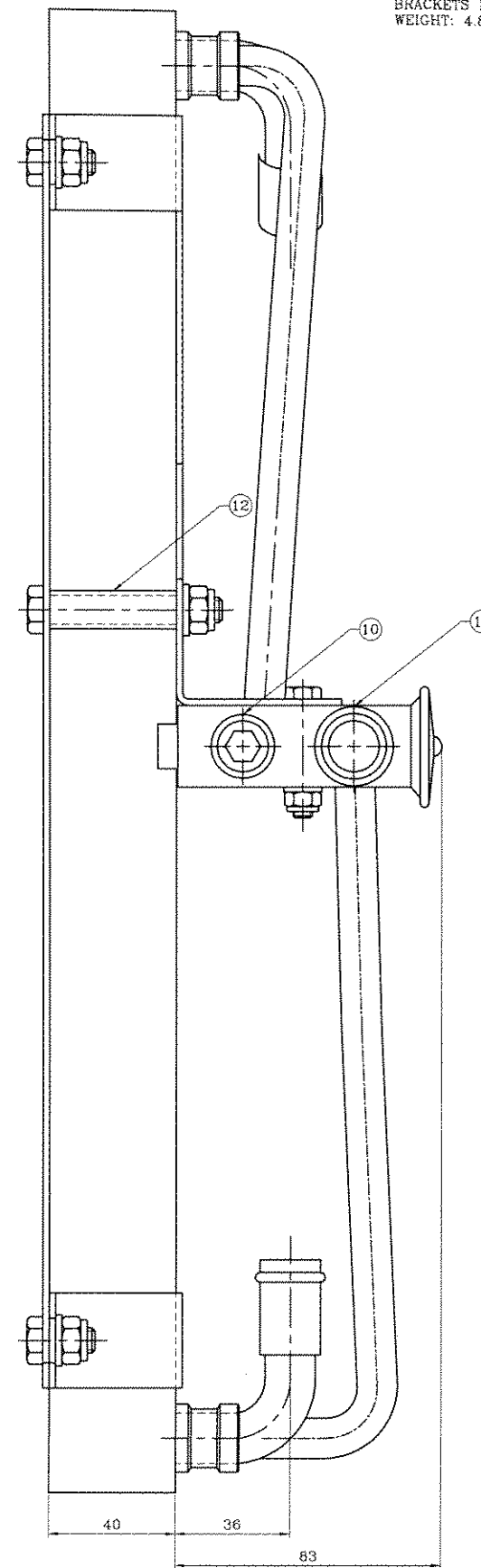
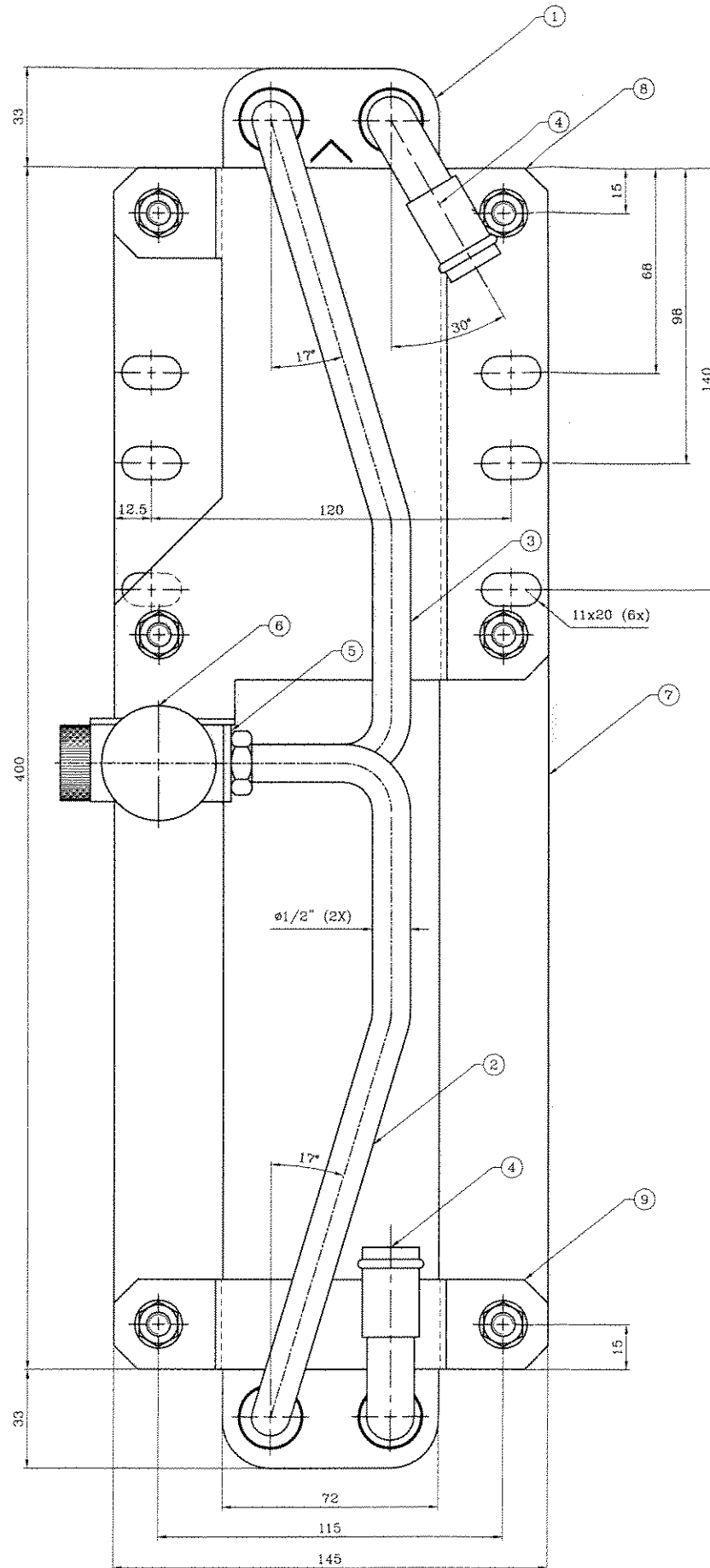
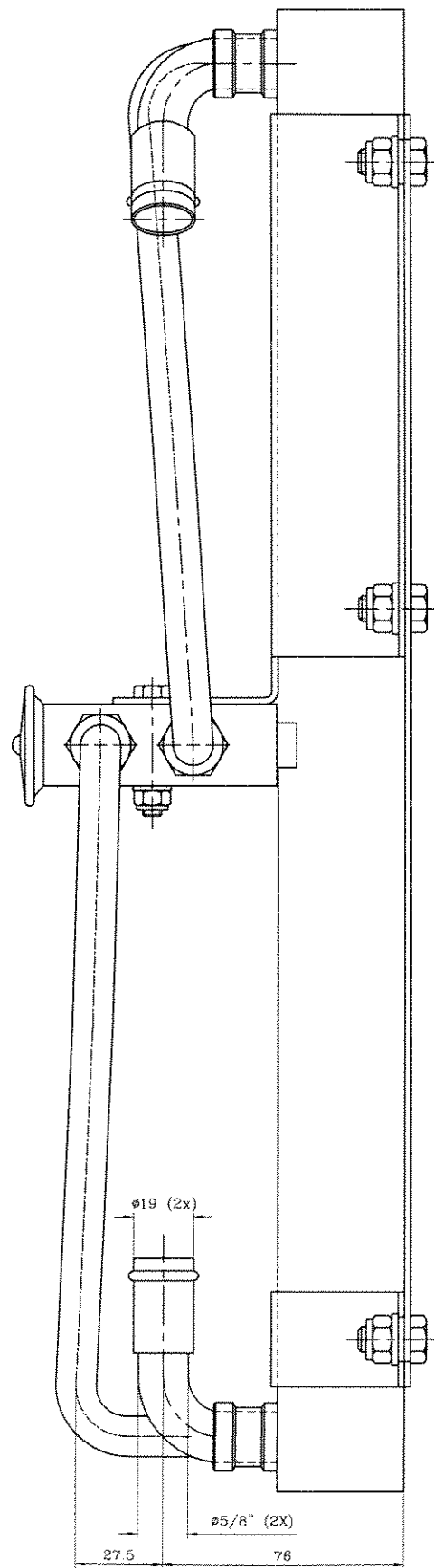

12	1	20.003.00336	DISTANS D=12,1=43mm
11	1	28-0670	PLUG EXPANSION VALVE #10
10	1	28-0669	PLUG EXPANSION VALVE #6
9	1	21.416.00.003	HOLDER
8	1	21.416.00.002	HOLDER
7	1	21.416.00.001	HOLDER
6	1	26-0190	EXPANSION VALVE
5	2	27-0602	O-RING
4	2	34-1914	CONNECTOR
3	1	34-1918	COPPER TUBE 1/2"
2	1	34-1919	COPPER TUBE 1/2"
1	1	20.003.00.004	HEAT EXCHANGER

3	REVISED AFTER DCR#211	010115	FE
1	CHANGED AFTER REVISION	990429	AH
SYM	DESCRIPTION	DATE	BY
	REVISION		

CHECK BY: _____ DATE: _____
 METRIC

SYM	PCS	PART NO.	DESCRIPTION	SCALE	BY
				NTS	CS
			21-0416		
			HEAT EXCHANGER	DATE: 010618	
				REV: _____	
				FIG: P1.21.416-4701	3