

040-0600 TriMount Push Button Handle



DESIGNED FOR:

- Off-highway vehicle applications that require a surface mounted exterior push button handle with 120mm or 163mm mounting pattern

FEATURES/BENEFITS:

- Retrofitable with most European push button handles
- Universal mounting is available in 3 different mounting configurations: 2 bolt 120mm, 3 bolt 120mm and 2 bolt 163mm mounting
- Frictionless push button seal
- Readily adaptable to a variety of door thickness with an adjustable bolt and nut
- Full gloved hand clearance
- 15.88mm (.625) button travel
- Easy to operate (ergonomics)



500 Bailey Avenue
P.O. Box 350
New Hampton, Iowa 50659
United States
Tel: 641-394-3188
Fax: 641-394-2392
1-800-447-0343
www.trimarkcorp.com



TriMark Europe, Ltd.

Cedar Court
Walker Road
Bardon Hill
Coalville LE67 1TU
United Kingdom
Tel: +44 (0)1530 512460
Fax: +44 (0)1530 512461
www.trimarkeu.com



040-0600 TriMount Push Button Handle

INSTALLATION:

- Installed with (2 or 3) M6 x1.0 bolts (not included)
- Mounts against glass with only 2 holes (see recommended hole pattern on last page)
- Recommended mounting fastener torque to be 5.6-6.7 N-m (50-59 lbf-in)

MATERIAL:

- Handle: glass reinforced nylon
- Brass threaded inserts

USE WITH:

- Please refer to our website for related products that are compatible for use with this product

AVAILABLE:

- Can be keyed alike with most single and reversible key systems or non-locking configurations
- Locked rigid or free-floating versions
- With bezels or gasket sets to facilitate mounting and provide resistance to water and dirt infiltration (sold separately)

Individual part dimensions are for reference only. Refer to individual part drawings for complete dimensions, specifications, and installation procedures. Engineering assistance and application drawings are available.

Design Patent No. D461,391

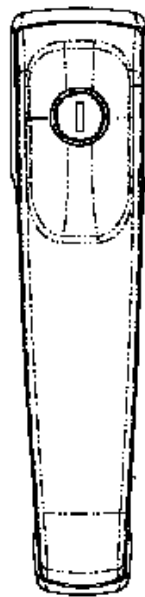
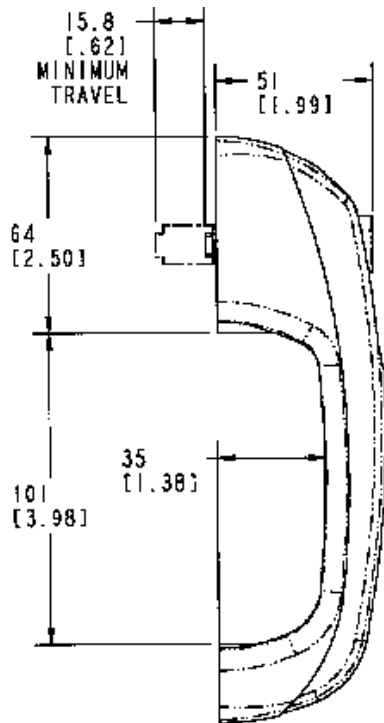

Gaskets



Bezels



ADJUSTABLE BOLT, NUT AND PLASTIC ADJ. END

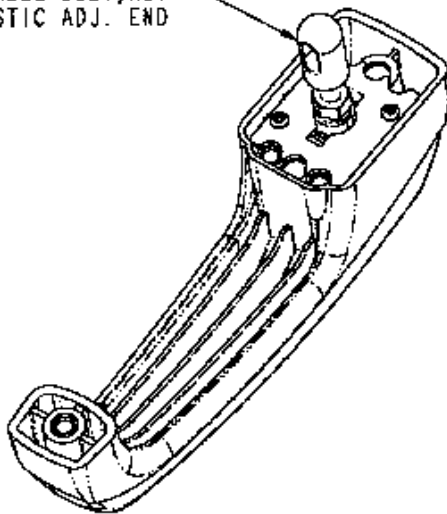

ROTATING CAM

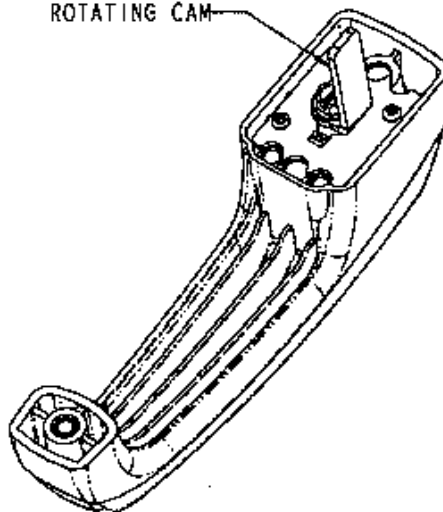

For more information visit
www.trimarkcorp.com