

030-1125

Two Point Paddle Handle

**DESIGNED FOR:**

- Cross bed tool boxes
- Truck topper and lift gate doors
- Most storage, compartment, and access doors with single or two point latch system

FEATURES/BENEFITS:

- Water resistant
- Sleek automotive styling
- Paddle is rigid when locked
- Shuttered key cylinder
- Keying security
- Flush mount -- contoured surface
- Corrosion resistant
- Slam action -- hook operates independent of paddle

www.trimarkcorp.com**TriMark Corporation**

500 Bailey Avenue
P.O. Box 350
New Hampton, Iowa 50659
United States
Tel: 641-394-3188
Fax: 641-394-2392
1-800-447-0343
www.trimarkcorp.com

TriMark Europe

Cedar Court
Walker Road
Bardon Hill
Coalville LE67 1TU
United Kingdom
Tel: +44(0)1530 512460
Fax: +44(0)1530 512461
www.trimarkeu.com

AVAILABLE:

- Non-locking or locking with shuttered key way
- Keyed alike or keyed random. 50 key codes - TM901-TM950
- Slam action version
- With rod collars

MATERIAL:

- Housing and paddle: die cast zinc alloy
- All steel parts (axles, pivot arm, pivot plate, lock cam): cold rolled steel with zinc plate yellow chromate for corrosion resistance

FINISH:

- Black powder coated

CAUTION: Product does not meet the locking requirements for FMVSS 206.

INSTALLATION:

- Supplied with gasket already applied under recess in housing flange for simple, clean installation
- Blind mounting with (1) #10-24 UNC mounting fastener
- Optional mounting brackets and hook designs (please inquire)

Individual part dimensions are for reference only. Refer to individual part drawings for complete dimensions, specifications, and installation procedures. Engineering assistance and application drawings are available.

Rod collars are not intended or recommended for use in applications that require FMVSS 206 compliance or applications that have heavy or extreme Striker Bolt Loads (> 25 lbs./ 11 kg.) and/or high to extreme usage (> 100,000 door cycles/life).

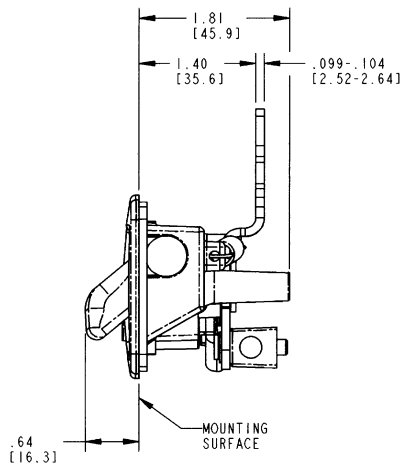
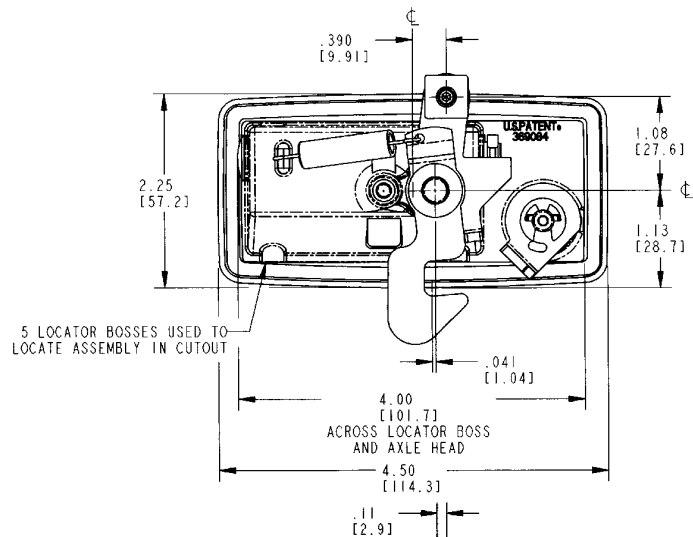

For more information visit www.trimarkcorp.com

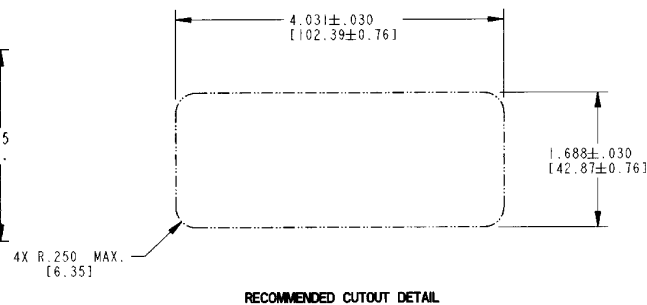
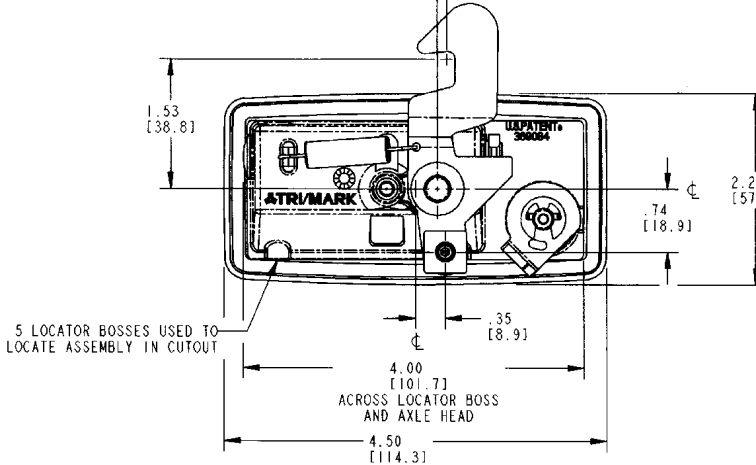

RECOMMENDED CUTOUT DETAIL